



INTERNATIONAL APPLICATION PUBLISHED UNDER THE PATENT COOPERATION TREATY (PCT)

| | | |
|--|------------------|---|
| <p>(51) International Patent Classification ⁵ : A62B 18/02, 18/08</p> | <p>A1</p> | <p>(11) International Publication Number: WO 92/00120 (43) International Publication Date: 9 January 1992 (09.01.92)</p> |
| <p>(21) International Application Number: PCT/GB91/01034 (22) International Filing Date: 26 June 1991 (26.06.91) (30) Priority data: 9014212.6 26 June 1990 (26.06.90) GB 9111070.0 22 May 1991 (22.05.91) GB (71) Applicant (for all designated States except US): CAM LOCK (UK) LTD. [GB/GB]; 70 Hawley Lane, Farnborough, Hants GU14 8EH (GB). (72) Inventors; and (75) Inventors/Applicants (for US only) : GRIFFITHS, Joseph, Anthony [GB/GB]; Midtrees, Petworth Road, Haslemere, Surrey GU27 3BD (GB). SMEATON, Donald, McIntyre [GB/GB]; 11 Devonshire Place, Brighton, Sussex BN2 1QA (GB).</p> | | <p>(74) Agents: WOODWARD, John, Calvin et al.; Venner, Shipley & Co., 368 City Road, London EC1V 2QA (GB). (81) Designated States: AT (European patent), BE (European patent), CA, CH (European patent), DE (European patent), DK (European patent), ES (European patent), FR (European patent), GB (European patent), GR (European patent), IT (European patent), LU (European patent), NL (European patent), SE (European patent), US. Published <i>With international search report. Before the expiration of the time limit for amending the claims and to be republished in the event of the receipt of amendments.</i></p> |

(54) Title: IMPROVED BREATHING EQUIPMENT FOR AIRCREW**(57) Abstract**

A facemask incorporating breathing equipment for use with a flying helmet (2) comprises a rigid outer shell (4) in which a flexible face-piece (3) is housed whose periphery makes an airtight seal with the pilot's face (1). The face-piece (3) includes an inhalatory valve (11) and an expiratory valve (9) and the rigid shell (4) is attached to the helmet (2) by a harness (5) which keeps the shell (4) at a fixed distance from the helmet (2). Inflatable means (15, 20) are provided between the shell (4) which are inflated to press the periphery (14) of the face-piece towards the pilot's face when the pressure of breathable gas supplied to the interior of the mask and to said inflatable means increases above that required for normal breathing. Alternatively, the face-piece (3) can include extendable means in the form of a re-entrant section (30, 34, 35) or bellows section (36) which extends in a direction towards the pilot's face when the pressure of the breathable gas supplied to the interior of the face-piece (3) increases above that required for normal breathing.

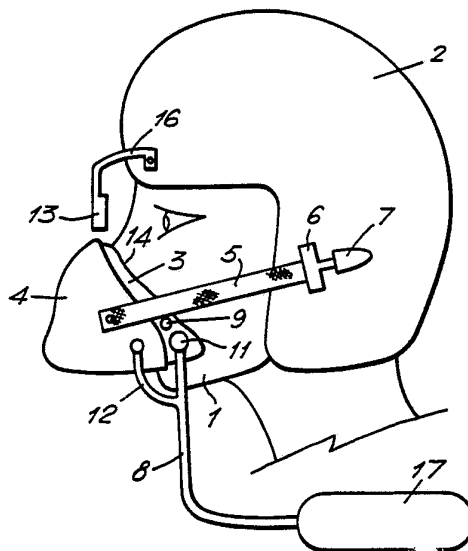

FOR THE PURPOSES OF INFORMATION ONLY

Codes used to identify States party to the PCT on the front pages of pamphlets publishing international applications under the PCT.

| | | | | | |
|----|--------------------------|----|--|----|--------------------------|
| AT | Austria | ES | Spain | MG | Madagascar |
| AU | Australia | FI | Finland | ML | Mali |
| BB | Barbados | FR | France | MN | Mongolia |
| BE | Belgium | GA | Gabon | MR | Mauritania |
| BF | Burkina Faso | GB | United Kingdom | MW | Malawi |
| BG | Bulgaria | GN | Guinea | NL | Netherlands |
| BJ | Benin | GR | Greece | NO | Norway |
| BR | Brazil | HU | Hungary | PL | Poland |
| CA | Canada | IT | Italy | RO | Romania |
| CF | Central African Republic | JP | Japan | SD | Sudan |
| CG | Congo | KP | Democratic People's Republic of Korea | SE | Sweden |
| CH | Switzerland | KR | Republic of Korea | SN | Senegal |
| CI | Côte d'Ivoire | LI | Liechtenstein | SU | Soviet Union |
| CM | Cameroon | LK | Sri Lanka | TD | Chad |
| CS | Czechoslovakia | LU | Luxembourg | TG | Togo |
| DE | Germany | MC | Monaco | US | United States of America |
| DK | Denmark | | | | |

- 1 -

IMPROVED BREATHING EQUIPMENT FOR AIRCREW

DESCRIPTION

5 This invention relates to breathing equipment for
aircrew.

The normal breathing equipment for aircrew comprises
a flexible face mask having an inspiratory valve
10 supplied with oxygen or some other breathable gas and
an expiratory valve to allow the pilot to expel the
air from the mask on exhalation. The face mask is
attached to the pilot's helmet by means of a harness
incorporating a releasable fitting.

15

In fighter aircraft, it is necessary that the face
mask makes a proper seal with the pilot's face at all
times. Under normal flying conditions, this is not a
20 problem as the pilot adjusts the harness tension so
that it makes the necessary seal and is also
comfortable to wear. The supply of the breathable
mixture through the mask is controlled by a breathing

SUBSTITUTE SHEET

- 2 -

gas regulator which is responsive to the G-forces that it is subject to. In other words, when the G-force increases, the pressure of the gas supply is correspondingly increased and vice versa. Thus, changes in the G-forces applied to the regulator controlling the breathable gas supply result in automatic changes in pressure in the interior of the mask. It will be appreciated that unless some suitable means are provided to improve the seal between the mask and the pilot's face, any increase in pressure within the mask cavity will cause the mask seal to leak to atmosphere so the pilot will not receive the pressure of breathable gas he requires and could black-out. This condition will be critical, particularly in a combat situation.

One known way of overcoming this problem has been to provide an over-centre toggle in the harness assembly attaching the mask to the helmet. The over-centre toggle is in its non-tensioned position for normal flight but, when the pilot wants to make a tight turn, he moves the toggle into its tensioned position before he makes the turn thereby increasing the

SUBSTITUTE SHEET

- 3 -

tension on the face mask and improving its seal on his face. After the turn is completed, the pilot then releases the toggle. Indeed he has to do this because the pressure exerted on his face when the toggle is engaged is so great that it is very uncomfortable. The main problem with this arrangement is that the pilot has to remember to engage the toggle before he makes a turn (possibly difficult in a combat situation). Furthermore, he must release the toggle after the turn as the pressure on his face is too high to be comfortable for normal flying.

In another known solution, the problem of the pilot having to normally tension the toggle on the facemask each time he makes a turn is overcome by connecting the facemask inlet hose, supplied by the regulator to a bladder situated in the pilot's helmet between the back of his head and the inside of the helmet. With this arrangement, when the regulator automatically increases the breathable gas pressure to the facemask, the bladder is inflated and pushes the rear of the helmet away from the rear of the pilot's head.

SUBSTITUTE SHEET

- 4 -

Because the breathing mask is attached to the helmet
by means of the harness arrangement which is
inextensible, the breathing mask is drawn towards the
pilot's face thereby increasing its sealing
5 capability and coping with the increased pressure of
the gas supplied to the interior of the mask. After
the turn has been completed, the regulator
automatically reduces the gas supply pressure so the
bladder is correspondingly deflated and the increased
10 mask pressure on the pilot's face is reduced
accordingly. Thus, it will be appreciated that with
this system, automatic adjustment of the pressure
exerted by the mask on the pilot's face is achieved,
this pressure being dependant on the G-forces
15 generated by the aeroplane during flight which are
sensed by the regulator controlling the breathable
gas supply.

Whilst it might appear that a helmet incorporating a
20 bladder provides an excellent solution to the problem
of continually adjusting the pressure of the mask on
the pilot's face, there is a serious problem with
this arrangement because fighter pilots in the future

SUBSTITUTE SHEET

- 5 -

will have avionic systems attached to their helmets incorporating an armament sight which the pilot has to look through in order to direct his fire power on the target. This sight normally comprises an arm or
5 the like attached to the helmet and extending forwardly therefrom into the pilot's line of vision. Thus, everytime the pilot's helmet moves, the sight will also move. It will be appreciated therefore that such a sighting system cannot be satisfactorily
10 used with a breathing system which necessitates the helmet to move to improve the sealing of the facemask on the pilot's face as the sight will not work accurately. Thus, avionic systems cannot be used effectively with a helmet of this type.

15

It is therefore an object of the present invention to provide an improved facemask for use with an aircrew flying helmet which overcomes or substantially reduces the problems of the prior art by causing the
20 face-piece to which the breathable gas is supplied rather than the pilot's helmet to be moved towards the pilot's face and thus increase the seal therewith when the pressure of the breathable gas supplied to

- 6 -

the interior of the mask increases above that
required for normal breathing and vice versa. By
keeping the pilot's helmet stationary at all times
and dynamically moving the facemask in relation
5 thereto, avionic systems can be attached to the
helmet which will work satisfactorily.

According to the invention, there is provided a
facemask incorporating breathing equipment for use
10 with an aircrew flying helmet comprising a rigid
outer shell in which a flexible face-piece is
received whose periphery is adapted to make a seal
with the pilot's face, the face-piece incorporating
an inspiratory and expiratory valve and the outer
15 shell having means for attaching it at a fixed
distance from the helmet, the face-piece further
including extendable means automatically operable to
press the periphery of the face-piece towards the
pilot's face to improve the seal therewith when gas
20 at a pressure above that required for normal
breathing is supplied to the facemask and the
extendable means reconfigure as a result thereof.

- 7 -

The extendable means can comprise inflatable means such as an inflatable bladder located between the shell and the face-piece which is operable to move the whole of the face-piece on inflation, away from the shell and towards the pilot's face to improve the seal therewith at the periphery thereof and vice versa.

Alternatively, the inflatable means can take the form of an inflatable chamber provided in the periphery of the flexible face-piece where it makes its seal with the pilot's face.

In one preferred embodiment, the periphery of the face-piece is substantially C-shaped in cross section to provide an edge sealing lip which faces towards the rigid outer shell, the inflatable chamber being provided in said C-shaped periphery.

In another embodiment, the inflatable means comprises a chamber provided in the face-piece between the front and the edge periphery thereof, said chamber on inflation being reconfigured as a result of which

- 8 -

the periphery is moved towards the pilot's face and vice versa.

In the aforementioned arrangements, the inflatable means are inflated by gas supplied from the breathable gas supply connected thereto. However, the invention also provides arrangements where the extendable means are not actually inflated by the breathable gas but instead the face-piece incorporates an extendable section in its wall which reconfigures and extends when the breathable gas is supplied to the interior of the face-piece with the result that the edge region of the face-piece is pressed against the pilot's face with an increased pressure.

The extendable means can comprise a re-entrant section in the wall of the face-piece or it can take the form of a bellows section or a convoluted rolling section whose wall thickness is less than that of the remainder of the face-piece wall. In this latter embodiment, the convoluted rolling section is preferably generally S-shaped in cross-section.

- 9 -

For the extendable means to work properly and move the periphery of the face-piece into better contact with the pilot's face, radial or lateral movement or expansion of the face-piece wall needs to be restricted. It is therefore preferably wholly contained within the rigid outer shell. It could however work satisfactorily if it was only partially within said shell.

When the improved breathing mask of the present invention is attached to a pilot's flying helmet, for instance using a known harness arrangement, the rigid outer shell will not be movable in a direction away from the front of the helmet. As the extendable means are actuated by the breathable gas supply controlled by a known regulator, they will be inflated and deflated or extended or contracted dependent on the increase or decrease in the breathable gas supply. Thus an increase in pressure within the face piece can only result in it being pushed further towards the pilot's face to increase the pressure thereon and thus the seal. If however there is a decrease in the gas supply, the mask will

- 10 -

move away from the pilot's face by a corresponding amount and the pressure thereon will be reduced.

5 It will be appreciated from the foregoing that the helmet does not move in relation to the pilot's head during any of the movements of the face-piece so avionic equipment can be mounted on the helmet and will work perfectly satisfactorily.

10 Preferred embodiments of the invention will now be described, by way of example only, with reference to the accompanying diagrammatic drawings in which:

15 Figure 1 is a side view of one form of facemask of the present invention illustrated in use with an aircrew helmet and a breathable gas supply;

20 Figure 2 is a cross-section through the facemask shown in Figure 1;

- 11 -

Figure 3 is a perspective view of another
form of facemask of the invention;

5

Figure 4 is a plan view in cross-section
of the facemask shown in Figure 3 with some
parts omitted for ease of illustration;

10

Figure 5 is a scrap view of a part of the
facemask shown in Figure 4;

15

Figure 6 is a schematic view of another
type of face-piece for use with a facemask
of the present invention;

20

Figure 7 is a side view of an alternative
facemask of the present invention
illustrated in use with an aircrew helmet
and a breathable gas supply;

Figure 8 is a schematic view, on an enlarged
scale, of part of the facemask shown in

- 12 -

Figure 7 in its normal condition and extended conditions; and,

5 Figures 9-12 illustrate schematically various alternative flexible face-pieces in their normal and extended conditions.

Referring now to the drawings, Figure 1 shows a pilot
10 1 wearing a rigid protective helmet 2. A flexible breathing face-piece 3, usually made of natural or synthetic rubber, surrounds the pilot's nose and mouth and is mounted in a rigid plastic shell 4 attached to the helmet 2 by means of a harness
15 arrangement 5 having a fitting 6 at one end to releasably attach it to a fitting part 7 mounted on the helmet. The harness 5 includes adjustable means (not shown) so that its length can readily be adjusted to ensure that the face-piece 3 rests
20 comfortably on the pilot's face with its edge lip 14 making a proper seal with the area of the pilot's face surrounding his nose and mouth. An avionic armament sight 13 is mounted on an arm 16 attached to

SUBSTITUTE SHEET

- 13 -

the helmet 2, and protrudes forwardly therefrom into the pilot's line of vision as illustrated.

Breathable gas such as oxygen is supplied to the interior of the face-piece 3 from a pressurised gas supply 17 connected to an inlet 11 by means of a hose 8 and controlled by a regulator (not shown). A secondary inlet hose 12 connects the gas inlet hose 8 to an inflatable bladder 15 (see Figure 2) located between the rigid shell 4 and the face-piece 3. An exhalatory valve 9 is also provided in the face-piece 3.

The operation of the illustrated arrangement is as follows:

In normal flight where no G-forces are exerted on the aircraft, breathable gas is supplied from the pressurised supply 17 via inlet hose 8 to the interior of the face-piece 3 fitted over the pilot's nose and mouth. As soon as the pilot makes a turn, this will generate G-forces which will affect the regulator (not shown) which in turn will increase the

- 14 -

pressure of the gas supplied from the source 17 to
the face-piece 3. The bladder 15 will therefore be
correspondingly inflated by the increased gas
pressure supplied to its interior via the secondary
5 supply hose 12. As the rigid shell 4 cannot move
relative to the helmet 2 because its position in
relation thereto is controlled by the harness 5 which
is of fixed length, inflation of the bladder 15 will
push the face-piece 3 the helmet 2 as indicated by
10 the arrows in Figure 2. This movement effectively
increases the seal of the face-piece 3 on the pilot's
face. Reductions in the gas supply pressure cause
the bladder 15 to deflate accordingly and thus to
reduce the pressure of the
15 face-piece 3 on the pilot's face.

It will be appreciated that during flight, the
aeroplane will be making many turns and the G-forces
generated will therefore vary considerably. The
20 regulator (not shown) which controls the gas supply
from the source 17 in combination with the inflation
and deflation of the bladder 15 therefore ensures

SUBSTITUTE SHEET

- 15 -

that the face-piece 3 can be kept in contact with the pilot's face at the required pressure.

5 Since it is the face-piece 3 which is moving relative to the pilot's face to increase or decrease its seal therewith, the helmet 2 remains stationary at all times so the avionics sight 13 can be attached to it and will work perfectly satisfactory regardless of the G-forces to which the pilot or the aircraft is
10 being subjected.

Referring now to the arrangement shown in Figures 3-5, it can be seen that the facemask comprises a rigid shell 4 in which a flexible face-piece 3 is
15 received which is provided with an inlet 8 supplied with a breathable gas mixture, the supply pressure of which is controlled by a first regulator (not shown) in the manner already described.

20 The periphery of the face-piece 3 (see Figure 4) is shaped to include a lip seal 14 which presses against the pilot's face 1 to make a seal therewith. The interior of the lip seal 14 is moulded so as to be

- 16 -

hollow and provide pneumatic chamber 20 extending along the length thereof. The interior of the chamber 20 is connected by pipe 22 to a separate gas supply (not shown) controlled by a second regulator
5 (not shown) whereby gas from said separate gas supply is fed to the interior of the pneumatic chamber 20 at a pressure slightly higher than that supplied via inlet 8 to the interior 21 of the face-piece 3.

10 The operation of the illustrated system is as follows:

Gas is supplied to the interior 21 of the face-piece 3 through the gas inlet 8 controlled by the first
15 regulator (not shown) in the usual way. However, as the G-forces increase and decrease during flight, the second regulator controls the supply of gas from the separate gas supply to the interior of the pneumatic chamber 20 via inlet 22 so that it is fed thereto at
20 a pressure above that supplied to the interior 21 of the face-piece 3 so the chamber 20 is inflated and the edge seal 14 moves to the alternative position 14' indicated in Figure 5. It can be seen therefore

- 17 -

that the pressure applied by the edge seal 14 on the pilot's face increases automatically if the gas supply thereto increases under the control of the second regulator (not shown) and vice versa. This is
5 because the only direction the edge seal 14 can move on inflation of the chamber 20 is towards the pilot's face as the shell 4 is fixed and cannot move relative to the helmet 2 because of the restraint therein by the harness 5.

10

In the arrangement shown in Figure 6, face-piece 3 incorporates a chamber 27 which is supplied via inlet 28 with a separate gas supply (not shown) to that supplied to the interior of the face-piece 3. The
15 gas supply to the chamber 27 also has to be at a pressure higher than that supplied to the interior of the face-piece 3 otherwise it will not be inflated and assume the illustrated configuration 27a in which the edge seal 14 is moved in the direction of the
20 arrows towards the pilot's face.

SUBSTITUTE SHEET

- 18 -

Referring now to Figures 7-12 of the drawings, as with the previously described embodiments there is shown a pilot 1 wearing a rigid protective helmet 2. A flexible breathing face-piece 3, usually made of natural or synthetic rubber, surrounds the pilot's nose and mouth and is mounted in a rigid plastic shell 4 attached to the helmet 2 by means of harness arrangement 5 having fitting 6 at one end to releasably attach it to fitting part 7 mounted on he
5 helmet. The harness 5 includes adjustable means (not shown) so that its length can be readily altered to ensure that the face-piece 3 rests comfortably on the pilot's face with its edge lip 33 making a proper seal with the area of the pilot's face surrounding
10 his nose and mouth. An avionic armament sight 13 is mounted on arm 16 attached to the helmet 2 to protrude forwardly therefrom into the line of vision as illustrated.

20 Breathing gas such as oxygen is supplied to the interior of the face-piece 3 from an oxygen regulator (not shown) connected thereto by means of a hose 8.

SUBSTITUTE SHEET

- 19 -

An expiratory valve (not shown) is also provided in the face-piece 3.

As can be seen more clearly in Figure 8, the wall of the face-piece 3 includes extendable means 30 which are housed within the rigid shell 4. The purpose of the extendable means 30 is to enable the edge seal 33 to move in a direction generally parallel to the wall of the rigid shell 4 when the pressure supplied to the interior of the face-piece 3 is increased as a result of the regulator (not shown) being activated when the aircraft makes a turn. When the pressure supplied to the interior of the face-piece 3 increases, its wall expands to cope with the increased pressure. As the wall cannot move radially outwardly because it is contained within the rigid shell 4, it can only move in a direction generally towards the pilot's face in the direction of the arrows and thereby improves its seal therewith.

20

Figures 9-12 illustrate several different types of flexible face-piece 3 which incorporate alternative forms of extendable means. In each of these

- 20 -

embodiments it is the breathable gas supply to the interior of the face piece 3 at its constantly changing pressure which causes the extendable means to extend/expand or contract.

5

In the arrangement shown in Figure 9, the wall of the face-piece 3 includes a re-entrant section 34 which opens up or extends on pressurisation of the interior of the face-piece 3 to reconfigure into the profile 10 34a whereby the edge region 33 shown in dotted line moves in the direction of the arrows into the position shown in full line.

The face-piece 3 shown in Figure 10 is similar to 15 that shown in Figure 9 except that the re-entrant sections 35 include a generally circular portion in cross-section and reconfigure on inflation of the interior of the face-piece 3 into the profile 35a whereby the edge region 33 shown in dotted line moves 20 in the direction of the arrows into the position shown in full line.

SUBSTITUTE SHEET

- 21 -

Figure 11 shows yet another face-piece configuration in which it incorporates a bellows section 36 which extends into configuration 36a and causes the edge region 33 to move towards the pilot's face.

5

In the arrangement shown in Figure 12, the face-piece 3 is housed within the rigid shell 4 as has already been described. The face-piece 3 is manufactured with a convoluted rolling section 41 situated behind and adjacent the edge seal 33 and accommodated in an enlarged section 42 of the rigid shell 4.

10

As can be seen from the drawings, the thickness of the wall of the face-piece 3 in the region of the convoluted rolling section 41 is thinner than the remainder of the face-piece 3 thereby allowing it to be rolled back on itself into the S-shaped configuration illustrated.

15

In its normal state, the face-piece 3 is contained within the shell enlargement 42. However, when the pressure of the gas supply to the interior of the face-piece 3 is increased, the convoluted rolling

20

- 22 -

section 41 tends to unroll and the edge seal 33 is moved in the direction of the arrows thereby increasing the force applied by the edge seal 33 to the pilot's face thus preventing leakage.

5

It will be seen from the foregoing description that the invention provides a simple dynamic system which adjusts the pressure of the face-piece 3 on the pilot's face automatically in response to the regulator controlled breathable gas supply pressure. As it is the face-piece 3 which moves rather than the helmet 2 or the shell 4, avionic systems can be mounted on the helmet.

10

SUBSTITUTE SHEET

- 23 -

CLAIMS

1. A facemask incorporating breathing equipment for
5 use with an aircrew flying helmet comprising a rigid
outer shell in which a flexible face-piece is
received whose periphery is adapted to make a seal
with the pilot's face, the face-piece incorporating
an inspiratory and expiratory valve and the outer
10 shell having means for attaching it at a fixed
distance from the helmet, the face-piece further
including extendable means automatically operable to
press the periphery of the face-piece towards the
pilot's face to improve the seal therewith when gas
15 at a pressure above that required for normal
breathing is supplied to the facemask and the
extendable means reconfigure as a result thereof.

2. A facemask as claimed in claim 1 wherein said
20 extendable means comprises inflatable means located
between the shell and the mask.

SUBSTITUTE SHEET

- 24 -

3. A facemask as claimed in claim 2 wherein, the
inflatable means comprises a separate bladder located
between the shell and the front of the face-piece
which is operable to move the whole of the face-piece
5 , on inflation, away from the shell and towards the
pilot's face to improve the seal therewith at the
periphery of the mask and vice versa.

4. A facemask as claimed in claim 2 or claim 3
10 wherein, the inflatable means comprises an inflatable
chamber provided in the periphery of the flexible
face-piece where it makes its seal with the pilot's
face.

5. A facemask as claimed in claim 4 wherein the
15 periphery of the face-piece is substantially C-shaped
in cross-section to provide an edge sealing lip which
faces towards the rigid outer shell, the inflatable
chamber being provided in said C-shaped periphery.

20 6. A facemask as claimed in claim 2 wherein the
inflatable means comprises a chamber provided in the
face-piece between the front and the edge periphery

- 25 -

thereof, said chamber on inflation being reconfigured as a result of which the periphery is moved towards the pilot's face and vice versa.

5 7. A facemask as claimed in any one of claims 2-5 wherein the inflatable means are inflated by gas supplied from the breathable gas supply connected thereto.

10 8. A facemask as claimed in claim 1 wherein the extendable means comprises an extendable section in the wall of the face-piece located within the rigid outer shell.

15 9. A facemask as claimed in claim 8 wherein the extendable means comprises a re-entrant section in the wall of the face-piece.

20 10. A facemask as claimed in claim 8 wherein the extendable means comprises bellows section in the wall of the face-piece.

- 26 -

11. A facemask as claimed in claim 8 wherein the extendable section comprises a convoluted rolling section formed in the wall of the face-piece.
- 5 12. A facemask as claimed in claim 11 wherein the thickness of the wall of the convoluted rolling section is less than that of the remainder of the face-piece wall.
- 10 13. A facemask as claimed in claim 11 or claim 12 wherein the convoluted rolling section is generally S-shaped in cross section.
- 15 14. A facemask as claimed in any one of claims 8-13 wherein the extendable section is located wholly within the rigid outer shell.
- 20 15. A facemask as claimed in any one of claims 8-14 wherein the breathable gas supplied to the interior of the face-piece at said increased pressure causes the extendable means to reconfigure and move the periphery of the mask towards the pilot's face.

SUBSTITUTE SHEET

- 27 -

16. A facemask as claimed in any one of the preceding claims wherein the rigid shell is attached to the pilot's flying helmet by means of a harness which positions the rigid shell in a fixed position
5 relative to the flying helmet.

17. A breathing system for a pilot comprising a face mask, a regulator controlling a pressurised breathable gas supply thereto, the facemask
10 comprising a rigid outer shell in which a face-piece to cover the pilot's nose and mouth is located, the shell being connectable to a flying helmet by means which retain said shell at a fixed distance from the flying helmet, and extendable means automatically
15 operable when supplied with said breathable gas to move the periphery of the mask towards the pilot's face with an increased pressure to improve the seal therewith and vice versa.

20

SUBSTITUTE SHEET

1/5

FIG.1.

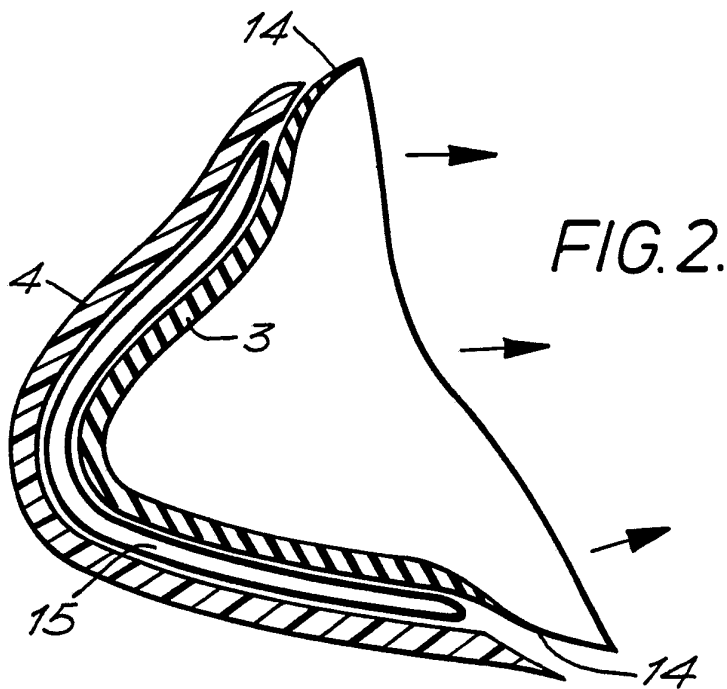
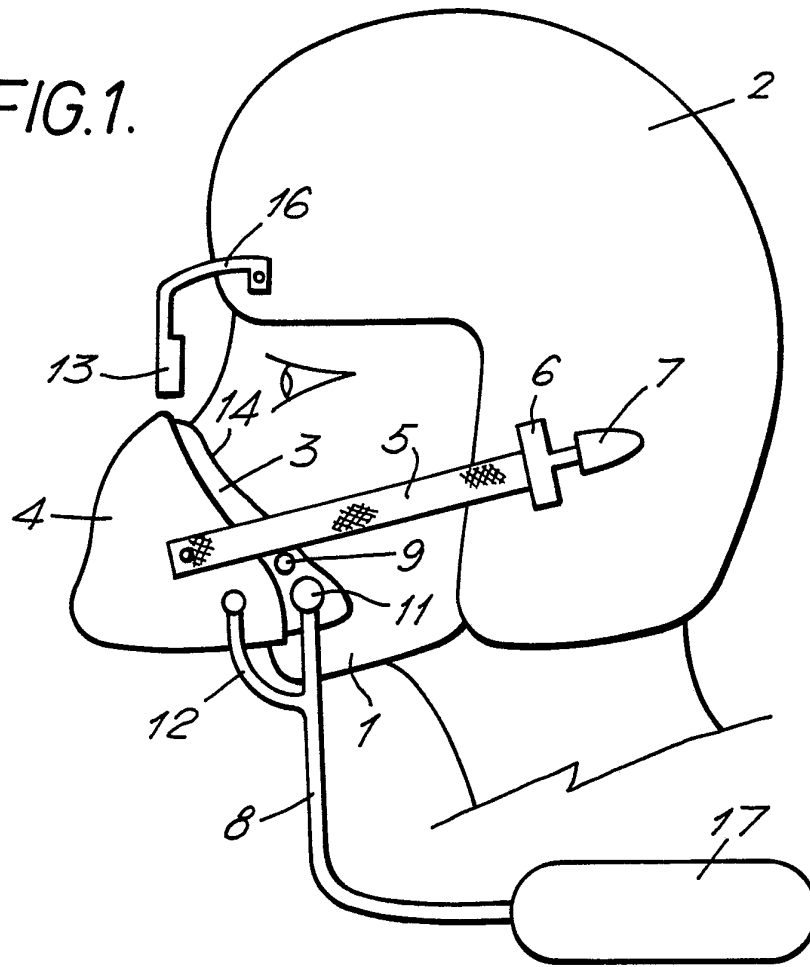

FIG.2.

FIG.3.

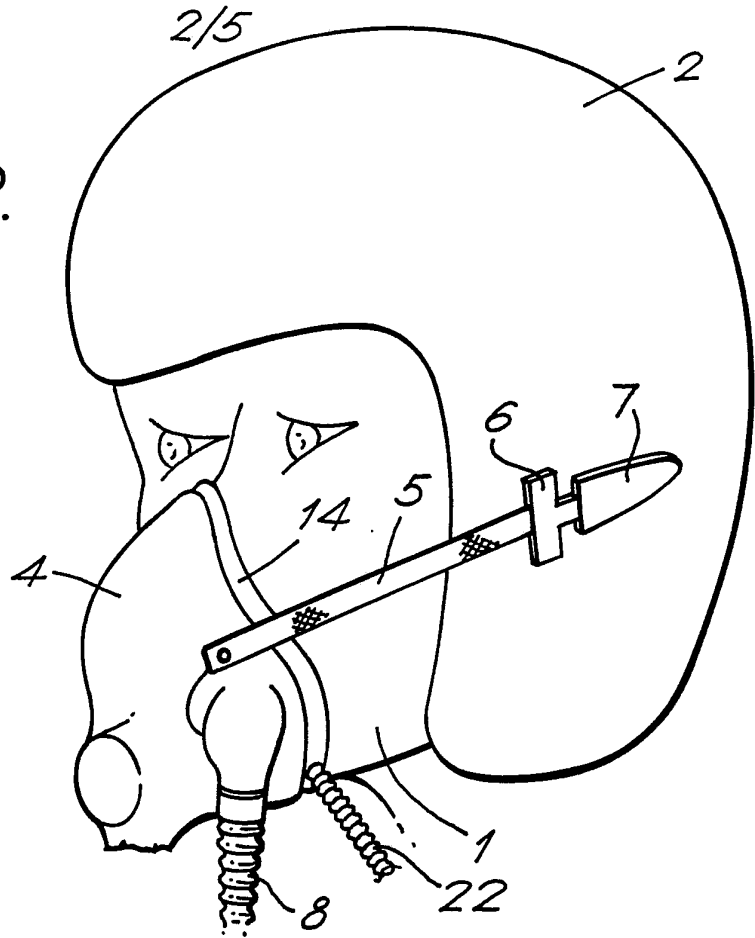

FIG.4.

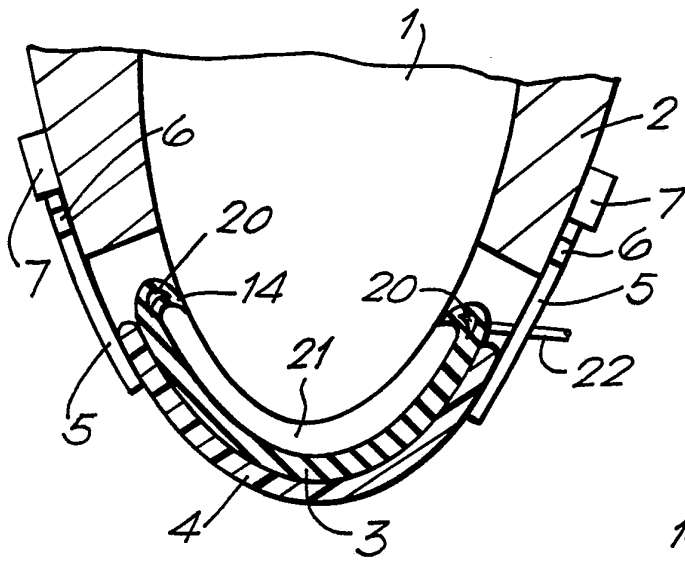

FIG.5.

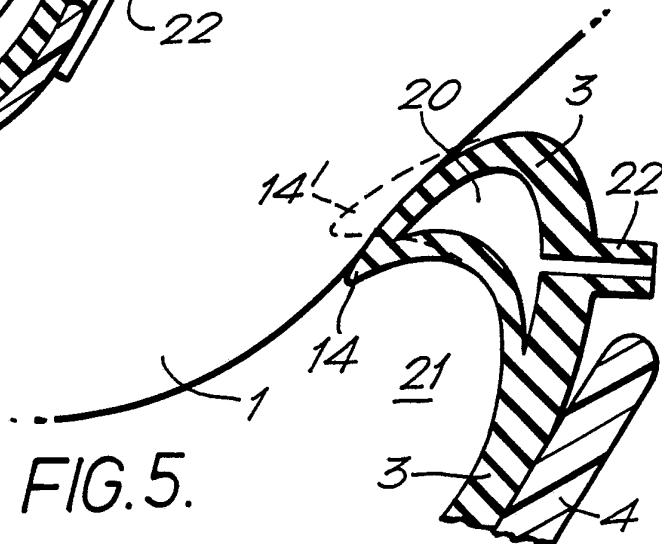

FIG. 6.

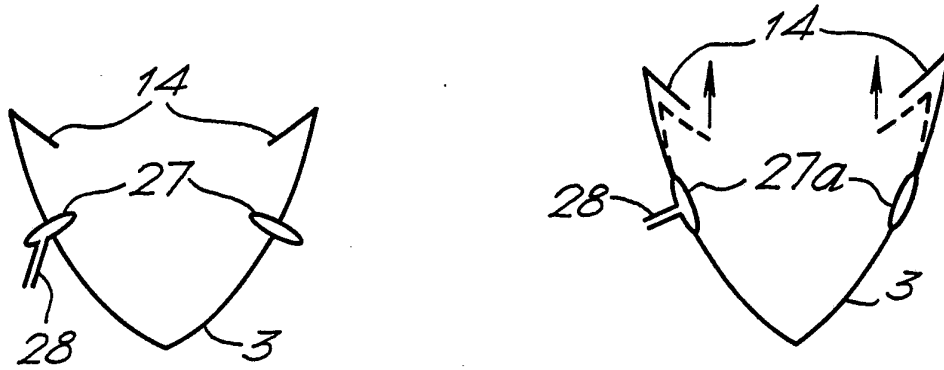
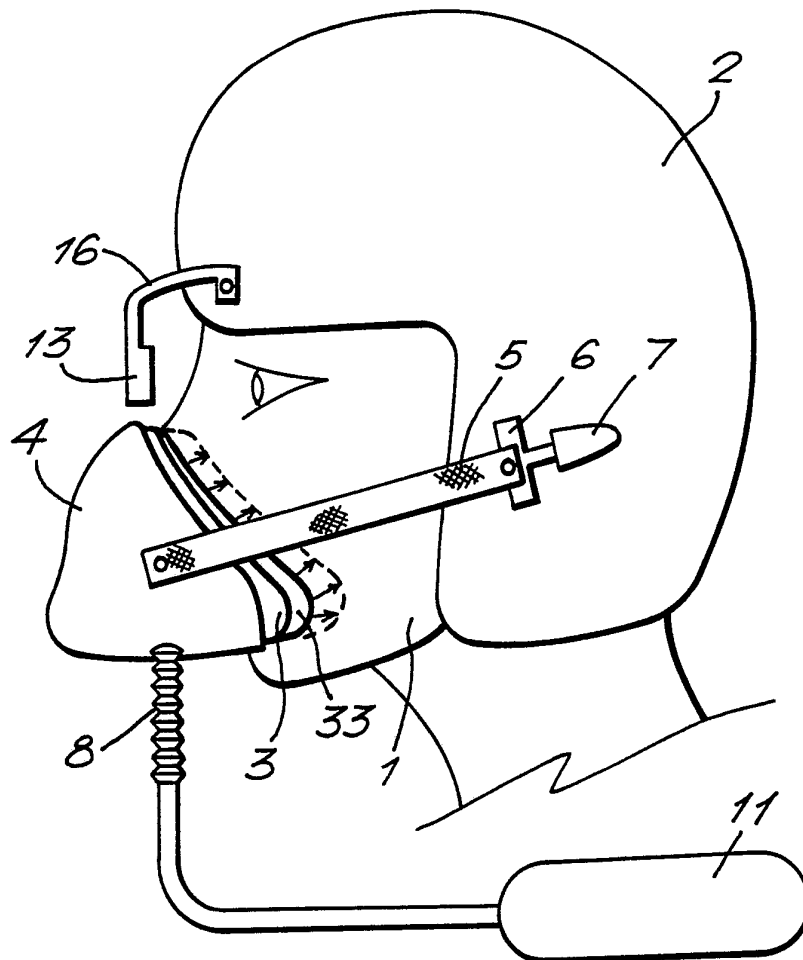

FIG. 7.



4/5

FIG. 8.

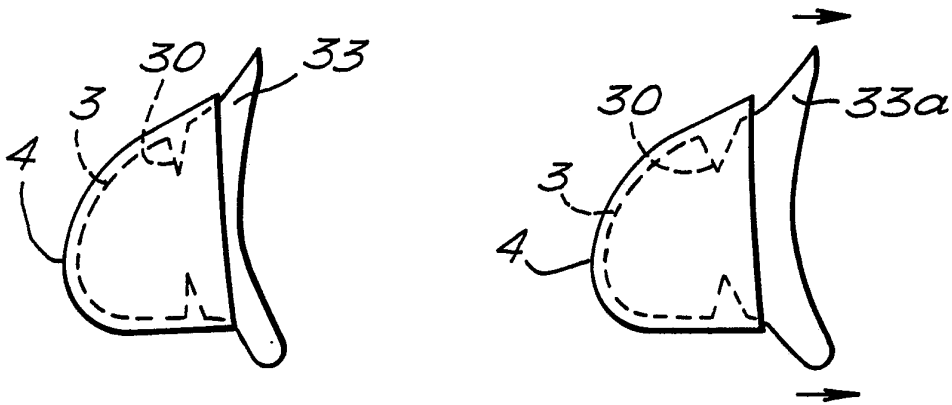

FIG. 9.



5/5

FIG. 10.

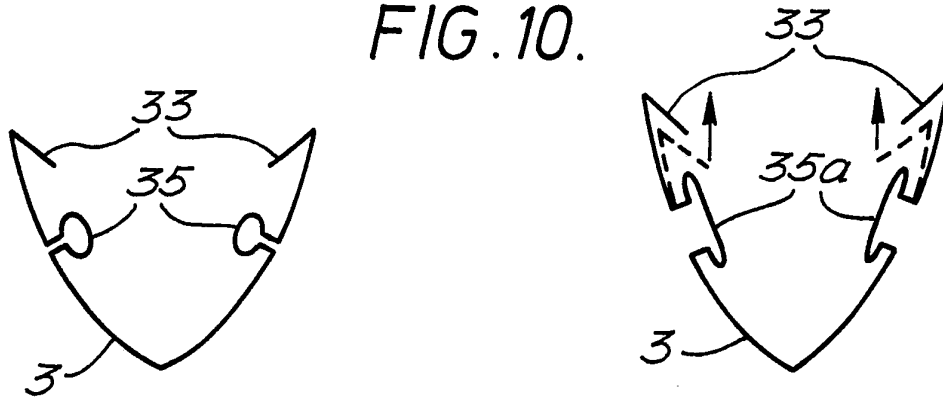

FIG. 11.

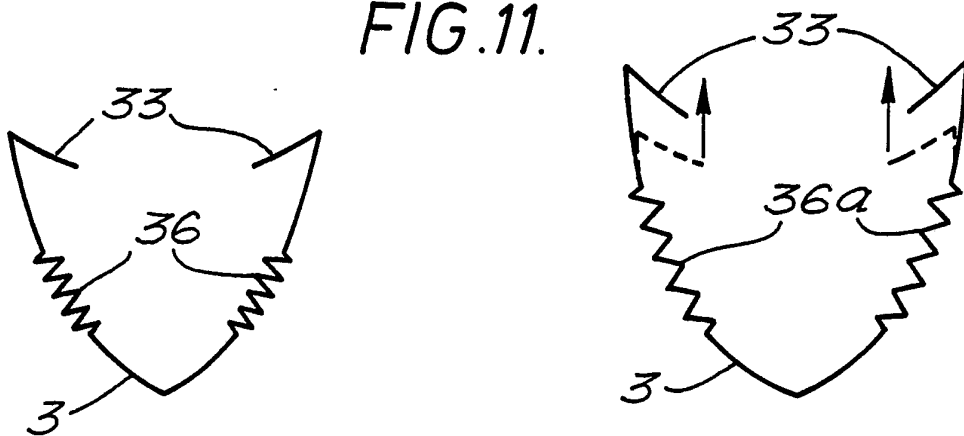
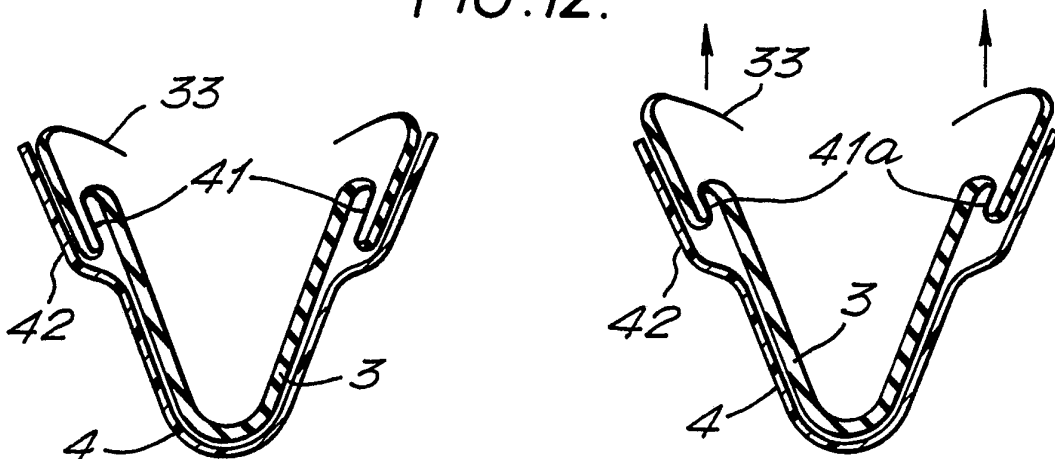

FIG. 12.



INTERNATIONAL SEARCH REPORT

PCT/GB 91/01034

International Application No

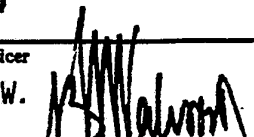
| | | |
|---|--|-------------------------------------|
| I. CLASSIFICATION OF SUBJECT MATTER (if several classification symbols apply, indicate all) ⁶ | | |
| According to International Patent Classification (IPC) or to both National Classification and IPC Int.Cl. 5 A62B18/02 ; A62B18/08 | | |
| II. FIELDS SEARCHED | | |
| Minimum Documentation Searched ⁷ | | |
| Classification System | Classification Symbols | |
| Int.Cl. 5 | A62B ; B64D | |
| Documentation Searched other than Minimum Documentation to the Extent that such Documents are Included in the Fields Searched ⁸ | | |
| | | |
| III. DOCUMENTS CONSIDERED TO BE RELEVANT⁹ | | |
| Category ^o | Citation of Document, ¹¹ with indication, where appropriate, of the relevant passages ¹² | Relevant to Claim No. ¹³ |
| E | FR,A,2 657 264 (ULMER) 26 July 1991 see the whole document --- | 1,2,4-7 16,17 |
| A | GB,A,826 198 (FRANKENSTEIN) 31 December 1959 see claim 1; figures --- | 1,17 |
| A | US,A,3 330 274 (BENNETT) 11 July 1967 see figures --- | 1,17 |
| A | US,A,3 513 841 (SEELER) 26 May 1970 see abstract; figures --- | 1,17 |
| A | US,A,2 348 108 (BULBULIAN) 2 May 1944 --- | |
| <p>^o Special categories of cited documents :¹⁰</p> <p>"A" document defining the general state of the art which is not considered to be of particular relevance</p> <p>"E" earlier document but published on or after the international filing date</p> <p>"L" document which may throw doubts on priority claim(s) or which is cited to establish the publication date of another citation or other special reason (as specified)</p> <p>"O" document referring to an oral disclosure, use, exhibition or other means</p> <p>"P" document published prior to the international filing date but later than the priority date claimed</p> <p>"T" later document published after the international filing date or priority date and not in conflict with the application but cited to understand the principle or theory underlying the invention</p> <p>"X" document of particular relevance; the claimed invention cannot be considered novel or cannot be considered to involve an inventive step</p> <p>"Y" document of particular relevance; the claimed invention cannot be considered to involve an inventive step when the document is combined with one or more other such documents, such combination being obvious to a person skilled in the art.</p> <p>"&" document member of the same patent family</p> | | |
| IV. CERTIFICATION | | |
| Date of the Actual Completion of the International Search | Date of Mailing of this International Search Report | |
| 22 OCTOBER 1991 | 20. 11. 91 | |
| International Searching Authority | Signature of Authorized Officer | |
| EUROPEAN PATENT OFFICE | WALVOORT B.W.  | |

**ANNEX TO THE INTERNATIONAL SEARCH REPORT
ON INTERNATIONAL PATENT APPLICATION NO. GB 9101034
SA 49031**

This annex lists the patent family members relating to the patent documents cited in the above-mentioned international search report. The members are as contained in the European Patent Office EDP file on
The European Patent Office is in no way liable for these particulars which are merely given for the purpose of information. 22/10/91

| Patent document cited in search report | Publication date | Patent family member(s) | Publication date |
|--|------------------|-------------------------|------------------|
| FR-A-2657264 | 26-07-91 | None | |
| GB-A-826198 | | None | |
| US-A-3330274 | | None | |
| US-A-3513841 | 26-05-70 | None | |
| US-A-2348108 | | None | |