

(19) **DANMARK**



Patent- og
Varemærkestyrelsen

(10) **DK/EP 3425401 T3**

(12) **Oversættelse af
europæisk patentskrift**

-
- (51) Int.Cl.: **G 01 N 33/579 (2006.01)** **B 01 L 3/00 (2006.01)** **G 01 N 21/17 (2006.01)**
- (45) Oversættelsen bekendtgjort den: **2023-10-23**
- (80) Dato for Den Europæiske Patentmyndigheds bekendtgørelse om meddelelse af patentet: **2023-09-27**
- (86) Europæisk ansøgning nr.: **17192314.7**
- (86) Europæisk indleveringsdag: **2013-10-07**
- (87) Den europæiske ansøgnings publiceringsdag: **2019-01-09**
- (30) Prioritet: **2012-10-08 US 201261710908 P** **2012-10-08 US 201261710898 P**
2012-10-08 US 201261710990 P **2012-10-08 US 201261710903 P**
- (62) Stamansøgningsnr: **13779696.7**
- (84) Designerede stater: **AL AT BE BG CH CY CZ DE DK EE ES FI FR GB GR HR HU IE IS IT LI LT LU LV MC MK MT NL NO PL PT RO RS SE SI SK SM TR**
- (73) Patenthaver: **BL Technologies, Inc., 5951 Clearwater Drive, Minnetonka, MN 55343, USA**
- (72) Opfinder: **GODEC, Richard Douglas, 6060 Spine Road, Boulder, Colorado 80301, USA**
MELANSON, Paul Charles, 6060 Spine Road, Boulder, Colorado 80301, USA
STONESMITH, Matthew Kaddeland, 6060 Spine Road, Boulder, Colorado 80301, USA
Xu, Hong, 1800 Cai Lun Road, Zhanjiang High-tech Park, 201203 Shanghai, Kina
Huang, Yan, 1800 Cai Lun Road, Zhanjiang High-tech Park, 201203 Shanghai, Kina
- (74) Fuldmægtig i Danmark: **Plougmann Vingtoft A/S, Strandvejen 70, 2900 Hellerup, Danmark**
- (54) Benævnelse: **FORFYLDTE TESTSUBSTRATER TIL TEST AF LAL-REAKTIVE STOFFER, ANVENDELSESFREMGANGSMÅDER OG FREMSTILLINGSFREMGANGSMÅDER**
- (56) Fremdragne publikationer:
US-A1- 2005 048 655
US-A1- 2011 201 049
A P Gee ET AL: "A Multi-Center Comparison Study between the Endosafe ? PTS(TM) Rapid Release Testing System and Traditional Test Methods for Detecting Endotoxin in Cell Therapy Products", , 22 August 2008 (2008-08-22), XP055099027, Retrieved from the Internet: URL:http://www.ncbi.nlm.nih.gov/pmc/articles/PMC2518960/pdf/nihms54780.pdf [retrieved on 2014-01-29]
&: "Endotoxin Detection: Products and Services", , 1 May 2010 (2010-05-01), pages 1-36, XP055099545, Retrieved from the Internet: URL:http://www.rtc.rs/fileadmin/assets/documents/teasers/Endotoxin_Detection.pdf [retrieved on 2014-01-30]
Anonymous: "Endosafe Cartridge Technology", , 1 January 2017 (2017-01-01), pages 1-9, XP55625222, Retrieved from the Internet: URL:https://www.criver.com/sites/default/files/resources/EndosafeCartridgeTechnology_Brochure.pdf [retrieved on 2019-09-23]
ANONYMOUS: "Charles River", ENDOSAFE CARTRIDGE TECHNOLOGY, 8 July 2019 (2019-07-08), pages 1-9,

DESCRIPTION

FIELD OF THE INVENTION

[0001] The invention relates to the field of determining the concentration of LAL-reactive substances in a sample. More specifically, the invention relates to preloaded test substrates and new measurement methods compatible with the United States, European, and Japanese Pharmacopeia Bacterial Endotoxins Tests ("BET") and global equivalent pharmacopeia BET standards.

CROSS-REFERENCE TO RELATED APPLICATIONS

[0002] This application is entitled to the benefit of Provisional Patent Application Serial No. 61/710,908 filed October 8, 2012 and titled MICROFLUIDIC BACTERIA ENDOTOXIN TESTING METHOD AND APPARATUS; Provisional Patent Application Serial No. 61/710,990 filed October 8, 2012 and titled CENTRIPETAL MICROFLUIDIC PLATFORM FOR BACTERIAL ENDOTOXIN TESTING; Provisional Patent Application Serial No. 61/710,898 filed October 8, 2012 and titled SENSITIVE AND RAPID METHOD FOR DETECTION OF LOW LEVELS OF ENDOTOXINS USING LAL REAGENTS; and Provisional Patent Application Serial No. 61/710,903 filed October 8, 2012 and titled MICROPLATES PRELOADED WITH ENDOTOXIN DETECTION REAGENTS WITH CALIBRATION MEANS. All of the above listed applications are herein incorporated by reference.

BACKGROUND OF THE INVENTION

[0003] Microbial contamination, such as gram positive bacteria, gram negative bacteria, yeast, and fungi may cause severe illness and even death in humans. When people become infected with gram negative bacteria, the bacteria may produce fever-inducing bacterial endotoxins. Endotoxins can be dangerous and even deadly to humans. Endotoxin molecules, which are lipopolysaccharide components of cell walls of gram negative bacteria, can be present in drug formulations and surfaces of medical devices, independent of microbial contamination. Endotoxin contamination can happen even if a system passes a sterility test, which is why an independent endotoxin test is required.

[0004] Currently, a variety of tests have been developed to detect the presence of endotoxin in or on the sample being tested using hemocyte lysates from horseshoe crabs. Clotting will occur when the hemocyte lysate is exposed to the endotoxin. Hemocyte lysate is an amebocyte lysate produced from the hemolymph of various horseshoe crab species, including the *Limulus*, *Tachypleus*, and *Carcinoscorpius* species. A commonly used amebocyte lysate is produced from the hemolymph of *Limulus*, or *Tachypleus* species, is referred to as *Limulus*

amebocyte lysate ("LAL"). Routine tests that use LAL as a test reagent include gel clot assays, end point turbidimetric assays, kinetic turbidimetric assays, endpoint chromogenic assays, and kinetic chromogenic assays. Tests that use LAL reagent may also be used to test for glucans, a marker for fungal contamination.

[0005] More information on LAL assays and the standards used may be found in United States Pharmacopeia ("USP") Chapter 85 "Bacterial Endotoxins Test" ("BET"), Japanese Pharmacopeia 4.01 "Bacterial Endotoxin Test", European Pharmacopoeia 2.6.14 "Bacterial Endotoxins", and other equivalent national Pharmacopeias. Many of the Pharmacopeias listed above have been harmonized. Additional internationally harmonized pharmacopeia information can be found in ICH Q4B Annex 14 "Bacterial Endotoxin Test General Chapter". For endotoxin testing in medical devices, information can be found in USP Chapter 161 "Transfusion and Infusion Assemblies and Similar Medical Devices" and ANSI/AAMI ST72 "Bacterial endotoxins - Test methods, routine monitoring, and alternatives to batch testing". These standards and procedures may be generally referred to as compendia. Lonza, Endotoxin Detection, 2010. pg 1-36. discloses 4 separate vials of lysate (detection reagent) and endotoxin standard (LAL reactive standard) dilutions sufficient for 200 tests ("Pyrogen™ ultra Gel Clot LAL Assays"). These bulk liquids are then intended for pipetting into e.g. 96-well plates by the customer in the laboratory.

[0006] Manufacturers in the pharmaceutical, medical device, and food industries must meet certain standards to make sure their products do not contain microbial or endotoxin contamination. These industries require frequent, accurate, and sensitive testing for the existence of endotoxins to meet various safety standards, such as those set by the United States Food and Drug Administration, or the Environmental Protection Agency. These agencies accept many of the compendia procedures standards. Thus, if manufacturers want to obtain government approval to release a new product to market, many of the FDA requirements may be met if the products comply with the methods and standards in the compendia listed above. This can substantially reduce the cost to manufacturers to obtain FDA approval of new products.

[0007] These assays in the various compendia require aqueous solutions comprising known concentrations of an endotoxin for use as "standards". These aqueous solutions are typically unstable; therefore they are usually made from powdered toxins at the test location just prior to testing. The LAL reagent also usually comes in powder form and must be reconstituted in an aqueous solution before use.

[0008] Typically, only a few milligrams of the endotoxin and LAL powders are required, therefore accurate measurement of these powders may be tedious. Due to their fine particle size, these powders often stick to container and spatula surfaces, and are difficult to confine in the containers during testing procedures, posing additional handling problems. Using the conventional test methods, a skilled operator must manually reconstitute the endotoxin and LAL powders into endotoxin-free water while not contaminating the reagent solutions with laboratory equipment or through environmental contact.

[0009] Preparation of the endotoxin and LAL powders is difficult due to the slow solvation of the critical biological molecules and their propensity to stick to surfaces during mixing and condense on surfaces afterwards. The LAL reagent also starts reacting slowly upon reconstitution and has a very short shelf life. While the best practice would be to mix these immediately before use, workflow typically dictates mixing them at the start of the process. Also, the process of preparation is prone to contamination from endotoxins which are ubiquitous in the environment.

[0010] The agencies also require a series of calibration tests to ensure the equipment and reagents used are functioning properly. The calibration tests and sample measurements must also be made more than once. The current laboratory method of complying with BET and other compendia is very detailed and requires repetitive and highly precise measuring of fluid volumes for distribution into multiple inlets of a microplate or the like without contamination.

[0011] The most common method of performing an LAL analysis is with a microwell plate and reader. A matrix of reaction wells, open at the top and with a clear window on the bottom, are placed in a heated spectrophotometric reader used for multiple, simultaneous assays. There are many drawbacks, including the lengthy time it takes to prepare the plate, its high cost, the opportunity for mistakes and contamination, and the need to have the work done by a technician specifically trained for and dedicated to this task.

[0012] Highly skilled operators are continuously monitored to ensure proper technique and accuracy of measurement and testing, and the operators are retrained as needed so as to ensure accuracy of the repetitive actions. Typical methods may have as many as 248 slow and time consuming pipetting steps, making it an error prone method due to its complexity and contamination prone due to its length and number of manipulations.

[0013] Methods and devices have been developed to reduce the amount of steps or automated some or all of the steps in endotoxin testing. Some methods include automating one or more pipetting or aliquoting steps, automated mixing of samples, or preloading reagents in test substrates that allow only a very limited number of tests.

[0014] Other automated methods rely on robotics to measure and distribute samples and reagents in a microplate. Once prepared, the plate is loaded in a reader, either manually or using another robot. The robot is typically a pipette-based dispensing system which accurately transfers samples and reagents from a vial rack to the plate, replacing pipette tips to prevent cross-contamination. This is an expensive system which needs frequent validation of its robotic operations and may use multiple disposable, pipettes, tips, multiwell plates, dilution tubes, pipette filling trays, sampling vials, etc. for each run. It also prepares the wells in sequence, and like manual preparation, cannot start all the reactions simultaneously. Contamination is still an issue and since the process is typically unmonitored, there is no legitimate way of rejecting contaminated samples for cause.

[0015] All of the developed methods or devices, however, are missing one or more of the following aspects, low cost automation designed into the substrate, disposable clean substrate to insure cleanliness, compendial testing compliance on each substrate, built in individual test measurement validation, and simplicity of measurement operation. Accordingly, there exists a need for a more semi-automated testing method or procedure for testing and analyzing the endotoxin concentration in a fluid sample which reduces or eliminates the amount of potential operator error that complies with compendia.

BRIEF DESCRIPTION OF THE INVENTION

[0016] Accordingly, test substrates and methods are disclosed wherein the number of steps are reduced significantly, thereby minimizing contamination, timing delays and mismatches, and thus, improving accuracy. The methods are suitable for use with FDA-licensed LAL. The disclosed test substrates and measurement methods are suitable for use in pharmaceutical and biopharmaceutical manufacturing and are compatible with the United States, European, and Japanese Pharmacopeia Bacterial Endotoxins Tests and global equivalent pharmacopeia BET standards. For medical device manufacturing, the disclosed embodiments are compatible with endotoxin regulations and standards found in the international Pharmacopeia and consensus standards organizations and global equivalent standards.

[0017] This invention improves the standard Bacterial Endotoxins Test ("BET") by the creation of specialized test substrates with detection reagents (may be endotoxin detection reagents and/or LAL-reactive standards preloaded onto the test substrate. The test reagent being: at least one LAL-reactive standard, or at least one detection reagent and at least one LAL-reactive standard is at least partially dry, physically immobilized on the test substrate. In one embodiment, a preloaded test substrate is disclosed wherein the preloaded test substrate has been preloaded with at least one detection reagent and/or at least one LAL-reactive standard. These preloaded test substrates may be used in tests for determining the concentration of LAL-reactive substances in an aqueous sample. As used herein LAL-reactive substance means a substance that reacts with detection reagents. Examples of LAL-reactive substances include endotoxin or 1,3-P-D-glucans such as laminarin and curdlan. LAL-reactive standards comprise LAL-reactive substances therein. The present invention may also be used with any commercial source of detection reagents. Suitable detection reagents for detecting LAL-reactive substances include Amoebocyte Lysate (Limulus Polyphemus or LAL and Tachypleus Tridentatus or TAL), Recombinant Horseshoe Crab Factor C or rFc, Monocyte Activation Type Pyrogen reagents, a mixture of recombinant Factor C and LAL, and preparations that include sushi peptides, sushi peptide fragments, sushi peptide dimers, and other specific binding proteins such as antibodies and receptor binding proteins derived from bacteriophages, and any other reagents capable of reacting with Lipid A to produce a measurable response.

[0018] The present invention may reduce the number steps the user has to perform in preparing and measuring both the calibration standards and samples. This may reduce the need for a high level of skill, experience, and training, and reduces costs, times, and the

opportunity for human error. In addition the invention may be configured or utilized in a manner that complies with compendia requirements and FDA regulations.

[0019] The invention is also suitable for use with all quantitative compendia photometric methods of relating the reaction progress to endotoxin levels, including 1) kinetic chromogenic, where the time until the optical absorption changes by a specified amount is related to concentration, 2) endpoint chromogenic, where the optical absorption change over a fixed time is related to concentration, 3) kinetic turbidimetric, where the time unit the turbidity (usually measured by optical absorption) changes by a specified amount is related to concentration, and 4) endpoint turbidimetric, where the turbidity change over a fixed time is related to concentration.

[0020] In another embodiment, at least a portion of the preloaded test substrate may have a modified surface. The surface may be modified using plasma etching. Alternatively, the surface may be modified using at least one coating. The coating may be a static coating, a dynamic coating, or combinations thereof. Suitable static coatings include, but are not limited to, polyethylene glycol (PEG), collagen, and combinations thereof. Suitable dynamic coatings include, but are not limited to, polyethylene glycol (PEG), sodium deoxycholate, and combinations thereof.

[0021] In yet another embodiment, the preloaded test substrate may have at least one mechanical barrier between at least one of the portions. The mechanical barrier may be soluble. The preloaded test substrate may further comprise a portion identification mechanism, such as a tracer. In another embodiment, the preloaded test substrate may be a microplate. In yet another embodiment, the preloaded test substrate may have a barrier material to protect the preloaded test substrate from environmental exposure and surface contamination.

[0022] In another embodiment, a method for measuring a LAL-reactive substance in a sample is disclosed. The method comprises contacting the sample with a preloaded test substrate wherein at least a portion of the preloaded test substrate has been preloaded with at least one detection reagent and/or at least one LAL-reactive standard, thereby making a prepared sample. The test reagent being: at least one LAL-reactive standard, or at least one detection reagent and at least one LAL-reactive standard, is at least partially dry, physically immobilized on said test substrate. An absorbance of the sample may then be measured.

[0023] In another method embodiment, at least a portion of the preloaded test substrate may have a modified surface. The surface may be modified using plasma etching. Alternatively, the surface may be modified using at least one coating. The coating may be a static coating, a dynamic coating, or combinations thereof. Suitable static coatings include, but are not limited to, polyethylene glycol (PEG), collagen, and combinations thereof. Suitable dynamic coatings include, but are not limited to, polyethylene glycol (PEG), sodium deoxycholate, and combinations thereof.

[0024] In yet another embodiment, the preloaded test substrate may be a microplate. In yet

another embodiment, the preloaded test substrate may have a barrier material to protect the preloaded test substrate from environmental exposure and surface contamination.

[0025] In another embodiment, a method for depositing at least one test reagent on a microplate is disclosed. Test reagents may be any reagent that aids in testing samples. Suitable test reagents include, but are not limited to detection reagents and LAL-reactive standards. Suitable detection reagents are described above and may comprise amoebocyte lysate. LAL-reactive standards are also described above and include a USP Endotoxin Reference Standard (RSE) that has been calibrated to the current World Health Organization International Standard for Endotoxin. The method may comprise providing a test substrate having a well array comprising a plurality of wells, wherein each well has at least one optical window surface and a plurality of non-optical window surfaces. A first liquid solution having at least one detection reagent therein may be placed on a first non-optical window surface of at least one well. The first liquid solution may be dried on the first non-optical window surface thereby depositing the detection reagent on the first non-optical surface to form a preloaded test substrate.

[0026] The method for depositing at least one test reagent on a test substrate further comprises placing a second solution having at least one LAL-reactive standard therein on a second non-optical window surface of different wells, and wherein said LAL-reactive standard is present in a plurality of concentrations and each concentration is present in a different well. The second liquid solution is dried on the second non-optical window surface thereby depositing the LAL-reactive standard on the second non-optical window surface.

[0027] In another embodiment, the test substrate may be a microplate. In yet another embodiment, the method may further comprise covering the preloaded test substrate with a barrier material after the drying step to protect the preloaded test substrate from environmental exposure and surface contamination.

BRIEF DESCRIPTION OF THE DRAWINGS

[0028] Fig. 1 shows an embodiment of the invention wherein a test reagent may be deposited on the sidewalls of a microplate.

DETAILED DESCRIPTION OF EXEMPLARY EMBODIMENTS

[0029] In one embodiment, a preloaded test substrate is disclosed wherein the preloaded test substrate has been preloaded with at least one detection reagent and/or at least one LAL-reactive standard. The preloaded test substrate is designed to measure the BET in samples. It may also be used to provide calibration data from known spikes using a LAL-reactive standard. The preloaded test substrates may be designed to meet all the current BET pharmaceutical

regulations requirements and may be used with turbidimetric, chromogenic, and gel-clot BET methods. The LAL-reactive standard may be endotoxin that has been calibrated to the relevant regulatory master endotoxin (CSE) and the regulatory master endotoxin standard (RSE). Where other methods are acceptable or have been validated as being equivalent and acceptable to regulatory agencies, a stored calibration based on historical data can be used instead of the results from individual standards.

[0030] Accordingly, preloaded test substrates and methods are disclosed wherein the number of testing steps are reduced significantly, thereby minimizing contamination, timing delays and mismatches, and thus, improving accuracy. The methods are suitable for use with FDA-licensed detection reagents. The methods may be used with a standard absorbance or microplate reader with built in thermal control, a mixer, and an optical reader to determine the BET results.

[0031] In another embodiment, the LAL-reactive standard may be preloaded in at least three different portions of the preloaded test substrate. These three different portions may form a calibration portion. The concentration of the LAL-reactive standard in each portion may be the same or different. If endotoxin is used, the first portion may have an amount such that when an aqueous sample (or blank water) is present in that portion, the endotoxin concentration in the sample ranges from 0.005 to 0.5 EU/mL. Similarly, the second portion may have an amount corresponding to a concentration ranging from 0.05 to 5.0 EU/mL and the third portion may have an amount corresponding to a concentration ranging from 0.5 to 50 EU/mL.

[0032] In another embodiment, at least two portions of the preloaded test substrate may form a sample measurement portion. The two portions may be loaded with a LAL-reactive standard to form spikes.

[0033] The detection reagent and/or LAL-reactive standard may be deposited onto various test substrates, such as onto the sidewalls of a microplate well to allow a sample blank measurement, onto the optical window of a microplate well, onto a soluble coating, or onto an optically translucent or reflective insoluble film. Alternatively, the test reagents may be added as dried beads or coarse particles, or deposited into a carrier media that is added to the test substrate.

[0034] In another embodiment, at least a portion of the preloaded test substrate may have a modified surface. The surface may be modified using plasma etching. Alternatively, the surface may be modified using at least one coating. The coating may be a static coating, a dynamic coating, or combinations thereof. Suitable static coatings include, but are not limited to, polyethylene glycol (PEG), collagen, and combinations thereof. Suitable dynamic coatings include, but are not limited to, polyethylene glycol (PEG), sodium deoxycholate, and combinations thereof.

[0035] In yet another embodiment, the preloaded test substrate may have at least one mechanical barrier between at least one of the portions. The mechanical barrier may be

soluble.

[0036] The test substrate with preloaded reagents may be packaged such it is sealed from the environment by using a barrier material that prevents moisture, bacteria, and endotoxin agents from contaminating the preloaded reagents. Accordingly, in yet another embodiment, the preloaded test substrate may have a barrier material to protect the preloaded test substrate from environmental exposure and surface contamination. In another embodiment, the preloaded test substrate may be a microplate.

[0037] Sample introduction errors may be further reduced by a plurality of optional identification mechanisms on the preloaded test substrate or in a reader configured to read or measure samples in the test substrate. The identification mechanisms may identify the sample to the user or notify the user if additional reagents are required. Suitable identifications means may include optical markers such as color markers, alphanumeric markers, or light emitting diodes. In one embodiment, the identification mechanism may be a tracer. A tracer is an inert compound that is added to a fluid to aid in determining the volume, fluid location and movement (fluid motions). The tracer may also be used to aid in validating the measurement data. Suitable tracers include, but are not limited to, dyes.

[0038] In another embodiment a method for measuring an endotoxin in a sample is disclosed. As used in this specification, the term "sample" may include not only the sample to be analyzed, but water that shows no reaction with the detection reagent or lysate employed at the detection limit. Samples of non-reactive water may also be referred to as "LAL Reagent Water", "Water for BET" or "Water for Injection".

[0039] The method may comprise contacting the sample with a preloaded test substrate wherein at least a portion of the preloaded test substrate has been preloaded with at least one detection reagent and/or at least one LAL-reactive standard, thereby making a prepared sample. An absorbance of the sample may then be measured.

[0040] The sample may contact more than one portion of the test substrate. The prepared sample contacting the preloaded test substrate may or may not come into contact with a test reagent. For example, the prepared sample may be a "blank" or negative control that does not contact any test reagent, or only comes into contact with a detection reagent. In another method, a portion of the substrate may be further preloaded with at least one LAL-reactive standard. If the LAL-reactive standard is an endotoxin standard, it may be present in a plurality of concentrations, wherein each concentration is present on a different portion of the substrate as described above. The endotoxins may be preloaded onto the substrate such that a "standard curve" may be generated as required in USP 85. In another embodiment, the plurality of endotoxin standard concentrations may be used to generate a standard curve.

[0041] In another method embodiment, at least a portion of the preloaded test substrate may have a modified surface. The surface may be modified using plasma etching. Alternatively, the surface may be modified using at least one coating. The coating may be a static coating, a

dynamic coating, or combinations thereof. Suitable static coatings include, but are not limited to, polyethylene glycol (PEG), collagen, and combinations thereof. Suitable dynamic coatings include, but are not limited to, polyethylene glycol (PEG), sodium deoxycholate, and combinations thereof.

[0042] In yet another embodiment, the preloaded test substrate may be a microplate. In yet another embodiment, the preloaded test substrate may have a barrier material to protect the preloaded test substrate from environmental exposure and surface contamination.

[0043] In another embodiment, a method for depositing at least one test reagent on a microplate is disclosed. Test reagents may be any reagent that aids in testing samples. Suitable test reagents include, but are not limited to detection reagents and LAL-reactive standards. Suitable detection reagents are described above and may comprise amoebocyte lysate. LAL-reactive standards are also described above and include a USP Endotoxin Reference Standard (RSE) that has been calibrated to the current World Health Organization International Standard for Endotoxin. The method may comprise providing a test substrate having a well array comprising a plurality of wells, wherein each well has at least one optical window surface and a plurality of non-optical window surfaces. A first liquid solution having at least one detection reagent therein may be placed on a first non-optical window surface of at least one well. The first liquid solution may be dried on the first non-optical window surface thereby depositing the detection reagent on the first non-optical surface to form a preloaded test substrate. The LAL-reactive standard may be present in a plurality of concentrations, wherein each concentration is present in a separate well of the test substrate.

[0044] In another embodiment, the method for depositing at least one test reagent on a test substrate may further comprise placing a second solution having at least one LAL-reactive standard therein on a second non-optical window surface. The second liquid solution may be dried on the second non-optical window surface thereby depositing the LAL-reactive standard on the second non-optical window surface.

[0045] In another embodiment, the test substrate may be a microplate. In yet another embodiment, the method may further comprise covering the preloaded test substrate with a barrier material after the drying step to protect the preloaded test substrate from environmental exposure and surface contamination. Suitable test substrates include any test substrate that aids in evaluating or testing a sample, such as microplates available from Sigma-Aldrich, or microtiter plates. As shown in FIG. 1, the microplate (100) may have multiple sample wells (102) arranged in a 2 by 3 rectangular matrix. Microplates typically have 6, 24, 96, 384, or 1536 wells. In one embodiment, the microplate (100) may have 96 wells (102). Although the holding capacity of individual wells within one microplate is usually the same, the holding capacity of the wells may vary from microplate to microplate. The sidewalls (104) and bottoms (106) of the wells (102) may be curved or straight, such that the wells are semi-spherical, cylindrical, or rectangular in shape. The plate may also comprise a substantially planar bottom surface (108) such that the microplate rests flat on working surfaces. Working surfaces may include, but are not limited to, the ground, lab bench tops, microplate readers, and heating

plates, as well as manufacturing surfaces such as, tables, conveyors, and rollers. It is also possible that the microplate does not rest on a working surface at all, but is suspended above the working surface via a suspension means such as hooks, clips, etc. The microplate may be made of a variety of materials, including polystyrene and polypropylene, or polycarbonate. An optical detection microplate may be made with polystyrene or other suitable polymer that does not interfere with the chemical performance of the test reagents with the sample. In some embodiments, titanium dioxide may be added to make the polystyrene white to aid in optical absorbance methods.

[0046] One or more portions of the test substrate may have modified surfaces. The portions with modified surfaces may include, but are not limited to, the sidewalls and wells. The surfaces may be modified by any means known to those of ordinary skill in the art, including but not limited to, applying a coating, radiation, plasma etching, UV light and ozone, or dissolved reagents which may dynamically cover the surface, so that the interaction of the surfaces and reagents or samples mimic that of standard microplate analysis so that the manufacturer's specifications or compendia standards for analysis are met.

[0047] In one embodiment, the surfaces of the test substrate may be modified to control the biochemical LAL and LAL-reactive substance interaction or to control the surface energy. Controlling the level of the surface chemical interaction with the reaction chemistries may improve the repeatability and accuracy of the biochemical performance. For example, materials suitable for manufacturing the test substrates may also biochemically inhibit or enhance the LAL or LAL-reactive substance reaction chemistry. This biochemical interaction between the material surface and the reaction chemistries may be controlled or reduced with the application of a coating or through a chemical modification of the surface. Additionally, the unmodified surface of the test substrates may have an undesirable surface energy for the microfluidics present on the test substrate. The surface energy may also be modified to a desired value through chemical modification or the addition of a coating to make the surface energy more hydrophilic or more hydrophobic, or to achieve any other surface energy between these states. By optimizing the surface energy, the microfluidics present on the test substrate may also be optimized.

[0048] Another means to modify test substrate surfaces include plasma etching, where the surface is modified by having it exposed to plasma to affect a particular final surface chemical structure. Different elements may be added to the plasma to modify the chemistry of the surface, for example, oxygen or ammonia. Additional means include the use of permanent static or dynamic surface coatings. Static surface coatings may be added to form a layer on the test substrate surface to change the surface character. Static surface coatings may be applied as a solution with a solvent and dried or applied by surface grafting wherein the coating is chemically bonded to the surface. Examples of static coatings that may be grafted or applied as a coating include, but are not limited to, polyethylene glycol (PEG) and collagen. Dynamic surface coatings may be added to the reagents, samples, or standards and coat the surface in situ as fluids move on the test substrate or in sample wells. Examples of dynamic coatings include, but are not limited to PEG and surfactants like sodium deoxycholate.

[0049] In one embodiment, the method may comprise providing a microplate having a well array comprising a plurality of wells, wherein each well has at least one optical window surface and a plurality of non-optical window surfaces; providing a liquid solution having at least one test reagent therein; placing the liquid solution on a first of said non-optical window surfaces of at least one well; and drying the liquid solution on the first non-optical window surface, thereby depositing the test reagent on the first non-optical window surface. In another embodiment, the deposition steps may be repeated on subsequent non-optical window surfaces such that additional test reagents are deposited on subsequent sidewall portions.

[0050] The test reagents may be added to non-optical window surfaces of the well, to allow an initial optical measurement of the sample before the test reagents have had a chance to mix. This is useful for determining the optical zero. In addition, each test reagent has an optical signature that may be used to check that the correct levels of test reagents are added, prior to the reaction beginning. In another embodiment, each test reagent may be tagged with an optical material that is inert to the endotoxin test reaction. If the user finds incorrect levels of the expected levels of test reagents prior to the reaction taking place (reaction lag phase period), then the user may reject the measurement test for that sample. This is of great value to the pharmaceutical user, as any Out Of Specification (OOS) test must be evaluated and explained.

[0051] In another method embodiment, the method may comprise providing a liquid solution having at least one test reagent therein; providing a microplate having a substantially planer bottom surface, a plurality of edges (110), and a well array, wherein the bottom surface is substantially parallel with respect to a horizontal working surface (112), and wherein the well array comprises a plurality of wells having a plurality of sidewalls. A first of the plurality of edges (110) may be tilted such that the first edge is inclined (114) in a generally perpendicular orientation with respect to the horizontal working surface, such that the bottom surface is no longer substantially parallel with respect to the working surface and such that a sidewall portion closest to the working surface is in a generally parallel orientation with respect to the working surface. The liquid solution may be placed (116) on the sidewall portion and then dried, thereby depositing the test reagent on the sidewall portion. Any means suitable to transferring a liquid may be suitable, including, but not limited to, a pipette, or a spray nozzle.

[0052] Any drying process is suitable for the present invention, as long as the drying process does not alter the reactivity of the test reagents. These drying processes include, but are not limited to, a vacuum drying process at ambient temperature or a freeze drying process (lyophilization). In yet another embodiment, the liquid solution may be dried at ambient temperature or freeze dried. It should be understood that the liquid solution need not be dried completely; it may be partially dried, especially if non-aqueous solvents are used. It is sufficient that the test reagent is physically immobilized after it is deposited such that it remains in place. There may be some liquid still present after the test reagent is immobilized if a glycerin paste is used, as in certain pharmaceuticals and other materials prepared for stable storage. The same process may be used with both round-walled and flat-walled wells. The tilt-position of the

microplate may be maintained during the deposition steps through the use of a supporting means such as a stand or brace.

[0053] In another embodiment, the microplate may be rotated and the deposition steps may be repeated with subsequent edges of the microplate such that additional test reagents are deposited on subsequent sidewall portions. In another method embodiment, at least one test reagent comprising an endotoxin detection reagent may be present in every well. In another method embodiment, at least one test reagent comprises an endotoxin standard. In yet another method embodiment, the endotoxin standard may be present in a plurality of concentrations, wherein each concentration is present in a different well. In yet another method embodiment, the microplate may further comprise a well identification mechanism.

[0054] Many approaches to the test reagent deposition may be used to reduce mixing time, bubble formation, resolubilization time, ease of manufacturing, and detection sensitivity. The approaches may encompass both chemical and physical means to produce the desired results. Chemical means may include the use of chemical additives. Examples of chemical additives include solubility enhancing agents, such as the saccharides sucrose, glucose, and mannitol, as well as anti-flaking agents, such as aqueous polymer solutions comprising poly(ethylene oxide), hydroxypropyl cellulose, or hydroxypropyl methyl cellulose, or agents designed to prevent degradation such as dextran and various saccharides such as lactose and trehalose. Physical means may include various coating, spraying, or drying techniques during the deposition process.

[0055] In some embodiments, a detection reagent may be deposited in every well. Alternatively, there is no detection reagent in any of the wells, allowing the user to add detection reagent from a preferred supplier. In one embodiment, the detection reagent may be amoebocyte lysate. The use of the natural absorption of LAL, or the addition of turbidimetric or chromogenic non-LAL reactive tracers to the LAL and endotoxin may also be used to reduce testing errors.

[0056] The LAL-reactive standard may be deposited in only a portion of the wells. In addition, various wells may be preloaded or predeposited with LAL-reactive standard with different concentrations of the LAL-reactive substance therein, such that the user merely has to add the sample to be tested to the wells. In one embodiment, the detection reagent and LAL-reactive substance may be deposited in the wells such that all of the tests and replicates required by USP 85 may be performed simply by adding the samples. In such an embodiment, each well comprises either a separate given test, or a replicate of a given test. In one embodiment, the lowest concentration may be confirmed in four replicates, wherein 4 of the 96 wells each comprise one replicate. Alternatively, the wells may be preloaded with LAL-reactive standards such that the inhibition/enhancement tests (or "spikes"), including replicates, may be performed. Alternatively, the wells may be preloaded such that the quantitative tests, wherein the concentration of bacterial endotoxins in a given sample is quantified, may be performed. In yet another embodiment, the wells may be preloaded such that all the tests and replicates required under USP 85, including the lysate sensitivity, the inhibition/enhancement, and

quantitative tests, may be performed on the same microplate. Similar concepts may be employed with any test substrate or any portion of a test substrate and are not limited to microplates with wells.

[0057] In one embodiment, the wells may be covered with a seal means, such as an adhesive label with adhesive only on the portions of the label outside the well opening. The seal means may be made of a barrier material that prevents the passage of water and oxygen, whereby the wells may be kept dry to a humidity level less than about 5%.

[0058] The disclosed methods may be used to pre-deposit LAL reagents, chromogenic reagents and endotoxin in pre-cleaned (endotoxin free) 96 or 384-well microplates. The test reagents, in a liquid solution, may be placed on the walls of the wells, or on the optical window surface of the optical well. The liquid solution may also comprise chemical additives such as solubility enhancing agents and anti-flaking agents. The disclosed methods allow the reagents to be deposited on the walls of the standard 96 or 384-well microplates without interfering with the optical window or the optical path, thereby allowing an initial sample absorption measurement.

[0059] In another embodiment, a test substrate is disclosed wherein at least a portion of the test substrate has been preloaded with at least one test reagent. The test substrate is suitable for optical monitoring of liquids and use in performing LAL assays for endotoxins or glucans.

[0060] Reagents for the LAL assays may be isolated in segments of the test substrate. The test substrate may be disposable. The test substrate may have a variety of forms, geometries and shapes, including a typical microplate shape. Other suitable forms include, but are not limited to, cards, cartridges, or discs. The test substrate may also be configured such that samples and fluids may be added to it. The test substrate also allows for mixing of samples as the test substrate is shaken, swirled, spun or rotated. The test substrate also allows for the optical monitoring of liquids.

[0061] The test substrate can be used for performing analytical functions including, but not limited to, measurement of samples with an added positive product control that is an endotoxin or glucan spike, measurement of water blanks (free of endotoxin or LAL reagent), measurement of a series of at least three calibration solutions. Moreover, the test substrate may be used for performing all the analytical functions listed in two or more duplicates.

[0062] The test substrate may be used with an optical apparatus or reader that measures the times between optical absorption states or the optical absorption change between times. The preloaded test substrate may also be used for confirmation that the reagents and analyzer meet specifications, calibration for conversion to endotoxin or glucan concentrations in the sample, validation of performance or meeting compendia or the optical apparatus manufacturers' specifications, and measurement of the samples being analyzed.

[0063] The test substrate may be made from any suitable material. In another embodiment,

portions of the test substrate may be coated with polymer materials, surface treatments, or coatings to meet compendia or the test reagent manufacturers' specifications. In yet another embodiment, a portion of the test substrate may be coated with a static coating to reduce LAL reagent or standard loss. Another portion of the test substrate may be coated with a dynamic coating of the microplate wells to reduce LAL reagent or standards loss. The dynamic coating may also be mixed with standards or reagents.

[0064] A portion of the test substrate may also be coated with additives to aid, or regulate, proper analysis and interactions of test reagents or sample materials. Exemplary additives include, but are not limited to solubility aids, transport aids, and stabilizers.

[0065] In yet another embodiment, the test substrate may comprise mechanical barriers separate reagents to prevent interaction as they are being isolated in the test substrate or being stored long-term. The barriers may be insoluble and arranged such that they do not interfere with optical measurements. Other barriers may be soluble to some extent so that they dissolve during measurement and do not interfere with it.

[0066] In yet another embodiment, the test substrate may be preloaded with standards and spikes made from control standard endotoxin (CSE) or reference standard endotoxin. The spikes may be stored as dried material so that they are at the correct concentration while not diluting or interfering with the sample being spiked.

EXAMPLE

[0067] The following example demonstrates an embodiment wherein endotoxin standards are preloaded onto the test substrate. The endotoxin standard range is shown in Table 1. The endotoxin standard range, however, may be different in other embodiments.

0.005 - 0.5	0.005	0.05	0.5
0.01-1	0.01	0.1	1
0.05 - 5	0.05	0.5	5
0.1 - 10	0.1	1	10
0.5 - 50	0.5	5	50

[0068] Table 2 is a description of the preloaded test substrate, wherein the test substrate has 96 portions. Column 1 indicates the portion of the test substrate. Column 2 indicates the sample that the operator must add to the test substrate. Each portion of the test substrate may be preloaded with a different endotoxin standard concentration as shown in Column 3. Column 4 is a description of the BET test that may be completed in each portion. The endotoxin detection reagent is not shown in Table 2 as all 96 portions may be preloaded with the same amount of an endotoxin detection reagent. Alternatively, the test substrate may not have any

endotoxin detection reagent, allowing the operator to add an endotoxin detection reagent from a preferred supplier.

1	Water for BET	0	Negative Control (Blank) Rep 1
2	Water for BET	0	Negative Control (Blank) Rep 2
3	Water for BET	0	Negative Control (Blank) Rep 3
4	Water for BET	Lowest	Lowest Detection Range Calibration Standard Rep 1
5	Water for BET	Lowest	Lowest Detection Range Calibration Standard Rep 2
6	Water for BET	Lowest	Lowest Detection Range Calibration Standard Rep 3
7	Water for BET	Mid Range	Mid Range Calibration Standard Rep 1
8	Water for BET	Mid Range	Mid Range Calibration Standard Rep 2
9	Water for BET	Mid Range	Mid Range Calibration Standard Rep 3
10	Water for BET	Highest	Highest Detection Range Calibration Standard Rep 1
11	Water for BET	Highest	Highest Detection Range Calibration Standard Rep 2
12	Water for BET	Highest	Highest Detection Range Calibration Standard Rep 3
13	Sample A	0	Sample A Analysis Rep 1
14	Sample A	0	Sample A Analysis Rep 2
15	Sample A	Mid Range	Positive Control Spike for Sample A Rep 1
16	Sample A	Mid Range	Positive Control Spike for Sample A Rep 2
17	Sample B	0	Sample B Analysis Rep 1
18	Sample B	0	Sample B Analysis Rep 2
19	Sample B	Mid Range	Positive Control Spike for Sample B Rep 1
20	Sample B	Mid Range	Positive Control Spike for Sample B Rep 2
21	Sample C	0	Sample C Analysis Rep 1
22	Sample C	0	Sample C Analysis Rep 2
23	Sample C	Mid Range	Positive Control Spike for Sample C Rep 1
24	Sample C	Mid Range	Positive Control Spike for Sample C Rep 2
25	Sample D	0	Sample D Analysis Rep 1
26	Sample D	0	Sample D Analysis Rep 2
27	Sample D	Mid Range	Positive Control Spike for Sample D Rep 1
28	Sample D	Mid Range	Positive Control Spike for Sample D Rep 2
29	Sample E	0	Sample E Analysis Rep 1
30	Sample E	0	Sample E Analysis Rep 2

31	Sample E	Mid Range	Positive Control Spike for Sample E Rep 1
32	Sample E	Mid Range	Positive Control Spike for Sample E Rep 2
33	Sample F	0	Sample F Analysis Rep 1
34	Sample F	0	Sample F Analysis Rep 2
35	Sample F	Mid Range	Positive Control Spike for Sample F Rep 1
36	Sample F	Mid Range	Positive Control Spike for Sample F Rep 2
37	Sample G	0	Sample G Analysis Rep 1
38	Sample G	0	Sample G Analysis Rep 2
39	Sample G	Mid Range	Positive Control Spike for Sample G Rep 1
40	Sample G	Mid Range	Positive Control Spike for Sample G Rep 2
41	Sample H	0	Sample H Analysis Rep 1
42	Sample H	0	Sample H Analysis Rep 2
43	Sample H	Mid Range	Positive Control Spike for Sample H Rep 1
44	Sample H	Mid Range	Positive Control Spike for Sample H Rep 2
45	Sample I	0	Sample I Analysis Rep 1
46	Sample I	0	Sample I Analysis Rep 2
47	Sample I	Mid Range	Positive Control Spike for Sample I Rep 1
48	Sample I	Mid Range	Positive Control Spike for Sample I Rep 2
49	Sample J	0	Sample J Analysis Rep 1
50	Sample J	0	Sample J Analysis Rep 2
51	Sample J	Mid Range	Positive Control Spike for Sample J Rep 1
52	Sample J	Mid Range	Positive Control Spike for Sample J Rep 2
53	Sample K	0	Sample K Analysis Rep 1
54	Sample K	0	Sample K Analysis Rep 2
55	Sample K	Mid Range	Positive Control Spike for Sample K Rep 1
56	Sample K	Mid Range	Positive Control Spike for Sample K Rep 2
57	Sample L	0	Sample L Analysis Rep 1
58	Sample L	0	Sample L Analysis Rep 2
59	Sample L	Mid Range	Positive Control Spike for Sample L Rep 1
60	Sample L	Mid Range	Positive Control Spike for Sample L Rep 2
61	Sample M	0	Sample M Analysis Rep 1
62	Sample M	0	Sample M Analysis Rep 2
63	Sample M	Mid Range	Positive Control Spike for Sample M Rep 1
64	Sample M	Mid Range	Positive Control Spike for Sample M Rep 2
65	Sample N	0	Sample N Analysis Rep 1
66	Sample N	0	Sample N Analysis Rep 2

67	Sample N	Mid Range	Positive Control Spike for Sample N Rep 1
68	Sample N	Mid Range	Positive Control Spike for Sample N Rep 2
69	Sample O	0	Sample O Analysis Rep 1
70	Sample O	0	Sample O Analysis Rep 2
71	Sample O	Mid Range	Positive Control Spike for Sample O Rep 1
72	Sample O	Mid Range	Positive Control Spike for Sample O Rep 2
73	Sample P	0	Sample P Analysis Rep 1
74	Sample P	0	Sample P Analysis Rep 2
75	Sample P	Mid Range	Positive Control Spike for Sample P Rep 1
76	Sample P	Mid Range	Positive Control Spike for Sample P Rep 2
77	Sample Q	0	Sample Q Analysis Rep 1
78	Sample Q	0	Sample Q Analysis Rep 2
79	Sample Q	Mid Range	Positive Control Spike for Sample Q Rep 1
80	Sample Q	Mid Range	Positive Control Spike for Sample Q Rep 2
81	Sample R	0	Sample R Analysis Rep 1
82	Sample R	0	Sample R Analysis Rep 2
83	Sample R	Mid Range	Positive Control Spike for Sample R Rep 1
84	Sample R	Mid Range	Positive Control Spike for Sample R Rep 2
85	Sample S	0	Sample S Analysis Rep 1
86	Sample S	0	Sample S Analysis Rep 2
87	Sample S	Mid Range	Positive Control Spike for Sample S Rep 1
88	Sample S	Mid Range	Positive Control Spike for Sample S Rep 2
89	Sample T	0	Sample T Analysis Rep 1
90	Sample T	0	Sample T Analysis Rep 2
91	Sample T	Mid Range	Positive Control Spike for Sample T Rep 1
92	Sample T	Mid Range	Positive Control Spike for Sample T Rep 2
93	Sample U	0	Sample U Analysis Rep 1
94	Sample U	0	Sample U Analysis Rep 2
95	Sample U	Mid Range	Positive Control Spike for Sample U Rep 1
96	Sample U	Mid Range	Positive Control Spike for Sample U Rep 2

[0069] This written description uses examples to disclose the invention, including the best mode, and also to enable any person skilled in the art to practice the invention, including making and using any devices or systems and performing any incorporated methods. The patentable scope of the invention is defined by the claims, and may include other examples that occur to those skilled in the art. For example, there are many other approaches to

depositing the reagents without intermixing the LAL and endotoxin and causing premature reaction.

REFERENCES CITED IN THE DESCRIPTION

Cited references

This list of references cited by the applicant is for the reader's convenience only. It does not form part of the European patent document. Even though great care has been taken in compiling the references, errors or omissions cannot be excluded and the EPO disclaims all liability in this regard.

Patent documents cited in the description

- [WO61710908A \[0002\]](#)
- [WO61710990A \[0002\]](#)
- [WO61710898A \[0002\]](#)
- [WO61710903A \[0002\]](#)

Non-patent literature cited in the description

- [LONZA Endotoxin Detection, 2010, 1-36 \[0005\]](#)

Patentkrav

1. Forfyldt testsubstrat til detektering af et LAL-reaktivt stof, hvor mindst en portion af nævnte forfyldte testsubstrat er blevet forfyldt med et testreagens, der er:

5 mindst en LAL-reaktiv standard, eller
 mindst et detektionsreagens og mindst en LAL-reaktiv standard;
 hvor nævnte testsubstrat er forfyldt således, at nævnte testreagens er i det
 mindste delvist tørt, fysisk immobiliseret på nævnte testsubstrat;
 hvor nævnte LAL-reaktive standard er til stede i en flerhed af
10 koncentrationer, og hver koncentration er til stede på en separat portion af
 nævnte forfyldte testsubstrat.

2. Det forfyldte testsubstrat ifølge krav 1, hvor mindst en portion af nævnte forfyldte testsubstrat er plasmaætsset.

15

3. Det forfyldte testsubstrat ifølge krav 1, hvor nævnte testreagens er i det mindste delvist tørret, idet der anvendes ikke-vandige opløsningsmidler.

4. Det forfyldte testsubstrat ifølge krav 1, yderligere omfattende mindst en
20 mekanisk barriere mellem mindst en af nævnte separate portioner.

5. Det forfyldte testsubstrat ifølge krav 4, hvor mindst en mekanisk barriere er opløselig.

25 **6.** Det forfyldte testsubstrat ifølge krav 1, hvor nævnte forfyldte testsubstrat yderligere omfatter en portionsidentifikationsmekanisme.

7. Det forfyldte testsubstrat ifølge krav 1, hvor nævnte forfyldte testsubstrat er en mikroplade.

30

8. Det forfyldte testsubstrat ifølge krav 1, hvor nævnte forfyldte testsubstrat yderligere omfatter et barrieremateriale til at beskytte nævnte forfyldte testsubstrat mod miljømæssig eksponering og overfladekontamination.

9. Fremgangsmåde til måling af et LAL-reaktivt stof i en prøve, hvilken fremgangsmåde omfatter:

- 5 (a) at bringe nævnte prøve i kontakt med et forfyldt testsubstrat, hvor i det mindste en portion af nævnte forfyldte testsubstrat er blevet forfyldt med et testreagens, der er:
- mindst en LAL-reaktiv standard, eller
- mindst et detektionsreagens og mindst en LAL-reaktiv standard;
- hvor nævnte testsubstrat er forfyldt således, at nævnte testreagens er i det mindste delvist tørt, fysisk immobiliseret på nævnte testsubstrat;
- 10 hvor nævnte LAL-reaktive standard er til stede i en flerhed af koncentrationer, og hver koncentration er til stede på en separat portion af nævnte testsubstrat, hvorved der dannes en fremstillet prøve; og
- (b) måling af en absorbans af nævnte fremstillede prøve.

15 **10.** Fremgangsmåden ifølge krav 9, hvor mindst en del af nævnte forfyldte testsubstrat er plasmaætsset.

11. Fremgangsmåden ifølge krav 9, hvor nævnte flerhed af LAL-reaktive standardkoncentrationer anvendes til at generere en standardkurve.

20

12. Fremgangsmåden ifølge krav 9, hvor nævnte forfyldte testsubstrat er en mikroplade.

13. Fremgangsmåden ifølge krav 9, hvor det forfyldte testsubstrat yderligere omfatter et barriremateriale til at beskytte nævnte forfyldte testsubstrat mod miljømæssig eksponering og overfladekontamination.

25

14. Fremgangsmåde til afsætning af mindst et testreagens på et testsubstrat, hvilken fremgangsmåde omfatter:

- 30 (a) at tage et testsubstrat med et brøndarray omfattende en flerhed af brønde, hvor hver brønd har mindst en optisk vinduesoverflade og en flerhed af ikke-optiske vinduesoverflader;
- (b) at anbringe en første flydende opløsning med mindst et detektionsreagens deri på en første ikke-optisk vinduesoverflade af mindst
- 35 en brønd;

- (c) at tørre nævnte første flydende opløsning på nævnte første ikke-optiske vinduesoverflade, hvorved detektionsreagenset afsættes på nævnte første ikke-optiske vinduesoverflade og danner et forfyldt testsubstrat;
- 5 (d) at anbringe en anden flydende opløsning med mindst en LAL-reaktiv standard deri på en anden ikke-optisk vinduesoverflade af forskellige brønde, og hvor den LAL-reaktive standard er til stede i en flerhed af koncentrationer, og hver koncentration er til stede i en anden brønd; og
- 10 (e) at tørre den anden flydende opløsning på nævnte anden ikke-optiske vinduesoverflade, hvorved nævnte LAL-reaktive standard afsættes på nævnte anden ikke-optiske vinduesoverflade.

15. Fremgangsmåden ifølge krav 14, hvor nævnte forfyldte testsubstrat er en mikroplade.

- 15 **16.** Fremgangsmåden ifølge krav 14, hvor nævnte fremgangsmåde yderligere omfatter at dække nævnte forfyldte testsubstrat med et barrieremateriale efter nævnte tørretrin for at beskytte nævnte forfyldte testsubstrat mod miljømæssig eksponering og overfladekontamination.

DRAWINGS

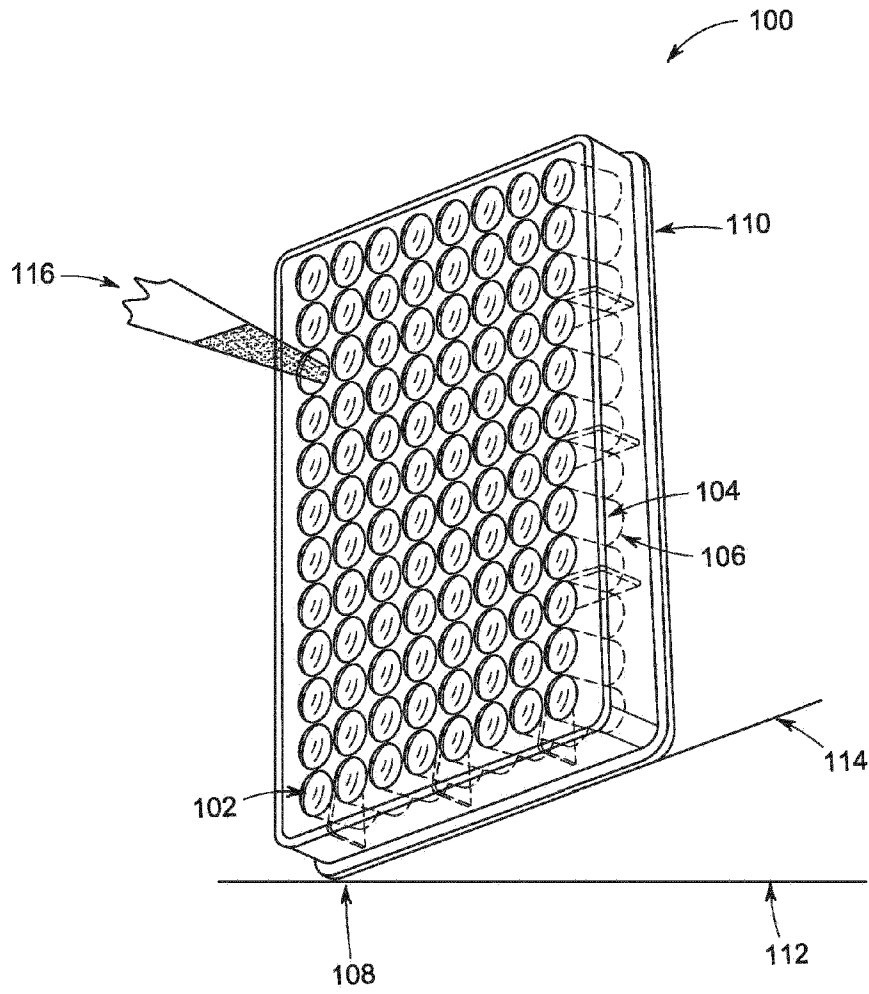

FIG. 1