

H. B. VAN VOORHIS.

Coal Stove.

No. 75,223.

Patented March 3, 1868.

Fig. 1.

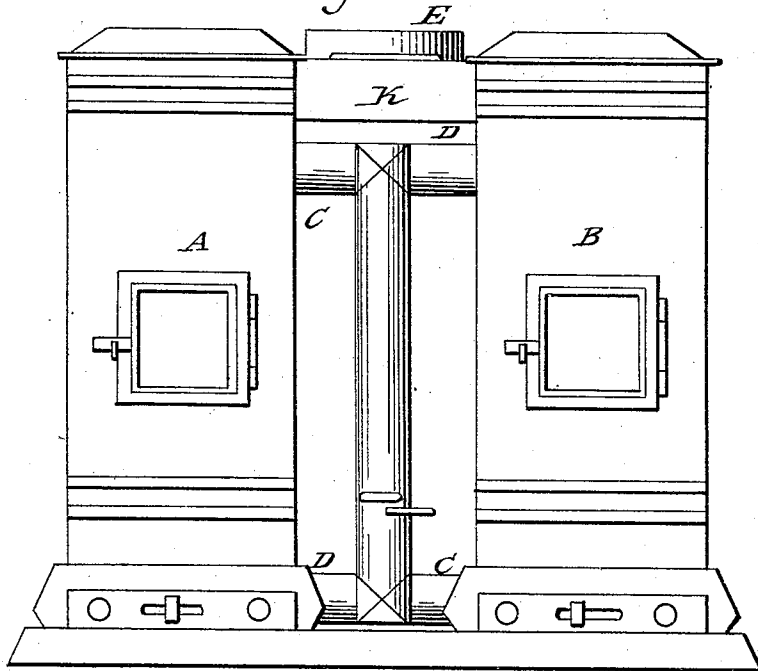
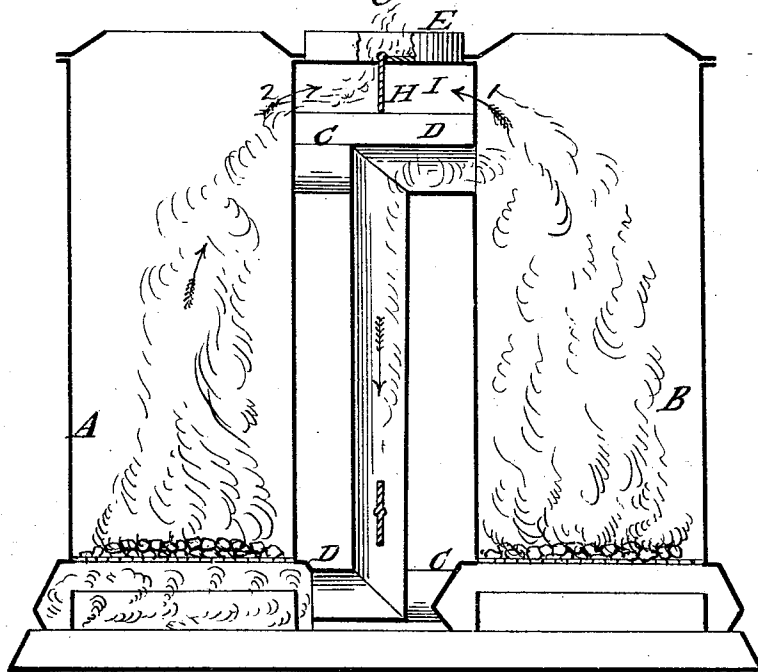

Fig. 2.



Witnesses:
Amelius
C. C. Pley

Inventor:
H. B. Van Voorhis
per
Alexander Mason

United States Patent Office.

H. B. VAN VOORHIS, OF PITTSBURG, PENNSYLVANIA.

Letters Patent No. 75,223, dated March 3, 1868.

IMPROVEMENT IN COAL-STOVES.

The Schedule referred to in these Letters Patent and making part of the same.

TO ALL WHOM IT MAY CONCERN:

Be it known that I, H. B. VAN VOORHIS, of Pittsburg, in the county of Allegheny, and in the State of Pennsylvania, have invented certain new and useful Improvements in Coal-Stoves; and do hereby declare that the following is a full, clear, and exact description thereof, reference being had to the accompanying drawings, and to the letters of reference marked thereon.

In the annexed drawings, making part of this specification, A and B represent two coal-stoves, of any suitable construction, which are placed side by side, a short distance apart, and connected together near their upper ends by means of a flue, K. A smoke-pipe, E, is placed and secured upon this flue. H represents a partition, which stands in a vertical position, and divides the flue K in two equal parts. J and I represent two chambers formed by the partition H. These chambers open into the smoke-pipe E. G represents a damper, which is hinged to the upper edge of partition H, and which turns either way to close or disclose the passages from chambers J and I to pipe E. When one of these passages is closed the other is open, the damper only closing one at a time. D represents a pipe with two elbows, which passes from stove B, near its upper end, down, and connects with stove A, beneath its fire-grate. C represents a similar pipe, which passes from stove A down and connects with stove B, beneath its grate. Each of these pipes is provided with a suitable damper.

In using this stove I make a fire in one side first, and then after it begins to burn well, I make a fire in the other side. Suppose the fire is made in stove A first, I open the damper G, so that the draught will pass up directly in the direction of arrow 2, until the fire gets a good start. I then make a fire in the other stove, and as soon as it begins to burn well, I close the damper over chamber J, open it over chamber I, close the damper of pipe D, and open the damper in pipe C. This throws the draught from stove A, through pipe C, and down under the grate of stove B, up through the coal of stove B, and thence out in the direction of arrow 1, to the smoke-pipe E.

By this arrangement I pass the smoke and gas, &c., of one stove through the fire of the other, and thus consume entirely every particle of gas, which would otherwise pass off with the smoke.

Figure 2 represents the fire in stove B sending its smoke and gas through the fire in stove A.

Having thus fully described my invention, what I claim as new, and desire to secure by Letters Patent, is—Connecting the stoves A and B together by flue K and pipes C D, in such a manner that the smoke of each can be passed beneath and through the fire of the other, substantially as and for the purpose set forth.

In testimony that I claim the foregoing, I have hereunto set my hand, this 24th day of January, 1868.

H. B. VAN VOORHIS.

Witnesses:

C. M. ALEXANDER,
J. McKENNEY.