

Aug. 29, 1933.

H. P. TAYLOR

1,924,760

METHOD OF PRESSING AND PACKING TOBACCO WITH NATURAL FINISH

Filed June 7, 1930

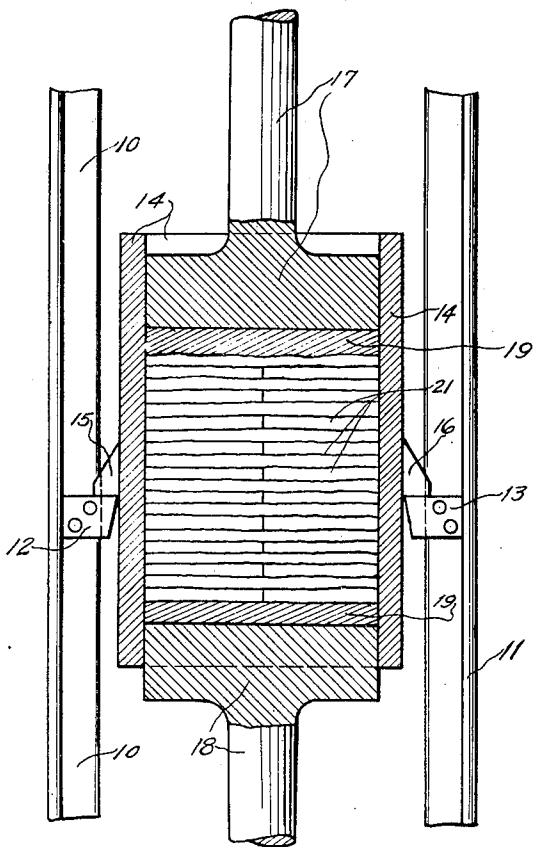

Fig. 1

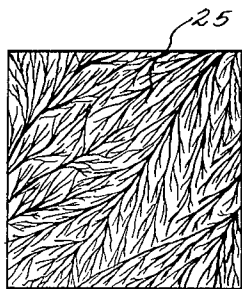

Fig. 4

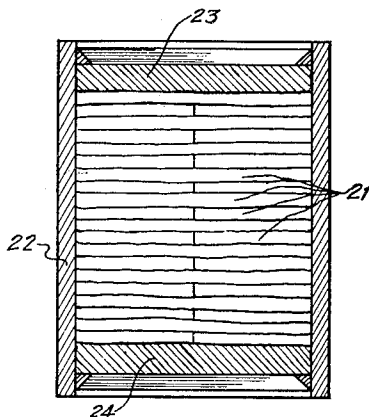

Fig. 3

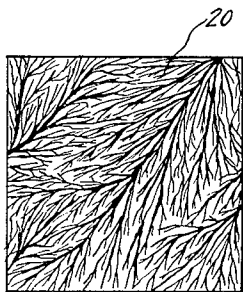

Fig. 2

H. P. TAYLOR,
INVENTOR.

BY *James E. Eaton*

ATTORNEY.

UNITED STATES PATENT OFFICE

1,924,760

METHOD OF PRESSING AND PACKING TOBACCO WITH NATURAL FINISH

Henry P. Taylor, Winston-Salem, N. C.

Application June 7, 1930. Serial No. 459,711

1 Claim. (Cl. 131—11)

An object of this invention is to provide means for pressing a mass of manufactured tobacco such as plug, twist, etc. together and to produce on the exterior of the mass of tobacco a natural rough and ready finish which corresponds to the finish imparted to the inside layers of the manufactured tobacco by said inside layers being pressed against each other.

Heretofore it has been the custom to press tobacco with top and bottom press members which are smooth and this causes the exterior plugs to have a slick or unnatural finish, and then this mass of tobacco is placed in the box or container and smooth surfaced heads are placed in the box, and it is seen that by examining the package of tobacco manufactured in this way that upon removing the top member of this box it will be noted that the top layers of tobacco have the same slick finish as has that side of the top member that comes into contact with the outside surface of the top layer of tobacco. Upon removing the entire mass of superimposed layers of tobacco it will be noted that the outside surface of the bottom layer of tobacco which came into contact with the inside surface of the bottom member of the box or container has the same slick or unnatural finish as has the inside surface of the bottom member. These outside surface finishes of the top and bottom layers of the mass of tobacco are what are known as unnatural finishes and it is one of the purposes of this invention to eliminate this unnatural surface finish and make these surface finishes similar to the surface finishes of the inside layers of the mass of manufactured tobacco, or any other predetermined surface finish that may be desired. These unnatural surface finishes cause the retail merchant to have to sell the pieces or plugs of manufactured tobacco, composing the top and bottom layers of the mass of manufactured tobacco, at a considerable reduction in price, which causes a very serious loss to the retail merchant and is further, a drawback or hindrance to the sale of manufactured tobacco. Upon examining the inside layers of the mass of manufactured tobacco it will be noticed that the surface finishes of these layers are a roughened, more or less, surface finish and this is known as the rough and ready finish. It will, further, be noted that the inside surface finishes, also, have, and show, the vein, fibre, and inheritant characteristics of the leaves of tobacco, with which each piece or plug of tobacco composing the layer is wrapped. These wrapping leaves are pressed tight to the pieces or plugs so that they become in fact a

part of the pieces or plugs of tobacco. The inside surface finishes, as above described, are capable of being sold at full value by the detail merchant to the consumer. It will be noted that there is a very distinct and decided difference in the surface finishes of the inside layers as compared to the outside surface finishes of the top and bottom layers of the mass of manufactured tobacco.

In the pressing of a mass or masses of superimposed layers of tobacco in presses, during the process of manufacture, what is known as top and bottom press plates are placed inside at the top and bottom of the press compartment between the mass of tobacco and the top and bottom of the pressing compartment. This invention will produce, or produces, or makes use of, a suitable, satisfactory low price material that can be used as press plates. This material as herein shown can be moulded, cast, or in other way herein shown, not only to any desired reasonable size, but, also, with a permanent surface finish identical, as herein described, to the surface finish of an inside layer of a mass of manufactured tobacco known as a natural finish. Further, plates made of this material will have some stretch or elasticity to them, and being of a non-grained, fibrous, nature will stretch or expand toward all sides or edges of the plate and thus keep the edges of such plates tight and snug against the inside sides of the pressing compartment in which they are used for a much longer time at a lower initial cost than does the present used type of press plate. The plates made of this substitute material can have one surface side each of the top and bottom plates made with an exact reproduction of the surface finish of an inside layer of the mass of pressed tobacco, herein described as a natural finish, such surface finish being placed next to the top layer of the top mass of tobacco to be pressed and to the outside surface of the bottom layer of the mass of tobacco to be pressed, the other sides of these plates contacting with the top and bottom members of the press or box or container in which they are used or contacting with each other where such plates are used as division plates.

Now when the plates and mass or masses of tobacco are placed in the pressing compartment and the pressing compartment sealed and locked tight and pressure applied to the plates and mass or masses of tobacco, these plates will impart to the outside surfaces of the top and bottom layer of the mass or masses of tobacco natural surface finishes identical with the natural surface finishes of inside layers of the mass of tobacco. This is not now done and cannot be done with the pres-

ent used type of press plate. It is very desirable to have press plates made and used as described in this invention so that, should no pressure be applied to the top member of the box or container when the mass of manufactured tobacco is put into it and sealed or fastened in by sealing or fastening the top member of the box or container in place, that the outside surfaces of the top and bottom layers of the mass of manufactured tobacco will have natural surface finishes identical with the natural surface finish of an inside layer of the mass of manufactured tobacco, and will be readily accepted by the customer at full market price, thus preventing loss to the retail merchant and enhancing the reputation of the product with the consumer and the retail merchant owing to the fact that there will be no undesirable unnatural surface finished layers in the manufactured product so finished. This feature alone will be of untold value to the manufacturer in increasing the popularity of such a manufactured article. It is one of the purposes of this invention to produce such plates to be used in presses or boxes or containers.

Another object of this invention is to fashion or make out of this same material suitable top and bottom members for boxes or containers for manufactured tobacco which will have on the surface of these top and bottom members, that come into contact with the outside surface of the top and bottom layers of the mass of manufactured tobacco an exact reproduction, in all the minute details, of the surface finish of an inside layer of the mass of manufactured tobacco, known as the natural surface finish, as herein above described. Then when the mass of manufactured tobacco is removed from the last press in which it has been pressed, and is placed in its proper size box or container and the top member fastened into place, these top and bottom members will insure that the outside surface finishes of the top and bottom layers of the mass of manufactured tobacco, with which they come in contact, will have, when such layers are presented to the consumer by the retail merchant, a natural surface finish, as herein above described, instead of the present slick or unnatural surface finish, as herein above described. Details of the production of this material and the imparting of natural surface finishes to this material will be described herein after.

It is here desired to again state what is known as the natural surface finish of an inside layer of the mass of manufactured tobacco. Such a natural surface finish is one showing a roughened, uneven, surface finish, and has on it, in addition to this roughened, uneven, surface finish, vein, fibre, and other characteristics of the leaves of tobacco with which each piece or plug of tobacco is wrapped and, also impressions of the vein, fibre, and other characteristics of leaves of tobacco with which the adjoining or contacting piece or plug of tobacco is wrapped; these contacting surfaces imparting to each other, under pressure, the characteristic surface finishes of each other. It is one of the purposes of this invention to have the surfaces of the above mentioned plates and the above mentioned top and bottom members of boxes and containers, that come into contact with the outside surfaces of top and bottom layers of the mass of manufactured tobacco made or finished in all the minute details, of the above described natural surface finishes of inside layers of the mass of manufactured tobacco.

At this point it is desired to state what is and

describe what is known as back pressure. Referring to that part of the process of manufacturing the above described mass of manufactured tobacco where this mass of manufactured tobacco is taken from the final press and placed in its box or container, it has been stated, that this mass of manufactured tobacco has been pressed in one or more presses. When such a mass of manufactured tobacco is taken out of the press the pieces or plugs composing the layers of this mass of tobacco have a strong tendency to swell back to approximately their original unpressed state of being, this swelling back being known as back pressure. When such a mass of manufactured tobacco is placed in its box or container, and the top member put or pressed into its place and securely and properly fastened to the box or container, this then confined mass of manufactured tobacco will exert, due to back pressure, a decided pressure against both the top and the bottom members of the box or container. This back pressure will cause the outside surfaces of the top and bottom layers of the mass of manufactured tobacco to press against the contacting surfaces of the top and bottom members of the box or container with enough pressure to have imparted, on these surfaces of layers of tobacco, impressions similar to those identical with the contacting surface finishes of the top and bottom members of the box or container. It is one of the purposes of this invention to utilize this back pressure to a favorable advantage instead of the present unfavorable result. Where such pressure is sufficient, (even though plates used in the presses with this mass of tobacco are of the herein above described present type of used plate resulting in slick, unnatural surface finishes of the outside surface of the top and bottom layers of the mass of manufactured tobacco) this back pressure, where the above described improved type of top and bottom members of boxes or containers are used, will cause the outside surface finishes of the top and bottom layers of the mass of manufactured tobacco to lose their slick unnatural finish and assume, in minute detail, the natural contacting surface finishes of the top and bottom members of the box or container.

Where this back pressure is sufficient, and the mass of manufactured tobacco tightly and securely confined in its wooden box or container, and the present used conventional type of slick smooth faced surface top and bottom members are used, even though the improved herein described type of press plates are used, this back pressure will cause the outside surfaces of the top and bottom layers of the confined mass of manufactured tobacco to assume, or largely assume, the slick smooth unnatural surface finish of the contacting surface of the top and bottom members, and the resulting surface finish of the outside surfaces of the top and bottom layers being easily distinguishable as unnatural surface finishes. Where the mass of manufactured tobacco is placed in a type box or container that is not of proper construction to resist back pressure, and the back pressure is largely overcome and eliminated by confining the mass of manufactured tobacco in boxes or containers for a period of time sufficient to largely overcome or eliminate this back pressure and the mass of manufactured tobacco then placed in its final box or container, which in many instances is a paste board box which is used for small packages of tobacco ranging from two to five pounds or even larger sizes, the use of these improved types of herein de-

scribed plates in both the presses and the next to final boxes or containers will insure the outside surface finishes of the top and bottom layers of the mass of manufactured tobacco having, and retaining natural surface finishes when placed in its final box or container. This above described use of these improved types of plates for use not only in presses, but also in boxes or containers is a purpose of this invention, and these plates can be used to advantage in the paste board box as heads for the same to insure that the tobacco will not assume a slick appearance after being packed in the box even though the back pressure has been almost entirely eliminated by confining the mass of tobacco in a second press.

It is well known that the surface faces of wood, especially those types of wood suitable and of sufficient strength to be used in the manufacture of all members entering into the construction of wooden boxes or containers for manufactured tobacco cannot be embossed, moulded, died, stamped, shaped or pressed, or in any other way, fashioned with any minute permanent detailed reproduction of exact, identical, duplicate surface finishes, such as the natural, rough and ready surface finishes of inside layers of the mass of manufactured tobacco as herein described. Wood is of a grained construction, or structural nature that does not permit this being done, and if it were possible to properly emboss or stamp it, as herein above described, with the natural surface finish of an inside layer of the mass of manufactured tobacco, the structural strength of the wood would be so weakened that it would be useless as a top and bottom member for a box or container for manufactured tobacco, and in addition, the cost of doing this would be so prohibitive as to eliminate attempts to do this. It is desired to state here that while attempts have been made to do this, the results from such attempts have been unsuccessful where the resulting top and bottom layers of the mass of manufactured tobacco have been offered to the consumer. Such attempts have not been able, for the reasons above herein stated, to reproduce the exact duplicate finish of the natural surface finish of an inside layer of the mass of manufactured tobacco.

This substitute product for wood board can be prepared in the following manner: Take any fibrous material including such as cane, stalks, straw, wood, or waste wood, pieces from lumbering operations or lumber mills, or cotton, and any other suitable material and macerate it into a mass of fibrous material. This macerating can be done by several methods, including such methods as placing the material to be macerated into cylinders or containers of sufficient strength and sealing up such cylinders or containers tight and securely with proper strength. Then through a proper opening or intake steam is injected into the container up to very high pressure. After a proper interval of time the steam will thoroughly impregnate the fibrous material so that when the discharge end of the cylinder or container is suddenly opened the steam and steam impregnated fibrous material will be discharged from the cylinder or container and the expansive pressure of the highly compressed steam will thoroughly explode the steam impregnated fibrous material reducing or changing it into a homogeneous non-grained mass of fibrous material. Another method which can be used to reduce or change the fibrous material to a non-grained fibrous mass is to place the fibrous mate-

rial into a tank of water with water and proper chemicals dissolved into the water in the tank and heating the water, chemicals and fibrous material to a sufficient temperature for a sufficient length of time. This will cause the individual fibers of the fibrous materials to separate one from the other and with the water, chemicals, and fibre and separated fibrous material, form a non-grained fibrous mass. It is not the purpose of this above description of ways of converting fibrous material into a non-grained fibrous mass to limit this invention to the use of material made only from or by these two described methods. Any properly prepared non-grained fibrous mass can be used.

The fibrous material having now been reduced or converted into a non-grained fibrous mass, such mass may be washed free of any chemicals used in the reducing or converting process and passed through rollers, presses, or other means that will press from it the surplus moisture. Then a proper and suitable binder, and, if desired, a suitable water proofing, may be applied to the washed out, squeezed out, non-grained fibrous mass so that when it is pressed, embossed, moulded, cast, shaped in any way, or vulcanized into any desired form it will properly hold together and become a solid, firm, non-grained, fibrous material that can be used in the place of wood products.

The moulds, presses, dies, or casting forms in which, and with which the non-grained fibrous mass is shaped and pressed may, or may not, be fitted with heating compartments for vulcanizing the non-grained fibrous mass.

These moulds, presses, dies, or casting forms, must be of proper material and of sufficient strength to withstand the pressure used in forcing and forming, stamping, or embossing and shaping, the non-grained fibrous mass into the desired form.

These moulds, presses, dies, or casting forms may have on that part of their surfaces that come into contact with the non-grained fibrous mass an exact reproduction of any design which it is desired to have reproduced on the surface mass.

When properly handled this finished product made from a non-grained fibrous mass will have as great or greater strength than has wood of the same weight and thickness and will not warp or splinter or crack as will wood. Further, the imparting to it of any desired design, including an exact reproduction of the natural surface finish of an inside layer of a mass of manufactured tobacco, as hereinbefore described, in all the exact, detailed minuteness of the design will not weaken its strength or change its structural nature as will happen to wood if it is attempted to stamp, emboss, or impress the wood with a similar design, and, further where such an attempt is made with wood it will be found owing to the structural nature of wood, not to successfully and completely be done.

For this reason alone the material made from a non-grained fibrous mass is of distinct advantage over wood, for uses where it is desired to exactly reproduce any desired design on this material to be used, and in turn use this piece of material to exactly reproduce its design on another suitable material, including a layer of a mass of manufactured tobacco, as hereinbefore set forth and stated.

It is now necessary to reproduce on the desired part or parts of the surfaces of the moulds,

80

85

90

95

100

105

110

115

120

125

130

135

140

145

150

presses, dies, or casting forms that come into contact with the desired surfaces of the product to be made from the non-grained fibrous mass permanent, exact, minute, clear, detailed reproductions of the natural surface finishes of an inside layer of a mass of manufactured tobacco, or any other desired types or design of finishes. One method of doing this is to take an exact proper impression of the desired finish of the inside layer of pressed tobacco and from this impression make moulds, by well known methods, with this desired exact impression showing on the desired part or parts of the surfaces of these moulds that come into contact with the desired part or parts of the surfaces of the non-grained fibrous mass which it is desired to have made into the finished product. Then when this finished product is taken from the moulds it will have, as a permanent, integral, finish on that desired part or parts of its surface or surfaces, an exact reproduction of this desired finish. The term "moulds" is used to cover and include presses, dies, casting forms, and any method of properly fashioning the non-grained fibrous mass into the desired finished product. The term "desired finish" is used to cover and include any desired finish and the natural finish of an inside layer of a mass of manufactured tobacco.

Some of the objects of my invention having been stated other objects will appear as the description proceeds, when taken in connection with the accompanying drawing, in which—

Figure 1 is a side elevation of a tobacco press built in accordance with my invention;

Figure 2 is a face view of one of the members 19 in Figure 1;

Figure 3 is a side elevation partly in cross-section of a caddy of tobacco equipped with a special head member;

Figure 4 is a face view of the special head member for the caddy shown in Figure 3.

Referring more specifically to the drawing the numerals 10 and 11 indicate the supporting members for my conventional press frame which members 10 and 11 have the projections 12 and 13 thereon which are adapted to support the press proper which is indicated by the reference character 14 which press has projections 15 and 16 thereon, which are adapted to normally rest on projections 12 and 13.

The press is equipped with the head members 17 and 18 and all of the structure thus far described is a conventional press. I provide the contacting surfaces of the head members 17 and 18 with a special plate member 19. Heretofore the surface of the press heads 17 and 18 which contact with the tobacco have been slick and smooth and have imparted to the tobacco the unnatural or smooth finish which has heretofore been spoken of. In carrying out my invention by applying the same to a press I provide the press heads 17 and 18 with an integral, attached, or detachable member 19 which has on its surface contacting with the mass of tobacco 21 to be pressed a reproduction of the natural rough and ready finish of a layer of pressed plugs or pieces of tobacco taken from the interior of a batch of pressed manufactured tobacco. These members 19 have these irregular surfaces 20 thereon, on which appears the simulation or exact reproduction of the surface of a layer of tobacco taken from the inside of a batch of pressed plugs of tobacco. This surface is indicated by the reference character 20 in Figure 2 and these press

head surfaces 20 can be made by first taking an impression from a layer of pressed manufactured tobacco taken from the interior of the batch of pressed tobacco and from this impression the press head or the members 19 can be specially cast or impressed, simulating the interior of a batch of pressed plugs of tobacco. It is evident of course that any other desired design such as a trade-mark or other matter can be associated with the surface of the press head or the member 19 if desired.

After the tobacco which is indicated by the reference character 21 has been pressed in the press it is removed therefrom and placed into a caddy 22 which caddy instead of having the ordinary wooden head member is provided with a special head member composed of composition non-resilient material which heads are designated by the reference characters 23 and 24, and these members 23 and 24, made of macerated, ground up or otherwise prepared material which is pressed or otherwise prepared as heretofore described, and has the inside surfaces thereof which contact with the mass of tobacco embossed, stamped, moulded or otherwise provided with the actual reproduction of a layer of pressed plugs of manufactured tobacco taken from the interior of a batch of plugs of tobacco, said surface being represented by the reference character 25 in Figure 4. The tobacco after being pressed in the structure shown in Figure 1 is then placed in the caddy as shown in Figure 3, under pressure, and the back pressure which has heretofore been spoken of then exerts itself for an appreciable length of time after the tobacco 21 is confined within the caddy, and although the tobacco 21 is provided with a surface 20 while in the press proper it will also contact with the other surface 25, so as to cause the tobacco to receive the additional impression of the surface 25 so that in case there should be any portion of the surface of the batch of tobacco which is not properly impressed by the first press that the continued pressure exerted by the back pressure after the tobacco has been sealed in the caddy will cause the outside surfaces of the outside layers of tobacco to be moulded with an exact reproduction of a layer taken from the inside of a batch of pressed manufactured tobacco.

It is therefore evident that I have provided means for pressing tobacco with a natural rough and ready finish and confining said tobacco in a caddy with head members also provided with the contacting surfaces moulded or otherwise provided with a surface which is a reproduction of a layer of pressed tobacco taken from the interior of a batch of pressed manufactured tobacco.

Should the mass of tobacco 21 be pressed in a press with the present used conventional type of slick top and bottom press members and then placed in a caddy or container 22 with top and bottom head members 23 and 24 and sufficient pressure be used in pressing into place and fastening the caddy or container head member and, also, sufficient back pressure be exerted by the mass of tobacco 21 on the members 23 and 24, when confined in the caddy or container 23, the outside surface of the mass of tobacco contacting with the members 23 and 24 will have imparted to such outside surfaces natural surfaces exactly like the surfaces of a layer of tobacco taken from the interior of a batch of pressed manufactured tobacco.

The members 19 are preferably made of an expansible material so that when used in presses

they will expand against the sidewalls of the
 press and prevent squirting or spewing as now
 occurs when metallic plates are used. If desired
 I can have the members now expansible and rigid
 5 so said plate members 19 can be used for heads
 and bottoms for the container in which the to-
 bacco is packed instead of the members 23 and 24.

In the drawing and specification I have set
 forth a preferred embodiment of my invention,
 10 and although specific terms are employed, they
 are used in a generic and descriptive sense only,
 and not for purposes of limitation, the scope of
 the invention being set forth in the appended
 claim.

I claim:

That method of pressing and packing pieces of

manufactured tobacco which comprises placing
 a batch of pieces of tobacco in a suitable press
 and impressing on the surfaces which are to
 occupy the top and bottom positions in a packing
 caddy or box a surface which is a reproduction
 of the surface finish of a layer of tobacco taken
 80 from an inside layer of pressed manufactured
 tobacco, then removing the batch of pressed to-
 bacco from the press and sealing the same in a
 caddy, box, and the like and while in the caddy,
 85 box, and the like again impressing on the top and
 bottom surfaces of the batch of tobacco another
 surface finish which is a reproduction of a layer
 of tobacco taken from the inside of a batch of
 pressed manufactured tobacco.

HENRY P. TAYLOR.

20

95

25

100

30

105

35

110

40

115

45

120

50

125

55

130

60

135

65

140

70

145

75

150