



US006212041B1

(12) **United States Patent**
Ohwe et al.

(10) **Patent No.:** **US 6,212,041 B1**
(45) **Date of Patent:** ***Apr. 3, 2001**

(54) **MAGNETIC HEAD SUPPORTING MECHANISM**

5,422,764 6/1995 McIvemie 360/106

FOREIGN PATENT DOCUMENTS

(75) Inventors: **Takeshi Ohwe; Yoshifumi Mizoshita,**
both of Kawasaki (JP)

- 0484906 5/1992 (EP) .
- 487 914 6/1992 (EP) .
- 53-30310 3/1978 (JP) .
- 59-60761 4/1984 (JP) .
- 60-246015 12/1985 (JP) .
- 63-83908 4/1988 (JP) .
- 1-128 277 5/1989 (JP) .
- 2-227813 9/1990 (JP) .
- 3-189976 8/1991 (JP) .
- 4162271 6/1992 (JP) .
- 5166159 7/1993 (JP) .
- 6124558 5/1994 (JP) .
- 92-20066 11/1992 (WO) .

(73) Assignee: **Fujitsu Limited,** Kawasaki (JP)

(*) Notice: This patent issued on a continued prosecution application filed under 37 CFR 1.53(d), and is subject to the twenty year patent term provisions of 35 U.S.C. 154(a)(2).

Subject to any disclaimer, the term of this patent is extended or adjusted under 35 U.S.C. 154(b) by 0 days.

OTHER PUBLICATIONS

Hutchinson Technology, Type 16 Suspension Product Summary, Jul. 15, 1991.
 Patent Abstracts of Japan, vol. 14, No. 160, Mar. 28, 1990.
 Patent Abstracts of Japan, vol. 8, No. 192, Sep. 4, 1984.
 Patent Abstracts of Japan, vol. 10, No. 116 (P-452) Apr. 30, 1986 of JP-A-60 246015 (Nippon Denshin Denwa Kosha) Dec. 5, 1985.

(List continued on next page.)

Primary Examiner—Allen T. Cao

(74) *Attorney, Agent, or Firm*—Armstrong, Westerman, Hattori, McLeland & Naughton, LLP

(57) **ABSTRACT**

A magnetic head supporting mechanism includes a head positioning actuator having an arm, and a load beam connected to the arm. The load beam has a gimbal. The gimbal includes a magnetic head slider fixing portion on which a magnetic head slider having a magnetic head is mounted, a first pair of beams extending from opposite sides of the magnetic head slider fixing portion along a traverse direction of the load beam perpendicular to a longitudinal direction thereof, and a second pair of beams respectively connected to the first pair of beams and extending so as to face the opposite sides of the magnetic head slider fixing portion.

8 Claims, 25 Drawing Sheets

(21) Appl. No.: **09/362,704**

(22) Filed: **Jul. 29, 1999**

Related U.S. Application Data

(63) Continuation of application No. 08/475,181, filed on Jun. 7, 1995, now Pat. No. 6,002,548.

(30) **Foreign Application Priority Data**

Nov. 27, 1992 (JP) 4-318846
 Apr. 8, 1993 (JP) 5-082110

(51) **Int. Cl.**⁷ **G11B 5/60**

(52) **U.S. Cl.** **360/235.4**

(58) **Field of Search** 360/104-106,
360/235.4

(56) **References Cited**

U.S. PATENT DOCUMENTS

- 4,853,813 8/1989 Yamanouchi .
- 5,006,946 4/1991 Matsuzaki .
- 5,065,271 11/1991 Matsuura et al. .
- 5,198,945 3/1993 Blaeser et al. .
- 5,305,168 4/1994 Lin et al. .
- 5,331,489 7/1994 Johnson et al. 360/104
- 5,414,576 5/1995 Ueki et al. 360/104

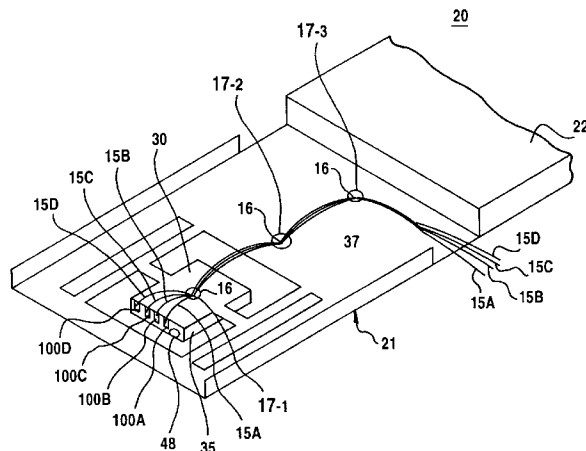

OTHER PUBLICATIONS

Patent Abstracts of Japan, vol. 10, No. 284 (P-501) Sep. 26, 1986 JP-A-61 104315 (Fujitsu Ltd.) May 22, 1986.

Patent Abstracts of Japan, vol. 2, No. 109 (E-056) Sep. 9, 1978 of JP-A-53 074414 (Matsushita Electric Ind. Co. Ltd.) Jul. 1, 1978.

Patent Abstracts of Japan, vol. 2, No. 064 (E-033) May 17, 1978 of JP-A-53 030310 (Fujitsu Ltd.) Mar. 22, 1978.

Patent Abstracts of Japan, vol. 3, No.077 (E-120) Jun. 30, 1979 of JP-A-54 054614 (NEC Corp.) May 1, 1979.

Patent Abstracts of Japan, vol. 14, No. 160 (P-1028) Mar. 28, 1990 of JP-A-02 015412 (Matsushita Electric Ind. Co. Ltd.) Jan. 19, 1990.

Patent Abstracts of Japan, vol. 14, No. 191 (P-1038) Apr. 18, 1990 of JP-A-02 035676 (NEC Corp.) Feb. 6, 1990.

Patent Abstracts of Japan, Vo. 15, No. 483 (P-1285) Dec. 6, 1991 of JP-A-03 209610 (Matsushita Electric Ind. Co. Ltd.) Sep. 12, 1991.

FIG. 1
PRIOR ART

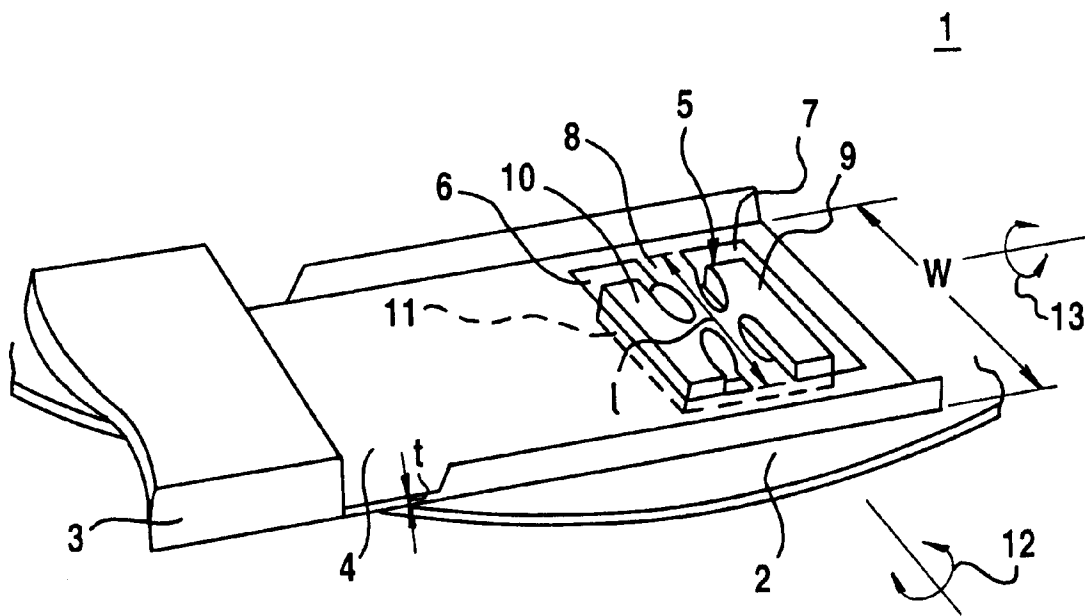

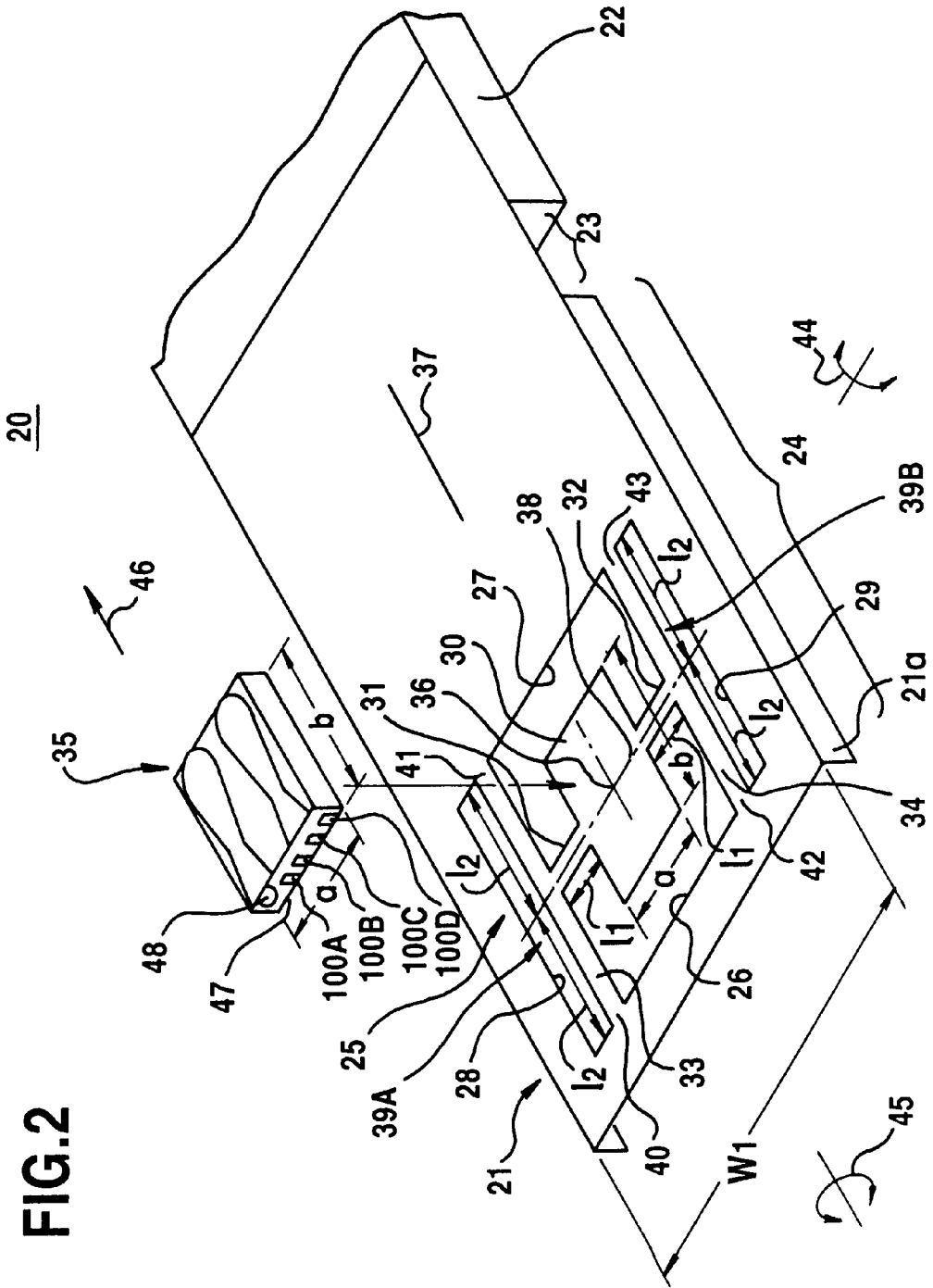

FIG. 2

FIG.3

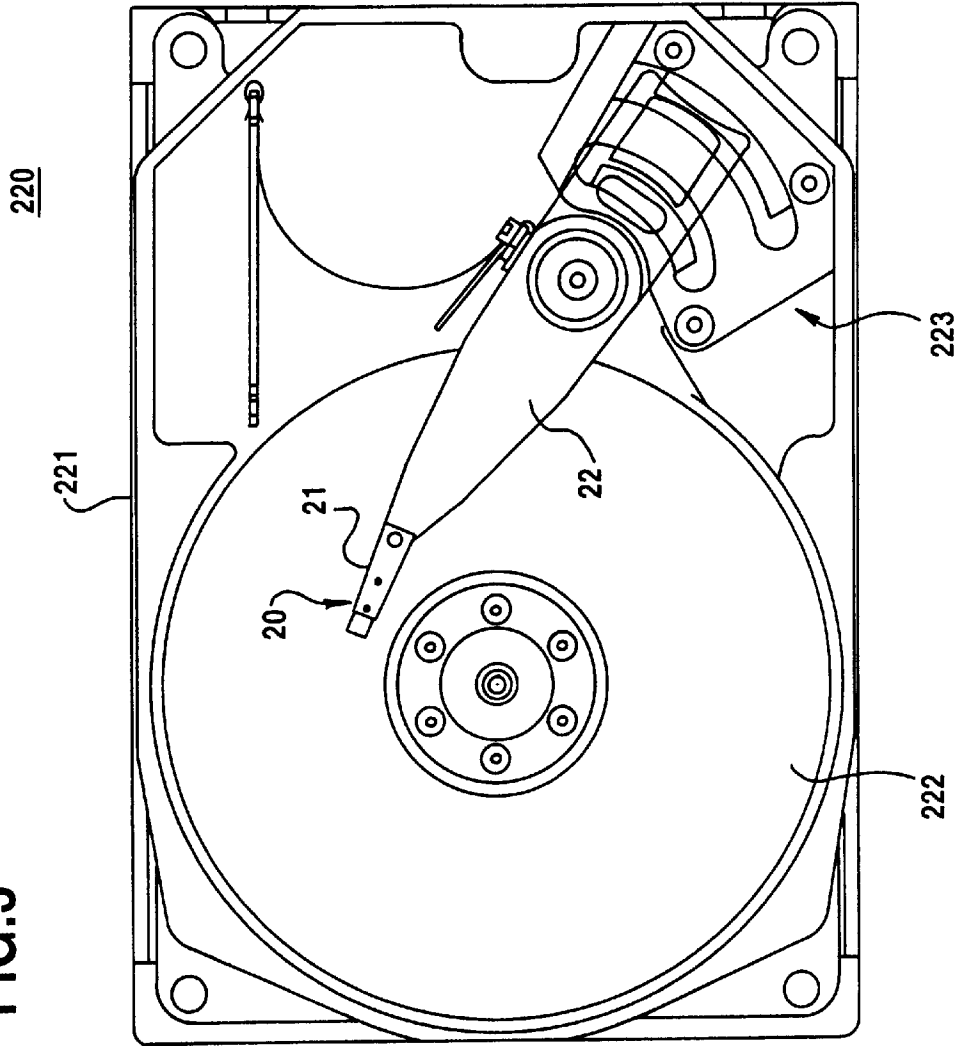

FIG.4

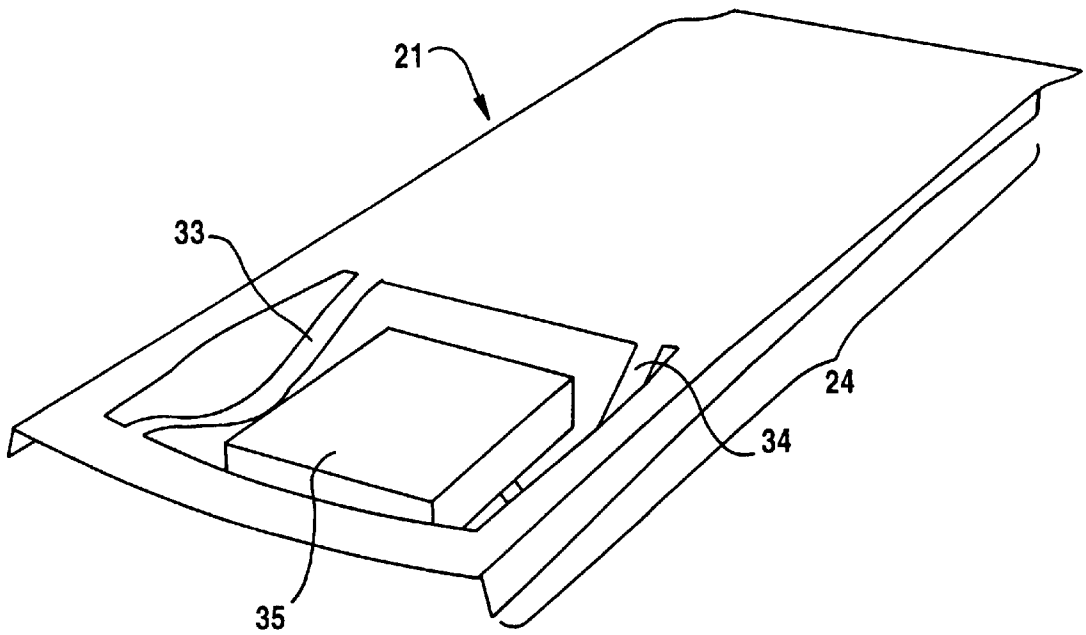
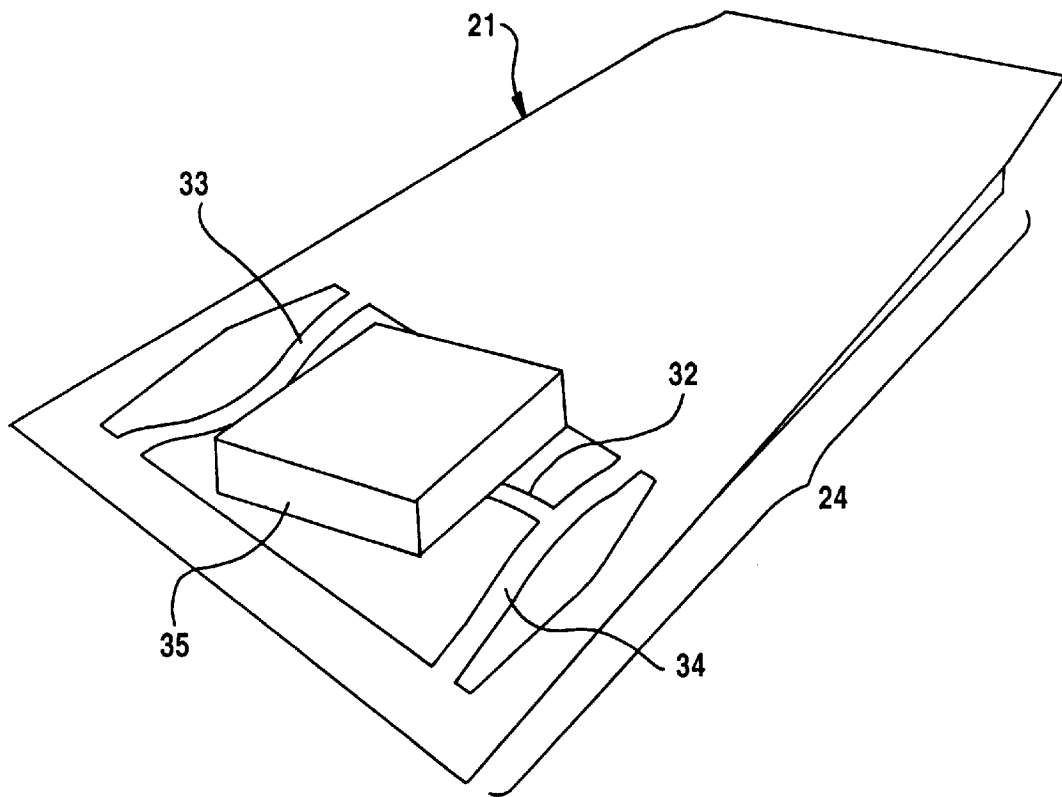

FIG.5



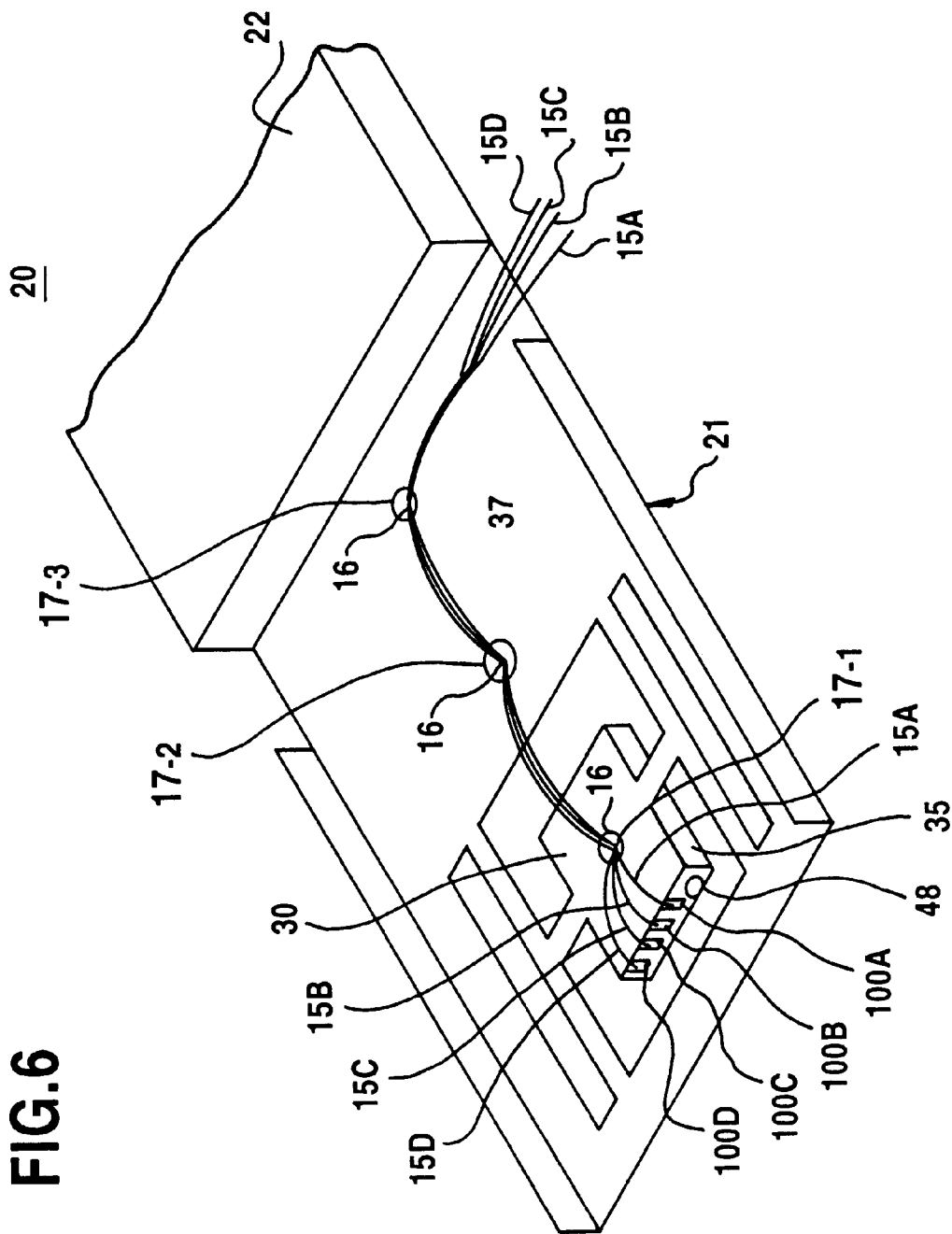

FIG. 6

FIG.7

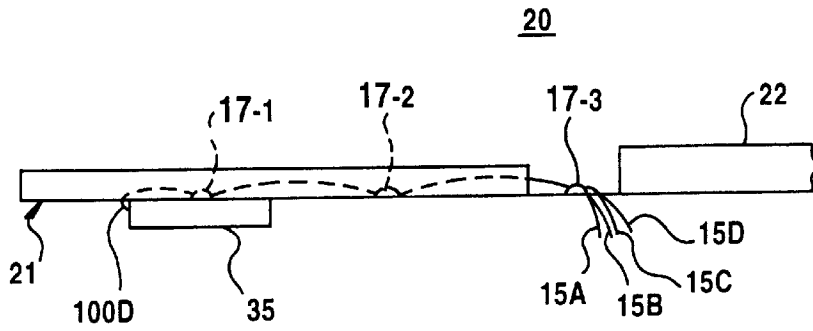

FIG.8

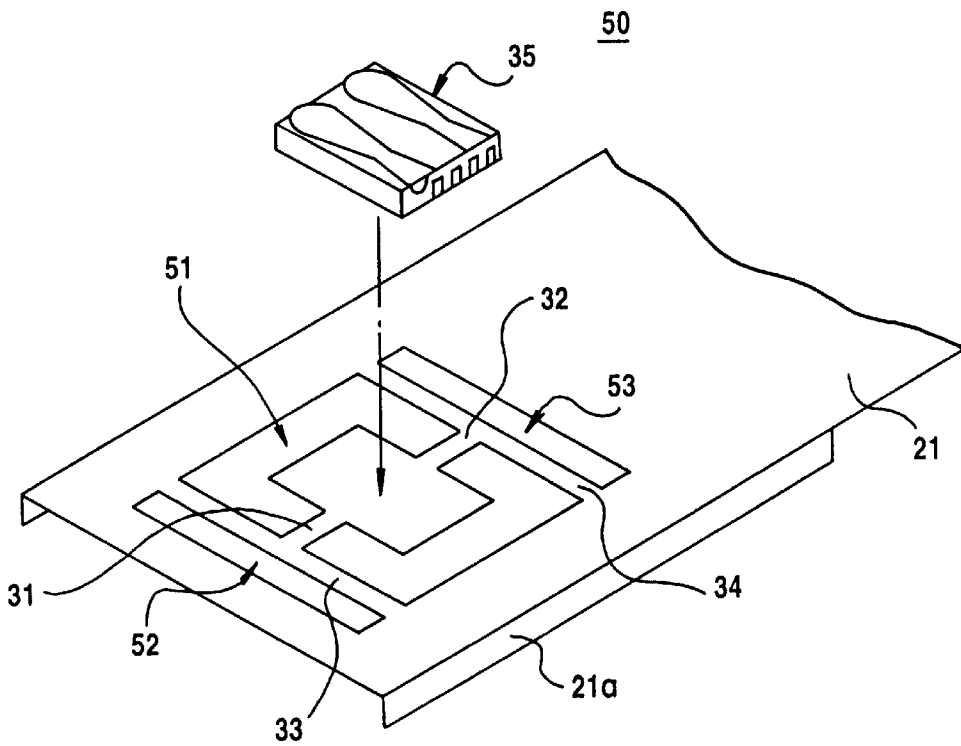
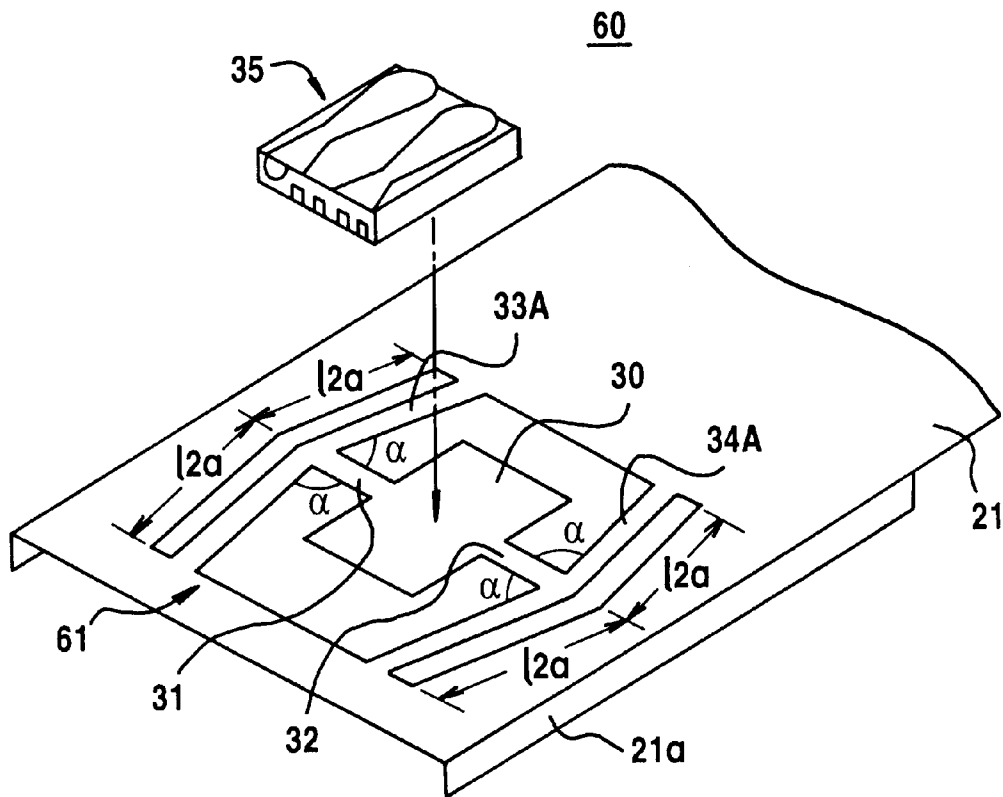

FIG.9



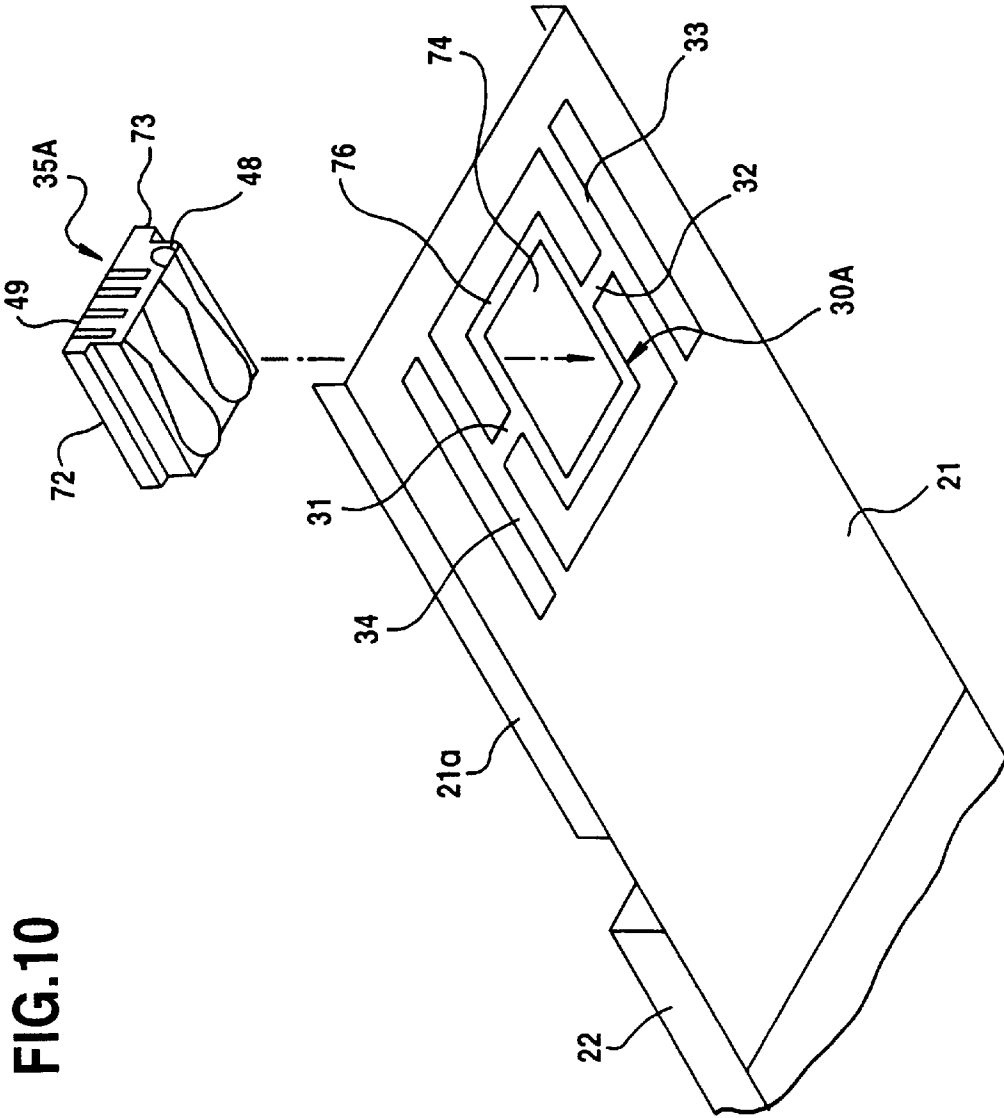

FIG.10

FIG. 13

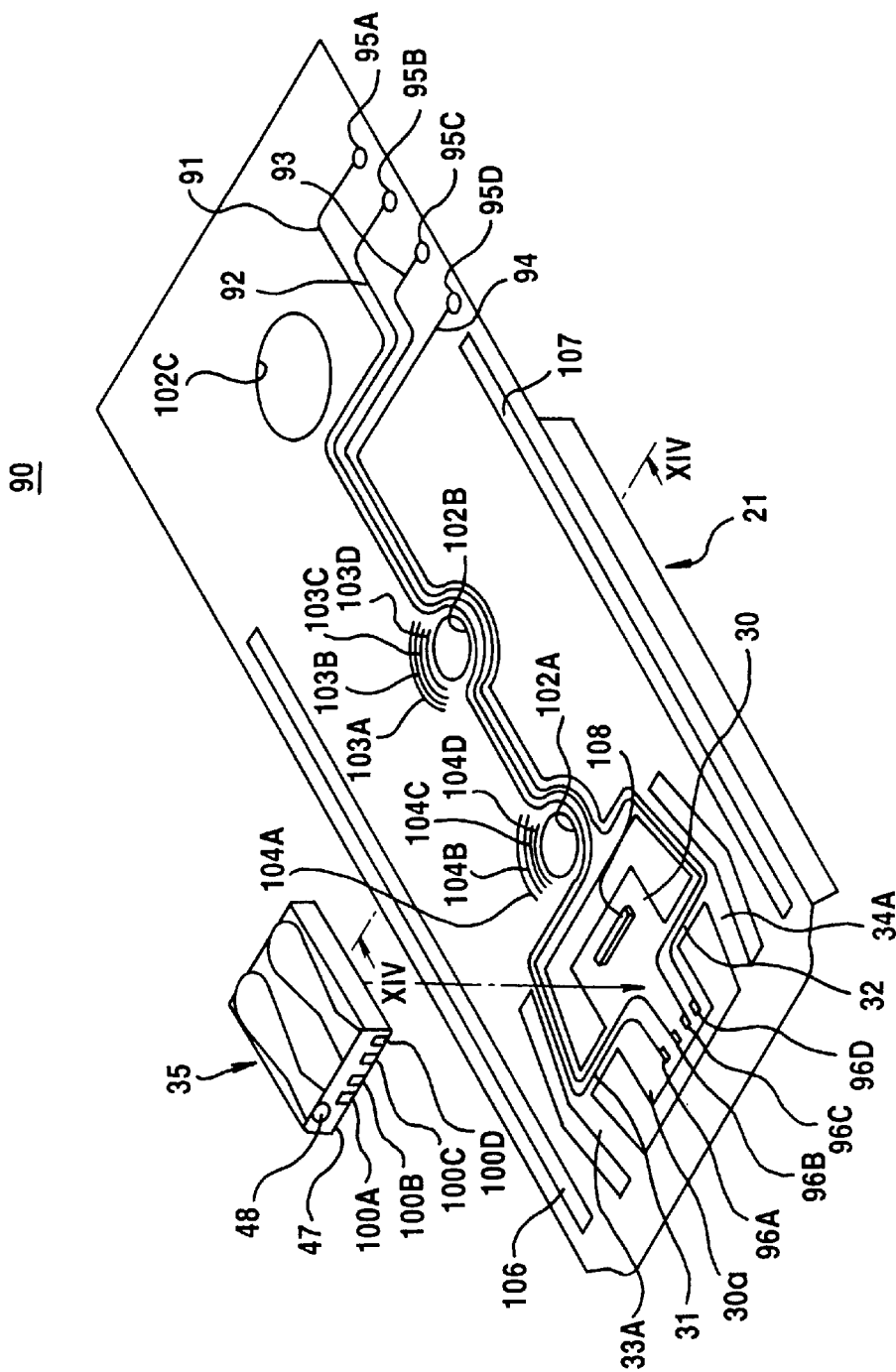

FIG.14

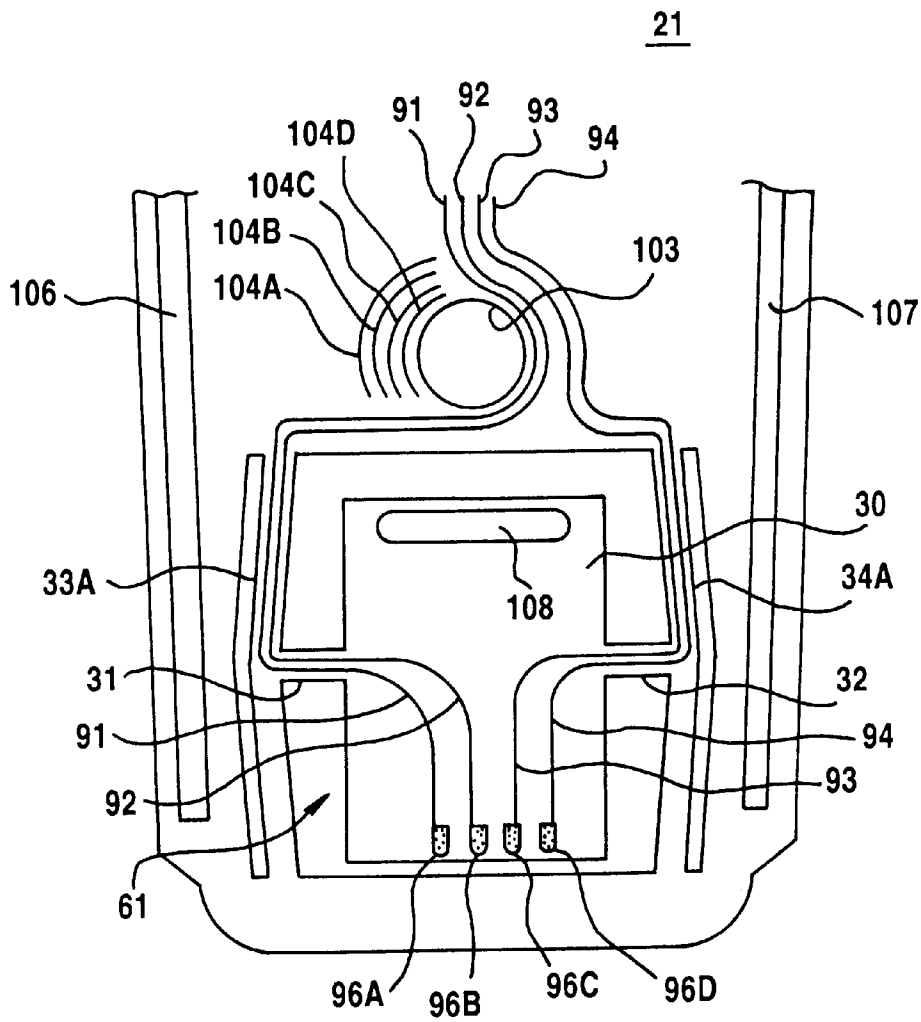

FIG. 15

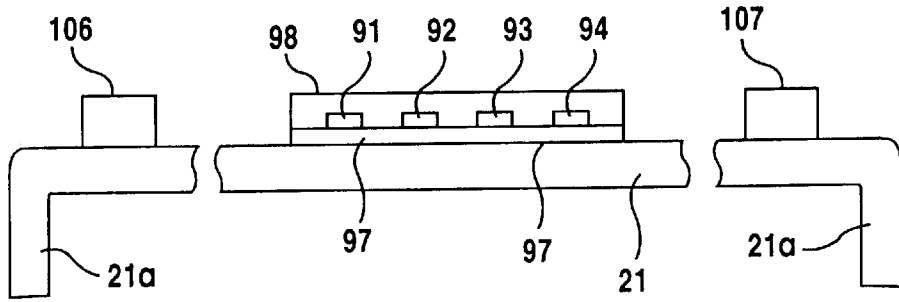

FIG. 16

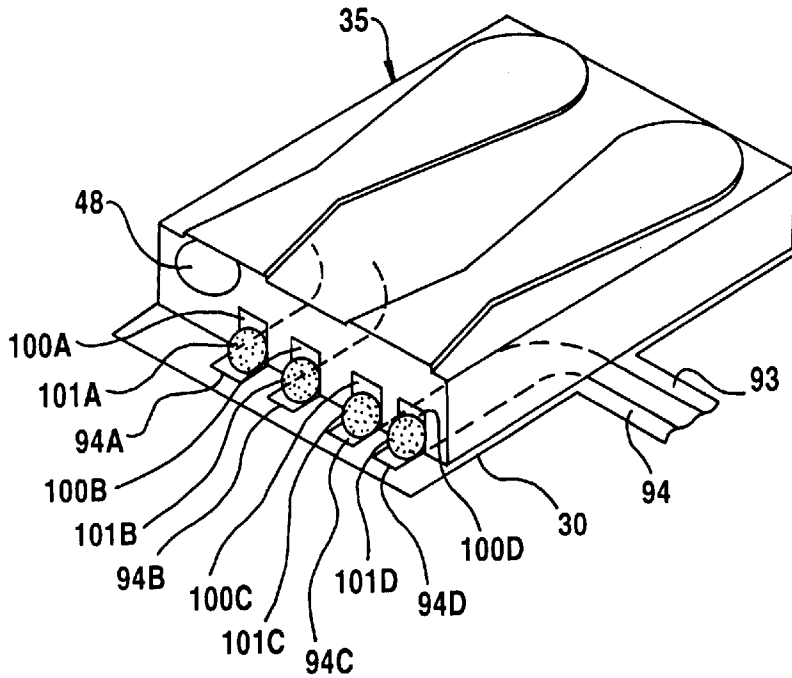

FIG.17

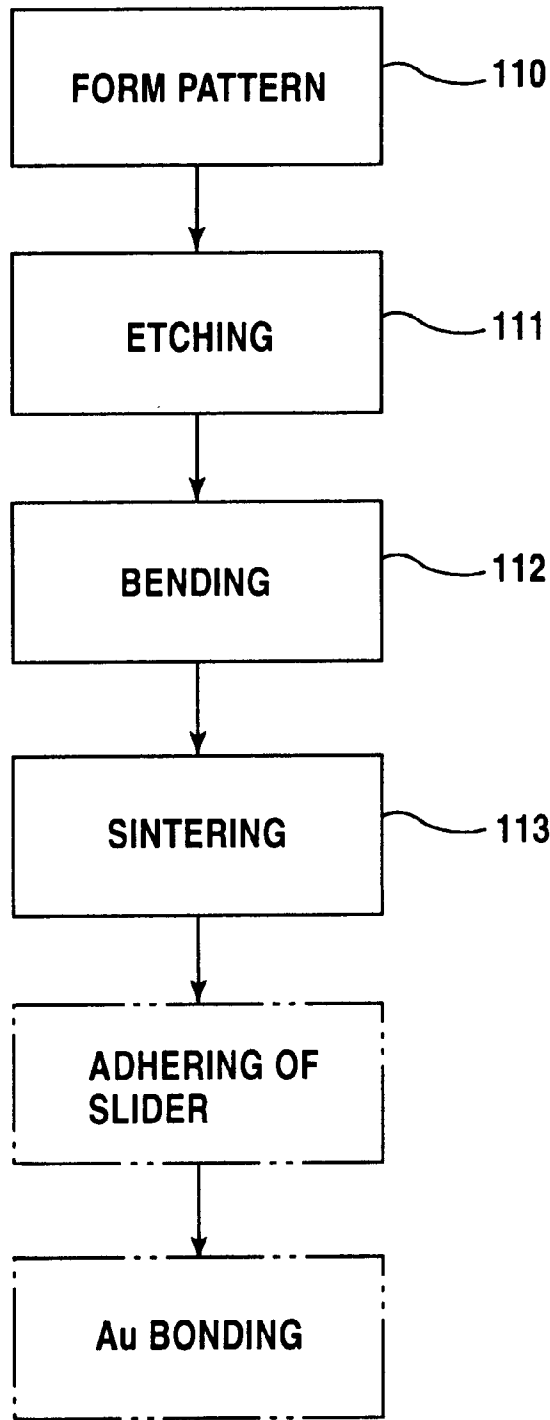

FIG. 18

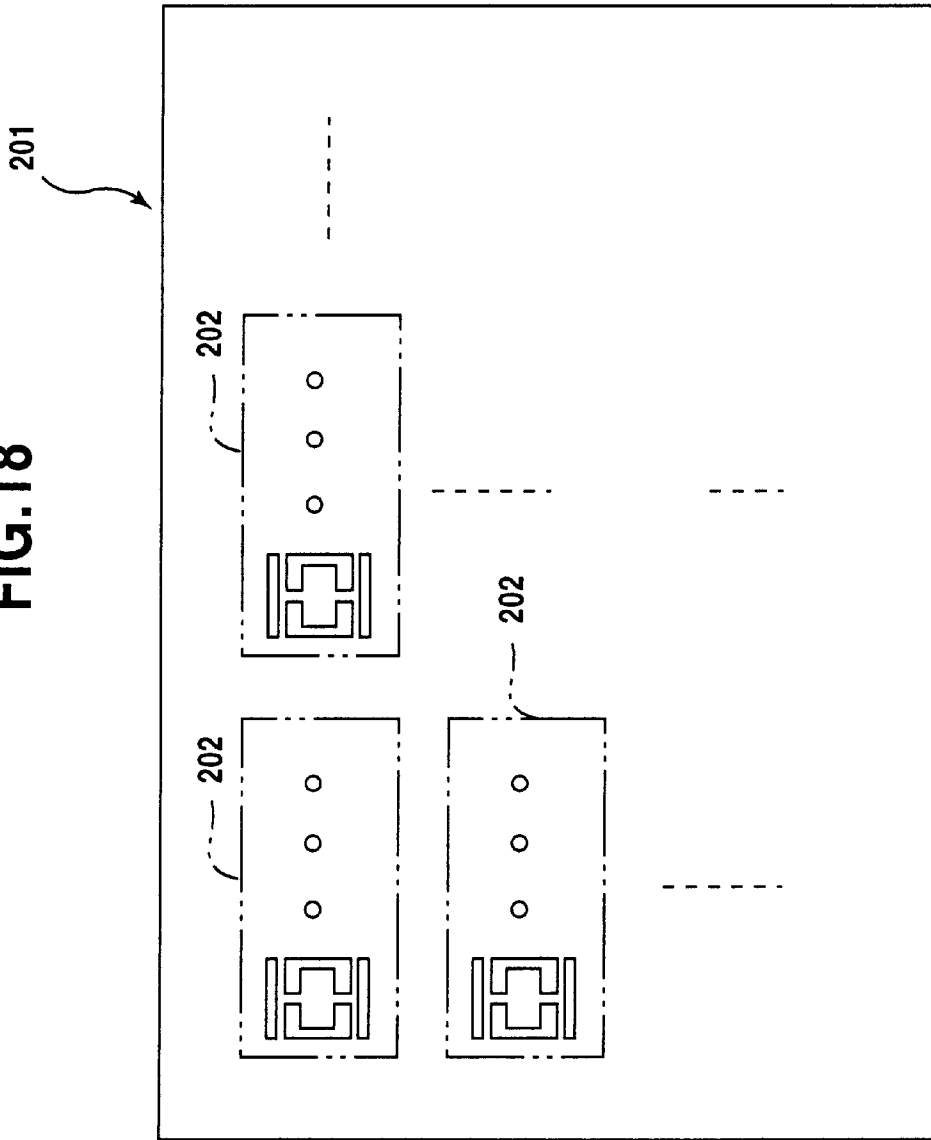

FIG.19

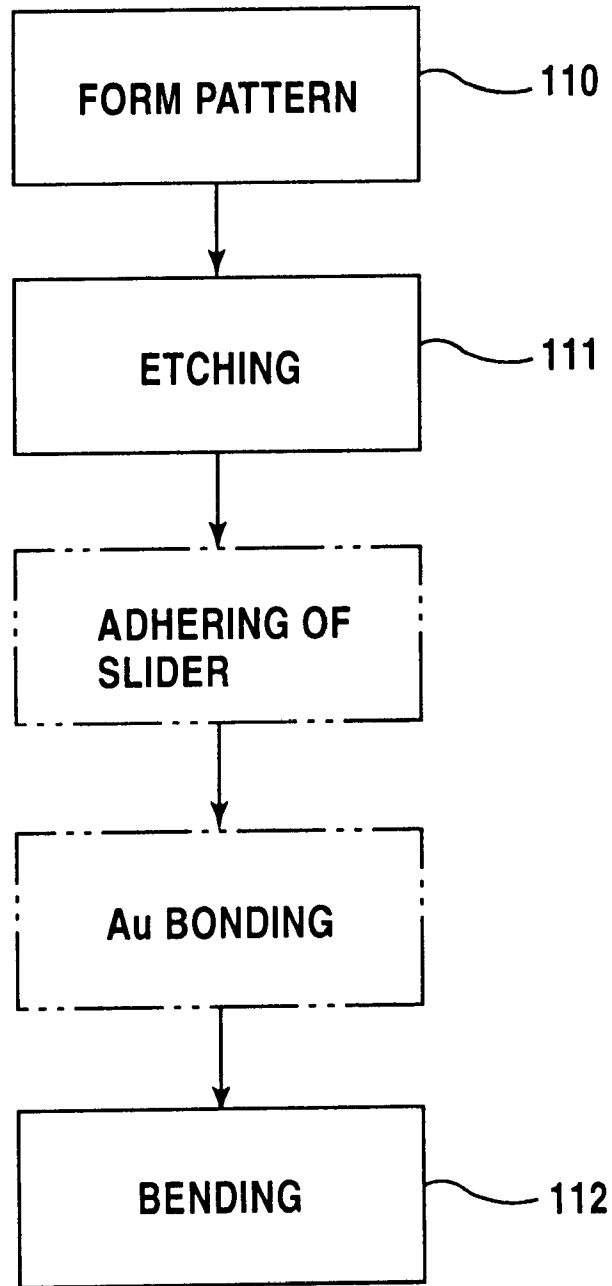

FIG.20

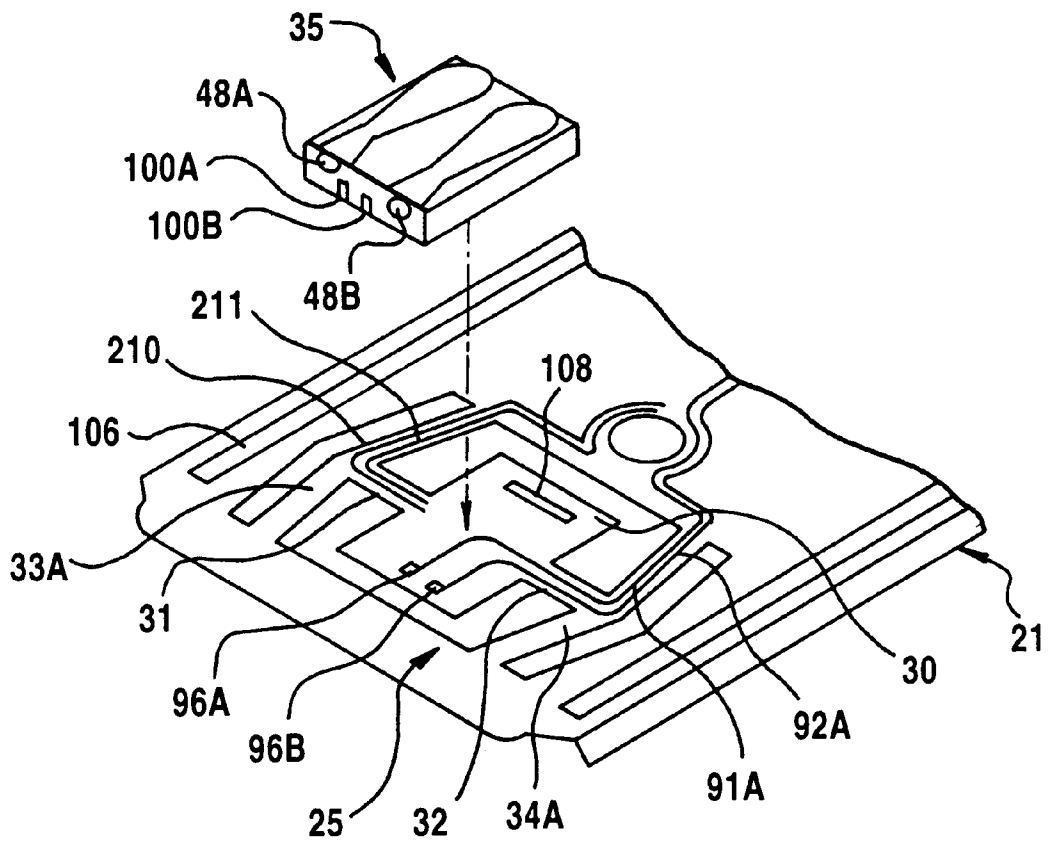

FIG. 21

230

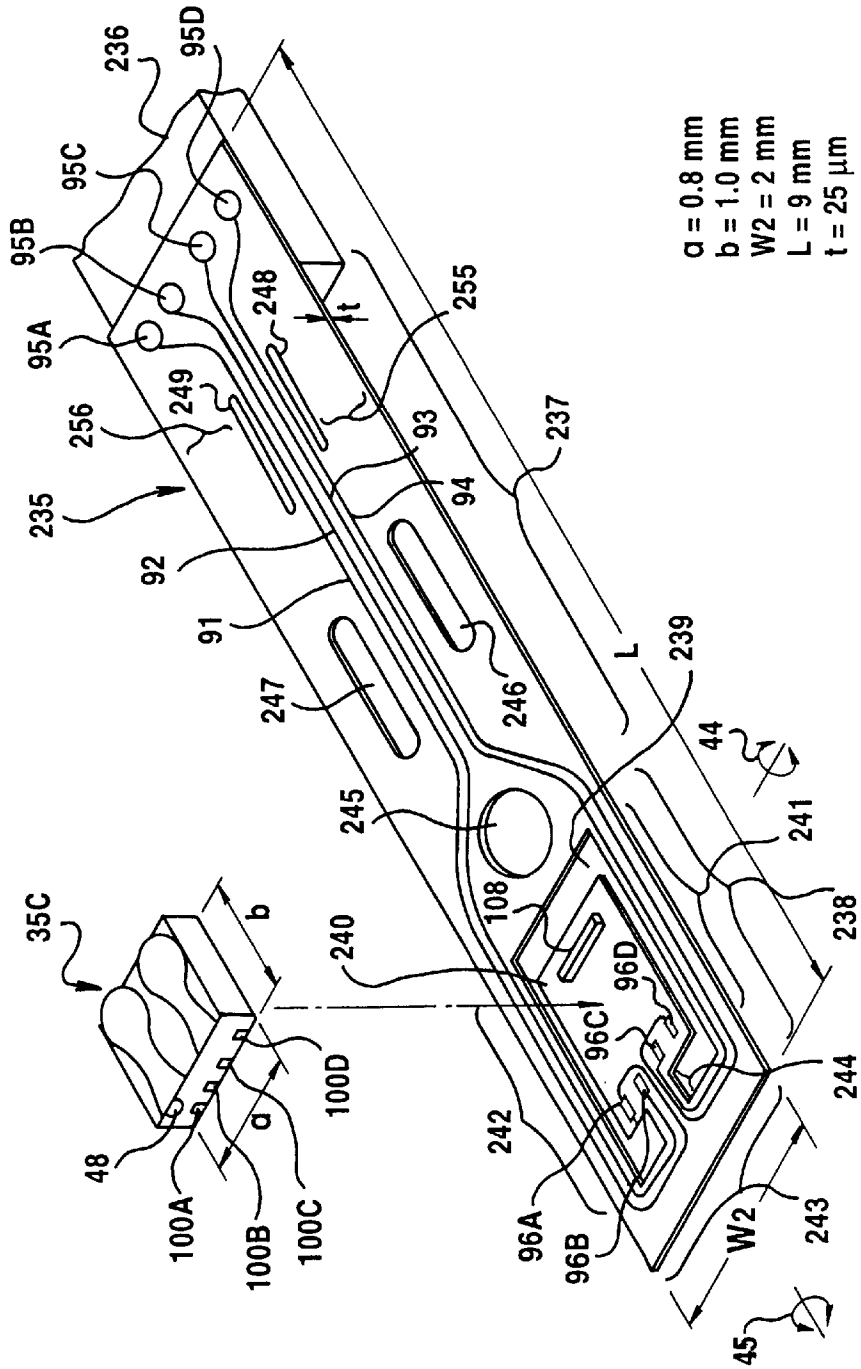

FIG.22

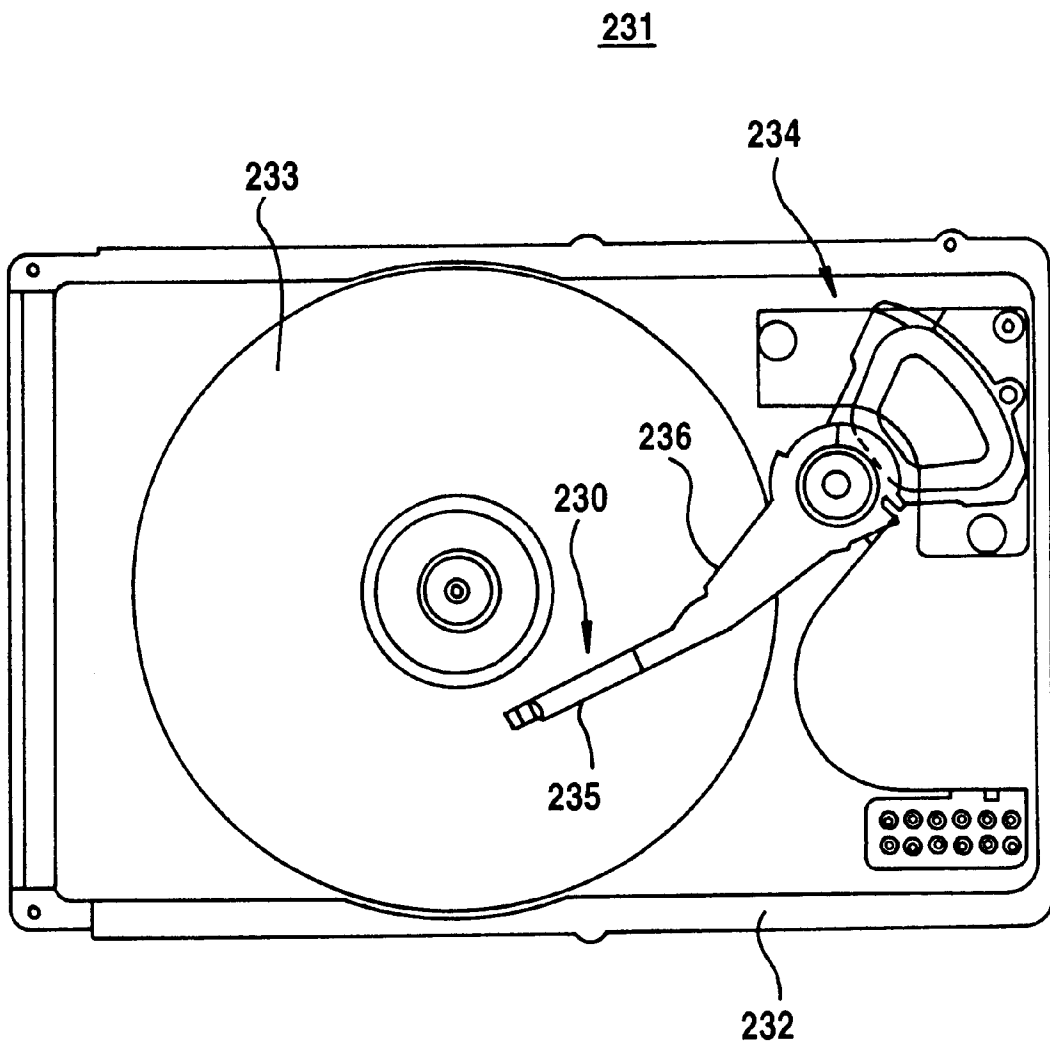

FIG.23A

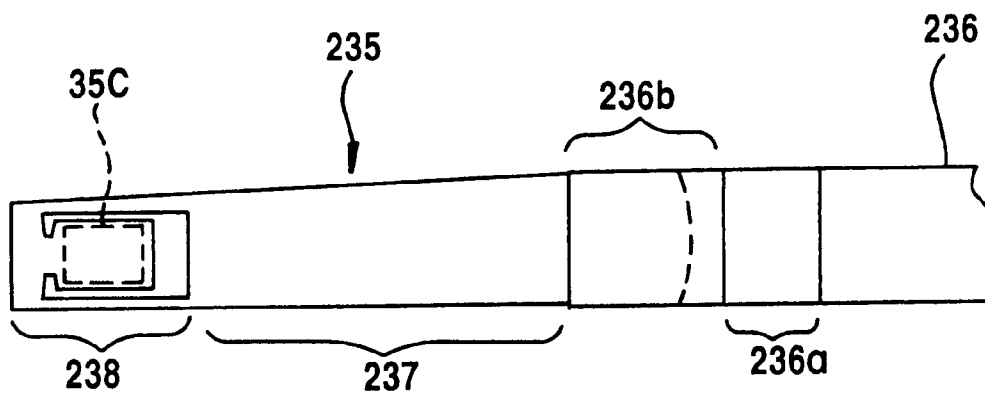

FIG.23B

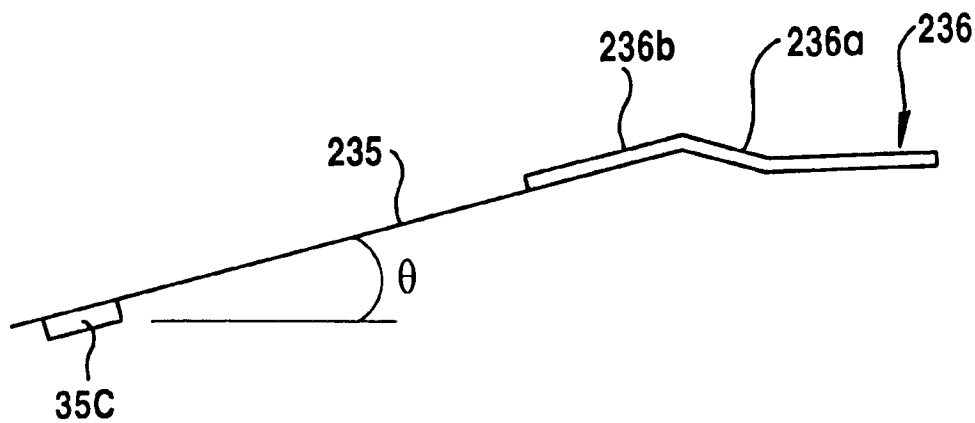

FIG.24

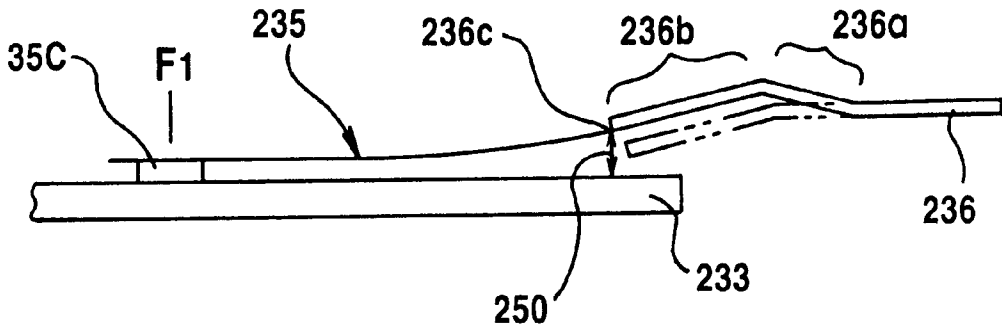

FIG.25

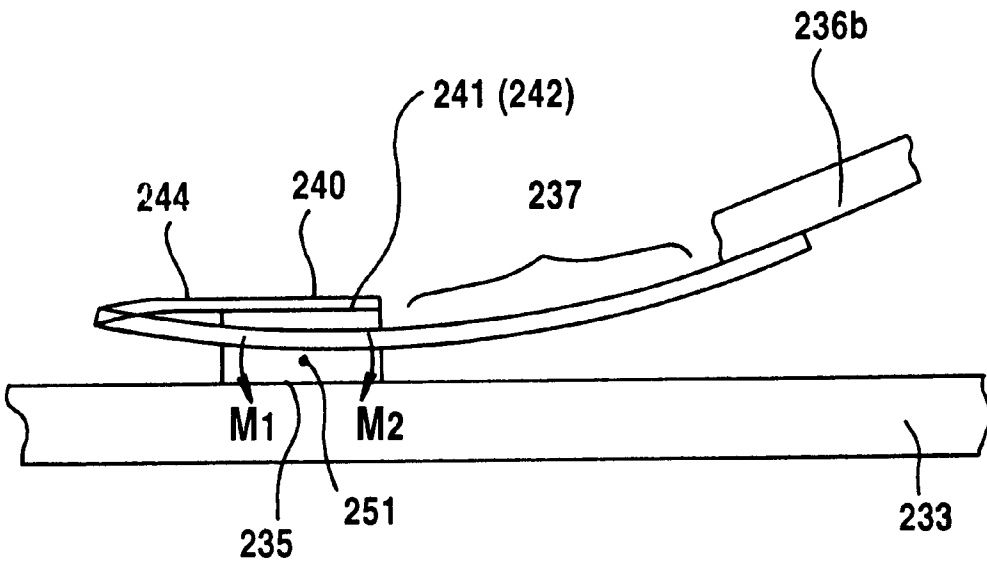

FIG.26

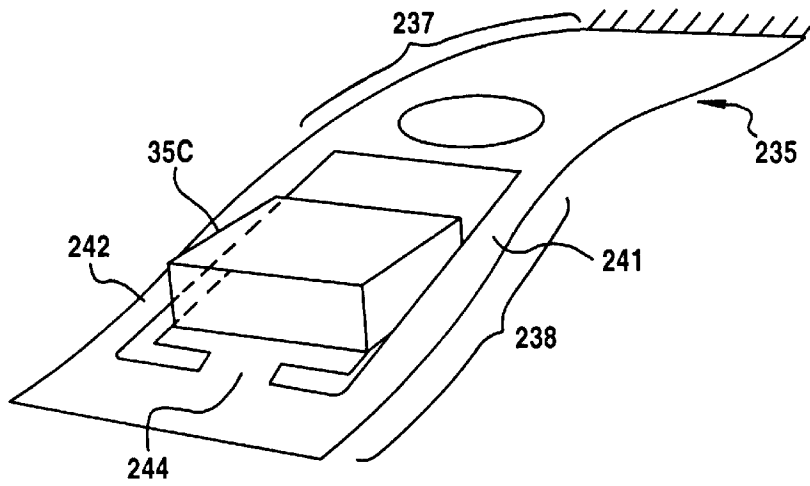

FIG.27

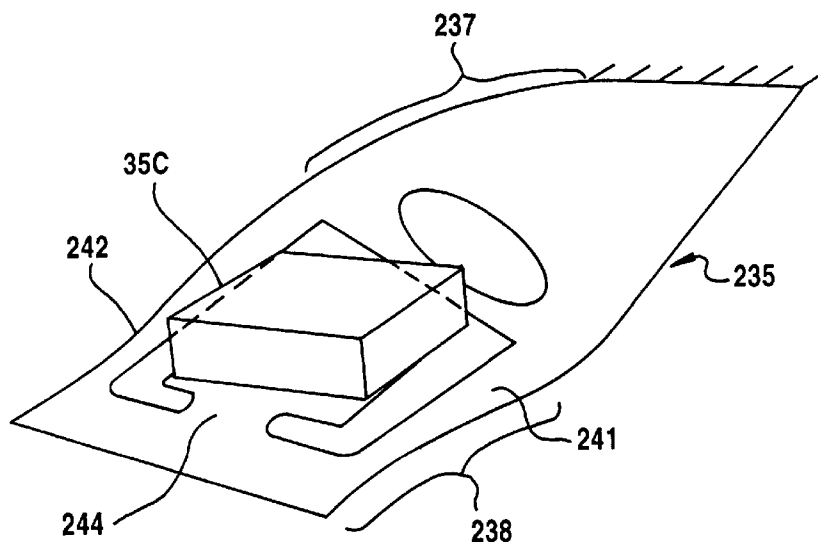

FIG.28

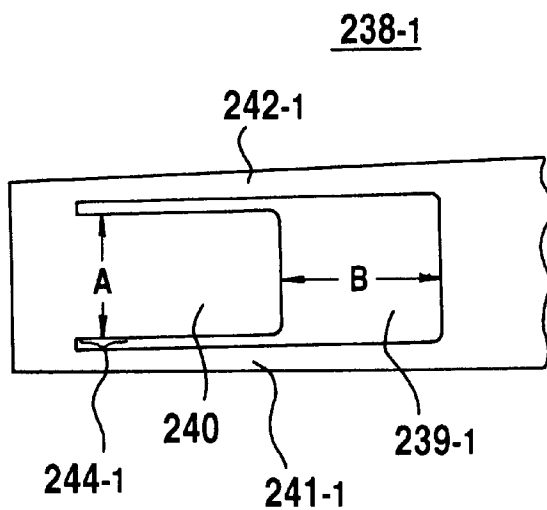

FIG.29

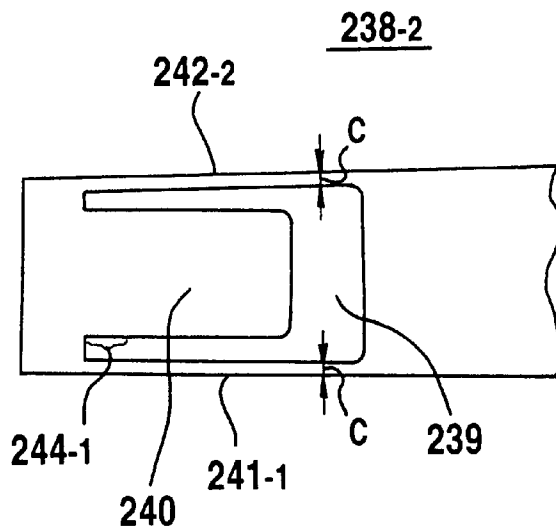

FIG.30

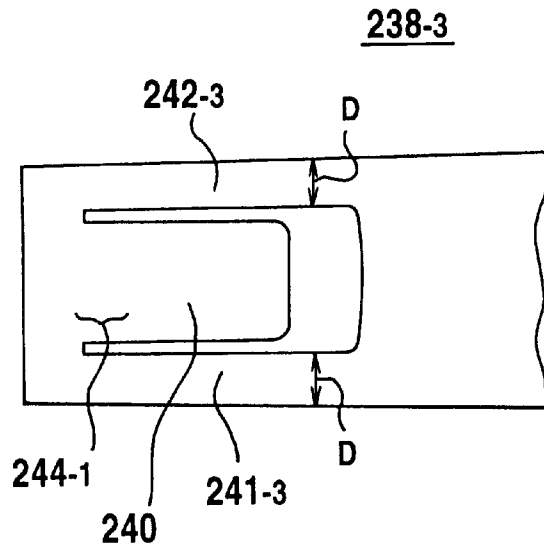

FIG.31

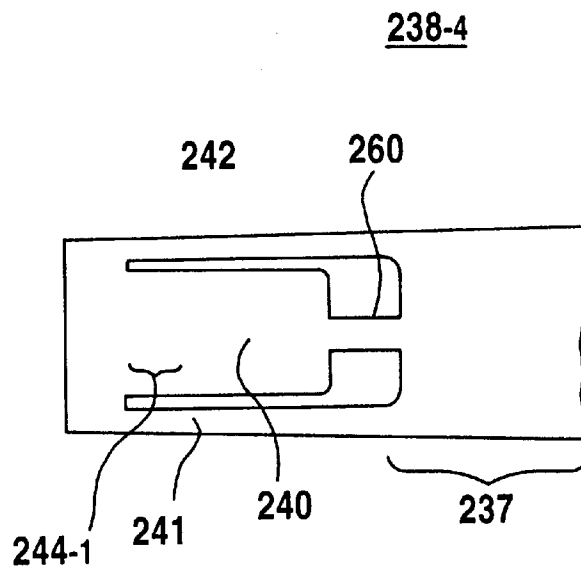

FIG.32

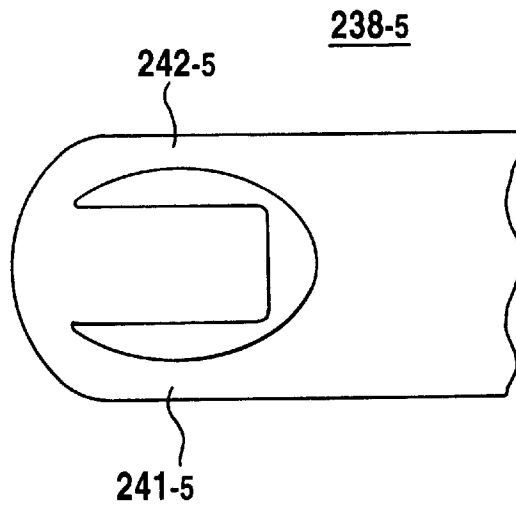
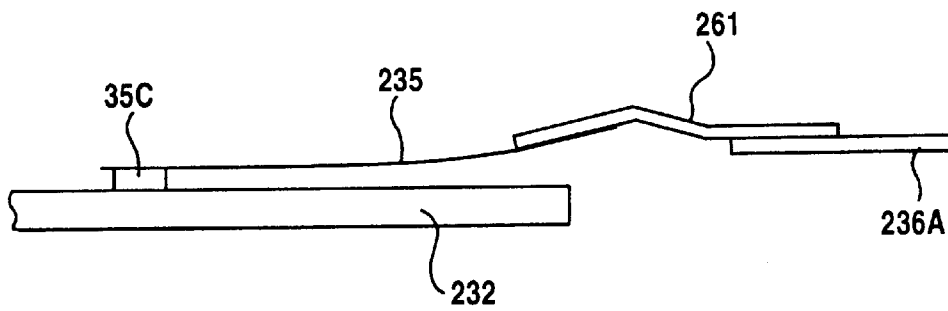

FIG.33



MAGNETIC HEAD SUPPORTING MECHANISM

This application is a continuation of prior application Ser. No. 08/475,181 filed Jun. 7, 1995 now U.S. Pat. No. 6,002,548.

BACKGROUND OF THE INVENTION

1. Field of the Invention

The present invention relates to a magnetic head supporting mechanism used for a magnetic disk drive.

2. Description of the Related Art

A magnetic head slider on which a magnetic head is mounted is attached to a free end of a load beam, and is maintained, during a recording/reproducing operation, in a state in which the magnetic head slider flies above a magnetic disk.

Recently, it has been required to improve an HDI (Head Disk Interface) characteristic, which is one of the parameters describing the reliability of magnetic disk drives. In order to meet the above requirement, it is necessary to diminish the mass of the magnetic head slider or reduce a spring force urging the magnetic head slider towards the magnetic disk.

The following event will occur when the mass of the magnetic head slider is diminished. It is necessary to reduce the size of a supporting spring which holds the magnetic head slider as the slider is reduced in size. This is intended to maintain the following characteristic with respect to waviness of the disk and maintain the flying stability of the head. The following event will occur when the spring force on the head slider is reduced. That is, the flying stiffness of the head is degraded due to reduction of the spring force on the head slider. Further, the possibility of assembly errors increases because parts, such as a slider and a supporting spring, are diminished in mass. With the above in mind, it is necessary for a device for supporting a magnetic head slider to have a mechanism capable of sufficiently ensuring the flying stability of the magnetic head slider.

Conventionally, the magnetic head supporting mechanism is made up of a load beam, a gimbal fixed to the load beam, and a magnetic head slider fixed to the gimbal. With the above structure, it is more difficult to assemble (position) these parts as the size of the parts is reduced. When there is an assembly error, the magnetic head slider is maintained in an unbalance flying state in which the slider flies in a tilted state. Hence, the reliability of the flying head is degraded and further the read/write characteristics are also degraded. As a result, the reliability of the magnetic disk drive is also degraded.

In order to eliminate the factors causing the unbalanced flying due to the assembly error of the head supporting mechanism, Japanese Patent Laid-Open Application No. 3-189976 proposes an improvement in which an integrally formed supporting spring corresponding to the conventional load beam and gimbal is used and assembly is no longer needed.

FIG. 1 shows a magnetic head supporting mechanism 1 disclosed in the above application document. The magnetic head supporting mechanism 1 includes a load arm 3 and a load beam 4 (which is also referred to as a flexure). The load beam 4 includes a gimbal 5, which has openings (through holes) 6 and 7 having a substantially C shape. Further, the gimbal 5 includes a beam 8 supported at both ends in a direction in which the beam 8 traverses the load beam 4, and tongue portions 9 and 10 extending from the beam 8. The

back surface of the magnetic head slider 11 is formed so that grooves are formed in the width direction of the load beam 4.

The magnetic head slider 11 can be rotated together with a twist of the beam 8 in a pitching direction indicated by an arrow 12, and can be rotated together with a bend of the beam 8 in a rolling direction indicated by an arrow 13.

It is necessary to reduce the rotation stiffness of the gimbal 5 in order to ensure the flying stability of the compact magnetic head slider. Further, it is impossible to reduce the thickness t of the gimbal 5 having the above structure because the load beam 4 needs to be stiff. In order to reduce the rotation stiffness of the gimbal 5 without reducing the thickness t of the load beam 4, it is necessary to lengthen the length l of the beam 8. If the load beam 4 and the gimbal 5 are made to have different thicknesses, it is necessary to a complex process in which only the gimbal 5 is half etched, while the load beam is not processed. However, it is very difficult to obtain a desired precision in thickness by the above process and to obtain desirable characteristics.

If the length l of the beam 8 is increased, the following disadvantages will occur. First, the resonance point (frequency) of vibration of the twist and bend of the beam 8 will greatly become lower, and it becomes likely that the degree of flying of the magnetic head slider 11 is varied. Second, the width W of the load beam 4 increases, and hence the resonance frequency of vibration of the load beam 4 itself will become lower. Thus, the flying magnetic head slider 11 becomes unstable.

Consequently, when the integrally formed supporting spring having the integrated load beam and gimbal is used, it is very difficult to realize a structure of the integrated supporting spring in which only the rotation stiffness is reduced without decreasing the resonance frequency of the gimbal.

It becomes impossible to neglect the influence of lead wires connected to the head because of degradation of the airbearing stiffness caused by down-sizing of the slider and reduction in the load force on the head slider. More particularly, the slider is affected by the stiffness of the lead wires and may cause the slider to fly in the tilt state. Particularly, when a magneto-resistive effect type head (MR head) is used as a reproduction head, such a head is combined with an interactive type head. Hence, four lead wires equal to twice the number of lead wires for the conventional recording/reproducing head are needed. Use of the four lead wires increases the influence of the stiffness of the lead wires. This degrades not only the reliability of the flying head but also the read/write characteristics. Hence, the magnetic disk drive does not have a satisfactory reliability.

SUMMARY OF THE INVENTION

It is a general object of the present invention to provide a magnetic head supporting mechanism in which the above disadvantages are eliminated.

A more specific object of the present invention is to provide a magnetic head supporting mechanism capable of stably maintaining a magnetic head slider in the flying state.

The above objects of the present invention are achieved by a magnetic head supporting mechanism comprising: a head positioning actuator (223) having an arm (22); and a load beam (21) connected to said arm. The load beam has a gimbal (25) comprising: a magnetic head slider fixing portion (30) on which a magnetic head slider (35) having a magnetic head is mounted; a first pair of beams (31, 32) extending from opposite sides of the magnetic head slider

fixing portion along a traverse direction (38) of the load beam perpendicular to a longitudinal direction (37) thereof; and a second pair of beams (33, 34) respectively connected to the first pair of beams and extending along said opposite sides of the magnetic head slider fixing portion.

In an alternative, the first pair of beams extends in the longitudinal direction, and the second pair of beams extends in the traverse direction.

The above objects of the present invention are also achieved by a magnetic head supporting mechanism comprising: a head positioning actuator (223) having an arm (22); and a load beam (21) connected to said arm. The load beam having a gimbal (51) comprises: a magnetic head slider fixing portion (30) on which a magnetic head slider (35) having a magnetic head is mounted; a first pair of beams (31, 32) extending from opposite sides of the magnetic head slider fixing portion along a longitudinal direction of the load beam perpendicular to a traverse direction thereof; and a second pair of beams (33, 34) respectively connected to the first pair of beams and extending along said opposite sides of the magnetic head slider fixing portion.

Another object of the present invention is to provide a magnetic disk drive having the above-mentioned magnetic head supporting mechanism.

BRIEF DESCRIPTION OF THE DRAWINGS

Other objects, features and advantages of the present invention will become more apparent from the following detailed description when read in conjunction with the accompanying drawings, in which:

FIG. 1 is a perspective view of a conventional magnetic head supporting mechanism;

FIG. 2 is a perspective view of a magnetic head supporting mechanism according to a first embodiment of the present invention;

FIG. 3 is a plan view of a 3.5-inch magnetic disk drive to which the magnetic head supporting mechanism shown in FIG. 2 is applied;

FIG. 4 is a perspective view of a first-order bend state of a load beam shown in FIG. 2;

FIG. 5 is a perspective view of a first-order twist state of the load beam shown in FIG. 2;

FIG. 6 is a perspective view of the upper side of the magnetic head supporting mechanism shown in FIG. 2;

FIG. 7 is a side view of the magnetic head supporting mechanism shown in FIG. 2;

FIG. 8 is a perspective view of a magnetic head supporting mechanism according to a second embodiment of the present invention;

FIG. 9 is a perspective view of a magnetic head supporting mechanism according to a third embodiment of the present invention;

FIG. 10 is a perspective view of a magnetic head supporting mechanism according to a fourth embodiment of the present invention;

FIG. 11 is a side view of the mechanism shown in FIG. 10;

FIG. 12 is a perspective view of a magnetic head supporting mechanism according to a fifth embodiment of the present invention;

FIG. 13 is a perspective view of a magnetic head supporting mechanism according to a sixth embodiment of the present invention;

FIG. 14 is a plan view of a free-end part of a load beam shown in FIG. 13;

FIG. 15 is a sectional-view taken along a line XIV—XIV shown in FIG. 13;

FIG. 16 is a perspective view of a magnetic head slider shown in FIG. 13;

FIG. 17 is a flowchart of a production process for the load beam shown in FIG. 13;

FIG. 18 is a plan view of a plate obtained after an etching step shown in FIG. 17 is carried out;

FIG. 19 is a flowchart of another production process for the load beam shown in FIG. 13;

FIG. 20 is a perspective view of a variation of the sixth embodiment of the present invention;

FIG. 21 is a perspective view of a magnetic head supporting mechanism according to a seventh embodiment of the present invention;

FIG. 22 is a plan view of a magnetic disk drive to which the magnetic head supporting mechanism shown in FIG. 21 is applied;

FIGS. 23A and 23B are respectively plan and side views of the magnetic head supporting mechanism shown in FIG. 21;

FIG. 24 is a side view of a state observed when the magnetic head supporting mechanism shown in FIG. 21 is provided in the magnetic disk drive;

FIG. 25 is an emphasized view of the state in FIG. 24;

FIG. 26 is a side view of a first-order bend state of a load beam used in the seventh embodiment of the present invention;

FIG. 27 is a side view of a first-order twist state of the load beam used in the seventh embodiment of the present invention;

FIG. 28 is a plan view of a first variation of a gimbal of the load beam used in the seventh embodiment of the present invention;

FIG. 29 is a plan view of a second variation of the gimbal of the load beam used in the seventh embodiment of the present invention;

FIG. 30 is a plan view of a third variation of the gimbal of the load beam used in the seventh embodiment of the present invention;

FIG. 31 is a plan view of a fourth variation of the gimbal of the load beam used in the seventh embodiment of the present invention;

FIG. 32 is a plan view of a fifth variation of the gimbal of the load beam used in the seventh embodiment of the present invention; and

FIG. 33 is a side view of a variation of the seventh embodiment of the present invention.

DESCRIPTION OF THE PREFERRED EMBODIMENTS

A description will now be given, with reference to FIG. 2, of a magnetic head supporting mechanism 20 according to a first embodiment of the present invention.

FIG. 3 shows a 3.5-inch type magnetic disk drive 220 to which the magnetic head supporting mechanism 20 is applied. The magnetic disk drive 220 has an enclosure 221 in which a 3.5-inch magnetic disk 222, a head positioning actuator 223 and other parts are housed.

A load beam 21 made of stainless steel is fixed to an arm 22 of the actuator 223. The load beam 21 has a curved bent portion 23 generating elasticity. In this regard, the curved portion 23 of the load beam 21 is also referred to as an elastic

portion **23** in the following description. The load beam **21** has a stiffness portion **24** extending from the elastic portion **23**, and ribs **21a**. The elastic portion **23** provides a magnetic head slider **35** with a load in a direction in which the magnetic head slider **35** moves and comes into contact with a magnetic disk **222**. The load beam **21** has a uniform thickness of, for example, approximately $25\ \mu\text{m}$, which is equal to one-third of the thickness of a load beam of a 3380-type (IBM) head supporting mechanism.

It is desirable that the width **W1** of the load beam **21** is made as small as possible, desirably 4 mm or less. This is because the resonance frequency of vibration of the load beam **21** is prevented from lowering.

A gimbal **25** is formed in the load beam **21**. The gimbal **25** includes a pair of C-shaped openings **26** and **26** facing each other in the longitudinal direction of the load beam **21**. Two slits **28** and **29** are formed in the load beam **21** along respective sides of the load beam **21**.

The gimbal **25** includes a magnetic slider fixing portion **30**, a first pair of beam portions **31** and **32**, and a second pair of beam portions **33** and **34**. The magnetic head slider fixing portion **30** has large surface dimensions enough to fix the magnetic head slider **35** thereon, and has the same dimensions as the magnetic head slider **35** ($a=1.6\ \text{mm}$, $b=2.0\ \text{mm}$). However, it is possible for the slider fixing portion **30** to have an area less than the magnetic head slider **35** when a sufficient adhesive strength can be obtained.

The magnetic head slider **35** is a light weight structure type slider, which has been proposed in Japanese Patent Laid-Open Application No. 4-228157. The proposed slider has a flat back surface opposite to a disk facing surface. The flat back surface of the slider is fixed to the fixing portion **30** by means of an adhesive. In this case, the slider **35** is located so that the center thereof corresponds to the center of the fixing portion **30**. It is also possible to use other types of sliders.

The beam portions **31** and **32** extend outwardly from the respective sides of the fixing portion **30** along a line (load beam width direction line) **38**, which passes through the center of the fixing portion **30** (the above center is also the center of the slider **35**), and crosses a longitudinal center line **37** of the load beam **21** at a right angle. Each of the beam portions **31** and **32** has a length l_1 .

The beam portion **33** extends from the beam portion **31** towards the respective sides of the beam portion **31** so that the beam portion **33** crosses the beam portion **31** at a right angle and extends in parallel with the line **37**. Similarly, the beam portion **34** extends from the beam portion **32** towards the respective sides of the beam portion **32** so that the beam portion **34** crosses the beam portion **32** at a right angle and extends parallel to the line **37**. The beam portion **33** is joined to portions **40** and **41** of the load beam **21** in the periphery of the gimbal **25**. Similarly, the beam portion **34** is joined to portions **42** and **43** of the load beam **21** in the periphery of the gimbal **25**. In other words, the beam portion **33** extends from the portions **40** and **41** of the gimbal **25**, and the beam portion **34** extends from the portions **42** and **43** of the gimbal **25**. The distance between the center of the beam portion **33** and one of the two ends thereof is l_2 . Similarly, the distance between the center of the beam portion **34** and one of the two ends thereof is also l_2 .

The beam portion **33** and the beam portion **31** form a T-shaped beam **39A**. Similarly, the beam portion **34** and the beam portion **32** form a T-shaped beam **39B**. The beam portions **31**, **32**, **33** and **34** form an H-shaped beam. It will be noted that the fixing portion **30**, the first pair of beams **31**

and **32**, and the second pair of beams **33** and **34** are portions of the load beam **21**.

The length l_1 of the first pair of beams **31** and **32** is limited by the width **W1** of the load beam **21**. As the width **W1** of the load beam **21** is increased, the resonance frequency of a bend and twist of the load beam **21** becomes lower, and the flying characteristics of the slider **35** are degraded. For these reasons, the width **W1** cannot be increased. However, according to the first embodiment of the present invention, it is possible to increase the length l_2 of the second pair of beams **33** and **34** without being limited by the width **W1** of the load beam **21**. The second pair of beams **33** and **34** is formed so that $l_2 > l_1$. That is, each of the T-shaped beams **39A** and **39B** has a leg portion and an arm portion longer than the leg portion.

When a waviness of the magnetic disk being rotated is present or dust adheres to the magnetic disk, the magnetic head slider **35** is rotated in a pitching direction indicated by an arrow **44** in a state in which the first pair of beams **31** and **32** and the second pair of beams **33** and **34** are bent. At this time, a twist deformation occurs in the first pair of beams **31** and **32** of the gimbal **25**, and a bend deformation occurs in the second pair of beams **33** and **34**.

As indicated by an arrow **45**, the magnetic head slider **35** is rotated in a rolling direction also. At this time, bend deformations occur in the beams **31** and **32** in the respective directions opposite to each other, and bend deformations occur in the beams **33** and **34** in the respective directions opposite to each other.

FIG. 4 shows a resonance mode of the first-order bend. A deformation occurs in the elastic portion **23** formed at the root of the load beam **21**, and the first pair of beams **31** and **32** and the second pair of beams **33** and **34** are deformed in the same direction.

FIG. 5 shows a resonance mode of the first-order twist. A twist deformation occurs in the elastic portion **23** formed at the root of the load beam **21** in such a manner so the right and left portions of the elastic portion **23** have different heights. The beam located on the right side of the gimbal **25** is deformed so as to be formed into a convex shape facing upwards. The beam located on the left side of the gimbal **25** is deformed so as to be shaped into a convex facing downwards. When the lengths l_1 and l_2 are selected so that the length l_2 is equal to three or four times the length l_1 , the rotation stiffness responses of the slider in the pitching and rolling directions become sufficiently soft and are almost the same as each other.

As shown in FIG. 2, a composite type magnetic head **48** and four terminals **100A**, **100B**, **100C** and **100D** are provided in the magnetic head slider **35**. The magnetic head **48** includes an MR head for reproduction and an interactive type head for recording, these heads being integrated with each other. The magnetic head **48** is located at a rear end surface of the magnetic head slider **35** in a relative movement direction **46** with respect to the magnetic disk **222**.

As shown in FIGS. 6 and 7, lead wires **15A**, **15B**, **15C** and **15D** are connected to the terminals **100A**, **100B**, **100C** and **100D**, respectively. Each of the lead wires **15A** through **15D** has a diameter of, for example, $30\ \mu\text{m}$. The lead wires **15A**–**15D** are laid on the side opposite to the side on which the magnetic head slider **35** is mounted, and are attached to a center portion **36** of the fixing portion **30** by means of an adhesive **16**. Further, the lead wires **15A**–**15D** extend along the longitudinal center line **37** of the load beam **21** towards the base portion of the load beam **21**, and are fixed thereto at two points by means of the adhesive **16**.

Reference numbers 17₋₁, 17₋₂ and 17₋₃ respectively indicate a first fixing point, a second fixing point and a third fixing point at which the lead wires 15A through 15D are fixed by means of the adhesive 16. The first fixing point 17₋₁ moves in accordance with movement of the magnetic head slider 35. Hence, it is unnecessary to be concerned about the stiffness of portions of lead wires 15A through 15D between the terminals 100A–100D and the first fixing point 17₋₁ and to provide additional lengths of the lead wires 15A–15D. In FIG. 6, such additional lengths of the lead wires 15A–15D are not provided. The distance between the first fixing point 17₋₁ and the second fixing point 17₋₂ is long, and the stiffness of the lead wires 15A–15B between the fixing points 17₋₁ and 17₋₂ little affects the rotation stiffness of the gimbal 25.

The magnetic head supporting mechanism 20 has the following features. First, the rotation stiffness of the gimbal 25 is considerably small because of the characteristics of the T-shaped beams. Second, the gimbal 25 is supported at the four points 40–43, and hence, the resonance frequency of vibration of the gimbal 25 is high even when the second pair of beams 33 and 34 is long. Third, the end of the load beam 21 can be formed so that it has a small width W1, and hence the resonance frequency of vibration of the load beam 21 is high. Fourth, the flying stability of the magnetic head slider 35 is excellent due to the above first, second and third features. The fifth feature of the mechanism 20 is such that the first pair of beams 31 and 32 has a short length l₁ and is formed in the same plane. Hence, the first pair of beams 31 and 32 has a large strength with respect to force received in the contact start/stop operation, and a shear failure does not easily occur in the beams 31 and 32. The sixth feature of the mechanism 20 is such that the stiffness of the lead wires 15A–15D does not affect the rotation stiffness of the gimbal 25.

As has been described above, the gimbal 25 is formed so that a pair of T-shaped beams (which form an H-shaped beam) is provided with respect to the center of the gimbal 25, and hence a low rotation stiffness and a high resonance frequency are achieved. More specifically, the rotation stiffness of the mechanism 20 becomes one-third of that of the aforementioned IBM 3380 type head supporting mechanism, while the resonance frequency of the mechanism 20 is as high as that of the IBM 3380 type head supporting mechanism. As a result, it becomes possible to stably fly a compact slider having a low airbearing stiffness.

Tables 1 and 2 show characteristics of the head supporting mechanism 20 according to the first embodiment of the present invention supporting a 2 mm-length slider, and the IBM 3380 type head supporting mechanism supporting which a 3.2 mm-length slider.

TABLE 1

COMPARISON OF STIFFNESS (static characteristics by computer simulation)		
Stiffness	1st embodiment	3380 type
pitch stiffness	1.5 grf cm/rad	9.4 grf cm/rad
roll stiffness	1.5 grf cm/rad	5.1 grf cm/rad
up/down stiffness	0.55 grf/mm	2.4 grf/mm
equivalent weight ratio	0.74	0.72

TABLE 2

COMPARISON OF RESONANCE FREQUENCY (dynamic characteristic by computer simulation)		
Stiffness	1st embodiment	3380 type
1st bend	2.1 kHz	2.1 kHz
1st twist in-plane	2.3 kHz 8.5 kHz	2.6 kHz 5.7 kHz

In order to make the equivalent weight ratio ((supporting spring equivalent weight)/(slider weight) of the first embodiment equal to that of the IBM 3380 type mechanism, the total length of the supporting mechanism is short (10 mm), which is approximately half of that of the IBM 3380 type mechanism. Further, the thickness of the load beam 21 of the first embodiment is 25 μm, which is approximately one-third of that of the IBM 3380 type mechanism.

Table 1 shows data obtained by computer simulation. More specifically, Table 1 shows the pitch stiffness and roll stiffness of the gimbal 25 of the first embodiment, and the up/down stiffness of the load beam 21 thereof. Further, Table 1 shows the pitch stiffness and the roll stiffness of the gimbal of the IBM 3380 type mechanism, and the up/down stiffness of the load beam thereof. It can be seen from Table 1 that the rotation stiffness equal to one-third of the gimbal of the IBM 3380 type mechanism can be obtained by optimizing the width and length of the grooves in the gimbal 25.

Table 2 shows the resonance frequencies of the first embodiment and the conventional IBM 3380 type mechanism obtained by a computer simulation. The resonance frequencies of the first embodiment are similar to those of the IBM 3380 type mechanism.

As will be seen from the above, the magnetic head supporting mechanism according to the first embodiment of the present invention has a low stiffness and a high resonance frequency.

A description will now be given of a second embodiment of the present invention. In the following description, parts that are the same as those shown in FIG. 2 are given the same reference numbers.

FIG. 8 shows a magnetic head supporting mechanism 50 according to the second embodiment of the present invention. The mechanism 50 includes a gimbal 51. The gimbal 51 is formed so that the gimbal 25 shown in FIG. 2 is rotated about the center 36 by 90°. Two T-shaped beams 52 and 53 are arranged in the longitudinal direction of the load beam 21.

FIG. 9 shows a magnetic head supporting mechanism 60 having a gimbal 61 according to a third embodiment of the present invention. The gimbal 61 has the aforementioned first pair of beams 31 and 32, and a second pair of beams 33A and 34A. The beam 33A and the beam 31 form an acute angle α. Similarly, the beam 34A and the beam 32 form an acute angle equal to the acute angle α. With the above structure, it becomes possible to form, without increasing the width W1 of the load beam 21, the second pair of beams 33A and 34A so that the length 2×l_{2a} thereof is greater than the length 2×l₂ of the second pair of beams 33 and 34 shown in FIG. 2. Further, it is possible to narrow the end of the load beam 21. Hence, the rotation stiffness of the gimbal 61 is less than that of the gimbal 25 shown in FIG. 2. Thus, the magnetic head slider 35 in the third embodiment can be more stably flied than that in the first embodiment shown in FIG. 2.

FIG. 10 shows a magnetic head supporting mechanism 70 having a gimbal 71 according to a fourth embodiment of the present invention. A magnetic head slider 35A of the mechanism 70 includes flanges 72 and 73 formed on the respective sides of the slider 35A. A magnetic head slider fixing portion 30A of the gimbal 71 includes an opening 74 having a size corresponding to the magnetic head slider 35A. The opening 74 is of a rectangular shape defined by a rectangular frame 76. As shown in FIG. 10, the magnetic head slider 35A engages the opening 74, and the flanges 72 and 73 are made to adhere to the frame 76 by means of an adhesive. In this manner, the magnetic head slider 35A is fixed to the magnetic head slider fixing portion 30A.

As shown in FIG. 11, the center G of gravity of the magnetic head slider 35A is substantially located on the surface of the load beam 21. Hence, in a seek operation, the magnetic head slider 35A is moved by exerting a force on the center G of gravity. Thus, an unnecessary rotation force about the center G of gravity of the magnetic head slider 35A does not occur, and the unbalance of the magnetic head slider 35A is reduced. As a result, the magnetic head slider 35A can stably fly in the seek operation.

Further, the height of the magnetic head assembly can be reduced. Hence, it is possible to laminate layers of the head at reduced intervals and to provide an increased number of disks per unit length. As a result, it is possible to increase the volume storage density of the magnetic disk drive and hence the storage density.

FIG. 12 shows a magnetic head supporting mechanism 80 having a magnetic head slider 35B according to a fifth embodiment of the present invention. The magnetic head slider 35B has a flange 81 formed around the circumference thereof. The magnetic head slider 35B engages the opening 74, and the flange 81 is made to adhere to the magnetic head slider fixing portion 30A by means of an adhesive. That is, the fifth embodiment of the present invention differs from the fourth embodiment thereof in that the whole circumference of the magnetic head slider 35B is made to adhere to the fixing portion 30A. Hence, the adhesive strength is increased and the reliability of the magnetic head supporting mechanism is improved.

FIG. 13 shows a magnetic head supporting mechanism 90 according to a sixth embodiment of the present invention. FIG. 14 shows a free end of a load beam of the magnetic head supporting mechanism 90. The mechanism 90 is designed so that it does not have any influence of the stiffness of lead wires, which affect flying of the slider having a low airbearing stiffness. For example, when, in the case where four lead wires are connected between the slider and the load beam (see FIG. 6), each of the lead wires has a diameter of 30 μm and has an additional length (free length) of 1 mm, the rotation stiffness of the gimbal is approximately five times that of the gimbal in which there is no lead wire. This degrades the flying stability of the slider.

The magnetic head supporting mechanism 90 has wiring patterns 91, 92, 93 and 94, which are formed by patterning a copper thin film formed by, for example, plating by means of the photolithography technique. The wiring patterns 91-94 extend on a central portion of the lower surface of the load beam 21 in the longitudinal direction. Each of the wiring patterns 91-94 is approximately 5 μm thick and 50 μm wide. The thickness and width of the wiring patterns depend on the resistance of the conductive pattern and the capacity of the load beam 21.

Terminals 95A-95D made of copper are formed on the base portion of the load beam 21. Further, terminals

96A-96D are formed in a terminal area 30a of the magnetic head slider fixing portion 30 of the gimbal 25. The tops of the terminals 95A-95D and 96A-96D are plated by, for example, Au. This plating contributes to preventing exposure of copper and improving the bonding performance. Ends of the wiring patterns 91, 92, 93 and 94 are respectively connected to the terminals 95A, 95B, 95C and 95D. The other ends of the two wiring patterns 91 and 92 extend along the beams 33A and 31, and are connected to the terminals 96A and 96B, respectively. The other ends of the wiring patterns 93 and 94 extend along the beams 34A and 32 and are connected to the terminals 96C and 96D, respectively.

As shown in FIG. 15, the wiring patterns 91, 92, 93 and 94 are electrically insulated from the load beam 21 by means of an insulating film 97, and are covered by a protection film 98. The insulating film 97 and the protection film 98 are made of photosensitive polyimide and are grown to a thickness of approximately 5 μm . The insulating film 97 and the protection film 98 are respectively patterned by the photolithography technique. The thickness of the insulating film 97 is determined on the basis of a capacitance between the conductive pattern (made of Cu) and the load beam (made of stainless steel).

As will be described later, polyimide has heat-resistance enough for an annealing process. Since polyimide has photosensitivity, it can be easily patterned. Further, the polyimide films 97 and 98 have corrosion resistance, and excellent reliability.

It is likely that the terminals 95A-95D and 96A-96D are etched because these terminals are not covered by the protection film 98. In order to prevent the terminals 95A-95D and 96A-96D from being etched, the surfaces of these terminals are covered by an Au film (not shown) having a thickness of approximately 1 μm formed by plating or vapor deposition.

As shown in FIG. 16, the magnetic head slider 35 is adhered to the fixing portion 30 by means of an adhesive. The terminals 96A-96D are located at a right angle with respect to terminals 100A-100D of the magnetic head 48 formed on the end surface of the magnetic head slider 35, and are respectively connected to the terminals 100A-100D by means of Au balls 101A-101D. The Au balls 101A-101D are formed by means of, for example, a gold ball bonding device. In order to facilitate bonding, the terminals 96A-96D and terminals 100A-100D are located as shown in FIG. 16. In order to facilitate a crimp operation on the Au balls 101A-101D, the terminals 100A-100D are long in the direction of the height of the magnetic head slider 35 and are located so that these terminals 100A-100D face the terminals 96A-96D in the state where the head slider 35 is fixed to the fixing portion 30.

The wiring patterns 91-94 bypass holes 102A, 102B and 102C, as shown in FIG. 13 and extend up to an area close to the head slider 35. The hole 102C is used to fix the load beam 21 to the arm 22 (not shown in FIG. 13). The holes 102A, 102B and 102C are sized such that a tool can be inserted therein.

As shown in FIGS. 13 and 14, dummy patterns 103A-103D and 104A-104D are provided so that these dummy patterns are symmetrical to the bypassing portions of the wiring patterns 91-94 with respect to the holes 102A and 102B. The insulating film 97 and the protection film 98 are provided for the dummy patterns 103A-103D and 104A-104D in the same manner as the wiring patterns 91-94. The dummy patterns 103A-103D and 104A-104D

are provided in order to balance the mechanical stiffness of the load beam **21** in the direction of the width of the load beam **21**.

As shown in FIG. **14**, the wiring patterns **91–94** are arranged so that these patterns form a loop. This loop functions as an antenna, which receives noise components contained in the head signals. As the size of the loop is increased, the degree of the noise components is increased. In order to reduce the size of the loop, the wiring patterns **91** and **92** respectively connected to the terminals **96A** and **96B** are arranged between the hole **102A** and the magnetic head slider **35**, and all the wiring patterns **91–94** are gathered in the vicinity of the hole **102A**. In order to balance the stiffness in the direction of the width of the load beam, the dummy patterns **104A–104D** are formed. For the same reason as above, the dummy patterns **103A–103D** are formed in the vicinity of the hole **102B**.

As shown in FIG. **14**, auxiliary films **106** and **107** having a belt shape are formed along the right and left ends of the load beam **21**. The auxiliary films **106** and **107** are provided in order to receive a clamping force generated when the load beam **21** is clamped in a bending process which will be described later. Such a clamping force is also received by the wiring patterns **91–94**. The clamping force is distributed so that the clamping force is exerted on not only the wiring patterns **91–94** but also the auxiliary films **106** and **107**. Hence, it is possible to prevent the wiring patterns **91–94** from being damaged.

As shown in FIGS. **13** and **14**, a convex dummy pattern **108** is provided in order to prevent an adhesive from flowing from the fixing portion **30** when the slider **35** is fixed to the fixing portion **30** and to prevent the slider **35** from being tilted due to the thickness of the wiring patterns. More particularly, the convex pattern **108** is used to form a groove in which adhesive used to fix the slider **35** is saved between the pattern **108** and the terminals **96A–96D**. Further, the convex pattern **108** is designed to have the same height as the patterns having the terminals **96A–96D**. If the dummy pattern **108** is not used, the slider **35** will be inclined with respect to the fixing portion **30** due to the height of the terminals **94A–94D**. This degrades the flying stability of the heads. The convex pattern **108** can be formed by a cooper-plated thin film similar to the wiring patterns **91–94**. The protection film **98** covers the convex pattern **108**. The adhesive is provided on a step part between the wiring patterns and the convex pattern **108**.

The load beam **21** is produced by a process shown in FIG. **17**. First, a pattern formation step **110** is performed. More particularly, photosensitive polyimide is coated on a stainless plate. The insulating film **97** is formed by the photolithography technique. A copper film is formed by the plating process, the vapor deposition process or the like, and is patterned into the wiring patterns **91–94** by the photolithography technique. Thereafter, photosensitive polyimide is coated and is patterned into the protection film **98** and the auxiliary films **106** and **107** by the photolithography technique. Polyimide can be coated by a spin-coat process, and is patterned and etched. A thin film, such as a Cr film can be formed in order to improve the adhesiveness between the insulating film and the Cu film and between the Cu film and the protection film and to improve the reliability of the adhesion.

Next, an etching step **111** is performed in order to form the openings **26–29** and the holes **102A–102C** and the outward form of the load beam in the stainless plate. FIG. **18** shows load beams **202** before punching for cutting off bridge

portions (not shown) to provide pieces, so that the load beams **202** are formed in a stainless plate **201** and arranged in rows and columns.

Then, a bending step **112** is performed by bending the respective ends of each of the load beams **202** formed in the stainless plate **201**, so that ribs **21a** are formed. The bending step **112** can be performed by press so that the load beams **202** are processed at the same time.

Finally, an annealing step **113** is performed at a temperature of approximately 400°C ., so that internal stress can be removed. Further, a slider adhering step and an Au bonding step can be automatically carried out before the load beams **202** are punched. Hence, it is possible to automatically perform the production process shown in FIG. **17** and reduce the number of steps and the cost thereof.

The load beam **21** can be produced without performing the annealing step **113**. In this case, as is shown in FIG. **19**, the pattern formation step **110** and the etching step **111** are performed, and subsequently the slider adhering step and the Au bonding step are carried out. Thereafter, the bending step **112** is carried out to form the ribs **21a**.

As shown in FIG. **20**, when interactive type heads **48A** and **48B** for recording and reproduction are used as magnetic heads, the magnetic head slider **35** has the aforementioned two terminals **100A** and **100B**. In the gimbal **25**, the two wiring patterns **91A** and **92A** are provided so that these wiring patterns extend on only the beams **32** and **34A**, while two dummy patterns **210** and **211** are provided so as to extend on the beam **31** and **33A** in order to balance the mechanical stiffness of the load beam **21** in the direction of the width of the load beam **21**.

The magnetic head supporting mechanism **90** has the following features.

First, since the wiring patterns **91–94** are formed on the load beam **21**, it is not necessary to provide tubes for passing the lead wires through the load beam **21**. Hence, it is possible to prevent unbalanced force caused by the lead wires and tubes from being exerted on the magnetic head slider **35** and to stably fly the magnetic head slider **35**.

Second, due to use of the dummy patterns **103A–103D** and **104A–104D**, the rotation stiffness of the load beam **21** does not have polarity. Hence, the magnetic head slider can fly stably.

Third, the crimp connection using the Au balls **101A–101D** enables automatic assembly and non-bire bonding between head terminals and pattern terminals.

In the aforementioned embodiments of the present invention, the beams may be curved.

A description will now be given of a magnetic head supporting mechanism suitable for a more compact magnetic disk drive according to a seventh embodiment of the present invention.

FIG. **21** shows a back surface of a magnetic head supporting mechanism **230** according to the seventh embodiment of the present invention. FIG. **22** shows a 1.8-inch-type magnetic disk drive **231** to which the magnetic head supporting mechanism **230** is applied.

The magnetic disk drive **231** has an enclosure **232** having almost the same dimensions as those of an IC memory card. In the enclosure **232**, provided are a magnetic disk **233** having a diameter of 1.8 inches, and an actuator to which two sets of magnetic head supporting mechanisms are attached. The magnetic disk drive **231** is more compact than the magnetic disk drive **220** shown in FIG. **3**.

A magnetic head slider **35C** is made compact in accordance with light-sizing of the magnetic disk drive **231**. More

particularly, dimensions $a \times b$ of the magnetic head slider **35C** are $0.8 \text{ mm} \times 1.0 \text{ mm}$, and are approximately one-quarter the area of the magnetic head slider **35** shown in FIG. 2. In order to stably fly the compact magnetic head slider **35C**, it is necessary to considerably reduce the stiffness without decreasing the resonance frequency, as compared with the magnetic head supporting mechanism **30**.

A load beam **235** shown in FIG. 21 is made of stainless, and has a base portion fixed to an arm **236** of the actuator **234** (see FIG. 22). The load beam **235** has a width W_2 of approximately 2 mm, a length L of approximately 9 mm, and a thickness t of approximately $25 \mu\text{m}$, and is approximately a half of the volume of the load beam **21** shown in FIG. 2. The load beam **235** is diminished, and hence the resonance frequency of bending which will be described later is high.

The load beam **235** is a sheet-shaped piece, and a flat plate piece to which a bending process has not been subjected. Hence, there is no problem of a bending process error which degrades the flying stability of the magnetic head slider. The load beam **235** includes a load beam main body **237** and a gimbal **238** located on the end side of the load beam **235**. The gimbal **238** has a substantially U-shaped opening (through hole) **239** formed in the load beam **235**. The gimbal **238** includes a magnetic head slider fixing portion **240**, a first beam **241**, a second beam **242**, a third beam **244**, and a connecting portion **243**.

The magnetic head slider fixing portion **240** has a size corresponding to the magnetic head slider **35C**. The first beam **241** and the second beam **242** extend along respective longitudinal ends of the load beam **235** from the end thereof. The connecting portion **243** extends in the direction of the width of the load beam **235**, and connects the first beam **241** and the second beam **242** together. The third beam **244** extends from the connecting portion **243** to the magnetic head slider fixing portion **240** in the longitudinal direction of the load beam **235**. The magnetic head slider fixing portion **240** is connected to the main body **237** of the load beam **235** via the third beam **244**, the connecting portion **243** and the first and second beams **241** and **242**. Hence, the rotation stiffness of the load beam **230** can be reduced to a small value due to bending of the entire beams.

As shown in FIG. 21, holes **245**, **246** and **247** with which a tool is engaged, and a pair of slits **248** and **249** are formed in the main body **237** of the load beam **235**. Adjustment slits **248** and **249** are used to reduce the rotation stiffness of the load beam. The holes **245**, **246** and **247** and the slits **248** and **249** are formed by etching. The connectors **95A–95D**, **96A–96D** and the wiring patterns **91–94** are formed symmetrically with respect to the longitudinal direction of the load beam **235**. The magnetic head slider **35C** is made to adhere to the fixing portion **240**, and the terminals **96A–96D** and **100A–100D** are respectively connected to each other by means of Au balls, as in the case shown in FIG. 16.

The structure shown in FIG. 21 does not use dummy patterns because the length and the width of the load beam **235** are less than those of the load beam shown in FIG. 13 and the loop formed by the wiring patterns is smaller than that shown in FIG. 13. However, it is preferable to arrange the wiring patterns and provide the dummy patterns as shown in FIGS. 13 and 14 in order to reduce the noise from the heads.

As shown in FIGS. 23A and 23B, the free end of the arm **236** is bent so that a substantially V-shaped cross section of the arm **236** is formed in which the “V” is inverted. The free end of the arm **236** has an upward slant portion **236a** and a downward slant portion **236b** declined at an angle θ with respect to the horizontal direction.

The magnetic disk drive **231** uses two magnetic head supporting mechanisms **230** so that the single magnetic disk **233** is sandwiched between the mechanisms **230**. As shown in FIG. 24, the load beam **235** causes the magnetic head slider **35C** to come into contact with the magnetic disk **233** when the magnetic disk **233** is not being rotated. At this time, the main body **237** of the load beam **235** is caused to be bent and elastically deformed. The elastic force stored in the main body **237** of the load beam **235** generates a load F_1 , which urges the magnetic head slider **35C** towards the magnetic disk **233**.

Since the arm **236** is bent in the form of the inverted “V”, a wide gap **250** can be formed between an end **236c** of the arm **236** and the magnetic disk **233**, as compared with a case indicated by a two-dot chained line in which the arm **236** is simply bent downwards.

A description will now be given of a moment exerted on the magnetic head slider **35C** by means of the load beam **235** when the load beam is loaded on the disk. As shown in FIG. 25, the main body **237** of the load beam **235** and the third beam **244** are bent. Hence, a moment is exerted by a center **251** of the magnetic head slider **35C**. A moment M_1 directed counterclockwise is exerted by the load beam main body **237** and the first and second beams **241** and **242**. A moment M_2 directed clockwise is exerted on the third beam **244**. The dimensions of the load beam **235** are selected so that the moments M_1 and M_2 are balanced. For example, the load beam **235** is 9 mm long, and the gimbal **238** is 2.5 mm long. Further, the length and width of the main body **235** of the load beam **237** are 5.7 mm and 2 mm, respectively. With the above structure, it is possible to stably fly the magnetic head slider **35C**.

A description will now be given, with reference to FIG. 21, of pitching and rolling of the magnetic head slider **35C**.

(1) Pitching

The magnetic head slider **35C** is rotated in the pitching direction indicated by arrow **44** in such a manner that the first, second and third beams **241**, **242** and **244** and the load beam main body **237** are bent. At this time, all the beams **241**, **242** and **244** are bent so as to be deformed in the form of arch shapes. The gimbal **238** is bent and hence the load beam main body **237** is bent. Hence, the pitch stiffness can be greatly reduced.

(2) Rolling

The magnetic head slider **35C** is rotated in the rolling direction indicated by arrow **45** in such a manner that the first and second beams **241** and **242** are respectively bent in the opposite directions and the load beam main body **237** is twisted. At this time, the gimbal **238** is bent and hence the load beam main body **237** is bent. Hence, the rolling stiffness can be greatly reduced.

A description will now be given of the first-order bend and the first-order twist of the magnetic head supporting mechanism **230** obtained when the load beam is vibrated.

(1) First-order Bend

The load beam **235** is bent and deformed, as shown in FIG. 26. More specifically, the load beam main body **237**, and the first, second and third beams **241**, **242** and **244** of the gimbal **238** are bent as shown in FIG. 24. The overall load beam **235** is formed flexibly, but the resonance frequency of the first-order bend is high, while the stiffness is small.

(2) First-order Twist

The load beam **235** is twisted as shown in FIG. 27. The gimbal **238** is deformed and hence the load beam main body **237** is deformed. Hence, the overall load beam **235** is flexibly formed, but the resonance frequency of the first-order twist is high while the stiffness thereof is low.

Tables 3 and 4 show characteristics of the magnetic head support mechanism **230** according to the seventh embodiment of the present invention and the magnetic head supporting mechanism **30** of the first embodiment thereof shown in FIG. 2.

TABLE 3

COMPARISON OF STIFFNESS (static characteristics by computer simulation)		
Stiffness	7th embodiment	1st embodiment
pitch stiffness	0.44 grf cm/rad	1.5 grf cm/rad
roll stiffness	0.24 grf cm/rad	1.5 grf cm/rad
up/down stiffness	0.36 grf/mm	0.55 grf/mm
equivalent weight ratio	0.76	0.74

TABLE 4

COMPARISON OF RESONANCE FREQUENCY (dynamic characteristic by computer simulation)		
Stiffness	7th embodiment	1st embodiment
1st bend	1.6 kHz	2.1 kHz
1st twist	4.4 kHz	2.3 kHz
in-plane	7.1 kHz	8.5 kHz

More particularly, Table 3 the pitch stiffness, the roll stiffness, and the up/down stiffness of the load beam **235** obtained by means of a computer simulation. It can be from Table 3 that the pitch stiffness and the roll stiffness of the seventh embodiment of the present invention are approximately one-quarter of those of the first embodiment thereof.

Table 4 shows the resonance frequencies of the first and seventh embodiments of the present invention obtained by a computer simulation. It can be seen from Table 4 that the first-order bend resonance frequency, the first-order twist resonance frequency and the lateral resonance frequency are kept very high.

It can be seen from Tables 3 and 4 that the magnetic head supporting mechanism **230** according to the seventh embodiment of the present invention has a resonance frequency as high as that of the magnetic head supporting mechanism **30** according to the first embodiment, and stiffness much less than that of the mechanism **30**. Hence, the compact magnetic head slider **35C** can be stably flied.

In an alternative of the load beam, the base portion of the load beam **237** is bent, so that the load beam is supported in the same manner as shown in FIG. 2 and the load F1 shown in FIG. 24 is obtained. In this case, only portions **255** and **256** outside of the slits **248** and **249** are bent. Hence, unnecessary strain is not exerted on the wiring patterns **91-94** located between the slits **248** and **249**.

A first variation of the gimbal **238** of the load beam **235** will be described. A gimbal **238₋₁** shown in FIG. 28 has a first beam **244₋₁** having a long width A, and an opening **239₋₁** having a long length B. First and second beams **241₋₁** and **242₋₁** are long.

FIG. 29 shows a second variation **238₋₂** of the gimbal **238**. The gimbal **238₋₂** has first and second beams **241₋₂** and **242₋₂** each having a small width C.

FIG. 30 shows a third variation **238₋₃** of the gimbal **238**. The gimbal **238₋₃** has first and second variations **241₋₃** and **242₋₃** having a large width D.

FIG. 31 shows a fourth variation **238₋₄** of the gimbal **238**. The gimbal **238₋₄** has a fourth beam **260** connecting the center of the end of the magnetic head slider fixing portion

240 and the load beam main body **237** together. The fourth beam **260** functions to prevent a deformation of the magnetic head slider fixing portion **240**, but increases the rotation stiffness. Hence, it is desired that the width of the fourth beam **260** be as small as possible and the length thereof are as long as possible.

FIG. 32 shows a fifth variation **238₋₅** of the gimbal **238**. The gimbal **238₋₅** has first and second arch-shaped beams **241₋₅** and **242₋₅**.

As shown in FIG. 33, a bent connecting plate **261** is fixed to an arm **236A**, and the load beam **235** is fixed to the connecting plate **261**. Hence, it is not necessary to subject the arm **236A** to bending stresses.

In the variations shown in FIGS. 28 through 32, it can be said that the third beam **244** shown in FIG. 21 has the same width as the fixing portion **240** and is integrated with the fixing portion **240**.

In the first through sixth embodiments, the load applied to the magnetic head slider is generated by bending the spring portion of the load beam. Alternatively, it is possible to employ the arm fixing structure used in the seventh embodiment of the present invention in which the spring portion is kept flat.

The present invention is not limited to the specifically disclosed embodiments and variations, and other variations and modifications may be made without departing from the scope of the present invention.

What is claimed is:

1. A head supporting assembly adapted to elastically support a head slider, said head supporting assembly comprising:

a head slider fixing portion on which the head slider is mounted;

first and second beams extending along a longitudinal direction of said head supporting assembly, said first and second beams being spaced apart and entirely separated from the head slider fixing portion;

a third beam which connects an end of the head supporting assembly to a first end of the head slider fixing portion;

wiring patterns attached to at least one of said first, second and third beams; and

terminals formed on the head slider fixing portion and connected to said wiring patterns,

wherein said wiring patterns are attached to a side of said head supporting assembly on which said head slider is located.

2. The head supporting assembly recited in claim 1, wherein a first portion of said wiring patterns passes through said first beam and a second portion of said wiring patterns passes through said second beam.

3. The head supporting assembly recited in claim 2, wherein said first and second portions of said wiring patterns are equal in size.

4. The head supporting assembly as recited in claim 1, wherein a second end of said head slider fixing portion opposite said first end is entirely separated from said suspension plate assembly.

5. A load beam adapted for use in a magnetic disk drive, comprising:

a suspension plate assembly having a gimbal portion at one end, said suspension plate assembly having at least one opening in the gimbal portion, said gimbal portion including at least three beam portions and at slider fixing portion adapted for mounting a head slider,

wherein at least two of said beam portions are formed about a longitudinal center-line of said suspension plate

17

assembly on either side of said slider fixing portion and are entirely separated from said slider fixing portion, wherein said slider fixing portion is connected to said suspension plate assembly only through a remaining beam portion and is flexibly supported only by said remaining beam portion,

wherein said load beam further comprises wiring patterns attached to said suspension plate assembly, said slider fixing portion having terminals connected to said wiring patterns, and

wherein said wiring patterns are attached to a side of said suspension plate assembly on which said head slider is located.

6. The load beam recited in claim 5, wherein a first portion of said wiring patterns passes through one of said beam

18

portions formed about the longitudinal center-line of said suspension plate assembly, and a second portion of said wiring patterns passes through another of said beam portions formed about the longitudinal center-line of said suspension plate assembly.

7. The load beam recited in claim 6, wherein said first and second portions of said wiring patterns are equal in size.

8. The load beam recited in claim 5, wherein said remaining beam portion connects a first end of said slider fixing portion with said one end of said suspension plate assembly and a second end of said slider fixing plate opposite said first end is entirely separated from said suspension plate assembly.

* * * * *

UNITED STATES PATENT AND TRADEMARK OFFICE
CERTIFICATE OF CORRECTION

PATENT NO. : 6,212,041 B1
DATED : April 3, 2001
INVENTOR(S) : Ohwe et al.

Page 1 of 1

It is certified that error appears in the above-identified patent and that said Letters Patent is hereby corrected as shown below:

Title page.

Item [63], change "Continuation of application No. 08/475,181, filed on Jun. 7, 1995, now Pat. No 6,002,548." to -- Continuation of application No. 08/475,181, filed on Jun. 7, 1995, now Pat. No. 6,002,548, which is a division of application No. 08/110,771, filed on Aug. 23, 1993, abandoned. --.

Signed and Sealed this

Thirteenth Day of November, 2001

Attest:

Nicholas P. Godici

Attesting Officer

NICHOLAS P. GODICI
Acting Director of the United States Patent and Trademark Office