

Nov. 15, 1927.

P. J. DANDENEAU

1,649,513

COTTER PIN TOOL

Filed Dec. 15, 1926

2 Sheets-Sheet 1

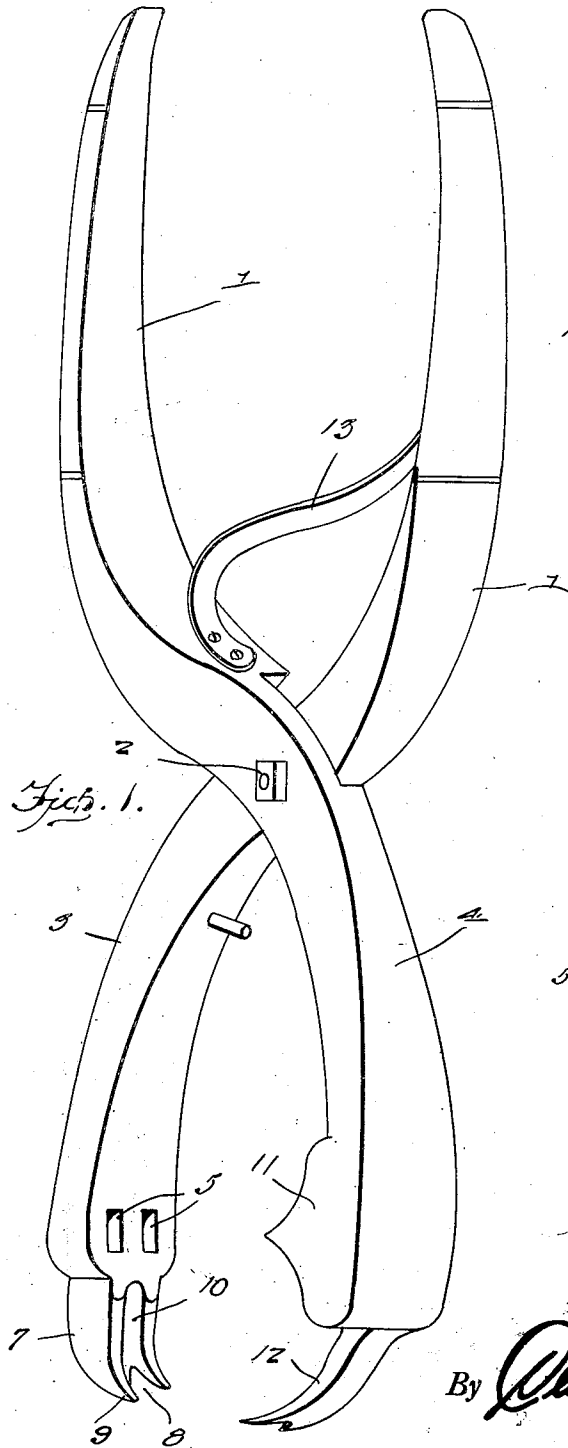

Fig. 2.

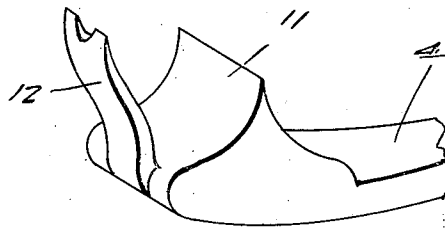
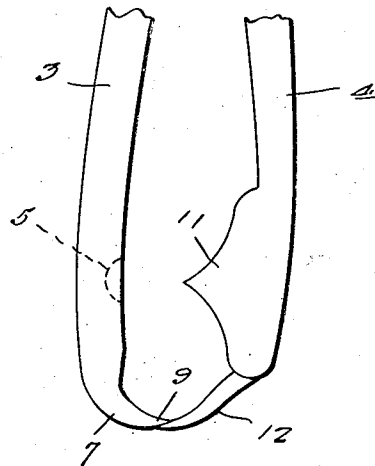

Fig. 3.



Inventor
Paul J. Dandeneau

By *Clarence W. Brien*

Attorney

Nov. 15, 1927.

P. J. DANDENEAU

1,649,513

COTTER PIN TOOL

Filed Dec. 15, 1926

2 Sheets—Sheet 2

Fig. 4.

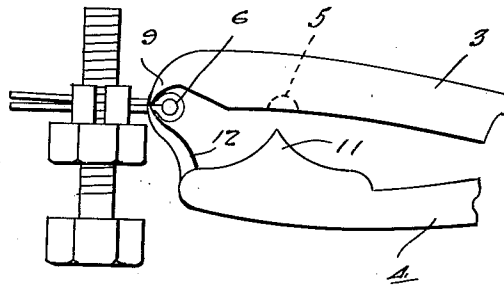

Fig. 5.

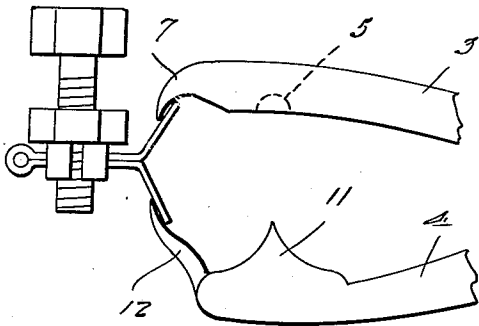

Fig. 6.

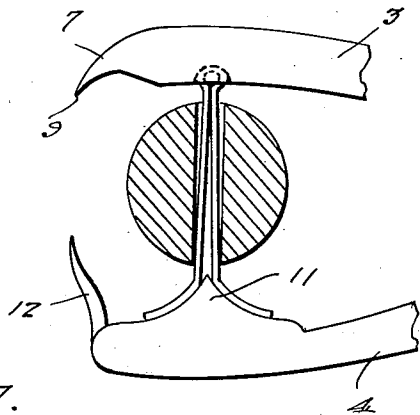
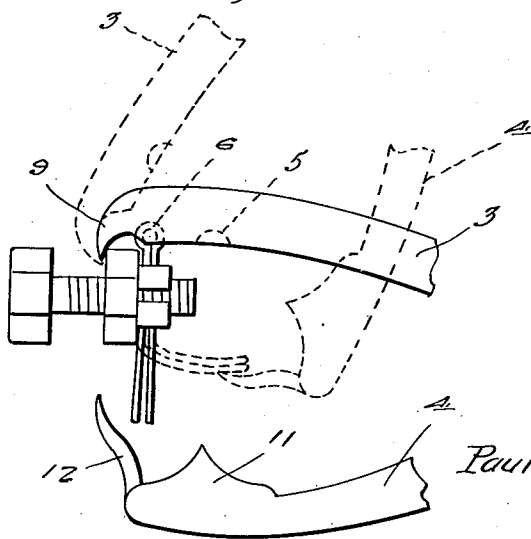

Fig. 7.



Inventor

Paul J. Dandeneau

By *Clarence A. O'Brien*
Attorney

Patented Nov. 15, 1927.

1,649,513

UNITED STATES PATENT OFFICE.

PAUL J. DANDENEAU, OF LAWDALE, CALIFORNIA.

COTTER-PIN TOOL.

Application filed December 15, 1926. Serial No. 154,983.

This invention relates to an improved tool which is especially adapted for use in connection with cotter pins to facilitate application and removal of the same.

Briefly, the invention has reference to a structure of this kind which includes cooperating claw members of a configuration to effectively engage either the head or the prong of the cotter pin, for withdrawing, inserting, spreading prongs, et cetera.

Other structural details, features and advantages of the invention will become apparent from the following description and claim.

In the accompanying drawings forming a part of this application and in which like numerals are employed to designate like parts throughout the same:

Figure 1 is a perspective view of the complete tool constructed in accordance with the invention.

Fig. 2 is an enlarged detail perspective view of certain of the details.

Fig. 3 is a side view of fragmentary portions of the jaw portions showing the pin engaging members together.

Fig. 4 is a view somewhat like Fig. 3 showing said members engaged with the headed end of a cotter pin for extracting the same.

Fig. 5 is a view showing the manner in which these tools are used for bending the prongs together for subsequent removal of the pins.

Fig. 6 is a view showing the manner in which the prongs are spread.

Fig. 7 is a view showing the manner in which the prongs are bent for securing the same in place.

Referring to the drawings in detail it will be seen that the reference character 1 designates the handles which are disposed in crossed relation and pivotally connected together as at 2. The portions extending outwardly beyond the handles form what may be defined as jaw portions 3 and 4 respectively. The jaw portion 3 is provided adjacent its outer end with two or more recesses 5 forming sockets for reception of the head 6 of a cotter pin. Formed integral with the free end portion is an extension 7 of longitudinally curved configuration, the same being bifurcated at its free end as at 8 and the furcations 9 serving as jaws to straddle the shank of the cotter pin, et cetera. The underside of this pin-gripping extension is

formed with a groove 10 as shown plainly in Fig. 1. Formed integral with the free end portion of the jaw member 4 is an enlargement 11 having a V-shaped central portion acting as a spreader. The apex of this spreader is located opposite the aforesaid recesses 5. The reference character 12 designates an appropriately curved claw for cooperation with the jaws 9. The gripping fingers of the claw are shaped to overlap the jaws 9 when the members 3 and 4 are in the relationship shown in Fig. 3, for instance. It is yet to be pointed out that a suitable spring 13 is employed between the handles and on the right hand side of the pivotal connection 2 in Fig. 1 to hold the jaw members 3 and 4 normally spaced apart.

The normal position of the parts is represented in Fig. 1. The extreme closed position is represented in Fig. 3. A similar position is represented in Fig. 4 wherein it will be seen that the jaws 9 straddle the shank of the cotter pin while the gripping fingers of the claw 12 also straddle the same so that by holding the handles together against the tension of the spring 13, the cotter pin may be readily extracted from the bolt in which it is mounted. Assuming that the cotter pin must be withdrawn and that the ends of the prongs have been bent apart in an obvious manner (as represented in Fig. 5) and it is desired to move them together to facilitate extraction, this is done by engaging the member 7 with one prong and the claw 12 with the other prong and then moving the handles together to also move the bent prongs together. Assuming that the cotter pin has just been inserted through a hole in the bolt and it is desired to spread the prongs, this is done by inserting the head in one of the recesses 5 and engaging the free end of the prongs with the spreader 11 as represented in Fig. 6. Obviously by moving the jaw members 3 and 4 towards each other, the spreading action will take place. Assuming that the cotter pin is to be bent somewhat as represented by dotted lines in Fig. 7, this is done by engaging the jaws 9 behind the retaining nut and bringing the claw 12 against the free end portions of the prongs and then moving the tool from the full line position to the dotted line position represented.

Undoubtedly, by considering the details of description in connection with the drawings a clear understanding of the construction as

well as the method of use of the invention will be had, and therefore a more lengthy description is thought unnecessary.

While the preferred embodiment of the invention has been shown and described, it is to be understood that minor changes coming within the field of invention claimed may be resorted to if desired.

I claim:

10 A cotter pin tool comprising a pair of levers arranged in crossed pivotally connect-

ed relation, said levers including handle portions and jaw portions, the free end of one jaw portion being provided with a longitudinal groove and terminating in jaws at opposite sides of said groove, and a claw extending from the end portion of the complementary jaw and having a notched end portion arranged to overlap said gripping jaws.

In testimony whereof I affix my signature.

PAUL J. DANDENEAU.