



- (51) International Patent Classification:
H04N 7/15 (2006.01) G06F 9/54 (2006.01)
H04N 21/41 (2011.01) H04M 3/56 (2006.01)
- (21) International Application Number: PCT/EP2012/068166
- (22) International Filing Date: 14 September 2012 (14.09.2012)
- (25) Filing Language: English
- (26) Publication Language: English
- (30) Priority Data:
61/534,592 14 September 2011 (14.09.2011) US
13/270,659 11 October 2011 (11.10.2011) US
61/635,219 18 April 2012 (18.04.2012) US
- (71) Applicant (for all designated States except US): **BARCO N. V.** [BE/BE]; Pres. Kennedypark 35, B-8500 Kortrijk (BE).
- (72) Inventors; and
- (75) Inventors/Applicants (for US only): **BEEL, Koen Simon Herman** [BE/BE]; Gemete 19, B-9080 Lochristi (BE). **NIR, Yoav** [BE/BE]; Lentedreef 21, B-8930 Rekkem (BE). **LOUWET, Filip Josephine Johan** [BE/BE]; Nieuwstraat 20, B-9910 Knesselare (BE). **COEN, Guy** [BE/BE]; Louis Camustraat 25, B-9300 Aalst (BE).

- (74) Agent: **MICHALSKI HÜTTERMANN & PARTNER**; PATENTANWÄLTE, Neuer Zollhof 2, 40221 Düsseldorf (DE).
- (81) Designated States (unless otherwise indicated, for every kind of national protection available): AE, AG, AL, AM, AO, AT, AU, AZ, BA, BB, BG, BH, BN, BR, BW, BY, BZ, CA, CH, CL, CN, CO, CR, CU, CZ, DE, DK, DM, DO, DZ, EC, EE, EG, ES, FI, GB, GD, GE, GH, GM, GT, HN, HR, HU, ID, IL, IN, IS, JP, KE, KG, KM, KN, KP, KR, KZ, LA, LC, LK, LR, LS, LT, LU, LY, MA, MD, ME, MG, MK, MN, MW, MX, MY, MZ, NA, NG, NI, NO, NZ, OM, PA, PE, PG, PH, PL, PT, QA, RO, RS, RU, RW, SC, SD, SE, SG, SK, SL, SM, ST, SV, SY, TH, TJ, TM, TN, TR, TT, TZ, UA, UG, US, UZ, VC, VN, ZA, ZM, ZW.
- (84) Designated States (unless otherwise indicated, for every kind of regional protection available): ARIPO (BW, GH, GM, KE, LR, LS, MW, MZ, NA, RW, SD, SL, SZ, TZ, UG, ZM, ZW), Eurasian (AM, AZ, BY, KG, KZ, RU, TJ, TM), European (AL, AT, BE, BG, CH, CY, CZ, DE, DK, EE, ES, FI, FR, GB, GR, HR, HU, IE, IS, IT, LT, LU, LV, MC, MK, MT, NL, NO, PL, PT, RO, RS, SE, SI, SK, SM, TR), OAPI (BF, BJ, CF, CG, CI, CM, GA, GN, GQ, GW, ML, MR, NE, SN, TD, TG).

Published:
— with international search report (Art. 21(3))

[Continued on next page]

(54) Title: ELECTRONIC TOOL AND METHODS FOR MEETINGS

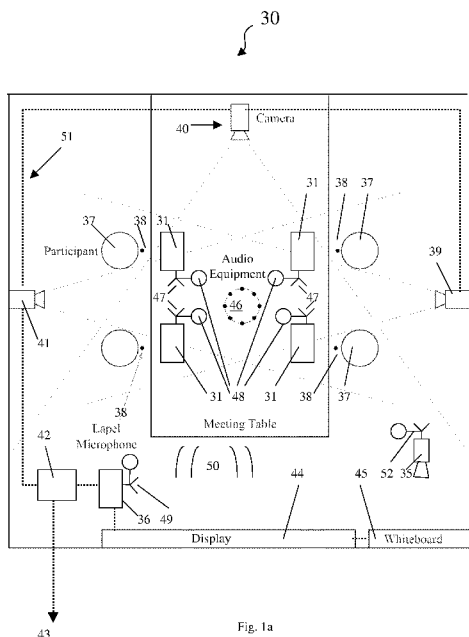

Fig. 1a

(57) Abstract: An electronic meeting tool and method for communicating arbitrary media content from users at a meeting is described. These can include a node configuration means adapted to operate a display node of a communications network, the display node being coupled to a first display. The node configuration means is adapted to receive user selected arbitrary media content and to control display of the user selected arbitrary media content on the first display. At least one peripheral device adapted to communicate the user selected arbitrary media content via the communications network is provided, wherein the peripheral device is a connection unit comprising: (e) a connector adapted to couple to a port of a processing device having a second display, a memory and an operating system; and (f) a transmitter for communicating with the communications network. A program is provided that is adapted to be loaded onto the processing device and to run on the operating system of the processing device, said program being adapted to obtain user selected arbitrary media content, said program leaving a zero footprint on termination. An input device is provided to allow the user to carry out a user action that triggers transfer of said user selected arbitrary media content to said transmitter through said port.

WO 2013/037979 A1

- *before the expiration of the time limit for amending the claims and to be republished in the event of receipt of amendments (Rule 48.2(h))*

ELECTRONIC TOOL AND METHODS FOR MEETINGS

The present invention relates to electronic tools for meetings including methods or devices for providing connection to a communications network, to networks or
5 methods of operating the network, methods or devices for use in displaying media content as well as software for performing any of these methods.

Technical background

10 Tools for collaboration

Allowing *ad hoc* groups of persons to communicate with each other is one of the fundamental aspects of collaboration, problem solving, negotiation, teaching and education, etc. To assist in communication, there has been an explosion of electronic communication tools such as electronic conferencing tools, e.g. synchronous and
15 asynchronous conferencing, online chat, Instant Messaging, audio conferencing, videoconferencing, data conferencing, application sharing, remote desktop sharing, electronic meeting systems, collaborative management (coordination) tools, project management systems, knowledge management systems, and social software systems.

20 One classic approach is the lecture or seminar often involving a presentation using presentation software. To a large extent the traditional single person presentation or lecture has been maintained with the audience being in a rather passive mode as far as determining, constructing, augmenting or modifying the information to be presented is concerned.

25

As with other business processes, meetings are going digital. Increasingly, people are using computer technology alone and in conjunction with broadband networks to support their meeting objectives prior to and during an actual meeting. For example, e-mail is used to pass around files for people to read prior to a meeting.

30

Collaborative workspaces in corporate networks and on the Internet offer geographically distributed collaborators a virtual repository for documents related to a project or a meeting. Electronic meeting support systems, such as interactive network-

connected white boards and videoconferencing appliances, are available for the benefit of those who share the same room as well as those who are in remote locations.

The AMIDA Final Public Report describes the overall methodology behind the
5 development of meeting support technologies. It reports that numerous studies confirm
that meetings dominate the way people work. Namely, according to a study conducted
by MCI Worldcom in 2003 a business person participates in 60 meetings per month.
People meet in groups for a multitude of reasons. They interact in numerous
predictable and unpredictable ways and the results of their interactions are as varied as
10 the people who participate and the projects on which they are collaborating or
communicating. Studies of business processes also reveal that approximately 80% of
the “workload” associated with a project or process happens in preparation for a
meeting. In other words, many people view the “live” meeting as a milestone or
deadline by which they can pace and measure their productivity and that of their
15 colleagues. Unfortunately, for many information managers, being in perpetual
meetings has reduced their ability to prepare adequately for the next meeting,
perpetuating a vicious and negative cycle.

However, Marc Al-Hames et al. report in “Audio-Visual Processing in Meetings:
20 Seven Questions and Current AMI Answers”, that although large parts of working
days are consumed by meetings and conferences, unfortunately a lot of them are
neither efficient, nor especially successful. They report a study in which people were
asked to select emotion terms that they thought would be frequently experienced in a
meeting. The top answer – mentioned from more than two third of the participants –
25 was “boring”; furthermore nearly one third mentioned “annoyed” as a frequently
perceived emotion.

The conclusion is that despite the plethora of electronic aids to meetings, fundamental
problems in handling meetings have not been solved. In fact organising and
30 conducting meetings in a business context involves a large number of factors.

Participation

A lack of efficiency of meetings is addressed in the article “Mood indicators on

electronic meeting tools” IBM, IP.com number: IPCOM000011711D, Publication Date: March 12, 2003. This article addresses the issue that the lack of direct feedback makes meetings clumsy, inefficient and often unproductive. It proposes a “mood indicator” as well as an “I want to ask a question” indicator which allow the presenter to choose an appropriate moment to pause, change track or field a question. It is argued that interrupting a presenter in full flow can be awkward; however, sometimes it is difficult to get an opportunity to ask a question or make a comment when many different people are trying to make their voices heard. In a similar vein, US6966035 suggests displaying a “murmur frame” for a participant to express a view. To increase user participation, US 2010/0087139 discloses a system for sending a selection to another computer, and US 2006/0095376 discloses a system for secure voting. Commenting, voting or selecting requires that a central authority provides the information that is to be selected or commented or voted on. Hence, these proposals still leave a central figure such as the presenter in a dominating position and the other members of the meeting are largely an audience with limited selection or voting or participation rights.

A further problem with meetings is that someone is usually late or has to leave early. With the person arriving late one has to decide if the meeting is interrupted and a summary of the proceedings so far is given. For the person leaving early (often a senior person), subsequent discussions can go missing. If there is a notes taker, this provides a personal summary of the meeting – but not an objective one. Presents systems do not provide an optimal solution.

25 Legal and security issues

A legal requirement of a meeting is that presentations, comments and submissions need to be completely reproducible – in some circumstances, e.g. in a share holders’ meeting, the events in the meeting should be subject to total recall. Computer-supported collaborative work technologies, particularly those which capture human verbal and non-verbal communications (audio and video interaction) in addition to text and graphics generated during a meeting, promise to have a long term impact on how people will prepare for and behave during and following meetings. In addition, connecting to a network brings the danger of virus, malware or spyware transfer in

either direction, and there is danger of copying of confidential information.

Practical Difficulties

Scalability and ease of use

- 5 There are even more fundamental problems with using electronic tools in meetings. If two persons want to make two presentations then usually either both presentations must be placed on one machine or there is a need to swap between the presenters' machines. To bring the display content of a computer to a projector, the most common ways are to use a cable that connects the display adapter of the graphics card to the
- 10 video input of the projector [method 1] or to use a software that captures the display contents and sends it over a wired or wireless network to a remote base unit connected to the projector [method 2]. This is often called "remote desktop" and is mostly used for remote administration or remote IT assistance purposes.
- 15 Less common but also practiced methods are to use a special device connected to the display adapter of the graphics card, that captures, encodes and streams the display content over a wired or wireless network [method 3].

- Method 1 has several practical problems and disadvantages. In meetings where people
- 20 want to contribute content from their own computers, e.g. to project images on a display, typically a video cable such as a VGA cable is used to connect each PC one at a time to the projector. This is not only not scalable but also can be and often is quite a cumbersome process that typically wastes valuable meeting time and takes the dynamism out of the meeting. Connection can be made more difficult and time
- 25 consuming for example if the computer has to be rebooted for it to detect the projector or when the format of the PC differs from the format of the projector. In addition changing format can leave the computer with a new format that is not compatible with its own screen so that on reboot of the PC alone, nothing is displayed on the computer screen. Without a visible screen image the necessary re-configuration can be difficult.
- 30 These issues are aggravated by a number of elements:

- The use of many different video adapters, such as VGA, DVI-A, DVI-D, DVI-I, DP, HDMI, thunderbolt,...

- Reach depends on cable length: too long leaves a tangled cable “salad” in the meeting room, too short reduces flexibility, often necessitating people to move around in the meeting room when they want to present something.
 - Cable connection is either point to point or requires tedious and extensive cabling and the use of complex and expensive video switches.
 - It is often difficult and time consuming to find the right display resolution and refresh rate that both the computer and the display or projector support.
 - Known technical solutions are expensive and not 100% reliable.
- 10 Method 2 also has many drawbacks. If the connection is made to a corporate LAN there is a danger of virus, malware or spyware transfer in either direction, there is danger of copying of confidential information, and there is the difficulty of making the connection, e.g. entry of a user code and password, as well the administration of such passwords and user codes. In business contexts, visitors to meeting rooms typically do
- 15 find technical difficulty with such means to connect to a central projector or display in the meeting room.

Additional problems can occur with firewalls and proxies. Typically a visitor to a meeting will bring a computer such as a laptop that is set up for a different corporate

20 networking environment and hence has different or incompatible networking settings. The setting up of a firewall can be complicated and if this is not done correctly, telecommunication software that has to pass through a firewall may be blocked. In order to solve problems associated with firewalls it may be necessary to open ports or identify or even add programs in an exception list. If, besides a network (hardware)

25 firewall and an operating system firewall, there is any software based third-party firewall like Zonealarm, CA Internet Security Suite or McAfee Firewall, then it is necessary to follow that software developer’s documentation to place programs on a safe list or adding exceptions to the firewall rules. Such activity is beyond the usual user. Fussing with computer settings, or having to call for IT support wastes valuable

30 meeting time and takes the dynamism out of the meeting.

The advantage of method 3 is that the computer does not need to use its own

processing power to bring the display content in a form that is easily transported over a network. This advantage becomes less relevant as computers grow in processing power. A drawback of method 3 is that the same problems often encountered with method 1 of connecting to the display adapter remain. Another drawback is that the
5 special device referred to requires significant processing power, which means that this device will consume much power and will require a separate power supply, be relatively big and certainly be relatively expensive.

An alternative method in the making today is to use the well known USB interface of
10 the computer for extracting the display content of the computer. US 2009/0198839 discloses such a pluggable cable arrangement. US 2011/0115689 discloses a similar USB solution for wireless connection to a projector. Accordingly connecting a projector to a computer using the standard USB port might become commonplace with time. However, this usually requires special drivers and even special hardware in the
15 computer. Connecting a projector to a computer using the standard USB port hence might become commonplace – but even when that happens there will be a mix of new and legacy machines for several years.

20

Conclusion

The following problems remain for holding a face-to-face meeting using advanced electronic tools at the present time:

- Complexity of the networking infrastructure.
- 25 - High demands on technical expertise of users in current systems that are supposed to be designed to support everyday use by the non-expert user.
- Barriers to the use of complicated technology in meetings.
- Great variety of possible collaborative software solutions – none of which seems to solve the fundamental problems of holding successful meetings.
- 30 - Meetings being boring or annoying for members of the meeting.
- Complexity of firewalls and other security measures employed in corporate networks.
- Lack of, or restriction of participation by members of a meeting.

- Time taken to prepare presentations for meetings.
- Need to record events in the proper time sequence at meetings without burdening a meeting more than necessary.

Although some tools solve some of these problems effectively, no electronic meeting
5 tool solves all of them.

Summary of the invention

An object of the present invention is to provide network solutions including electronic
tools for meetings as well as devices for providing connection to a communications
10 network, to methods of operating the network, methods of displaying media content as
well as software for performing any of these methods or for implementing such
systems. There is also a need to capture what is actually shown or said in a meeting
and not merely what might have been shown or said.

15 An aspect the present invention provides an electronic meeting tool for communicating
arbitrary media content from users at a meeting comprising:

a node configuration means adapted to operate a display node of a communications
network, the display node being coupled to a first display, the node configuration
means being adapted to receive user selected arbitrary media content and to control
20 display of the user selected arbitrary media content on the first display; and
at least one peripheral device adapted to communicate the user selected arbitrary
media content via the communications network, wherein the peripheral device is a
connection unit comprising:

- 25 (a) a connector adapted to couple to a port of a processing device having a
second display, a memory and an operating system; and
(b) a transmitter for communicating with the communications network,

a program adapted to be loaded onto the processing device and to run on the operating
30 system of the processing device, said program being adapted to obtain user selected
arbitrary media content, said program leaving a zero footprint on termination, and
an input device to allow the user to carry out a user action that triggers transfer of said
user selected arbitrary media content to said transmitter through said port.

Obtaining user selected arbitrary media content is preferably not obtained by application sharing but by the process of screen scrapping. Although software packages that provide screen scraping require installation on the target device, or at least require the installation of dedicated and/or custom drivers, embodiments of the present invention use software stored on the peripheral device which allows screen scraping when run on the processing device but leaves a zero footprint when terminated. Embodiments of the present invention can screen scrape full HD videos at 20fps without requiring any installation of a program on the processing device nor requiring configuring the processing device such as a PC that they run on for the connectivity to the network hence meeting "zero footprint" requirements.

The program adapted to be loaded onto the processing device and to run on the operating system of the processing device and being adapted to obtain user selected arbitrary media content can be stored on the peripheral device. The transmitter can be a wireless transmitter or transceiver. The peripheral device can be a plug-and-play device. The program can be adapted to screen scrape content of the second display.

The input device can be physical actuator coupled to the peripheral device. The physical actuator preferably has a surface area of between 100 and 14,400 square mm. Alternatively, the input device can be a key displayed on the second display. The key displayed on the second display can be one not screen scraped by the program.

On the peripheral device a mass storage device is provided that stores the software to be run on the processing device. The mass storage device can be logically closed once the software has been read and loaded and is running from RAM in the processing device. Also provided on the peripheral device is a further device such as an HID (human interface device) to capture user input and provide user feedback. In embodiments of the present invention, the peripheral device contains multiple internal logical devices that are combined:

An HID (human interface device) used for capturing user input (e.g. following a user action such as pressing or activating a button) and providing user feedback, e.g. by an optical indicator such as a light ring around the button e.g. an LED ring,

for streaming the screen scraped video content to the network and hence to a base unit and a display,

A mass storage device used to store the application,

5 An audio device that acts as a virtual sound card to a client PC over USB, using a generic driver such as a UAC1 or UAC2 device driver.

Embodiments of the present invention are not limited to application sharing but make use of screen scraping which is able to capture all material in a neutral manner rather than being limited by proprietary applications. Further the screen scraper application is
10 zero footprint on termination rather than being fully installed on the processing device.

Embodiments of the present invention can provide arbitrary "full content" to the meeting room and participants can display in real-time,

The real-time content is shown on a central display rather than being broadcast to individual participants or archived.

15 Embodiments of the present invention "auto compose" arbitrary user data on a central display or screen so that full real-time content that is provided by multiple meeting participants who intentionally share this content in order to make the meeting more effective and efficient,

Embodiments of the present invention implement a principle of "democratic screen
20 sharing", in which the meeting participants decide themselves on a peer-to-peer basis which content to share when and where. In particular in some embodiments a participant can obtain unilateral access to the display device, i.e. without agreement of other participants. Peer-to-peer data sharing differs from systems in which the content to be displayed is determined by a presenter or meeting director. The user determines
25 where his content is routed to, and can do so without any software configuration on the user processing device.

Another aspect the present invention provides a method for connecting a processing device to a communications network, the processing device having a memory, a
30 display and an operating system with at least one pre-installed generic driver providing a generic communications protocol for communication between processing device and a standard class of peripheral devices, the method comprising the steps of:

a) coupling a peripheral device to the processing device, the peripheral device having a

transceiver;

b) setting up, by means of the pre-installed generic driver of the operating system, a means for communication between the peripheral device and the processing device;

5 c) coupling the processing device to a communications network via the peripheral device;

d) routing screen scraped data between the processing device and the communication network via the means for communication, wherein the generic communication protocol is used for transferring the screen scraped data between the processing device
10 and the peripheral device.

The routing of the screen scraped data can be to a defined network node such as a display node without user entry of configuration details. Thus the routing can be dedicated to a specific network node such as a display node, base station etc. This is
15 achieved by pairing of the peripheral device to the relevant node before the communication starts.

In accordance with embodiments of the present invention users start an application from the peripheral device such as a USB dongle, thus making the connection in a 3
20 step process: (1) connect, e.g. plug in the peripheral device to the processing device, (2) start the screen scraping application, (3) perform a user action such as click on a button on the peripheral device to go allow content to be displayed on the central screen or display. To achieve step 2 Autorun or AutoPlay can be used with some Windows operating systems, but there are many different variants based on the OS
25 version and which patches have been installed. Furthermore, this mechanism is generally considered a security hazard, which is why most IT departments will disable Autorun/Autoplay. Other OS providers have disabled this function, e.g. Apple removed a similar functionality entirely from its OS/X since Snow Leopard.

30 In an embodiment of the present invention a very small service - also called daemon on some OS's - is provided that requires installation on the processing device such as a laptop. This service is pre-installed on the processing device. The installation is required only once on every processing device such as a laptop. The role of this is to

provide a permanently running service that continuously monitors if a peripheral device according to the present invention has been offered up for connection to the processing device. When such a peripheral device is connected, the service will detect this and start the client application software residing in the mass storage area of the peripheral device. Once the service is installed, connectivity with the peripheral device becomes a 2 step process: connect, e.g. plug in the peripheral device to the processing device, and (2) perform a user action such as click on a button on the peripheral device to allow content to be displayed on the central screen or display. The application loaded from the processing device still leaves a zero footprint on termination

10

Step b) can comprise presenting the peripheral device to the processing device as a human interface device and wherein the pre-installed generic driver is a human interface device driver.

15 Alternatively or additionally step b) can comprise presenting the peripheral device to the processing device as a mass storage device and wherein the pre-installed generic driver is a mass storage device driver.

Alternatively, or additionally step b) comprises presenting the peripheral device to the processing device as a composite device and wherein pre-installed generic drivers drive different device interfaces independently.

20

A client application can be stored on the peripheral device which when run on the processing device obtains the screen scraped data. Such a client application can be a portable application and can leave a zero footprint on termination.

25

In another aspect the present invention provides a peripheral device for providing communication connectivity to a processing device which is provided with memory, a display and an operating system with at least one pre-installed generic driver providing a generic communication protocol for communication between the processing device and a standard class of peripheral devices, the peripheral device comprising a memory in which executable software code is stored for execution on the processing device, said executable software code comprising:

30

a first software code portion for setting up, by means of the pre-installed generic driver of the operating system, a means for communication between the peripheral device and the processing device;

a second software code portion for connecting the processing device to a

5 communications network via the peripheral device, the peripheral device having a transceiver;

a third software code portion for screen scraping data from the processing device; and

a fourth software code for routing screen scraped data between the processing device and the communications network over the means for communication; wherein the first

10 software code portion is adapted to use the generic communication protocol for transferring the screen scraped data between the processing device and the peripheral device.

The first software code portion can be adapted to present the peripheral device to the

15 processing device as a human interface device and wherein the pre-installed generic driver is a human interface device driver. The first software code portion can be adapted to present the peripheral device to the processing device as a mass storage device and wherein the pre-installed generic driver is a mass storage device driver.

The first software code portion can be adapted to present the peripheral device to the

20 processing device as a composite device and wherein pre-installed generic drivers drive different device interfaces independently.

The executable software code can comprise fifth code for providing a means for connecting to the communications network including a base node. The third code can

25 be for providing means for capturing video frame buffers of the processing device.

The executable software code can comprise sixth code for providing a means for encoding, compressing and optionally encrypting the screen scraped data and sending the screen scraped data the communication network. The executable software code can

30 comprise seventh code for providing a means for handling the peripheral device. The executable software code can comprise eighth code for providing means for initiating connection to the base node. The executable software code can comprise ninth code for receiving inputs from an input device on the peripheral device. The executable

software code can comprise tenth code for providing a means for sending state changes to the visual indicator on the peripheral device. The executable software code can comprise eleventh code for providing a means for presenting to the user a GUI. The executable software code can comprise twelfth code for presenting a GUI for
5 administration of the said executable software code when executed as a portable application. The executable software code can comprise thirteenth code for providing a means for displaying and activating a key on the display of the client processing device for allowing a user to input the start the transfer of data from the processing device to the base node.

10

In another aspect the present invention provides a peripheral device for providing communication connectivity to a processing device which is provided with memory, a display and an operating system with at least one pre-installed generic driver providing a generic communication protocol for communication between the processing device
15 and a standard class of peripheral devices, the peripheral device comprising a memory in which executable software code is stored for execution on the processing device, said executable software code comprising:

a first software code portion for setting up, by means of the pre-installed generic driver of the operating system, a means for communication between the peripheral device
20 and the processing device;

a second software code portion for connecting the processing device to a communications network via the peripheral device, the peripheral device having a transceiver; and

a third processing software code for routing data between the processing device and
25 the communications network over the means for communication; wherein the first software code portion is adapted to use the generic communication protocol for transferring the data between the processing device and the peripheral device, and an input device coupled to the peripheral device, the input device being adapted to react to a user action to trigger the transfer of the data from the processing device to
30 the peripheral device.

The first software code portion can be adapted to present the peripheral device to the processing device as a human interface device and wherein the pre-installed generic driver is a human interface device driver. The first software code portion can be

adapted to present the peripheral device to the processing device as a mass storage device and wherein the pre-installed generic driver is a mass storage device driver. The first software code portion can be adapted to present the peripheral device to the processing device as a composite device and wherein pre-installed generic drivers
5 drive different device interfaces independently.

The input device is preferably a physical actuator coupled to the peripheral device. The physical actuator preferably has a surface area of between 100 and 14,400 square mm. The input device can be for example a key for display on the display. The
10 executable software code can comprise fourth code for providing a means for connecting to the communications network including a base node. The executable software code can comprise fifth code for providing a means for capturing video frame buffers of the processing device. The executable software code can comprise sixth code for providing a means for encoding, compressing and optionally encrypting the
15 video frames and sending them over a secure link to the base node. The executable software code can comprise seventh code for providing a means for handling the peripheral device. The executable software code can comprise eighth code for providing a means for initiating connection to the base node. The executable software code can comprises ninth code for receive inputs from an input device on the
20 peripheral device. The executable software code can comprise tenth code for providing a means for sending state changes to the visual indicator on the peripheral device. The executable software code can comprise eleventh code for providing a means for presenting the user a GUI. The executable software code can comprise twelfth code for presenting GUI for administration of the executable software code when executed
25 as a portable application. The executable software code can comprise thirteenth code for providing a means for displaying and activating a key on the display of the processing device for allowing a user input to start the transfer of data from the processing device to the base node.

30 In another aspect of the invention a peripheral device is provided for providing communication connectivity to a processing device which is provided with memory, a display and an operating system with at least one pre-installed generic driver providing a generic communication protocol for communication between the processing device

and a standard class of peripheral devices, the peripheral device comprising a memory in which executable software code is stored for execution on the processing device, said executable software code comprising:

- 5 a first software code portion for setting up, by means of the pre-installed generic driver of the operating system, a means for communication between the peripheral device and the processing device;
- a second software code portion for connecting the processing device to a communications network via the peripheral device, the peripheral device having a transceiver;
- 10 a third software code portion for receiving media content from the network and for displaying the media content on the display in accordance with a set of rules; wherein the first software code portion is adapted to use the generic communication protocol for transferring the media content between the peripheral device and the processing device.

15

The executable software code can comprise fourth code for providing a means for correctly configuring a receiver as an access point. The executable software code can comprise fifth code for providing a means for listening for output of connection units trying to connect on a specific port. The executable software code can comprise sixth

20 code for providing a means for a GUI for administration purposes. The executable software code can comprise seventh code for providing a means for publishing its presence over the network using the zeroconf protocol. The executable software code can comprise eighth code for providing a means for accepting and installing software updates. The executable software code can comprise ninth code for providing a means

25 for providing facilities for pairing of connection units to the processing device. The executable software code can comprise tenth code for providing a means for auto-composing of different incoming arbitrary media streams and rendering of composited image on display. The executable software code can comprise eleventh code for providing a means for receiving, decrypting and decoding incoming arbitrary media

30 content. The executable software code can comprise twelfth code for scaling of incoming arbitrary media streams. The executable software code can comprise thirteenth code for providing a means for displaying incoming arbitrary media content in accordance with a set of rules.

- The present invention also provides a method for communicating arbitrary media content from users at a meeting comprising:
- operating a display node of a communications network, the display node being
- 5 coupled to a first display, to receive user selected arbitrary media content and to control display of the user selected arbitrary media content on the first display; and connecting a peripheral device to a port of a processing device and communicating the user selected arbitrary media content via the communications network,
- loading a program onto the processing device and running the program on the
- 10 operating system of the processing device to obtain user selected arbitrary media content, said program leaving a zero footprint on termination, and triggering transfer of said user selected arbitrary media content to said transmitter through said port after a user action on an input device.
- 15 The present invention also provides a peripheral device comprising:
- a base
- a connector for connection to a plug and play port of a host processing device,
- a flexible connection between the base and the connector for transferring data signals and power,
- 20 an actuator on the base for actuating a signal and for transferring the signal to the connector for transfer to the port, wherein the base has electronics comprising permanent storage for storing a portable application, a processing engine, a transceiver and a visual indicator.
- 25 The present invention also provides a method for providing communication connectivity from a processing device,
- setting up a communications network between a base node of the communications network and a peripheral device coupled to the processing device;
- transferring media content between the processing device and the peripheral device,
- 30 transmitting the media content from the peripheral device to the communications network,
- receiving media content from the communications network at the base node and displaying the media content on a display in accordance with a set of rules.

Any of the above software code stored on a non-transitory storage medium.

Definitions

5

The term “unilateral electronic access to the display device” by a participant, means that the displaying process is obtained by the action of only one participant involved in the meeting, without requiring the agreement of another or the others. The term “unilateral” implies that the data for display is allowed to override or replace any data
10 displayed on the screen by the same or another participant of the meeting.

"Plug and play" is a term used to describe the characteristic of a computer bus, or device specification, which facilitates the discovery of a hardware component in a system, without the need for physical device configuration, or user intervention in
15 resolving resource conflicts. Plug and play devices can be added to a bus of a computing system (while running or when shut down), and the newly added device and possibly the rest of the computing system is automatically configured to make the newly added device work, both from hardware and from software perspective.

20 Plug and play interfaces include for example (not an exhaustive list): Firewire (IEEE-1394), PCI, Mini PCI, PCI Express, Mini PCI Express, PCMCIA, PC Card, Universal Serial Bus (USB), SDIO cards.

"Auto-configuration" is the automatic configuration of devices without manual
25 intervention, without setting any switches or jumpers, and without any need for software configuration. An example of auto-configuring devices: USB devices. Examples of auto-configuring protocols: DHCP, Zeroconf, Bonjour.

A plug and play device has auto-configuration software by default to make it plug and
30 play. Example: USB devices are made to be plug and play by including the correct auto-configuration software (e.g. host driver, host stack, application software). Autoconfiguration can also refer to a software alone and is not restricted to a physical device.

"Hot swapping and hot plugging" are terms used to describe the functions of replacing computer system components without shutting down the system. More specifically, hot swapping describes replacing components without significant interruption to the system, while hot plugging describes the addition of components that would expand the system without significant interruption to the operation of the system. A well-known example of this functionality is the Universal Serial Bus (USB) that allows users to add or remove peripheral components such as a mouse, keyboard, or printer. Other examples are eSATA, PCIe, FireWire, for example.

10

A "portable application" (portable app), sometimes also called standalone, is a computer software program designed to run without installation on the target machine. This type of application is stored on a removable storage device such as a CD, USB flash drive, flash card, or floppy disk – storing its program files, configuration information and data on the storage medium alone. It is a program that can be stored on an electronic device such as a USB flash drive, iPod, memory card, portable hard drive or other portable electronic device and runs on a computer or other processing device coupled to the electronic device without making permanent configuration changes to the host computer. All such programs have a zero-footprint, meaning all temporary files, registry entries, and any other changes to the machine exist only while the program is running.

15
20

To be considered a portable application, for purpose of this invention, a software program must:

25

Not require any kind of formal installation onto a computer's permanent storage device to be executed, and can be stored on a removable storage device such as USB flash drive, iPod, memory card, portable hard drive or other portable electronic storage device thus enabling it to be used on multiple computers.

30

Settings are stored with, and can be preferably carried around with, the software (i.e., they are written to the electronic device such as a USB drive). Settings are not stored to the registry or any other central system database of the computer.

Leaves a zero (or near-zero) "footprint" on any PC it is run on after being used. i.e., all

temporary files/registry settings should be either avoided or at least removed once the program has exited, and files created by the user can be saved directly to the same removable media as the application is stored on.

- 5 A portable application does not leave its files or settings on the host computer on which it runs. For example, the application does not write to the Windows registry or store its configuration files (such as an INI file) in the user's profile; instead, it stores its configuration files in the program's directory. Another requirement, since file paths will often differ on changing computers due to variation in Windows drive letter
10 assignments, is the need for applications to store them in a relative format. Preferably, such a program does not require a launcher program to copy necessary settings and files to the host computer when the application starts and move them back to the application's directory when it closes as this may leave a residue on the hard drive in case of power failure.

15

- "Electronic meeting systems" (EMS) need to be distinguished on the one hand from classic groupware, on the other from web conferencing systems. In reality, there is some overlap between minor features of products of the named categories. The main difference from groupware is the intensity of collaboration. EMS should be
20 distinguished from systems with which it is possible to show the contents of an individual computer screen on a remote display with multiple users at the same time.

- "Groupware" supports collaboration within groups where the individual contributions remain identifiable. In contrast, EMS enable the group to cooperatively produce a
25 result for which the group is responsible as a whole. In a business process, groupware and electronic meeting systems complement each other: Groupware supports teams when researching and creating documents in the run up to an EMS session or when implementing the results of such a session.

- 30 "Web conferencing systems" and "electronic meeting systems" complement each other in the online meeting or workshop: EMS extends the web conferencing system by providing interactive tools for producing and documenting group results. On the other hand, "web conferencing systems" complement EMS with the screen sharing and

voice conferencing functionality required in synchronous online meetings and not present in EMS.

"Data conferencing" refers to a communication session among two or more participants sharing computer data in real time. Interaction and presentation devices such as a screen, keyboard, mouse, camera, etc. can be shared. It is a term used to distinguish from video conferencing and audio conferencing. The data can include screen, documents, graphics, drawings and applications that can be seen by the participants of the meeting.

"Application sharing" is an element of remote access, falling under the collaborative software umbrella, that enables two or more users to access a shared application or document from their respective computers simultaneously in real time. Generally, the shared application or document will be running on a host computer, and remote access to the shared content will be provided to other users by the host user. Application sharing should be distinguished from systems in which collaboration on the applications between different users is not possible but the contents of individual computer screens can be projected onto a remote display with multiple users at the same time.

The term "arbitrary media content" refers to the fact that a user may generate, create or select any media content that is appropriate to display. This differs from client voting on, or selecting of media content that is displayed by another in a meeting or presentation. This term refers to client oriented, distributed rights and privileges for the display of content rather than a central presenter providing content which is presented to the members of the meeting.

"Screen scraping" in our sense refers to reading the video frame buffers and processing them, rather than just rendering them on a display. Screen scraping for presentations is described in US2002/0196378 to Slobodin et al which is included herein by reference.

"Auto composition" or "auto layout" refers to the automatic nature in which multiple

graphics/video sources are rendered on a central display, without user intervention and in a way that a user would intuitively expect it to happen.

5 “Wireless” and “wireless communication network” can be any network that does not use cable links between nodes, e.g. uses RF, optical or InfraRed for communication purposes, such as IrDA, diffuse infra-red, WLAN, WiMax, WiFi, WiFi Direct, Bluetooth or any other wireless communication network known to the person skilled in the art such as optical networks like LiFi.

10 “Computer” generally refers to a processing device, i.e. having a processing engine capable of various types of digital processing, such as rendering graphics images for display. A computer can be in the form of a work station, a personal computer, a laptop, a palm top, a PDA, a smartphone, a tablet etc. Generally a computer has memory such as volatile RAM. Non-volatile memory such as a hard disc, optical disk or solid
15 state memory can be included in the computer or can be a peripheral device. Currently most computers are electronic but the term “computer” also include optics based computing devices.

The term "pre-installed generic driver" is intended to mean a driver which is installed
20 on a processing device such as a computer as a standard driver, e.g. is installed with the installation of the operating system. Such a driver is standard for the operating system and can drive a standard class of peripheral devices coupled to or connected to the processing device. The installation of a specific driver for such a peripheral device is not required. Such a generic driver can be a human interface driver (HID) or a mass
25 storage device driver, which has predetermined software components configured for driving mass storage, a CD-ROM, a keyboard etc. or combinations of these. Such devices can be readable and writable computer peripheral memory devices such as USB memory sticks, flash memories, external hard drives, or more.

30 Brief Descriptions of the drawings

Fig. 1a shows a meeting room that can be used with embodiments of the present invention. Fig. 1b shows a combination of a client processing device, a connection

unit, a base node and a display in accordance with an embodiment of the present invention.

Fig 2 shows a screen display in accordance with an embodiment of the present invention.

5 Figs. 3 to 5 show a base node and a peripheral device and a client processing device in accordance with embodiments of the present invention.

Fig 6 shows a display in accordance with an embodiment of the present invention.

Fig. 7 shows a peripheral device in accordance with an embodiment of the present invention.

10 Fig. 8 shows a client processing device in accordance with an embodiment of the present invention.

Fig. 9 shows a further client processing device in accordance with an embodiment of the present invention.

15 Fig. 10 shows an embodiment of a peripheral device in accordance with an embodiment of the present invention.

Detailed Description of the Embodiments of the present Invention

The present invention will be described with respect to particular embodiments and with reference to certain drawings but the invention is not limited thereto but only by
20 the claims. The drawings described are only schematic and are non-limiting.

Furthermore, the terms first, second, third and the like in the description and in the claims, are used for distinguishing between similar elements and not necessarily for describing a sequential or chronological order. The terms are interchangeable under
25 appropriate circumstances and the embodiments of the invention can operate in other sequences than described or illustrated herein.

Moreover, the terms top, bottom, over, under and the like in the description and the claims are used for descriptive purposes and not necessarily for describing relative
30 positions. The terms so used are interchangeable under appropriate circumstances and the embodiments of the invention described herein can operate in other orientations than described or illustrated herein.

The term "comprising", used in the claims, should not be interpreted as being restricted to the means listed thereafter; it does not exclude other elements or steps. It needs to be interpreted as specifying the presence of the stated features, integers, steps or components as referred to, but does not preclude the presence or addition of one or more other features, integers, steps or components, or groups thereof. Thus, the scope of the expression "a device comprising means A and B" should not be limited to devices consisting only of components A and B. It means that with respect to the present invention, the only relevant components of the device are A and B.

Similarly, it is to be noticed that the term "coupled", also used in the description or claims, should not be interpreted as being restricted to direct connections only. Thus, the scope of the expression "a device A coupled to a device B" should not be limited to devices or systems wherein an output of device A is directly connected to an input of device B. It means that there exists a path between an output of A and an input of B which may be a path including other devices or means.

Elements or parts of the described devices may comprise logic encoded in media for performing any kind of information processing. Logic may comprise software encoded in a disk or other computer-readable medium and/or instructions encoded in an application specific integrated circuit (ASIC), field programmable gate array (FPGA), or other processor or hardware.

References to software can encompass any type of programs in any language executable directly or indirectly by a processor.

References to logic, hardware, processor or circuitry can encompass any kind of logic or analog circuitry, integrated to any degree, and not limited to general purpose processors, digital signal processors, ASICs, FPGAs, discrete components or transistor logic gates and so on.

Embodiments of the present invention provide solutions to three major problems with meetings:

- a) the time taken to prepare for a meeting. This is mainly achieved by allowing “on-the-fly” presentation of any displayable information. This information does not have to be linked into any particular presentation software, nor to be compatible with any such presentation software,
- 5 b) the time taken to conduct the meeting using electronic meeting tools. This is achieved by reducing the time to connect computers to the display or projection system.
- c) the time taken to reflect and review and document the meeting afterwards. This is achieved by providing the possibility of recording the course of the meeting in the
10 same time sequence that it was carried out as well as be able to store all data presented and who presented it.

Fig. 1a is a schematic representation of a generic meeting room 30 with a meeting table that can be used with embodiments of the present invention. Participants 37
15 having some form of processing device 31 such as a laptop computer, a tablet, a PDA etc. Each of the processing devices 31 can be a host device and has a first connection unit 47 to which it is coupled. The first connection unit 47 provides access to a network 50 which in this case is a wireless network, but could be a wired network. The network can be a sheared resource network. Each connection unit 47 may be coupled
20 to an input device 48 which will be described in more detail later. A user 37 will typically at a distance from the processing device 37 which is ergonomically satisfactory. This ergonomic boundary is typically an area of about 1000 sq cm to 4000 sq cm. This ergonomic boundary will typically have the user as one side of the boundary and the comfortable reach of the arms will determine an area on the left and
25 right of the processing device which falls within the ergonomic boundary and the far edge of the boundary of the processing device (normally delimited by a display screen) will determine the other side of the ergonomic boundary. The area defined by the ergonomic boundary will overlap or include the processing device 31 itself. The processing device will also have an outer physical boundary. The input device 48 is
30 preferably arranged to operate outside the boundary of the processing device 31 but within the ergonomic boundary. Preferably the input device is arranged to function when it is flat on the table. The input device preferably has an size of activation area of between 1 and 144 square cm.

In other embodiments of the present invention a wireless memory card can be provided to enable a second Wi-Fi link on a processing device such as a laptop or tablet. The wireless memory card stores data and media and fits into the laptop just
5 like a regular SDHC card. The wireless memory card preferably has built-in Wi-Fi that effortlessly transfers data, photos and videos to another device or computer. For instance an Eye-Fi card (www.eye.fi) can be used to enable the latter,

Preferably the network 50 is a local area network, (e.g. a shared resources network) i.e.
10 preferably local to the meeting room for security reasons but the network 50 may have access to other local or wide area networks such as 51 or to a larger corporate network or the internet 43, for example via a router 42. Another node of the network 50 is the base or display node 36. This node 36 may optionally be a wireless access point. The base node 36 may also be a processing device or host computer and may be coupled to
15 a second connection unit 49 that provides access to the network 50 thus linking all of the processing devices 31, 36 together. The connection unit may have an input device as described above. Alternatively, network connections installed on the base node 36 can be used. Audio equipment 46 may be provided, e.g. a telephone that allows other members of the meeting to call in from remote destinations.

20

The display node 36 is coupled to and adapted to allow display of media on some kind of display 44. The display node is in embodiments of the present invention a base node of the communications network 50. The display 44 may be a projector and/or screen, the projector being coupled to the base node 36. A whiteboard 45 can optionally be
25 provided that can be optionally coupled to the display 44 and/or the base node 36, e.g. when the whiteboard can record electronically what is written on it. Optionally, a camera 35 may be provided to record the entries on the whiteboard 45. The camera 35 may have a third connection unit 52 for connecting the camera 35 to the network 50 so that the data from the whiteboard can be recorded and stored or transmitted to other
30 networks via router 42. The connection unit 52 may have an input device 53 as described above for the connection unit 47.

Optional equipment can be cameras 39, 40, 41 for recording the progress of the

meeting. These cameras can be linked by a network 51, e.g. a cable network to the router 42 and/or the base node 36. Another optional item is a microphone or microphones 38 that can be used to transfer audio, e.g. to the processing devices 31 and to loud speakers (not shown) attached to the base node 36 or part of the display 44.

Any or all of the outputs of the processing devices 31, the cameras, the whiteboard, etc. can be recorded and stored digitally, e.g. in node 36 or elsewhere to provide a complete record with correct time sequence.

Summarising the above, the present invention provides an electronic meeting tool for communicating arbitrary media content between different users 37 (with their own processing devices 31, e.g. PC, mobile phone, or tablet) and one display or projector or multiple displays or projectors 44 in the meeting room 30.

Referring to Figs. 1a and 1b embodiments of the present invention comprise a base or display node 36 being a processing device, e.g. a host computer adapted to receive user selected arbitrary media content, the base node 36 being coupled to a central display 44 which can be a fixed format display and/or a projector or similar. The arbitrary media content can be provided from any of the user processing devices 31. The base node 36 can be adapted to display the received user selected arbitrary media content in accordance with a set of rules, e.g. FIFO, automatically, on request or approval, forced to display, in accordance with a priority etc. Optionally the base node 36 is adapted to force display of the received user selected arbitrary media content, i.e. to allow participation in the meeting by an individual user displaying own selected content on display 44 independently of the person who is nominally responsible for giving a presentation or chairing the meeting. Forcing the display can also be considered as a rule. The phrase “unilateral electronic access to the display device” defines this kind of rule as “unilateral” means that the displaying process is obtained by the action of only one participant involved in the meeting, without requiring the agreement of another or the others. The term “unilateral” implies that the data for display is allowed to override or replace any data displayed on the screen by the same or another participant of the meeting. The meeting tool can also be adapted to allow a

priority setting. This means that a user can set a priority setting for the media to be displayed. A priority of “1” for example can be interpreted by the base node as a forced display, a priority “2” can be interpreted by the base node as display as soon as possible, priority “3” can be interpreted by the base node as place in queue and display
5 as the time comes etc. Setting and using priorities for display are also considered to be working to rules. To execute the rules, the base node 36 may have a decision module. The base node 36 may be a host computer having a processing engine such as a microprocessor and a memory. Preferably, the base node 36 is adapted to treat media content passed to the base node 36 from any or all of the connection units 47 in an
10 equal manner. The base node 36 may be adapted to auto compose the media content on the central display 44 connected to it, e.g. from one or more processing devices 31.

An independent aspect of the present invention is at least one connection unit 47, (optionally 49 for receiving or camera connection unit 52) adapted to communicate the
15 user selected arbitrary media content to said base node 36. Preferably the connection units 47 and/or optionally 49 are physical plug-and-play devices. An example of a connection unit is shown schematically in Fig. 10.

The connection unit 47 (or optionally connection unit 52) may be integrated into a user
20 processing device 31, e.g. as an internal peripheral device or may preferably be an external peripheral device comprising a connector adapted to couple to a port of a user processing device 31. The processing device 31 may have a client display, a processing engine such as a microprocessor, a memory and an operating system. The optional connection unit 49 may be integrated into the base node 36, e.g. as an internal
25 peripheral device or may be an external peripheral device comprising a connector adapted to couple to a port of the base node 36. The connection unit 49 may be fully integrated into the base node 36, e.g. is an internal network interface of the base node 36. The base node 36 may have a processing engine such as a microprocessor, a memory and an operating system.

30

In alternative embodiments of the present invention, the peripheral device can be coupled wirelessly to the processing device, and paired with the processing device such as a tablet or laptop through Near-Field Communication (NFC). In other

embodiments of the present invention, the pairing of the peripheral device can be performed additionally by providing means for receiving biometric data such as a microphone (voice) or a camera (face or iris) or a finger swipe (fingerprint) to the peripheral device. Then the peripheral device can be personalized, or paired, by means
5 of voice or face recognition, respectively. The term voice recognition refers to finding the identity of "who" is speaking, rather than what they are saying. Recognizing the speaker by voice recognition can simplify the task of translating speech in systems that have been trained on specific person's voices or it can be used to authenticate or verify the identity of a speaker as part of a security process. "Voice recognition" means
10 "recognizing by voice", something humans do all the time over the phone. As soon as someone familiar says "hello" the listener can identify them by the sound of their voice alone.

The user processing devices 31, the connection units 47, (optionally 49, 52) and the
15 base node 36 co-operate to form a communication network 50 for linking between at least one of the plurality of processing devices 31, 36, 35 and the central display device 44. The communication network 50 is adapted to receive arbitrary media content from at least one of the plurality of processing devices 31 and to transmit the arbitrary media content of at least one of the plurality of processing devices to the
20 central display device 44.

In some embodiments the storage means of the peripheral device can be adapted to record or share information. For instance, the peripheral device can be adapted to further comprise a private communication channel (e.g. to enable chatting), which can
25 communication with a private communication channel of another participant of the meeting.

An independent aspect of the present invention is a portable application 60 adapted to be loaded onto a client processing device 31 and to be run on the operating system of
30 the client processing device 31. The portable application 60 runs as a process on the client processing device 31 that is adapted to deliver an arbitrary media content from the client processing device 31 to the communication network 50 in response to a user action applied to an input device 48, the process leaving a zero footprint on the

processing device 31 on termination. The network 50 can be a shared resource network. Optionally the portable application 60 is stored on each connection unit 47 and optionally 49. Preferably the portable application 60 is adapted to “screen scrape” content of the client display of the client processing device 31. Optionally the portable application 60 when run on a processing device 31 is adapted to “screen scrape” content of the client display of this client processing device 31 and to transmit it via a connection unit 47. Optionally the portable application 60 when run on the processing device is adapted to “screen scrape” content of the client display of the client processing device 31 and to transmit it via a network interface of the processing device 31, for example if the connection unit 47 has no transmitter or it is not functioning.

The connection unit 47 for communicating with said base node 36 has a network interface e.g. comprising a transmitter 62. The transmitter 62 is preferably a transceiver. Optionally the transmitter/receiver can be a wireless transmitter/receiver.

15

The base node 36 for communicating with the connection unit 47 has a receiver 63 which can be included in the connection unit 49 or integrated into the base node 36. The receiver is preferably a transceiver. Optionally the transmitter/receiver can be a wireless transmitter/receiver.

20

The input device 48 allows a user interaction with the connection unit 47. Preferably the input device 48 is physical actuator coupled to the connection unit 47. The user action applied to the input device 48 generates a signal that can trigger transfer of data from the processing device 31 (to which the connection unit 47 is coupled) to the network 50. Preferably the input device 48 has an activating surface that is between 100 and 14,400 square mm. Optionally the input device 48 can be a key displayed on the client display 1 of a client processing device 31. This key can be activated, e.g. by use of a pointing device such as a mouse trigger transfer of data from the processing device 31 to the network 50.

30

The connection unit 47 is preferably provided with a visual indicator 61, e.g. for allowing user feedback from the connection unit 47 of the status of any activity.

The system also can include a server program 64 adapted to be loaded onto the base node 36, said program 64 being adapted to receive arbitrary media content from one or a plurality of client processing devices 31 through said connection units 47, (optionally 49), and to show this plurality of arbitrary media content streams on one or a plurality of displays 44. The server program 64 may be adapted to allow display in accordance with one or more rules, e.g. FIFO, automatically, on request, forced, in accordance with a priority etc. The forcing rule can be described as “unilateral electronic access to the display device” as “unilateral” means that the displaying process is obtained by the action of only one participant involved in the meeting, without requiring the agreement of another or the others. The term “unilateral” implies that the data for display is allowed to override or replace any data displayed on the screen by the same or another participant of the meeting. To execute the rules, the server program 64 may have a decision module.

Preferably, the server program 64 is adapted to treat media content passed to it from any or all of the connection units 47, 52 in an equal manner. The server program 64 may be adapted to auto compose the media content on the central display 44.

The server program 64 may be a portable application adapted to be loaded onto the base node 36 and to be run on the operating system of the base node 36. The portable application 64 runs a process on the base node 36 that is adapted to display an arbitrary media content received from the client processing device 31 via the communication network 50, the process leaving a zero footprint on the base node 36 on termination. Optionally the portable application 64 is stored on each connection unit 49 and optionally 47 and can be installed therefrom.

Meetings in which visual information is presented on a display or projector commonly suffer from a monopoly effect: one single presenter determines the display contents and thereby has a disproportionate power to influence the meeting dynamics and thereby its outcome. Embodiments of the present invention solve this problem by allowing multiple individuals to simultaneously show their information. The present invention provides according to some embodiments a method to override all currently displayed material. In a sense the method of the present invention transforms visual

communication into something akin to talking, i.e. full-duplex and with the option to shout and interrupt.

The system may also include a central display device 44 and optionally a whiteboard
5 45 or other display means such as a printer. The display 44 being adapted to receive
user selected arbitrary media content, and may be adapted to allow display of the
received user selected arbitrary media content in accordance with one or more rules,
e.g. FIFO, automatic, forced, on request or approval, in accordance with a priority etc.
The forcing rule can be described as “unilateral electronic access to the display
10 device” as “unilateral” means that the displaying process is obtained by the action of
only one participant involved in the meeting, without requiring the agreement of
another or the others. The term “unilateral” implies that the data for display is allowed
to override or replace any data displayed on the screen by the same or another
participant of the meeting.

15

Optionally, one of the connection units 47 can be adapted to be a master connection
unit. Such a master connection unit may be adapted to instruct the base node when
media content from a client processing device 31 may be displayed or which of the
processing devices may be allowed to send content for display.

20

In embodiments of the present invention, at least one portable application is used, e.g.
for the client software on a client processing device 31 or optionally on the base node
36. In these embodiments, one of the pre-installed generic drivers of the operating
system on the relevant computer device 31, 36 is exploited for setting up
25 communication from the computer device 31, 36 to the network 50 via the connection
unit 47, (optionally 49). The generic driver is used in connection with the connection
unit 47, (optionally 49) operating as a peripheral device but the use can go beyond that
of the standard class of peripheral devices for which the generic driver is intended. In
some embodiments the connection unit 47, (optionally 49) operated as a peripheral
30 device communicates with the relevant processing device 31, 36 by using a generic
communication protocol provided by the pre-installed generic driver. Pre-installed
USB drivers are examples. Preferably the setting up of the communication of network
50 using connection unit 47, (optionally 49) does not alter or affect the networking

capability of the relevant processing device 31, 36. For example, if a browser is started on the client processing device 31, this browser can use the standard network interfaces on the processing device 31. This means that transfer of data via the connection unit 47 (optionally 49) is independent of transfer of data over the network interfaces of processing device 31 or 36. This has the advantage that each user can carry out processing such as searching on the internet to gather data independently of the transfer of data to be displayed during a meeting, or receive emails etc.

The use of a portable application has the advantage that any modification to settings in the register or generally in the operating system can be avoided, so that upon any form of termination, e.g. disconnecting the electronic device, system crash, no trace is left. This is generally termed "zero footprint".

The present invention has the advantage of scalability. It can provide a display system for use by a plurality of users in meetings. Every user in the meeting thus can have a client processing device 31 for coupling to a connection unit 47. A first user action connects the client processing device 31 to the base node 36, e.g. by inserting a connection unit 47 into the relevant interface connector on the processing device 31, e.g. a USB interface. A second user action comprising activating a button or key on the input device (e.g. by depressing it) then starts the process of transmitting arbitrary media content from the client processing device 31 to the base node 36. This process preferably includes screen scraping data from the processing device. Using screen scraping avoids special programs being installed on the base node 36 to carry out graphical commands sent from the processing device 31. When the base node 36 receives the plurality of arbitrary media content, it can allow auto composition of this media content on the central display connected to it.

In some embodiments, the button or key can be virtual button which is displayed on the screen instead of a button or key on the input device, which for instance can be the peripheral device. Preferably, when the process of transmitting arbitrary media content has been activated, the screen scraping data from the processing device does not scrape the virtual button. The latter can be enable for instance by positioning the virtual button on a second layer which is not scraped.

The present invention will now be described further with reference to certain more specific embodiments.

5 The present invention in some embodiments provides a system and/or a method to which in one aspect can override all currently displayed material when arbitrary material is presented on a display device from more than one source processing devices such as a laptop, PDA, smartphone, computer, tablet etc . The present invention in one aspect controls the display of visual communication and information
10 by a method akin to talking, i.e. full-duplex and with the option to interrupt or to obtain unilateral electronic access to a display device.

One embodiment the present invention can be implemented through a connectable peripheral device e.g. a USB compatible device, such that when the peripheral device
15 is connected to a processing device that is used to provide arbitrary information such as text, video, pictures etc., each individual user with a processing device can to gain access to the display, e.g. screen. By being present at the meeting a user can pair the peripheral device to a processing device by inserting the peripheral device. The user can also pair the peripheral device to a base node or base unit that controls the display
20 in the meeting room and which is connectable to the peripheral device via a communications network such as a wired or wireless communications network. The network is a shared resources communications network as different devices and participants can transmit data over the network. To achieve this, the peripheral device has a transceiver capable of transmitting the arbitrary data from the processing device
25 to the display via the base node. In one option the information displayed on the local display of the processing device is screen scraped and transmitted. To allow this the peripheral device can include a portable application that is able to execute on the processing device leaving a zero-footprint on termination. Although a physically connectable peripheral device is convenient, the peripheral device could also be
30 coupled to the processing device via a wireless connection, e.g. via the Bluetooth protocol.

For meetings with remote participants it is not possible to rely on the same hardware

connectable peripheral device to provide access from a remote location to the display in the meeting room directly. Typically, at home or in a hotel, the participant only has a phone and internet access on a laptop or some other kind of portable computing device. Remote participants lack context (e.g. non-verbal communications) and have
5 less than ideal audio/video connections and consequently suffer from a power-asymmetry. Typically, remote participants also have no way of ‘pushing’ their contents on screen, since the meeting is controlled by a meeting organiser or director who orchestrates the sequence of presentations.

10 One of the key advantages of the present invention is to provide remote collaboration while maintaining a kind of ‘situational awareness’. This means that what you see has a straightforward relationship with your internal mental map. This allows keeping track of multiple information flows and being able to correlate that quickly with any other information, e.g. with a search carried out on the local computing device.

15

In another aspect of the present invention confusion and frustration is avoided by:

1. retaining aspect ratio of any image that is sent from any location to the display in the meeting room or displays in meeting rooms (e.g. a long thing remains a long
20 thing)
2. not overlapping images and/or windows on any of the display devices in the meeting rooms (e.g. you never have to guess or remember what’s hidden)
3. showing the same arrangement of images on each screen (everyone sees the same things and can refer to them), this means that the topological arrangement of
25 images on each screen of multiple screens is the same,
4. maximizing the use of screen real-estate (e.g. the images presented do not have borders containing no useful information), while preferably no allowing overlapping of the images
5. allowing local manipulation of zoom and pan but allowing to return to the
30 default layout of item 3 above
6. arranging the images on each display taking into account the local display characteristics, such as any of resolution, pixel density, aspect ratio,
7. optionally also allowing an ongoing audio connection to be heard by all

participants, e.g. that verbal communications will be used to alter the contents of the screen.

5 With reference to Fig. 2, the base node software (6) running on a base node 36 can be adapted to display on the central display a splash screen (21) showing its readiness to receive arbitrary media content over its receiver. This splash screen (21) can also show instructions on how to use the system, as well as the configuration parameters (see later) to reach the base node 36. These configuration parameters are also shown in a transparent canvas at the bottom of the central display (22).

10

A client processing device 31 that wants to have its arbitrary media content displayed on the central display connected to the base node 36 is connected to a connection unit 47. The portable application 60 will be executed on the client processing device 31 as a host device. A first user interaction creates a connection between the portable
15 application 60 and the base node 36 using the transmitter in the connection unit 47 and the receiver in the base node 36. This user action can be a connection of the connection unit 47 to the processing device 31. A second user interaction, this time on the input device 48, activates screen scraping by the portable application of the arbitrary media content from the client processing device display, which is then sent
20 over the connector unit 47 to the base node.

The base node 36 receives the plurality of arbitrary media content coming from one or more connection units 47, and auto composes this media content for rendering on the central display.

25

The visual indicator 61 on the connection unit 47 indicates to the user and to other participants in the meeting that media content is being sent by that connection unit 47 to the base node 36 for display.

30 Repeating the second user interaction on the input device 48 of a connection unit 47 decouples the media content from that connection unit 47 from the base node 36. The base node 36 removes that media content from the composed image on the central display and recomposes the remaining content on the central display.

The content on the central display/projector is auto arranged as shown in figure 2. When user 1 adds content, his/her display will be scaled to fill the available central display canvas as much as possible, but without affecting the aspect ratio. When user 2
5 adds in, his content is added to the side of the first image. When user 3 adds his content, the arrangement is a suitable one such as triangle wise. Adding user 4, the image becomes a 2 by 2 tiling, which is the maximum available. When an additional user attempts to add content, he will be blocked. When a user initiates action to remove his/her content, his/her media content is removed from the central display and
10 one moves backward in the composition sequence shown in figure 2.

Base node software

The base node software has one or more of the following features:

- 15 - First code for providing a means or a method step for correctly configuring the receiver of the base node.
- Second code for providing a means or a method step for listening for output of connection units trying to connect on a specific port.
- Optionally, third code for providing a means or a method step for a GUI for administration purposes, offered for example over a web interface.
- 20 - Optionally, fourth code for providing a means or a method step for publishing its presence over the network using the zeroconf protocol.
- Optionally, fifth code for providing a means or a method step for accepting and installing software updates of the base node as well as for the portable application software for the connection units.
- 25 - Sixth code for providing a means or a method step for providing facilities for pairing of connection units to the base node.
- Seventh code for providing a means or a method step for auto-composing of different incoming arbitrary media streams and rendering of composited image on display or projector screen.
- 30 - Eighth code for providing a means or a method step for receiving, decrypting and decoding incoming arbitrary media content.
- Optionally ninth code for providing a means or a method step for scaling of incoming arbitrary media streams

- Optionally tenth code for providing a means for displaying incoming arbitrary media content in accordance with a set of one or more rules.

Any of the above code may be stored on a non-transitory machine readable storage
5 medium such as an optical disk, a magnetic disk, magnetic tape, solid state memory,
USB mass storage device etc.

Portable application for the client processing device

- 10 The portable application comprises an algorithm for screen scraping. Screen scraping algorithms include VNC and RDP or similar. The algorithm may include a combination of algorithms such as VNC and RDP that are optimized for different content, e.g. static text or video. The portable application has one or more of the following features:
- 15 - Eleventh code for providing a means or a method step for connecting to a network including the base node.
 - Twelfth code for providing a means or a method step for capturing video frame buffers of the client processing device, i.e. computer (C), also called screen scraping.
 - 20 - Thirteenth code for providing a means or a method step for encoding, compressing and optionally encrypting these video frames and sending them over a secure link to the base node. Only changed areas such as rectangles or triangles of the screen (or any other suitable geometrical shape) need to be transferred, and different types of rectangles or triangles are encoded in
25 different ways (e.g. RLE, JPEG,...) to optimise performance.
 - Fourteenth code for providing a means or a method step for handling the connection unit.
 - Fifteenth code for providing a means or a method step for initiating connection to base node.
 - 30 - Sixteenth code for receive inputs from the input device on the connection unit.
 - Seventeenth code for providing a means or a method step for sending state changes to the visual indicator on the connection unit.
 - Optionally, eighteenth code for providing a means or a method step for

presenting the user a GUI (18).

- Optionally, nineteenth code for presenting GUI for administration of the portable application.
- Optionally, twentieth code for providing a means or a method step for displaying and activating a key on the display of the client processing device for allowing a user input to start the transfer of data from the client device to the base node.

Embodiments of the present invention provide a frame grabber. A frame grabber, known in the prior art, is an electronic device that captures individual, digital still frames from an analog video signal or a digital video stream. It is usually employed as a component of a computer vision system, in which video frames are captured in digital form and then displayed, stored or transmitted in raw or compressed digital form. In recent years, connections via USB, Ethernet and IEEE 1394 ("FireWire") interfaces have become prevalent. The frame grabber of the present invention, enables HDMI or Display Port capture instead via USB. The frame grabber preferably functions as follows:

- Connect to the base unit using a TCP/IP socket interface.
- Capture the video frame buffers of the computer,
- Encode, compress and encrypt these video frames and stream them over a secure link to the base unit. Only changed rectangles of the screen are transferred, and different types of rectangles are encoded in different ways (e.g. RLE, JPEG,...)
- Present the user a GUI

Any of the above code may be stored on a non-transitory machine readable storage medium such as an optical disk, a magnetic disk, magnetic tape, solid state memory, nand Flash, etc.

In this embodiment the portable application stored on the connection unit, and is executed in an execution context on the client processing device. The portable application does not need to be copied to or installed on the computer. It can be executed directly from the connection unit. It will only be copied temporarily into an execution context on the client processing device. There are also no changes in

configuration required or settings in the client processing device. This means that nothing will remain on the client processing device when the connection unit is removed. It also implies that the portable application will run on client processing devices where the user does not have the necessary access rights to install software.

5

The portable application is designed in such a way that

- No specific drivers need to be installed on the client processing device.
- Pre-installed drivers are used, e.g. for classes of peripheral devices.
- It is independent from vendor specific graphics hardware.
- 10 - It runs on at least one and preferably on a variety of different client processing devices, including Windows, Mac OS/X, Linux, Android, iOS and many others.

Advantages

15

The present application has one or more of the following advantages:

- No need for a master role in the meeting
- Standard plug and play connectivity of connection units to base node
- Simple and well known user actions are employed
- 20 - Own networking facilities of client processing devices not blocked
- No configuration changes on the client processing device
- Input devices are easily accessible; e.g. large size
- Program updates of portable application and server program can be performed locally
- 25 - Portable applications are used, no installation, multi-platform, no vendor specifics
- Particular implementation of screen scraping done by portable application avoids vendor specific graphics devices
- Standard drivers are used so no need to install extra drivers
- 30 - No configuration changes on the client processing devices
- Zero footprint applications on client processing devices – nothing to clear up or adjust or reset
- Own networking facilities of client processing devices not blocked

- No configuration changes on the user computers
- Low virus, malware and spyware risk

The portable application may be stored on a non-transitory machine readable storage
5 medium such as an optical disk, a magnetic disk, magnetic tape, solid state memory,
nand Flash etc.

Second Embodiment

10 In the second embodiment, referring to Figs. 2 to 5, the base node is a separate
physical processing device called base unit (B), comprising permanent storage,
memory, a processing engine, a wireless access point (4), a plug and play interface
such as a USB port (11), a graphics display output adapter (5) like
VGA/DP/DVI/HDMI, and optionally an audio output adapter (27). An input device
15 having an actuator such as a button 13 and a visual indicator 14 are optional.

The connection unit is a physical device in the form of an external peripheral device
(shown in the drawings as a “dongle” D) comprising permanent storage storing the
portable application (7) and configuration parameters (12), memory, a processing
20 engine (e.g. CPU, FPGA), a wireless transmitter such as WiFi (3) or other wireless
transmitters such as LiFi, a plug and play interface such as a USB interface (2), a
button as input device (9), an LED ring as visual indicator (10). The portable
application is stored on the peripheral device (7).

25 The client processing device is host device, for example a computer or laptop
comprising a display, a plug and play interface such as a USB port (2), memory, and a
processing engine such as a microprocessor.

The system thus comprises

- 30
- an external peripheral device (D) that has a plug and play interface such as a
USB interface (2) on one end and a communications interface such as a
wireless interface configured as client (3) on the other end.
 - a base unit (B) that has a communications interface such as a wireless interface

configured as access point on one end (4) and a video card adapter (5) like VGA, DVI, DP or HDMI on the other end.

- a portable application (7) stored on the peripheral device (D) but executed on the client processing device (C)
- 5 - a base node software (6) stored and executed on the base unit (B)

The external peripheral device (D) also preferably has any one or any combination of:

- a large button as actuator for the input device (9) allowing user interaction with the peripheral device. The button preferably has an actuation surface area of between
10 100 and 14,400 square mm.
- visual indication such as a LED (10) allowing user feedback from the peripheral device. The user feedback can be in the form of a light ring.

15 An advantage of embodiments of the present invention is to provide data transfer to the peripheral device via a peripheral interface such as a USB interface on any processing device such as a computer in a manner that is largely operating system independent and without leaving a footprint (Zero-Footprint). Installation of drivers and/or applications onto such a processing device as a computer is not necessary
20 wherever pre-installed generic drivers are present. Administrator rights on the processing device such as a computer are preferably not necessary. To avoid the need for administrator rights, embodiments of the present invention use other peripheral device pre-installed drivers such as USB class drivers supported without any extra installation. Embodiments of the present invention route at least screen scraped data
25 presented by client software running on the processing device for transfer to a communications network via a peripheral device such as a USB device. This bypasses any network interface of the processing device C (and hence many firewalls) but only for the specific client software. Other applications are not affected and can make use of the standard network interfaces, i.e. packets from/to the TCP/IP stack are
30 transferred to a network device as normal. The client software is launched from the peripheral device such as a USB composite device or storage device as a portable application, which can avoid that any traces are left on the host OS.

Basic usage scenario of the second embodiment

The base node software (6) displays on the projector a splash screen – (21) in figure 5 - showing its readiness to receive arbitrary media content over its receiver (4). This
5 splash screen (21) also shows instructions on how to use the system, as well as the configuration parameters (see later) to reach the base node. These configuration parameters can also be shown in a transparent canvas at the bottom of the central display (22).

10 To avoid user interaction for the configuration of the connection between peripheral device and base unit, a pairing process is used. This pairing process provides the peripheral device, i.e. the connection unit with networks parameters needed to set up the local network. As an example, the peripheral device can be briefly plugged into the
USB port (11) of the base unit (B). The base unit then optionally does a software
15 validity check, optionally does a software update of the portable application stored on the peripheral device, and writes the connection parameters on the peripheral device (D) required for the peripheral device and base unit to find each other to the permanent storage (8). For example, when using WiFi, this could be the SSID, WEP/WPA2 keys and IP address and port number of the base unit's receiver, as well as the port number
20 used by the base node software, but not all of these are necessarily needed to be exchanged.

A client processing device that wants to have its arbitrary media content displayed on the central display connected to the base node (5) connects a peripheral device (D) to
25 its USB port via (2). The peripheral device presents itself to the computer over interface (2) as a composite device comprising a mass storage device and a keypad. This has the major advantage that no specific driver is required, since all these devices are natively supported in every personal computer system that has a USB port. If autorun is enabled, then the computer will automatically execute the client software
30 (7) stored in mass storage (8) on the peripheral device. The first user interaction mentioned in the general case is then just the connection of the peripheral device to the USB port. If security measures disabled auto-run, the user needs to explore the mass storage on the mass storage of the peripheral device and start the portable application

manually.

The portable application will use the wireless, e.g. WiFi or LiFi interface of the peripheral device (3) to connect to the correct base node. To know the right base unit
5 to connect to, the configuration parameters needed to make this connection are stored in the database (12) on the mass storage device (8) during the pairing process described earlier.

Once the connection is made, the peripheral device goes into connected mode. This
10 means that there is now at least one channel from the peripheral device to the base unit. The content is not shown yet. The LED (10) on the peripheral device now turns white to give a visual indication of this new state.

When the user at the computer (C) wants to show her content, she presses the button
15 (9). When the button was previously in state “connected” (see figure 6), it will check the state of the base unit (P). If the base unit is not in state “full”, the peripheral device will send the screen scraped arbitrary media content to the base unit (B), which will add the media content to the composition on the central display. The peripheral device LED (10) now turns red to indicate “showing” state (figure 6).

20

The button (9) acts as a toggle. When the user presses the button again, that computer displays content will be removed from the projector. The LED (10) goes back to white.

25 Use of the auto-run feature is optional if possible and enabled on the computer (C) to start the client software (7) as soon as the peripheral device is plugged in. On Windows for example, this means mounting the peripheral device as a mass storage device and using the autorun.inf file stored on the peripheral device.

30 In many cases however, this auto-run feature will be disabled for security reasons. In that case, we will, if possible and enabled on the computer (C), use the auto-play feature to show the logo of the connected peripheral device on the desktop of the computer. The user then needs to double click on that logo to start the client software.

If the auto-play feature as described above is also not possible or enabled, the user must browse to the file system of the connected peripheral device and start the application manually. This means double clicking the client.exe file on Windows, client.app on Mac OS/X or tapping the appropriate application icon on a tablet or any
5 mobile device with touch screen.

Third Embodiment: Portable application stored on standard solid state memory such as a USB stick.

10 In the third embodiment, the portable application is stored on a solid state memory such as a regular USB memory stick (figure 7).

With a solid state memory such as a regular USB memory stick, there is no input device, visual indicator or transmitter of the kinds described above for the connection unit. This
15 means that the system needs to:

- Use the transmitter/receiver from the client processing device.
- Use as input device a key or button on the client processing device like a physical key on the keyboard, a special mouse press, a button area on a touch screen, a button displayed on the screen to be clicked on with a mouse pointer.
- 20 - Present the visual indicator on the client processing device's display.

The client processing device then looks like figure 8.

This embodiment provides a peripheral interface such as the USB interface on any
25 processing device acting as a host device such as a computer in a manner that is largely operating system independent. Installation of drivers and/or applications onto such a processing device as a computer is not necessary wherever pre-installed generic drivers are present. Administrator rights on the processing device such as a computer are preferably not necessary. To avoid the need for administrator rights, this embodiment uses other
30 peripheral device pre-installed drivers such as USB class drivers supported without any extra installation. This embodiment of the present invention routes at least screen scraped data presented by client software running on the processing device for transfer to a communications network via a network connection of the processing device. The client

software is launched from the peripheral device such as the USB device as a portable application.

The first user operation then comprises:

- 5 - plugging in the solid state device such as a USB memory stick,
- starting the portable application (if autorun is disabled)
- configuring the transmitter, such as the wired or wireless network interface, on the client processing device to connect to the correct base node, using the configuration parameters (22) shown on the central display
- 10 - triggering the connection of the portable application with the base node, for example by interacting with an element on the GUI (18) of the portable application presented on the display of the client processing device.

Presenting visual feedback on user actions is in this embodiment also done using elements
15 in the GUI of the display of the client operating device.

In this embodiment, the advantage of zero footprint is partly realized by the portable application in the sense that no software is installed on or copied to the client operating device, but there is a configuration change needed to connect the transmitter of the client
20 operating device with the base node, which needs to be undone afterwards.

Optionally, the portable application can make the configuration changes to the transmitter for the user in the background.

25 Advantages lost in this embodiment

- Partial loss of zero footprint nature of portable application
- More complex first user interaction
- More expertise required from user
- GUI needed on client operating device display, which is possibly also shown on
30 central display
- Need to find free key on client operating device when using physical key for second user action
- Network interface is blocked from other uses by portable application

Optionally, the last point can be avoided by using the base unit as a gateway to the network that the client operating device wanted to connect to through its own interface.

Advantages are:

- 5 - tight control of user connectivity to corporate network through settings on the base unit
 - keep network connectivity intact even when transmitter is now also used for display purposes
- 10 Disadvantage is a higher vulnerability of the system because the display connection is now possible a doorway into the corporate network.

What remains as advantages are

- the availability of a physical medium to distribute the portable application to users
- 15 - no need to install or copy software to client operating device
- easy way to maintain software updates on the connection units (here: memory sticks) via the base unit
- possibility to write configuration data on the connection unit by the base unit, for example in the form of a configuration profile that can be read and used by the
- 20 client operating device

Fourth Embodiment: Software only client installed on the client processing device.

25 This embodiment is similar to the third embodiment, with as only difference that the software is copied on the client operating device (figure 9). In this case, no plug and play port such as a USB port is required on the client operating device.

This embodiment will typically be used for tablet PC's and mobile devices. In that case

- there is often no USB port available
- 30 - application distribution is easy and widely accepted through application stores

Fifth embodiment: Base node software OEM'ed to projector or display equipment

In this embodiment, the base node is not realized as a separate physical box, but integrated

into the processing unit inside a display or projector. All other details are as previously described.

Sixth embodiment

5

In this embodiment, the base node is not realized as a separate physical box, but integrated into the codec of a video conferencing equipment. All other details are as previously described.

10 Seventh embodiment: Remote meeting participant

In this embodiment, one or multiple client operating devices are not in the direct vicinity of the base node but on a remote location.

15 To accommodate this case, the following adaptations are needed:

- further compression and or scaling of the arbitrary media content to allow use of low bandwidth connection
- possibility to communicate connection parameters of the base node to a remote user
- 20 - connectivity of the base node to the WAN network to which the remote user is connected

All other details are as previously described.

25 Eighth embodiment: multiple base nodes

In this embodiment, multiple base nodes are used. This can be done for different purposes:

- connectivity of multiple central displays
- extension of real estate of central display
- 30 - connectivity of base nodes in different remote locations

This provides the advantage that one can present on multiple base units from a single peripheral device. This is useful for a number of cases:

- personal peripheral device: user can have a personal peripheral device that is paired with

multiple meeting rooms that he regularly uses

- use in meeting room with multiple base units each controlling a different display in the same meeting room

- 5 The proposal uses a special variant of the peripheral device called a multi base peripheral device. The multi base peripheral device is equipped with a rotating wheel around the circular central "show me" button. This could be a mechanical rotating multi-position switch or something like the touch wheel on the iPod classic.
- 10 The pairing of this multi-base variant of the peripheral device:
- the rotation wheel is put in the position of the corresponding base unit.
 - the peripheral device is paired to the base node in the regular way
 - the configuration parameters are stored in a permanent storage location; every position of the rotating wheel has a corresponding set of connection parameters (e.g. different rows in
- 15 a table) each corresponding with a particular base

The connection of the peripheral device is as follows:

- multi-base peripheral device X is plugged into a PC
 - rotation wheel on peripheral device X is put in position A
- 20 - peripheral device X reads configuration parameters in position A of its internal memory
- peripheral device X connects to base node A
 - base node A indicates connection of multi-base peripheral device X on central display screen
 - rotation wheel on peripheral device X is put in position B
- 25 - peripheral device X reads configuration parameters in position B of its internal memory
- peripheral device X connects to base node B
 - base node B indicates connection of multi-base peripheral device X on screen
 - continue until correct base is selected with rotation wheel
 - click the peripheral device input device e.g. button to show content on central display of
- 30 base node
- rotating the wheel always first clicks away content from the base of the last position

Ninth embodiment

Fig. 10 shows a peripheral device 47 in accordance with an independent embodiment of the present invention including an input device. This embodiment can be used with any of the embodiments described above.

5 The peripheral device is configured as a connection unit and is a physical device in the form of a connector for a plug and play interface of a user processing device as a host computer such as a USB connection, a flexible data and power connection connected to the connector and a base, the base having an actuator, e.g. a button configured to be an input device with the functions as described above.

10

The base and/or the actuator is preferably large in size, e.g. having a surface area between 100 and 14,400 square mm. The base can be square, rectangular, round, hexagonal, oval, polygonal in shape or any other ergonomically suitable shape. The actuator is preferably round but can be square, rectangular, hexagonal, oval, polygonal in shape etc. there can be
15 more than one actuator on one base.

The length of the flexible data and power connection, e.g. cable is preferably adapted to place the peripheral device (when in its connected in its operating position), especially the base and the actuator, in the region between the boundary of the connected user processing
20 device and the ergonomic boundary as defined above. In addition the flexible data and power connection should be adapted so that the base lies flat on the meeting table independent of the orientation of the connector needed to insert the connector into the plug and play interface.

25 The base preferably includes electronics such as having permanent storage for storing the portable application and the network configuration parameters, memory, a processing engine (e.g. CPU, FPGA), a wireless transmitter/receiver such as for WiFi or LiFi, a plug and play interface such as a USB interface, a LED ring as visual indicator. The visual indicator can be used for the LiFi interface. The portable application can be stored on the
30 peripheral device, i.e. in the base. The visual indicator is for allowing user feedback from the connection unit of the status of any activity.

- Some examples for activation of the actuator which can be used with any of the embodiments of the present invention:

- Sound activated (hand clap, voice recognition, computer sound, music, ...)
- Remote controlled via wireless connected device (IR, Bluetooth, WiFi, ...)
- Light activated
- 5 ○ Pressure activated, e.g. depression with a finger or hand.
- Touch activated
- Proximity ('near-touch' on the actuator or bringing the actuator close to some object)
- Biometric reader such as Fingerprint reader, Iris scanner, DNA analyser
- 10 ○ Keypad, e.g. for entering Keycode e.g. a password

Alternative embodiments

In the above embodiments, once the connection is made between the connection device
15 and a host computer, the peripheral device goes into connected mode. This means that there is at least one channel from the peripheral device to the base node. In accordance with any of the embodiments of the present invention a plurality of channels can be set up between the connection device and the base node. These channels may be logical channels.

20 Some examples for such a multichannel arrangement may include the first and one or more of the additional channels:

- First channel is for the Scraped image stream (XDS)
- Second channel is for GPU commands (OpenGL, DirectX)
- Third channel is for Mouse pointer coordinates (absolute, relative)
- 25 ○ Fourth channel is for Mouse pointer icons
- Fifth channel is for Image data files (JPEG, PNG, GIF, ...)
- Sixth channel is for Multimedia data files or streams (MPEG2, MPEG4, OGG, H.26x, ...)
- Seventh channel is for Audio data files or streams (MP3, MP4, AAC,
30 WMA, ...)
- Eighth channel is for text or Document data files (DOC, DOCX, PPT, PPTX, ODT, ODS, PDF, ...)
- Ninth channel is for transmission of a priority value 1,2, 3... as described above.

In the above embodiments, a particular method of pairing the peripheral device with the base node has been described. Any of the embodiments of the present invention may include other pairing mechanisms of which some examples are given below.

5

- Some examples for pairing

- Plug in the peripheral device, to a generic peripheral device port such as a USB port of the base node or other USB enabled device. Pairing info is transmitted over the generic peripheral interface such as USB.

10

- The Signal strength of the wireless channel to the base node is used to identify which base node is to be used

- The Signal strength of the wireless channel or any other channel. Example is an NFC/RFID transmitter can be provided underneath the meeting room table. Putting the user processing device such as a laptop and the peripheral device plugged in on this table automatically pairs the peripheral device with the base of this meeting room

15

- Manual pairing (e.g. by entering IP address, hostname, wireless ID (like SSID on WiFi)).

What is claimed is

1. An electronic meeting tool for communicating arbitrary media content from users at a meeting comprising:

- 5 a node configuration means adapted to operate a display node of a communications network, the display node being coupled to a first display, the node configuration means being adapted to receive user selected arbitrary media content and to control display of the user selected arbitrary media content on the first display; and
at least one peripheral device adapted to communicate the user selected arbitrary media
10 content via the communications network, wherein the peripheral device is a connection unit comprising:

(c) a connector adapted to couple to a port of a processing device having a second display, a memory and an operating system; and

- 15 (d) a transmitter for communicating with the communications network,

a program adapted to be loaded onto the processing device and to run on the operating system of the processing device, said program being adapted to obtain user selected arbitrary media content, said program leaving a zero footprint on termination, and

- 20 an input device to allow the user to carry out a user action that triggers transfer of said user selected arbitrary media content to said transmitter through said port.

2. The electronic meeting tool of claim 1 wherein the program is stored on the peripheral device.

25

3. The electronic meeting tool of any previous claim wherein the transmitter is a wireless transmitter or transceiver.

4. The electronic meeting tool of any previous claim wherein the peripheral device is a
30 plug-and-play device.

5. The electronic meeting tool of any previous claim wherein the program is adapted to screen scrape content of the second display.

6. The electronic meeting tool of any previous claim wherein the input device is physical actuator coupled to the peripheral device.

5 7. The electronic meeting tool of claim 6 wherein the physical actuator has a surface area of between 100 and 14,400 square mm.

8. The electronic meeting tool of any previous claim wherein the input device is a key displayed on the second display.

10 9. The electronic meeting tool of claim 8 wherein the key displayed on the second display is not screen scraped by the program.

10. A method for connecting a processing device to a communications network, the processing device having a memory, a display and an operating system with at least one
15 pre-installed generic driver providing a generic communications protocol for communication between processing device and a standard class of peripheral devices, the method comprising the steps of:

a) coupling a peripheral device to the processing device, the peripheral device having a transceiver;

20 b) setting up, by means of the pre-installed generic driver of the operating system, a means for communication between the peripheral device and the processing device;

c) coupling the processing device to a communications network via the peripheral device;

d) routing screen scraped data between the processing device and the communication
25 network via the means for communication, wherein the generic communication protocol is used for transferring the screen scraped data between the processing device and the peripheral device.

11. The method of claim 10 wherein Step b) comprises presenting the peripheral device to the processing device as a human interface device and wherein the pre-installed generic
30 driver is a human interface device driver.

12. The method of claim 10 wherein Step b) comprises presenting the peripheral device to the processing device as a mass storage device and wherein the pre-installed generic driver is a mass storage device driver.

13. The method of claim 10 wherein Step b) comprises presenting the peripheral device to the processing device as a composite device and wherein pre-installed generic drivers drive different device interfaces independently.

5

14. The method of any of claims 10 to 13 wherein a client application is stored on the peripheral device which when run on the processing device obtains the screen scraped data.

10 15. The method of claim 14 wherein the client application is a portable application.

16. A peripheral device for providing communication connectivity to a processing device which is provided with memory, a display and an operating system with at least one pre-installed generic driver providing a generic communication protocol for communication
15 between the processing device and a standard class of peripheral devices, the peripheral device comprising a memory in which executable software code is stored for execution on the processing device, said executable software code comprising:

a first software code portion for setting up, by means of the pre-installed generic driver of the operating system, a means for communication between the peripheral device and the
20 processing device;

a second software code portion for connecting the processing device to a communications network via the peripheral device, the peripheral device having a transceiver;

a third software code portion for screen scraping data from the processing device; and

a fourth software code for routing screen scraped data between the processing device and

25 the communications network over the means for communication; wherein the first

software code portion is adapted to use the generic communication protocol for transferring the screen scraped data between the processing device and the peripheral device.

30 17. The peripheral device of claim 16, wherein the first software code portion is adapted to present the peripheral device to the processing device as a human interface device and wherein the pre-installed generic driver is a human interface device driver.

18. The peripheral device of claim 16, wherein the first software code portion is adapted to

present the peripheral device to the processing device as a mass storage device and wherein the pre-installed generic driver is a mass storage device driver.

19. The peripheral device of claim 16, wherein the first software code portion is adapted to
5 present the peripheral device to the processing device as a composite device and wherein pre-installed generic drivers drive different device interfaces independently.

20. The peripheral device of any of the claims 16 to 19 wherein said executable software code comprises fifth code for providing a means for connecting to the communications
10 network including a base node.

21. The peripheral device of any of the claims 16 to 20 wherein said executable software code comprises sixth code for providing means for capturing video frame buffers of the
processing device.

15 22. The peripheral device of any of the claims 16 to 21 wherein said executable software code comprises seventh code for providing a means for encoding, compressing and optionally encrypting the screen scraped data and sending the screen scraped data the communication network.

20 23. The peripheral device of any of the claims 16 to 21 wherein said executable software code comprises eighth code for providing a means for handling the peripheral device.

25 24. The peripheral device of any of the claims 20 to 23 wherein said executable software code comprises ninth code for providing means for initiating connection to the base node.

30 25. The peripheral device of any of the claims 16 to 24 wherein said executable software code comprises tenth code for receiving inputs from an input device on the peripheral device.

26. The peripheral device of any of the claims 16 to 25 wherein said executable software code comprises eleventh code for providing a means for sending state changes to the visual indicator on the peripheral device.

27. The peripheral device of any of the claims 16 to 26 wherein said executable software code comprises Twelfth code for providing a means for presenting to the user a GUI.

5 28. The peripheral device of any of the claims 16 to 27 wherein said executable software code comprises thirteenth code for presenting a GUI for administration of the said executable software code when executed as a portable application.

29. The peripheral device of any of the claims 16 to 28 wherein said executable software
10 code comprises fourteenth code for providing a means for displaying and activating a key on the display of the client processing device for allowing a user to input the start the transfer of data from the processing device to the base node.

30. A peripheral device for providing communication connectivity to a processing device
15 which is provided with memory, a display and an operating system with at least one pre-installed generic driver providing a generic communication protocol for communication between the processing device and a standard class of peripheral devices, the peripheral device comprising a memory in which executable software code is stored for execution on the processing device, said executable software code comprising:
20 a first software code portion for setting up, by means of the pre-installed generic driver of the operating system, a means for communication between the peripheral device and the processing device;
a second software code portion for connecting the processing device to a communications network via the peripheral device, the peripheral device having a transceiver; and
25 a third processing software code for routing data between the processing device and the communications network over the means for communication; wherein the first software code portion is adapted to use the generic communication protocol for transferring the data between the processing device and the peripheral device, and
an input device coupled to the peripheral device, the input device being adapted to react to
30 a user action to trigger the transfer of the data from the processing device to the peripheral device.

31. The peripheral device of claim 30, wherein the first software code portion is adapted to present the peripheral device to the processing device as a human interface device and

wherein the pre-installed generic driver is a human interface device driver.

32. The peripheral device of claim 30, wherein the first software code portion is adapted to present the peripheral device to the processing device as a mass storage device and

5 wherein the pre-installed generic driver is a mass storage device driver.

33. The peripheral device of claim 30, wherein the first software code portion is adapted to present the peripheral device to the processing device as a composite device and wherein pre-installed generic drivers drive different device interfaces independently.

10

34. The peripheral device of any of the claims 30 to 33 wherein the input device is physical actuator coupled to the peripheral device.

35. The peripheral device of claim 34 wherein the physical actuator has a surface area of

15

between 100 and 14,400 square mm.

36. The peripheral device of any of the claims 30 to 35 wherein the input device is a key for display on the display.

20 37. The peripheral device of any of the claims 30 to 36 wherein said executable software code comprises fourth code for providing a means for connecting to the communications network including a base node.

38. The peripheral device of any of the claims 30 to 36 wherein said executable software

25

code comprises fifth code for providing a means for capturing video frame buffers of the processing device.

39. The peripheral device of claim 38 wherein said executable software code comprises sixth code for providing a means for encoding, compressing and optionally encrypting the

30

video frames and sending them over a secure link to the base node.

40. The peripheral device of any of the claims 30 to 39 wherein said executable software code comprises seventh code for providing a means for handling the peripheral device.

41. The peripheral device of claim 39 or 40 wherein said executable software code comprises eighth code for providing a means for initiating connection to the base node.

42. The peripheral device of any of the claims 30 to 41 wherein said executable software
5 code comprises ninth code for receive inputs from an input device on the peripheral device.

43. The peripheral device of any of the claims 30 to 42 wherein said executable software code comprises tenth code for providing a means for sending state changes to the visual
10 indicator on the peripheral device.

44. The peripheral device of any of the claims 30 to 43 wherein said executable software code comprises eleventh code for providing a means for presenting the user a GUI.

15 45. The peripheral device of any of the claims 30 to 44 wherein said executable software code comprises twelfth code for presenting GUI for administration of the executable software code when executed as a portable application.

46. The peripheral device of any of the claims 37 to 45 wherein said executable software
20 code comprises thirteenth code for providing a means for displaying and activating a key on the display of the processing device for allowing a user input to start the transfer of data from the processing device to the base node.

47. A peripheral device for providing communication connectivity to a processing device
25 which is provided with memory, a display and an operating system with at least one pre-installed generic driver providing a generic communication protocol for communication between the processing device and a standard class of peripheral devices, the peripheral device comprising a memory in which executable software code is stored for execution on the processing device, said executable software code comprising:

30 a first software code portion for setting up, by means of the pre-installed generic driver of the operating system, a means for communication between the peripheral device and the processing device;

a second software code portion for connecting the processing device to a communications network via the peripheral device, the peripheral device having a transceiver;

a third software code portion for receiving media content from the network and for displaying the media content on the display in accordance with a set of rules; wherein the first software code portion is adapted to use the generic communication protocol for transferring the media content between the peripheral device and the processing device.

5

48. The peripheral device of claim 47 wherein said executable software code comprises fourth code for providing a means for correctly configuring a receiver as an access point.

49. The peripheral device of claim 47 or 48 wherein said executable software code
10 comprises fifth code for providing a means for listening for output of connection units trying to connect on a specific port.

50. The peripheral device of any of the claims 47 to 49 wherein said executable software code comprises sixth code for providing a means for a GUI for administration purposes.

15

51. The peripheral device of any of the claims 47 to 50 wherein said executable software code comprises seventh code for providing a means for publishing its presence over the network using the zeroconf protocol.

20 52. The peripheral device of any of the claims 47 or 51 wherein said executable software code comprises eighth code for providing a means for accepting and installing software updates.

25 53. The peripheral device of any of the claims 47 or 52 wherein said executable software code comprises ninth code for providing a means for providing facilities for pairing of connection units to the processing device.

54. The peripheral device of any of the claims 47 or 53 wherein said executable software code comprises tenth code for providing a means for auto-composing of different
30 incoming arbitrary media streams and rendering of composited image on display.

55. The peripheral device of any of the claims 47 or 54 wherein said executable software code comprises eleventh code for providing a means for receiving, decrypting and decoding incoming arbitrary media content.

56. The peripheral device of any of the claims 47 or 55 wherein said executable software code comprises twelfth code for scaling of incoming arbitrary media streams.

5 57. The peripheral device of any of the claims 47 or 56 wherein said executable software code comprises thirteenth code for providing a means for displaying incoming arbitrary media content in accordance with a set of rules.

58. A method for communicating arbitrary media content from users at a meeting
10 comprising:
operating a display node of a communications network, the display node being coupled to a first display, to receive user selected arbitrary media content and to control display of the user selected arbitrary media content on the first display; and
connecting a peripheral device to a port of a processing device and communicating the
15 user selected arbitrary media content via the communications network,
loading a program onto the processing device and running the program on the operating system of the processing device to obtain user selected arbitrary media content, said program leaving a zero footprint on termination, and
triggering transfer of said user selected arbitrary media content to said transmitter through
20 said port after a user action on an input device.

59. A peripheral device comprising:
a base
a connector for connection to a plug and play port of a host processing device,
25 a flexible connection between the base and the connector for transferring data signals and power,
an actuator on the base for actuating a signal and for transferring the signal to the connector for transfer to the port, wherein the base has electronics comprising permanent storage for storing a portable application, a processing engine, a transceiver and a visual
30 indicator.

60. A method for providing communication connectivity from a processing device, setting up a communications network between a base node of the communications network and a peripheral device coupled to the processing device;

transferring media content between the processing device and the peripheral device, transmitting the media content from the peripheral device to the communications network, receiving media content from the communications network at the base node and displaying the media content on a display in accordance with a set of rules.

5

61. Any of the above software code stored on a non-transitory storage medium.

30

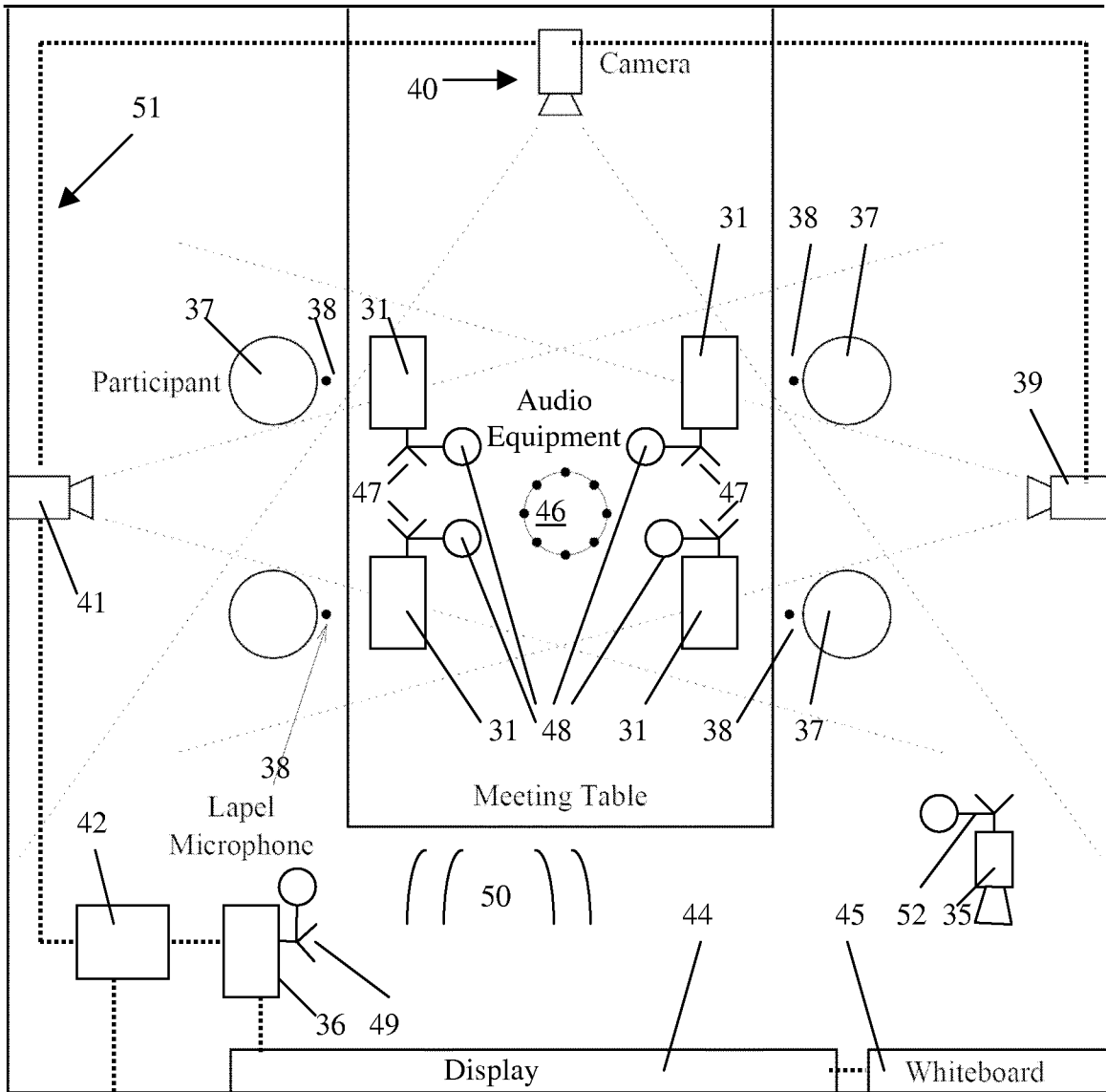

43

Fig. 1a

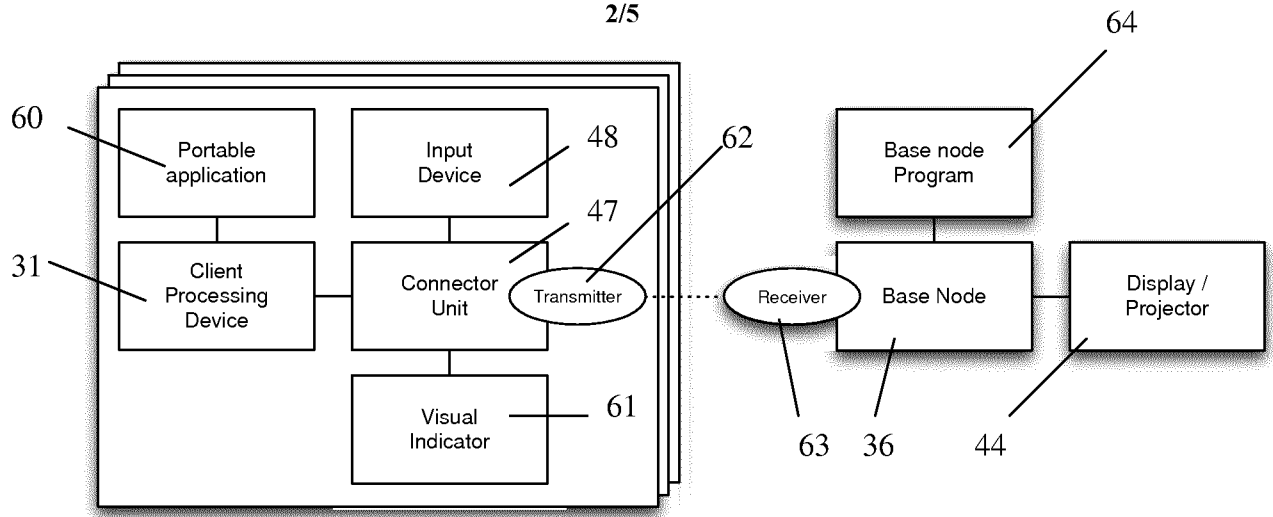

Fig. 1b

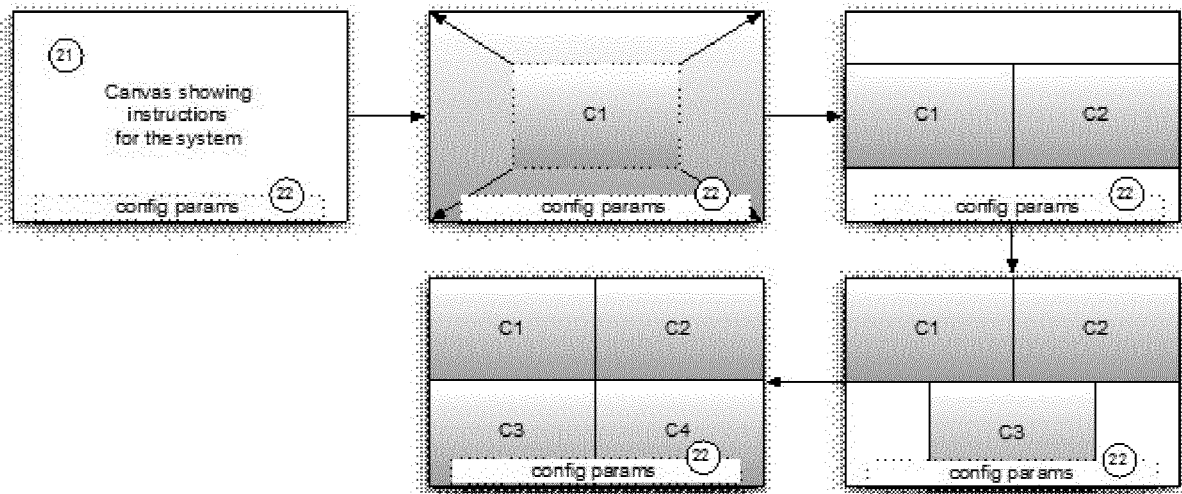

Fig. 2

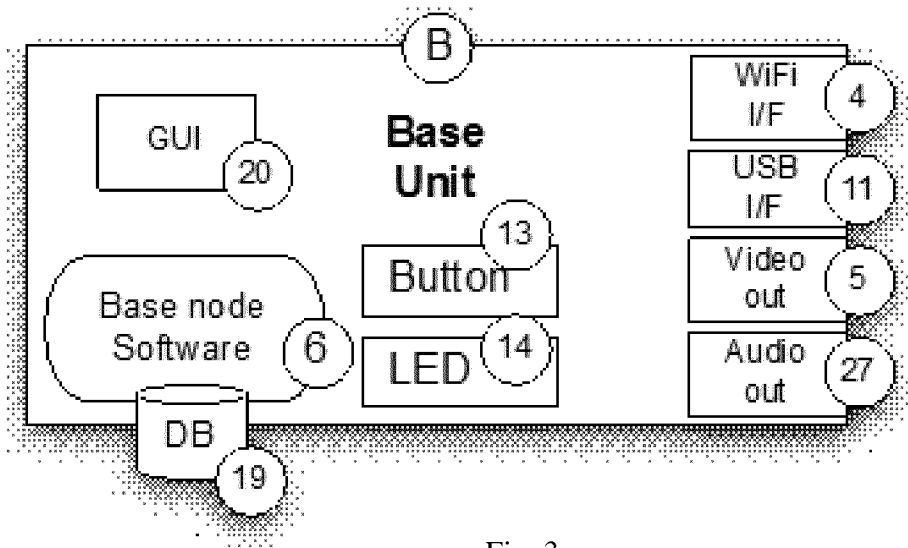

Fig. 3

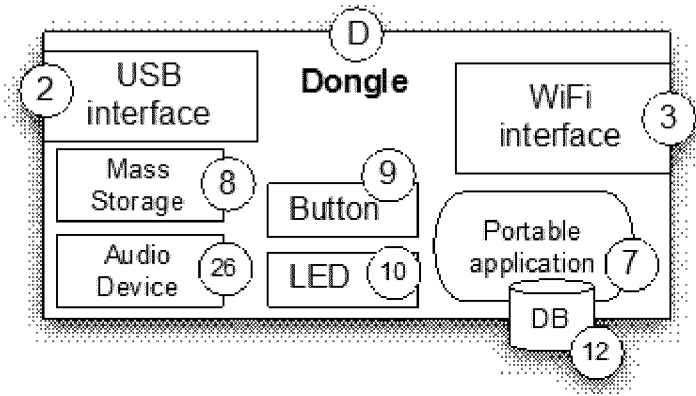

Fig. 4

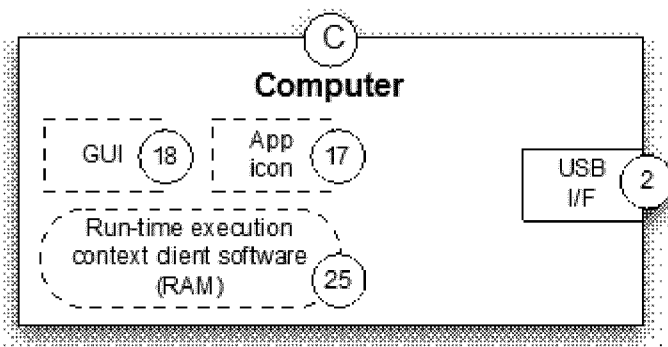

Fig. 5

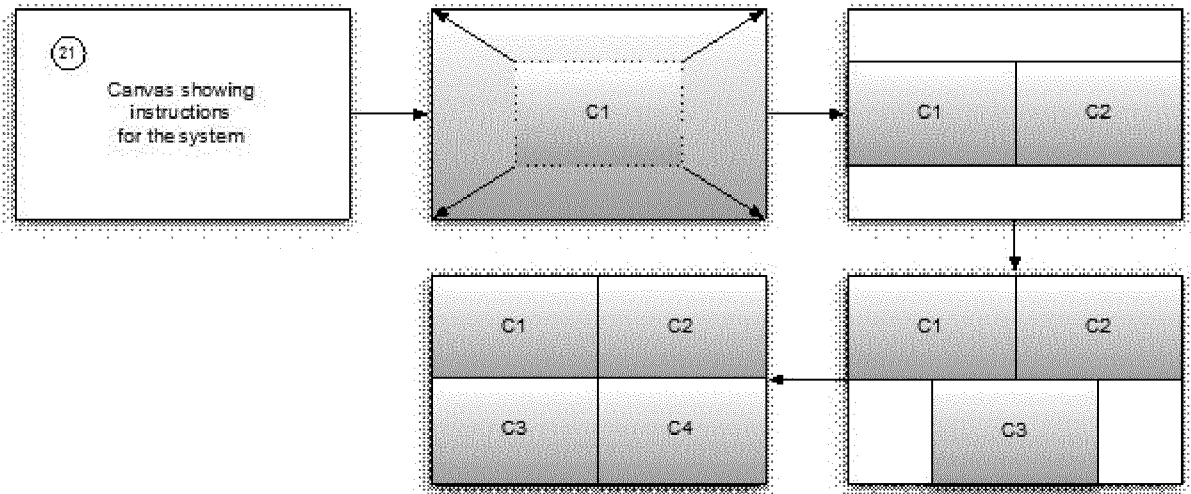

Fig. 6

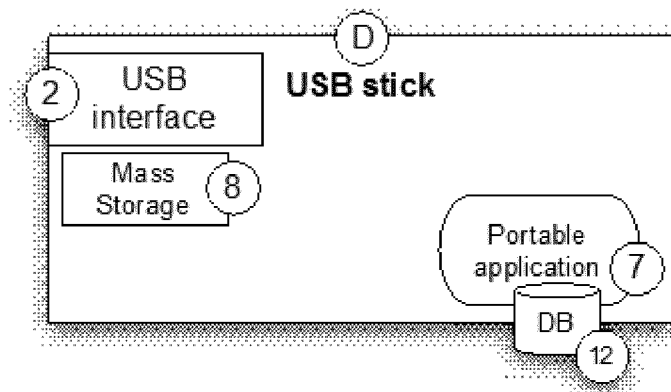

Fig.7

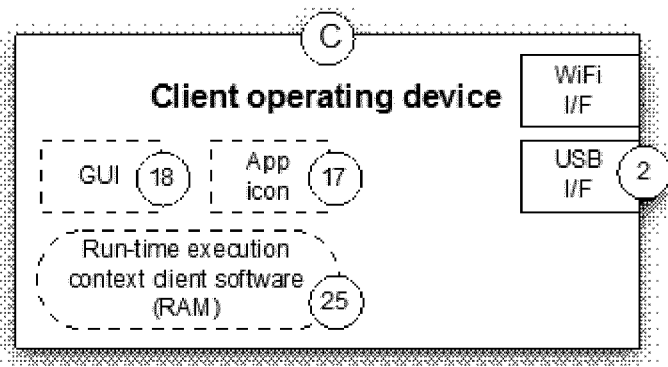

Fig. 8

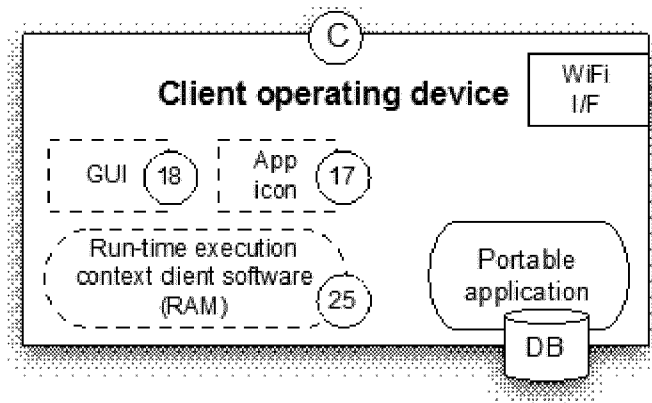

Fig. 9

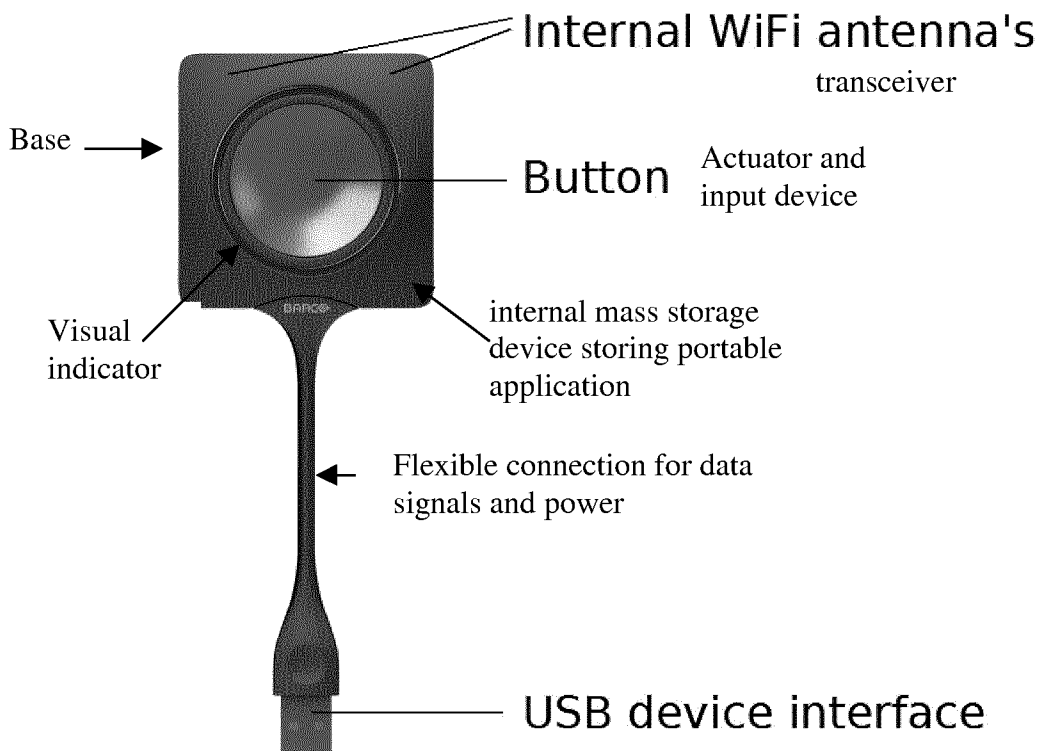

Fig. 10

INTERNATIONAL SEARCH REPORT

International application No
PCT/EP2012/068166

A. CLASSIFICATION OF SUBJECT MATTER
 INV. H04N7/15 H04N21/41 G06F9/54 H04M3/56
 ADD.
 According to International Patent Classification (IPC) or to both national classification and IPC

B. FIELDS SEARCHED
 Minimum documentation searched (classification system followed by classification symbols)
 H04N G06F H04M

Documentation searched other than minimum documentation to the extent that such documents are included in the fields searched

Electronic data base consulted during the international search (name of data base and, where practicable, search terms used)
 EPO-Internal

C. DOCUMENTS CONSIDERED TO BE RELEVANT

Category*	Citation of document, with indication, where appropriate, of the relevant passages	Relevant to claim No.
X	US 2005/036509 A1 (ACHARYA SHRIKANT [US] ET AL) 17 February 2005 (2005-02-17) paragraph [0036] - paragraph [0044] figures 1,2	1-61
A	----- EP 1 187 480 A1 (TELESUITE CORP [US]) 13 March 2002 (2002-03-13) paragraph [0070] - paragraph [0089] figures 1, 5a - 6d	1-61
A	----- US 2004/263636 A1 (CUTLER ROSS [US] ET AL) 30 December 2004 (2004-12-30) paragraph [0046] - paragraph [0048] paragraph [0106] - paragraph [0108] paragraph [0142] - paragraph [0153] paragraph [0168] - paragraph [0193] figures 1-4,7-10	1-61

Further documents are listed in the continuation of Box C. See patent family annex.

* Special categories of cited documents :

"A" document defining the general state of the art which is not considered to be of particular relevance	"T" later document published after the international filing date or priority date and not in conflict with the application but cited to understand the principle or theory underlying the invention
"E" earlier application or patent but published on or after the international filing date	"X" document of particular relevance; the claimed invention cannot be considered novel or cannot be considered to involve an inventive step when the document is taken alone
"L" document which may throw doubts on priority claim(s) or which is cited to establish the publication date of another citation or other special reason (as specified)	"Y" document of particular relevance; the claimed invention cannot be considered to involve an inventive step when the document is combined with one or more other such documents, such combination being obvious to a person skilled in the art
"O" document referring to an oral disclosure, use, exhibition or other means	"&" document member of the same patent family
"P" document published prior to the international filing date but later than the priority date claimed	

Date of the actual completion of the international search 26 February 2013	Date of mailing of the international search report 06/03/2013
---	--

Name and mailing address of the ISA/ European Patent Office, P.B. 5818 Patentlaan 2 NL - 2280 HV Rijswijk Tel. (+31-70) 340-2040, Fax: (+31-70) 340-3016	Authorized officer Van der Zaal, Robert
--	--

INTERNATIONAL SEARCH REPORT

Information on patent family members

International application No PCT/EP2012/068166

Patent document cited in search report	Publication date	Publication date	Patent family member(s)	Publication date
US 2005036509	A1	17-02-2005	NONE	
<hr style="border-top: 1px dashed black;"/>				
EP 1187480	A1	13-03-2002	AT 220838 T	15-08-2002
			AT 311724 T	15-12-2005
			AU 697578 B2	08-10-1998
			AU 3634495 A	09-04-1996
			CA 2200477 A1	28-03-1996
			DE 69527440 D1	22-08-2002
			DE 69527440 T2	20-02-2003
			DE 69534660 D1	05-01-2006
			DE 69534660 T2	27-07-2006
			EP 0806115 A1	12-11-1997
			EP 1187480 A1	13-03-2002
			JP H10508990 A	02-09-1998
			US 5572248 A	05-11-1996
			US 5751337 A	12-05-1998
			US 6160573 A	12-12-2000
			US 6445405 B1	03-09-2002
			US 2003020805 A1	30-01-2003
			US 2004100553 A1	27-05-2004
			US 2007120954 A1	31-05-2007
			WO 9609722 A1	28-03-1996
<hr style="border-top: 1px dashed black;"/>				
US 2004263636	A1	30-12-2004	US 2004263636 A1	30-12-2004
			US 2009046139 A1	19-02-2009
<hr style="border-top: 1px dashed black;"/>				