



- (51) International Patent Classification:
F16F 15/02 (2006.01) F16F 13/00 (2006.01)
F16F 15/023 (2006.01) B60K 5/12 (2006.01)
- (21) International Application Number:
PCT/US2014/036750
- (22) International Filing Date:
5 May 2014 (05.05.2014)
- (25) Filing Language: English
- (26) Publication Language: English
- (30) Priority Data:
61/819,263 3 May 2013 (03.05.2013) US
- (71) Applicant: TRELLEBORG AUTOMOTIVE USA, INC.
[US/US]; 400 Alyworth Avenue, South Haven, MI 49090 (US).
- (72) Inventor: PREIKSZAS, Otto, John; 3254 Crystal Valley Court, Holland, MI 49424 (US).
- (74) Agents: MORGAN KLUG, Erin et al.; Gifford, Krass, Sprinkle, Anderson & Citkowski P.C., 2701 Troy Center Drive, Suite 330, Post Office Box 7021, Troy, MI 48007-7021 (US).

- (81) Designated States (unless otherwise indicated, for every kind of national protection available): AE, AG, AL, AM, AO, AT, AU, AZ, BA, BB, BG, BH, BN, BR, BW, BY, BZ, CA, CH, CL, CN, CO, CR, CU, CZ, DE, DK, DM, DO, DZ, EC, EE, EG, ES, FI, GB, GD, GE, GH, GM, GT, HN, HR, HU, ID, IL, IN, IR, IS, JP, KE, KG, KN, KP, KR, KZ, LA, LC, LK, LR, LS, LT, LU, LY, MA, MD, ME, MG, MK, MN, MW, MX, MY, MZ, NA, NG, NI, NO, NZ, OM, PA, PE, PG, PH, PL, PT, QA, RO, RS, RU, RW, SA, SC, SD, SE, SG, SK, SL, SM, ST, SV, SY, TH, TJ, TM, TN, TR, TT, TZ, UA, UG, US, UZ, VC, VN, ZA, ZM, ZW.
- (84) Designated States (unless otherwise indicated, for every kind of regional protection available): ARIPO (BW, GH, GM, KE, LR, LS, MW, MZ, NA, RW, SD, SL, SZ, TZ, UG, ZM, ZW), Eurasian (AM, AZ, BY, KG, KZ, RU, TJ, TM), European (AL, AT, BE, BG, CH, CY, CZ, DE, DK, EE, ES, FI, FR, GB, GR, HR, HU, IE, IS, IT, LT, LU, LV, MC, MK, MT, NL, NO, PL, PT, RO, RS, SE, SI, SK, SM, TR), OAPI (BF, BJ, CF, CG, CI, CM, GA, GN, GQ, GW, KM, ML, MR, NE, SN, TD, TG).

Published:
— with international search report (Art. 21(3))

[Continued on next page]

(54) Title: HYDRAULIC ENGINE MOUNT INERTIA TRACK WITH AT LEAST TWO RESTRICTIONS

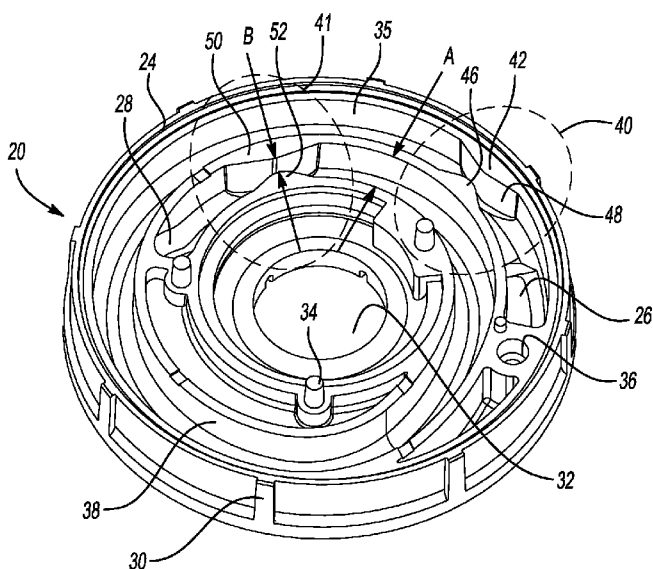

Fig-2

(57) Abstract: A hydraulic engine mount is provided having at least one channel provided within the engine mount. The channel is provided fully enclosed within the engine mount. The channel includes at least two restrictions operable to partially restrict fluid flow through the channel thereby preventing unwanted noise heard by the user. The at least two restrictions include at least one protrusion extending away from a side wall of the channel. Two protrusions are provided to form each restriction where the protrusions are opposed and spaced apart extending into the channel. The at least one protrusion includes at least one sloped wall. The at least one sloped wall is disposed upstream of the fluid through the channel and may be positioned adjacent to an inlet or an outlet of the channel.



- *before the expiration of the time limit for amending the claims and to be republished in the event of receipt of amendments (Rule 48.2(h))*

HYDRAULIC ENGINE MOUNT INERTIA TRACK WITH AT LEAST TWO RESTRICTIONS

CROSS-REFERENCE TO RELATED APPLICATIONS

5 [0001] This application claims priority of U.S. Provisional Patent Application Serial No. 61/819,263 filed May 3, 2013, incorporated herein by reference.

FIELD OF THE INVENTION

[0002] The present invention relates generally to engine mounts. More particularly, the present invention relates to a hydraulic engine mount having an inertia track.

BACKGROUND OF THE INVENTION

10 [0003] It is common for hydraulic engine mounts to have an inertia track assembly having an upper inertia track and a lower inertia track. The hydraulic engine mount assembly having an inertia track assembly often includes an elastomeric disc (decoupler) captured between the upper and lower inertia tracks (See Figure 7 illustrating the prior art). The inertia track is a channel filled with a hydraulic fluid moving between the upper and lower chambers of the hydraulic
15 mount. The inertia track is unobstructed throughout the entire length of the track to offer the most efficient movement of fluid within the track as it enters and exits the track.

[0004] However, a common problem with a fluid filled engine mount inertia track is that the decoupler disc creates noise caused by the contact between the disc and the inertia track pieces. The contact of the disc also produces a force which is transferred through the mount to the
20 attaching vehicle structure which can cause vibration and/or noise in the vehicle and heard by the user. Accordingly, there exists a need in the art to provide a hydraulic engine mount having a fluid filled inertia track with decreased vibration and noise.

SUMMARY OF THE INVENTION

25 [0005] A hydraulic engine mount is provided having at least one channel provided within the engine mount. The channel is provided fully enclosed within the engine mount. The channel includes at least two restrictions—operable to partially restrict fluid flow through the channel thereby reducing pressure and mitigating unwanted noise heard by the user. The at least two restrictions each include at least one protrusion extending away from a side wall of the channel.

Two protrusions are provided forming the restriction where the protrusions are opposed and spaced apart extending into the channel. The at least one protrusion includes at least one sloped wall. The at least one sloped wall is disposed upstream of the fluid through the channel and may be positioned adjacent to an inlet or an outlet of the channel. (Not sure what is trying to be said here)

5 [0006] A hydraulic engine mount is provided having a base portion and a channel extending through the base portion of the engine mount. The channel is adapted to allow fluid to flow through the engine mount. At least two restrictions disposed within the channel thereby restricting fluid flow through the channel. The at least two restrictions includes at least one 10 protrusion extending away from a side wall of the channel. In one embodiment, the hydraulic engine mount of claim 1 wherein the at least one protrusion include two total protrusions being opposed and spaced apart extending into the channel. The at least one protrusion includes at least one sloped wall. The at least one sloped wall is disposed upstream of the fluid through the channel.

15 [0007] A hydraulic engine mount including a channel where the channel has a first side wall and a second side wall, the second side wall being opposed and spaced apart from the first side wall. The restrictions are disposed within the channel, the restrictions having a first protrusion on the first side wall of the channel, a second protrusion provided opposed and spaced apart from the first protrusion thereby restricting fluid flow through the channel. The first protrusion and the 20 second protrusion each have a sloped surface. In one embodiment, the restriction is disposed adjacent to an inlet within the channel. In yet another embodiment, the restriction is disposed adjacent to an outlet within the channel.

BRIEF DESCRIPTION OF THE DRAWINGS

25 [0008] Figure 1 illustrates a perspective view of an installed engine mount of the present invention;

[0009] Figure 2 illustrates a perspective view of the inertia track having restriction points of the present invention;

[0010] Figure 3 illustrates a perspective bottom view of the inertia track of the present invention;

30 [0011] Figure 4 illustrates a top view of the inertia track of the present invention;

[0012] Figure 5 illustrates a cross-sectional view of the inertia track along the line 5-5 of Figure 4;

[0013] Figure 6 illustrates a cross sectional view of the inertia track along the 6-6 of Figure 4; and

5 [0014] Figure 7 illustrates an inertia track of the prior art without any restrictions.

DETAILED DESCRIPTION OF THE INVENTION

[0015] The present invention provides for a hydraulic engine mount for dampening having an inertia track having multiple restrictions or pinch points. The inner surface of the inertia track is modified to create multiple points of restriction to alter the hydraulic fluid flow through the inertia track. The inclusion of two or more restriction points within the inertia track substantially decreases the pressure of the fluid and noise as heard by the user of the vehicle. The restriction points added to the inside of the inertia track influence the flow of fluid through the track such that energy is absorbed into the restriction points to reduce the transmitted force through the mount. The restriction points within the inertia track are generally triangle shaped or curved features protruding inward to the center of the inertia track from either side or surface of the inertia track thereby locally restricting the effective cross section for the fluid to pass through. The restriction points are positioned near the inlet and outlet features of the inertia track.

10 [0016] Figure 1 illustrates the partial mount 20 having an inertia track (or channel). The mount and inertia track include an inlet allowing fluid to enter the inertia track 12 and an outlet 18 to transport fluid from a first chamber to a second chamber. The mount 10 further includes an outer surface 16 which may be housed in a separate housing. The inertia track 12 of the prior art includes a smooth inner surface without having any obstructions or restrictions. The cross-sectional dimensions of the inertia track 12 remain relatively consistent from the inlet 14 to the outlet 18.

25 [0017] Figures 2-4 illustrate the partial mount 20 having an inertia track (or channel) 22 of the present invention. The mount 20 includes an upper surface 24 which may also be a seal. The inertia track 20 includes an inlet 26 and an outlet 28. The inlet 26 is operable to receive fluid from a first chamber. The fluid then flows through the inertia track 22 and out through the outlet 28 to a second chamber.

[0018] The mount 20 includes an outer surface 30 and an inner rubber portion (not pictured). Various attachment features and apertures 34, 36 are provided to connect and align the various components of the full engine mount to one another.

5 [0019] The inertia track 22 includes a first surface 35 and a second surface 38. The first surface 35 is the outermost surface of the inertia track 22. The second surface 38 is the innermost surface of the inertia track 22.

[0020] In the present embodiment, the inertia track 22 assembly as shown in Figure 2 is made of plastic, aluminum or other suitable material. In alternative embodiments, the assembly is made of a plastic, polymer, plastic like, rubber, or polymer like material suitable for use in the
10 engine mount.

[0021] The inertia track 22 includes the first surface 35 and the second surface 38. Various protrusions are included on both the first surface 35 and on the second surface 38 to create two restriction points 40, 41. The first restriction point 40 is positioned near the inlet 26 of the inertia track 22. The positioning of the restriction point 40 near the inlet 26 greatly reduces the overall
15 pressure and thus noise of the engine mount.

[0022] A second restriction point 41 is positioned at a point later down the inertia track 22 near the outlet 28 of the inertia track 20. The second restriction point 42 also reduces the overall fluid pressure and thus noise of the engine mount. The inclusion of the two restriction points 40, 41 dramatically reduces the overall noise of the engine mount. Testing has shown a significant
20 drop in noise with the inclusion of at least two restriction points.

[0023] The first restriction point 40 includes a first protrusion 42 and a second protrusion 46. The first protrusion 42 as compared to the second protrusion 46 may vary in dimension and size. In the present embodiment, the first protrusion 42 has a generally triangular shape having generally planar surfaces 48. Conversely, the second protrusion 46 includes a generally curved
25 surface protruding to the center of the inertia track 22. These configurations may be reversed or duplicated according to the requirements of the vehicle.

[0024] The second restriction point 41 includes a first protrusion 50 and a second protrusion 52. In accordance with the arrangement of the first restriction point 40, the first protrusion 50 includes a generally triangular shaped protrusion extending into the center of the inertia track 22.
30 The second protrusion 52 is curved and with a rounded point extends into the inertia track 22. The first protrusion 50 includes generally planar surfaces 54 to create a generally triangular shape.

[0025] The restriction points 40, 41 change the geometry of the inertia track 22. Specifically, the restriction points 40, 41 decrease the distance between the first surface 35 and the second surface 38. Throughout most of the length of the inertia track 22 the inertia track 22 includes a spaced apart distance A between the first surface 35 and the second surface 38. The distance A throughout the inertia track 22 is generally constant with the exception of a few points near the inlet 26 and the outlet 28 of the inertia track. At the restriction points 40, 41, the distance between the first surface 35 and the second surface 38 of the inertia track 22 is at a predetermined distance B. The distance B is the smallest point, thus being a restriction point, of the inertia track 22.

[0026] The protrusions 42, 46, 50, 52 gradually decrease the distance between the first surface 35 and the second surface 38 until the distance between the first surface 35 and the second surface 38 is at a minimum at the distance B. This restriction point locally restricts the effective cross section for the fluid to pass through the inertia track 22. These restriction points 40, 41 significantly reduce noise by influencing the flow of fluid through the inertia track 22 such that energy is absorbed into the restriction points 40, 41 thereby reducing the transmitted forces throughout the engine mount. As such, at least two restriction points are required to reduce the noise level of the engine mount.

[0027] The invention is not restricted to the illustrative examples and embodiments described above. The embodiments are not intended as limitations on the scope of the invention. Methods, apparatus, compositions, and the like described herein are exemplary and not intended as limitations on the scope of the invention. Changes therein and other uses will occur to those skilled in the art.

CLAIMS

1. A hydraulic engine mount having hydraulic fluid comprising:
at least one channel provided within the engine mount, the channel fully enclosed within
the engine mount;
- 5 the channel having at least two restriction operable to partially restrict fluid flow through
the channel thereby preventing unwanted noise heard by the user.
2. The hydraulic engine mount of claim 1 wherein the at least two restrictions each
include at least one protrusion extending away from a side wall of the channel.
- 10 3. The hydraulic engine mount of claim 2 wherein the at least two restrictions each
have two total protrusions being opposed and spaced apart extending into the channel.
4. The hydraulic engine mount of claim 2 wherein the at least one protrusion
15 includes at least one sloped wall.
5. The hydraulic engine mount of claim 4 wherein the at least one sloped wall is
disposed upstream of the fluid through the channel.
- 20 6. A hydraulic engine mount having hydraulic fluid comprising:
a base portion;
a channel extending through the base portion of the engine mount, the channel adapted to
allow fluid to flow through the engine mount;
at least two restrictions disposed within the channel, the at least two restrictions
25 extending into the at least one channel thereby restricting fluid flow through the channel.
7. The hydraulic engine mount of claim 1 wherein the at least two restrictions each
include at least one protrusion extending away from a side wall of the channel.
- 30 8. The hydraulic engine mount of claim 7 wherein the at least one protrusion include
two total protrusions for each restriction being opposed and spaced apart extending into the
channel.

9. The hydraulic engine mount of claim 7 wherein the at least one protrusion includes at least one sloped wall.

5 10. The hydraulic engine mount of claim 9 wherein the at least one sloped wall is disposed upstream of the fluid through the channel.

10 11. A hydraulic engine mount having hydraulic fluid comprising:
a channel, the channel having a first side wall and a second side wall, the second side wall being opposed and spaced apart from the first side wall;
a pair of restrictions disposed within the channel, the restrictions each having a first protrusion on the first side wall of the channel, the restrictions each having a second protrusion provided opposed and spaced apart from the first protrusion thereby restricting fluid flow through the channel to reduce pressure and noise within the channel.

15 12. The hydraulic engine mount of claim 11 wherein the first protrusion and the second protrusion each have a sloped surface.

20 13. The hydraulic engine mount of claim 11 wherein one restriction is disposed adjacent to an inlet within the channel.

25 14. The hydraulic engine mount of claim 11 wherein one restriction is disposed adjacent to an outlet within the channel.

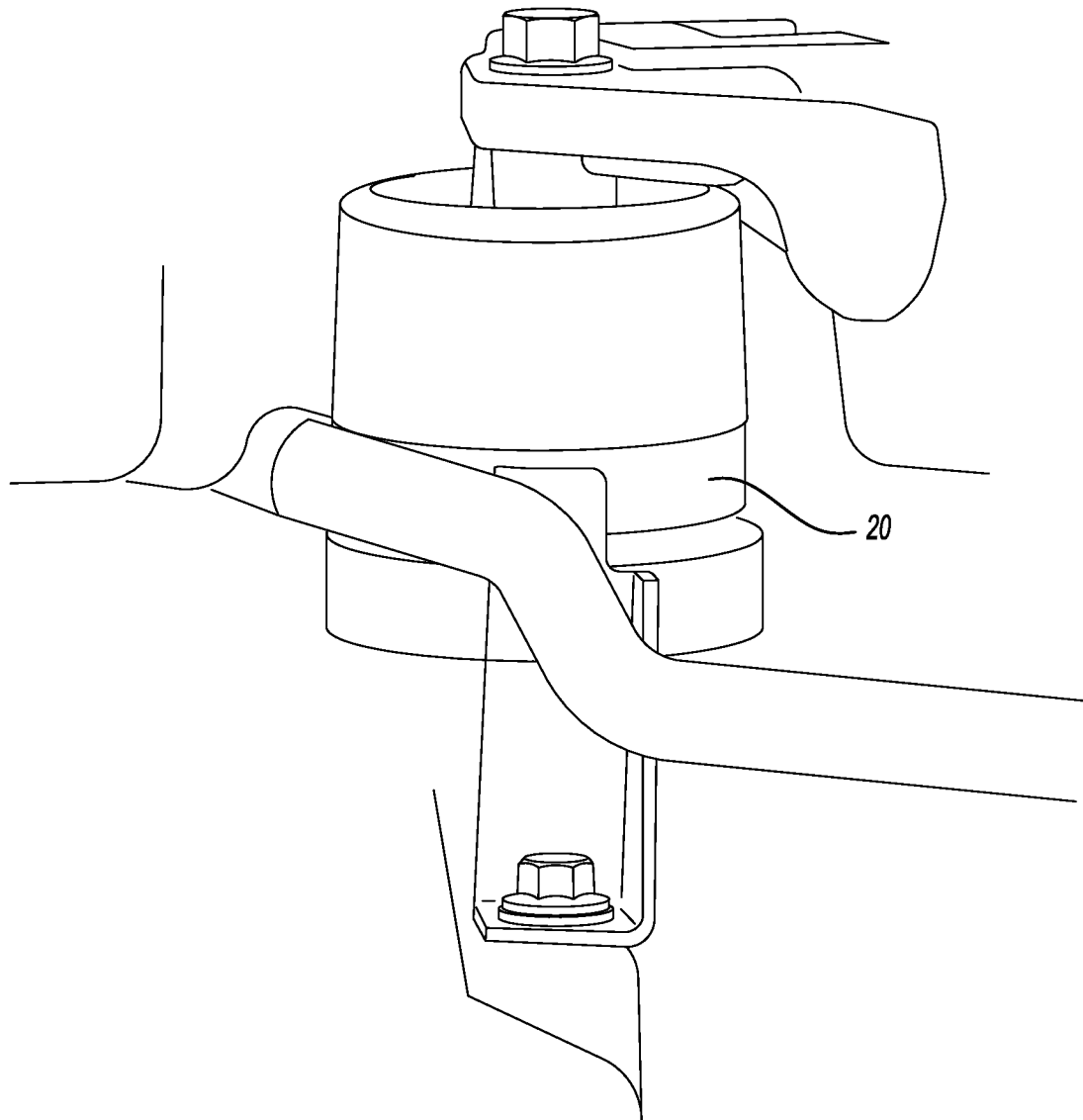

Fig-1

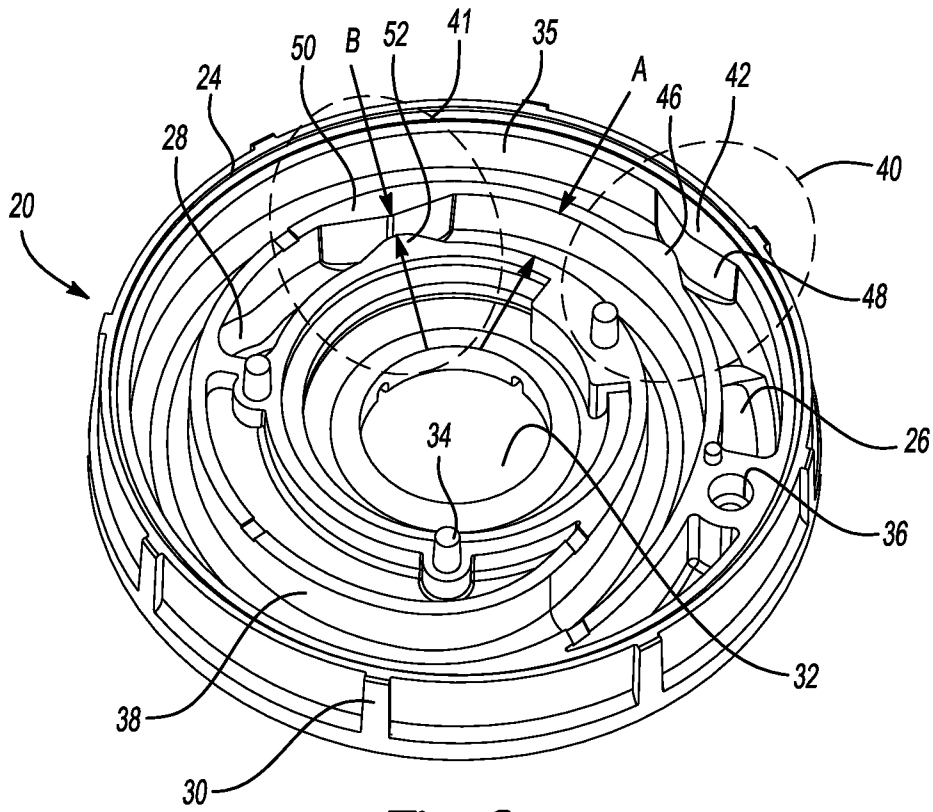

Fig-2

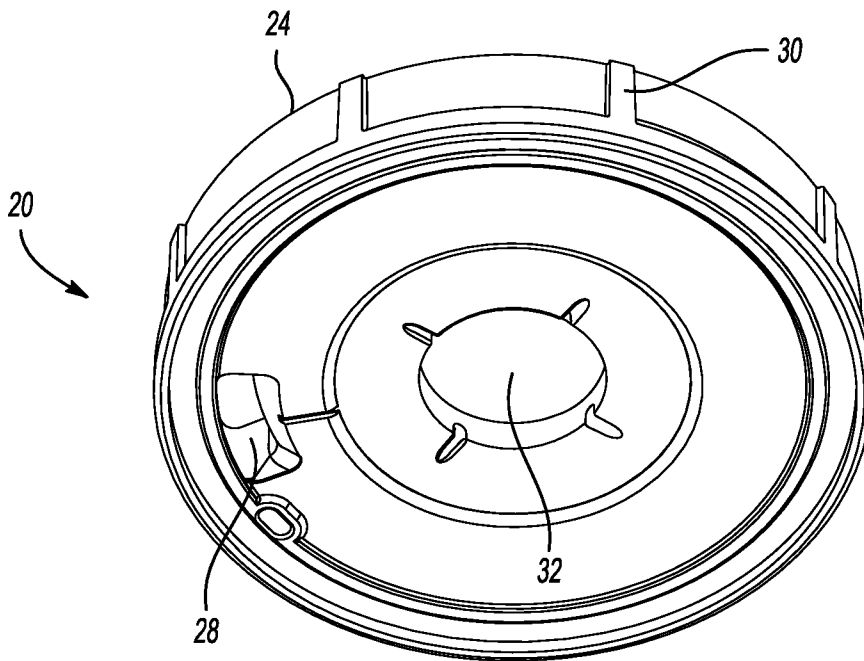

Fig-3

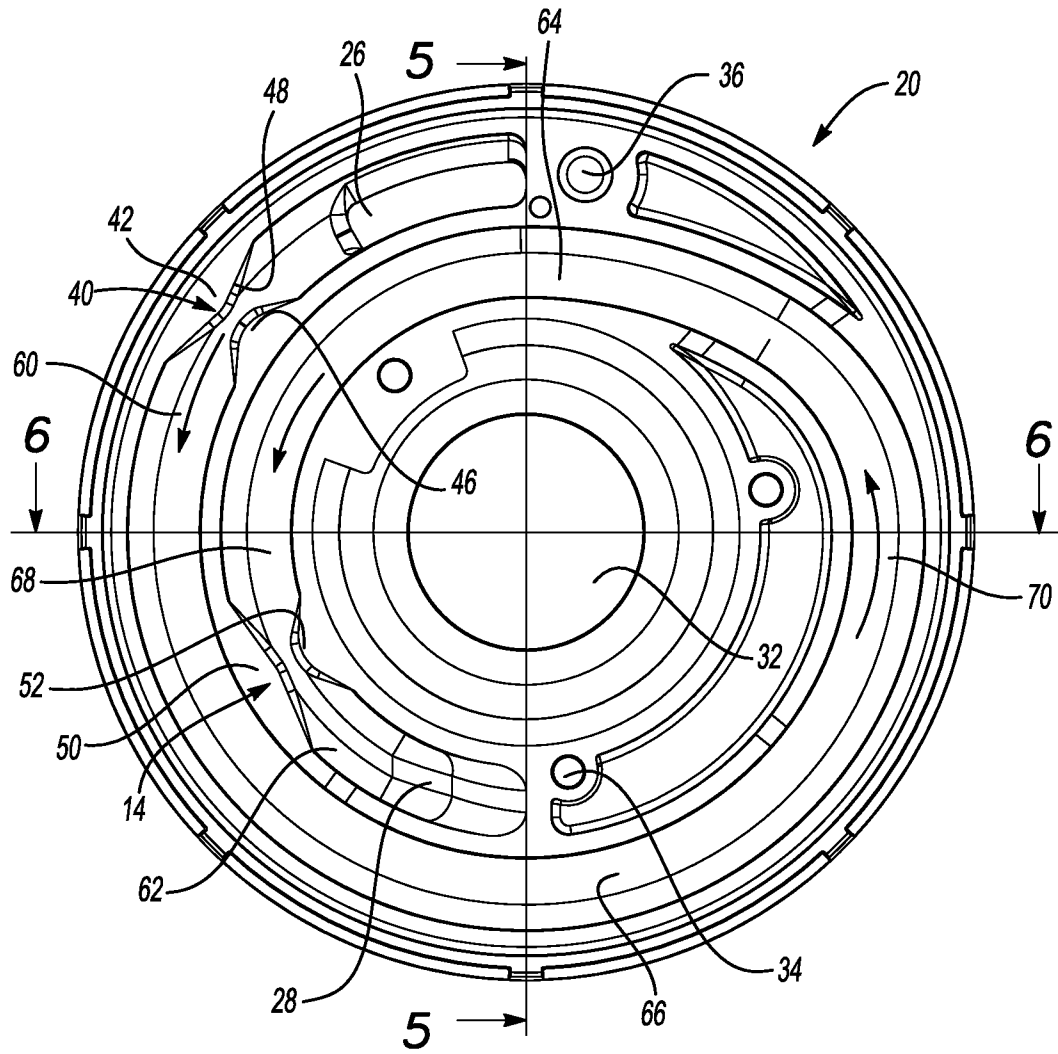
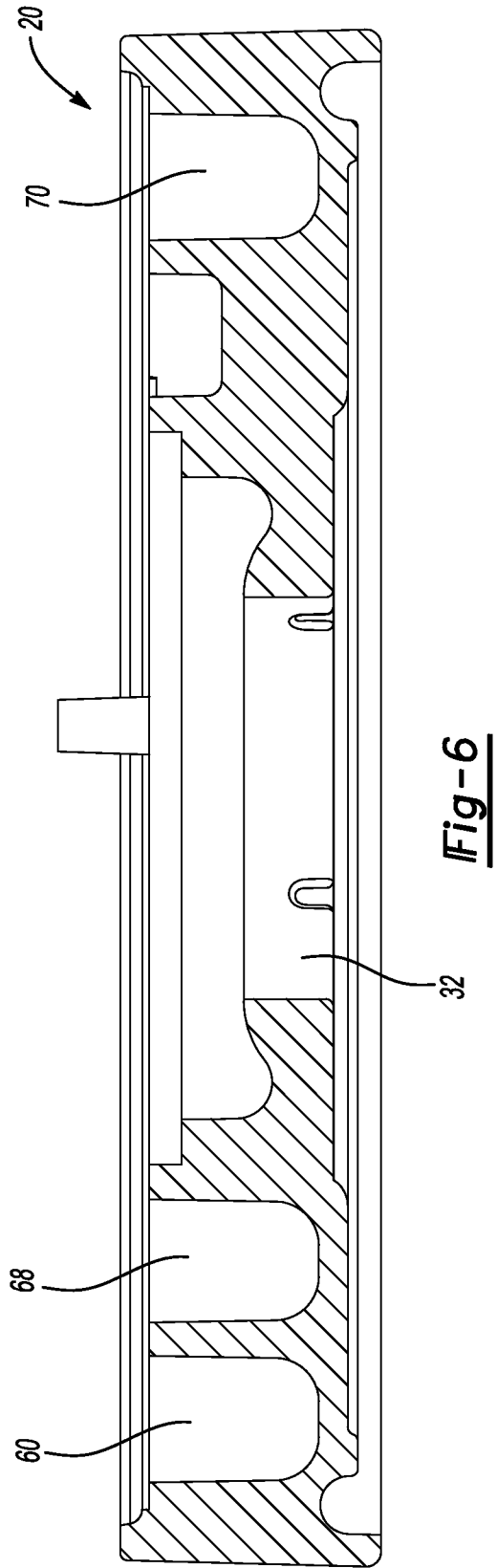
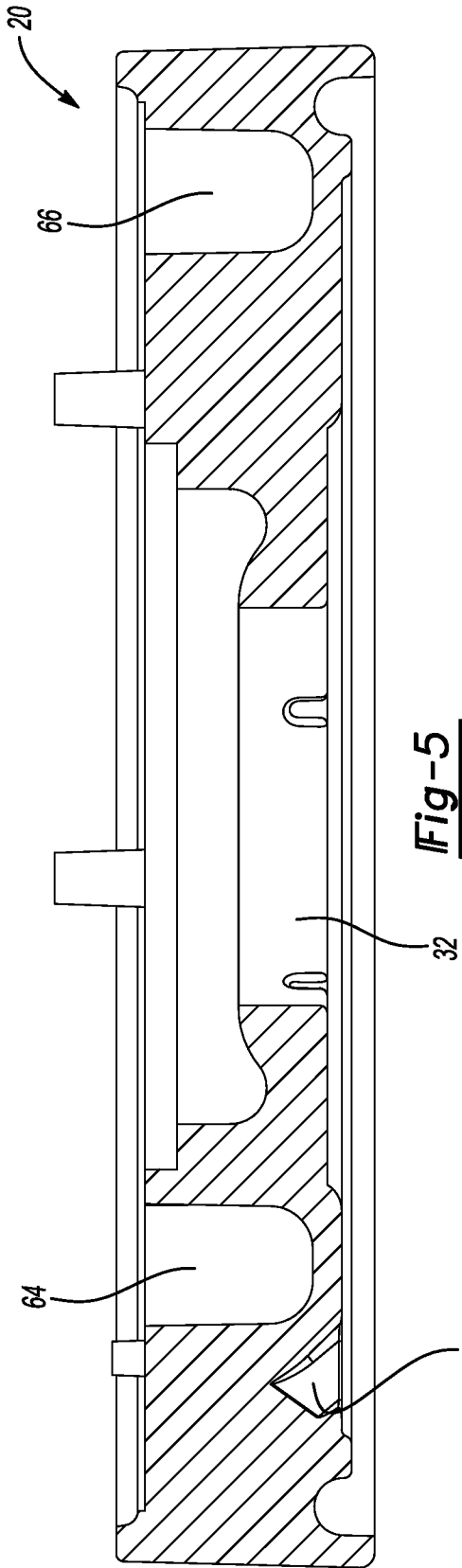

Fig-4



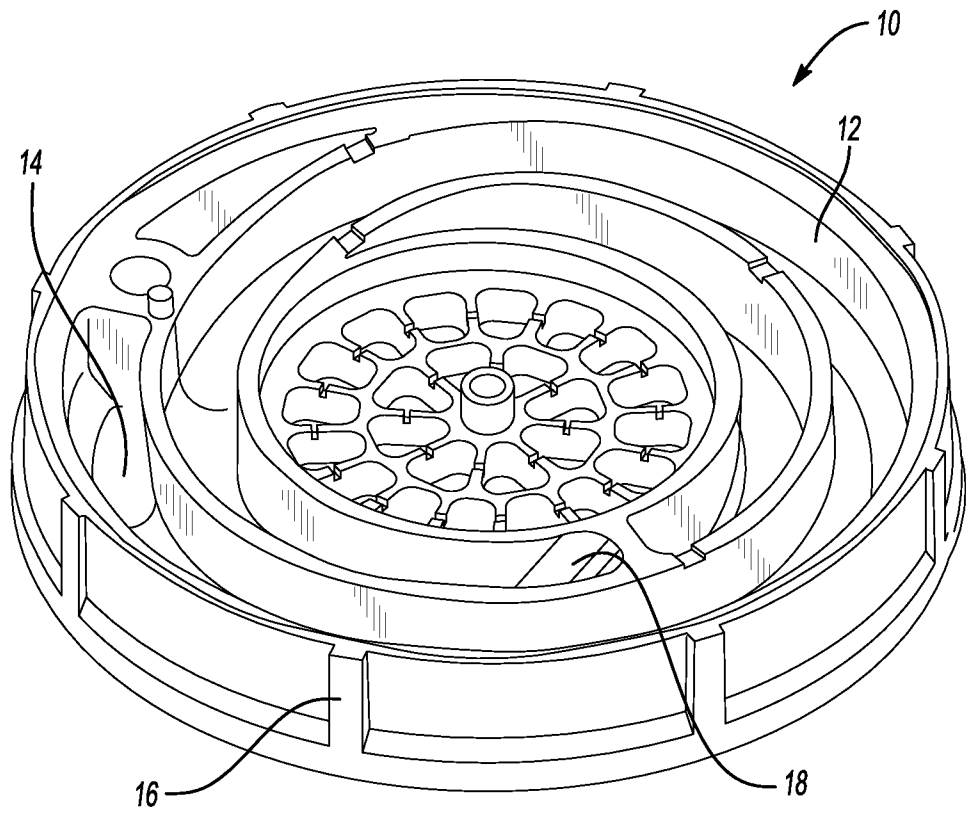

Fig-7
PRIOR ART

A. CLASSIFICATION OF SUBJECT MATTER**F16F 15/02(2006.01)i, F16F 15/023(2006.01)i, F16F 13/00(2006.01)i, B60K 5/12(2006.01)i**

According to International Patent Classification (IPC) or to both national classification and IPC

B. FIELDS SEARCHED

Minimum documentation searched (classification system followed by classification symbols)

F16F 15/02; F16F 15/04; F16F 5/00; B60G 15/04; F16F 13/26; F16F 13/10; F16M 5/00; F16F 15/023; F16F 13/00; B60K 5/12

Documentation searched other than minimum documentation to the extent that such documents are included in the fields searched

Korean utility models and applications for utility models

Japanese utility models and applications for utility models

Electronic data base consulted during the international search (name of data base and, where practicable, search terms used)

eKOMPASS(KIPO internal) & Keywords: hydraulic, damper, channel, protrusion, and throttle

C. DOCUMENTS CONSIDERED TO BE RELEVANT

Category*	Citation of document, with indication, where appropriate, of the relevant passages	Relevant to claim No.
X	EP 0995927 A2 (DRAFTEX INDUSTRIES LIMITED) 26 April 2000 See paragraphs [0009], [0010], [0015], [0016]; and figures 1,2.	1,6
Y		2-5, 7-14
Y	US 5,118,087 A (JORDENS et al.) 02 June 1992 See column 3, lines 30-34; and figure 6.	2-5, 7-14
A	US 4,921,232 A (HOFMANN, MANFRED) 01 May 1990 See column 2, lines 42-63; and figures 1,2.	1-14
A	US 6,308,942 B1 (ERSOY et al.) 30 October 2001 See column 3, lines 32-38, column 4, lines 35-39; and figures 1,3.	1-14
A	US 4,836,515 A (FRANZ et al.) 06 June 1989 See column 3, lines 34-40; and figures 1,2.	1-14

 Further documents are listed in the continuation of Box C. See patent family annex.

* Special categories of cited documents:

"A" document defining the general state of the art which is not considered to be of particular relevance

"E" earlier application or patent but published on or after the international filing date

"L" document which may throw doubts on priority claim(s) or which is cited to establish the publication date of another citation or other special reason (as specified)

"O" document referring to an oral disclosure, use, exhibition or other means

"P" document published prior to the international filing date but later than the priority date claimed

"T" later document published after the international filing date or priority date and not in conflict with the application but cited to understand the principle or theory underlying the invention

"X" document of particular relevance; the claimed invention cannot be considered novel or cannot be considered to involve an inventive step when the document is taken alone

"Y" document of particular relevance; the claimed invention cannot be considered to involve an inventive step when the document is combined with one or more other such documents, such combination being obvious to a person skilled in the art

"&" document member of the same patent family

Date of the actual completion of the international search

02 September 2014 (02.09.2014)

Date of mailing of the international search report

03 September 2014 (03.09.2014)

Name and mailing address of the ISA/KR

International Application Division
Korean Intellectual Property Office
189 Cheongsu-ro, Seo-gu, Daejeon Metropolitan City, 302-701,
Republic of Korea

Facsimile No. +82-42-472-7140

Authorized officer

HAN, Joong Sub

Telephone No. +82-42-481-5606

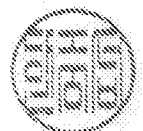

INTERNATIONAL SEARCH REPORT

Information on patent family members

International application No.

PCT/US2014/036750

Patent document cited in search report	Publication date	Patent family member(s)	Publication date
EP 0995927 A2	26/04/2000	EP 0995927 A3 GB 2342977 A GB 9823109 D0	04/04/2001 26/04/2000 16/12/1998
US 5118087 A	02/06/1992	EP 0418671 A1 EP 0418671 B1 JP 03-107637 A JP 06081977 B	27/03/1991 13/04/1994 08/05/1991 19/10/1994
US 4921232 A	01/05/1990	EP 0306752 A2 EP 0306752 A3 JP 01-098721 A	15/03/1989 15/11/1989 17/04/1989
US 6308942 B1	30/10/2001	BR 0006021 A DE 19915480 A1 DE 19915480 C2 EP 1084354 A1 EP 1084354 B1 ES 2220469 T3 JP 03530492 B2 JP 2002-541396 A WO 00-60251 A1	06/03/2001 02/11/2000 04/10/2001 21/03/2001 16/06/2004 16/12/2004 24/05/2004 03/12/2002 12/10/2000
US 4836515 A	06/06/1989	EP 0248942 A3 JP 02055656 B JP 62-297553 A	08/06/1988 28/11/1990 24/12/1987