



(51) International Patent Classification:
A61M 25/06 (2006.01)

(21) International Application Number:
PCT/US2019/018185

(22) International Filing Date:
15 February 2019 (15.02.2019)

(25) Filing Language: English

(26) Publication Language: English

(30) Priority Data:
62/631,082 15 February 2018 (15.02.2018) US

(71) Applicant: **BOSTON SCIENTIFIC SCIMED, INC.**
[US/US]; One Scimed Place, Maple Grove, Minnesota 55311 (US).

(72) Inventors: **HART, Matthew**; 9139 Orchid Lane, Maple Grove, Minnesota 55369 (US). **MEYER, Corey N.**; 10501 281st Ave NW, Zimmerman, Minnesota 55398 (US). **LARSON, Derek Kenneth**; 8601 Duluth St, Golden Valley, Minnesota 55427 (US). **BREIDALL, Benjamin**; 10821 Grant Drive, Eden Prairie, Minnesota 55347 (US). **MARTIN, Kevin**; 17565 72nd place n, Maple Grove, Minnesota 55311 (US). **VELEZ, Victoria**; 2935 Fremont Ave

S, Apt 416, Minneapolis, Minnesota 55408 (US). **ADAMS, Nathan**; 3029 Fremont Ave S, Minneapolis, Minnesota 55408 (US).

(74) Agent: **SEAGER, Glenn M.**; Seager, Tufte & Wickhem, LLP, 100 South 5th Street, Suite 600, Minneapolis, Minnesota 55402 (US).

(81) Designated States (unless otherwise indicated, for every kind of national protection available): AE, AG, AL, AM, AO, AT, AU, AZ, BA, BB, BG, BH, BN, BR, BW, BY, BZ, CA, CH, CL, CN, CO, CR, CU, CZ, DE, DJ, DK, DM, DO, DZ, EC, EE, EG, ES, FI, GB, GD, GE, GH, GM, GT, HN, HR, HU, ID, IL, IN, IR, IS, JO, JP, KE, KG, KH, KN, KP, KR, KW, KZ, LA, LC, LK, LR, LS, LU, LY, MA, MD, ME, MG, MK, MN, MW, MX, MY, MZ, NA, NG, NI, NO, NZ, OM, PA, PE, PG, PH, PL, PT, QA, RO, RS, RU, RW, SA, SC, SD, SE, SG, SK, SL, SM, ST, SV, SY, TH, TJ, TM, TN, TR, TT, TZ, UA, UG, US, UZ, VC, VN, ZA, ZM, ZW.

(84) Designated States (unless otherwise indicated, for every kind of regional protection available): ARIPO (BW, GH, GM, KE, LR, LS, MW, MZ, NA, RW, SD, SL, ST, SZ, TZ, UG, ZM, ZW), Eurasian (AM, AZ, BY, KG, KZ, RU, TJ, TM), European (AL, AT, BE, BG, CH, CY, CZ, DE, DK, EE, ES, FI, FR, GB, GR, HR, HU, IE, IS, IT, LT, LU, LV,

(54) Title: INTRODUCER WITH EXPANDABLE CAPABILITIES

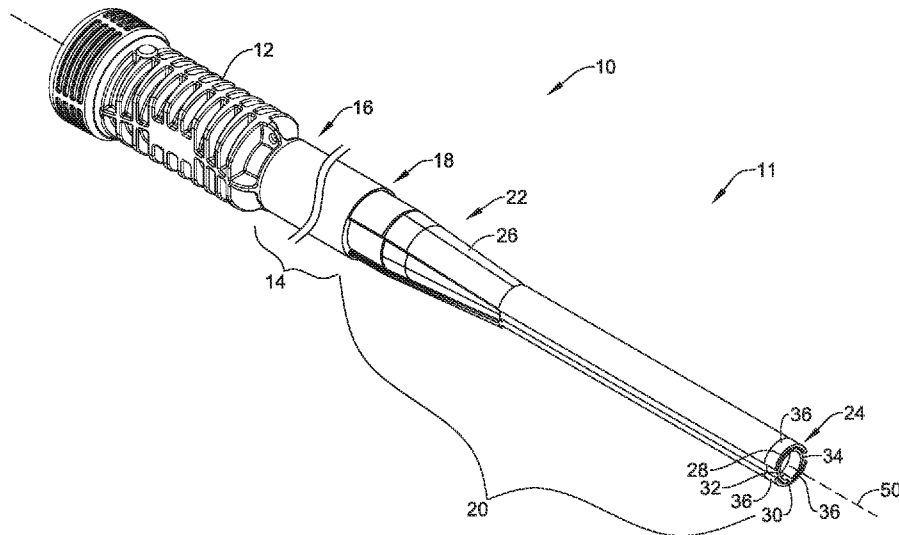

FIG. 1

(57) Abstract: An example introducer and method of use is disclosed. The example introducer sheath includes a shaft including a tubular portion, an expandable portion coupled to the tubular portion and a longitudinal axis. Additionally, the expandable portion includes a first pair of leaflets and a second pair of leaflets and both the first pair of leaflets and the second pair of leaflets extend along the longitudinal axis. Additionally, the second pair of leaflets are spaced radially inward of an inner surface of the first pair of leaflets and the expandable portion is designed to shift between a first configuration and a second expanded configuration.



MC, MK, MT, NL, NO, PL, PT, RO, RS, SE, SI, SK, SM,
TR), OAPI (BF, BJ, CF, CG, CI, CM, GA, GN, GQ, GW,
KM, ML, MR, NE, SN, TD, TG).

Published:

— *with international search report (Art. 21(3))*

INTRODUCER WITH EXPANDABLE CAPABILITIES

CROSS-REFERENCE TO RELATED APPLICATIONS

This application claims the benefit of priority under 35 U.S.C. §119 to U.S.
5 Provisional Application Serial No. 62/631,082, filed February 15, 2018, the entirety of
which is incorporated herein by reference.

TECHNICAL FIELD

The disclosure relates generally to medical devices and more particularly to
10 medical devices that are adapted for use in percutaneous medical procedures.

BACKGROUND

In some instances, performing percutaneous medical procedures may require
the insertion and/or maneuvering of relatively large medical devices through a patient's
15 vasculature. However, inserting the medical device into the vasculature may result in
undesirable forces being applied to the vessel walls. For example, as the medical device
passes into the vasculature, it may make undesirable contact with one or more vessel
walls. This interference may cause injury to the vessel as the medical device is
navigated into calcified or diseased vessels. Therefore, in some instances an introducer
20 is utilize to facilitate the insertion of medical devices into the vessel. Further, vessel
trauma resulting from forces applied to the vessel wall by a medical device may be
lessened by minimizing the size of an introducer used to access the vessel. Therefore,
it may be desirable to design an introducer having a reduced insertion profile, yet
capable of expansion when necessary (e.g., during the passage of a medical device
25 therethrough).

SUMMARY

This disclosure provides design, material, manufacturing method, and use
alternatives for medical devices. An example introducer sheath includes a shaft
30 including a tubular portion, an expandable portion coupled to the tubular portion and a
longitudinal axis. Additionally, the expandable portion includes a first pair of leaflets
and a second pair of leaflets and both the first pair of leaflets and the second pair of
leaflets extend along the longitudinal axis. Additionally, the second pair of leaflets

are spaced radially inward of an inner surface of the first pair of leaflets and the expandable portion is designed to shift between a first configuration and a second expanded configuration.

5 Alternatively or additionally to any of the examples above, wherein the first pair of leaflets includes a first leaflet and a second leaflet, wherein the first leaflet includes a first concave surface extending partially around the longitudinal axis, where the second leaflet includes a second concave surface extending partially around the longitudinal axis and wherein the first concave surface faces the second concave surface.

10 Alternatively or additionally to any of the examples above, wherein the second pair of leaflets includes a third leaflet and a fourth leaflet, wherein the third leaflet includes a third concave surface extending partially around the longitudinal axis, where the fourth leaflet includes a fourth concave surface extending partially around the longitudinal axis and wherein the third concave surface faces the fourth concave surface.

15 Alternatively or additionally to any of the examples above, wherein the first pair of leaflets are circumferentially offset from the second pair of leaflets.

Alternatively or additionally to any of the examples above, wherein the first leaflet is spaced away from the second leaflet to form a first gap extending along the longitudinal axis and a second gap extending along the longitudinal axis.

20 Alternatively or additionally to any of the examples above, wherein the third leaflet is spaced away from the fourth leaflet to form a third gap extending along the longitudinal axis and a fourth gap extending along the longitudinal axis.

Alternatively or additionally to any of the examples above, wherein the first leaflet and the second leaflet are configured to flex radially outward and away from one another when the expandable portion shifts from the first configuration to the second expanded configuration.

25 Alternatively or additionally to any of the examples above, wherein the third leaflet and the fourth leaflet are configured to flex radially outward and away from one another when the expandable portion shifts from the first configuration to the second expanded configuration.

30 Alternatively or additionally to any of the examples above, wherein the first and second leaflets include an inner surface and wherein the third and fourth leaflets

include an outer surface, and wherein the outer surface of the third and fourth leaflets are configured to slide along the inner surfaces of the first and second leaflets when the expandable portion shifts from the first configuration to the second expanded configuration.

5 Alternatively or additionally to any of the examples above, wherein the third leaflet includes an outer surface and a first rib member disposed along the outer surface, and wherein the fourth leaflet includes an outer surface and a second rib member disposed along the outer surface.

 Alternatively or additionally to any of the examples above, wherein the first
10 rib member is positioned within the first gap and wherein the second rib member is positioned within the second gap.

 Alternatively or additionally to any of the examples above, wherein the first leaflet includes a first projection extending radially inward from an inner surface of the first leaflet, and wherein the third leaflet includes a second projection extending
15 radially outward from an outer surface of the third leaflet, and wherein the first projection is configured to engage the second projection.

 Alternatively or additionally to any of the examples above, wherein the engagement of the first projection with the second projection is configured to limit the radial expansion of the expandable portion.

20 Another example introducer includes:

 a hub; and

 a shaft including a tubular member and an expandable portion coupled to a distal end region of the tubular member, and wherein a proximal end region of the tubular member is coupled to a distal portion of the hub;

25 wherein the tubular member has a constant outer diameter from the distal end region to the proximal end region;

 wherein the expandable portion includes a first pair of leaflets and a second pair of leaflets spaced around a longitudinal axis of the expandable portion;

30 wherein the second pair of leaflets are spaced radially inward of an inner surface of the first pair of leaflets.

 Alternatively or additionally to any of the examples above, wherein the expandable portion is designed to shift between a first configuration and a second expanded configuration.

Alternatively or additionally to any of the examples above, wherein the first pair of leaflets includes a first leaflet and a second leaflet, wherein the first leaflet includes a first concave surface extending around the longitudinal axis, where the second leaflet includes a second concave surface extending around the longitudinal axis and wherein the first concave surface faces the second concave surface.

Alternatively or additionally to any of the examples above, wherein the second pair of leaflets includes a third leaflet and a fourth leaflet, wherein the third leaflet includes a third concave surface extending around the longitudinal axis, where the fourth leaflet includes a fourth concave surface extending around the longitudinal axis and wherein the third concave surface faces the fourth concave surface.

Alternatively or additionally to any of the examples above, wherein the first pair of leaflets is circumferentially offset from the second pair of leaflets.

Alternatively or additionally to any of the examples above, wherein the first leaflet, the second leaflet, the third leaflet and the fourth leaflet are configured to expand radially outward and away from one another when the expandable portion shifts from the first configuration to the second expanded configuration.

Another example introducer sheath includes:

a shaft including a tubular portion and an expandable portion coupled to the tubular portion;

wherein the expandable portion includes a first leaflet, a second leaflet, a third leaflet and a fourth leaflet spaced around the longitudinal axis of the expandable member;

wherein the first leaflet, the second leaflet, the third leaflet and the fourth leaflet are circumferentially offset from one another around the longitudinal axis; and

wherein the expandable portion is designed to shift between a first configuration and a second expanded configurations.

The above summary of some examples is not intended to describe each disclosed embodiment or every implementation of the present disclosure. The Figures, and Detailed Description, which follow, more particularly exemplify these examples.

BRIEF DESCRIPTION OF FIGURES

FIG. 1 is a perspective view of an example introducer;

FIG. 2 is a side view of the example introducer of FIG. 1;

FIG. 3 is a cross-sectional view taken along line 3-3 of FIG. 2;

FIG. 4 is a side view of the introducer of FIG. 1 in an expanded configuration;

FIG. 5 is a cross-sectional view taken along line 5-5 of FIG. 4;

5 FIG. 6 is an end view of another example introducer;

FIG. 7 is a side view of another example introducer;

FIG. 8 is a cross-sectional view taken along line 8-8 of FIG. 7;

FIGS. 9-11 illustrate an example medical device being inserted through an example introducer.

10 While the disclosure is amenable to various modifications and alternative forms, specifics thereof have been shown by way of example in the drawings and will be described in detail. It should be understood, however, that the intention is not to limit the disclosure to the particular examples described. On the contrary, the intention is to cover all modifications, equivalents, and alternatives falling within the spirit and scope
15 of the disclosure.

DETAILED DESCRIPTION

For the following defined terms, these definitions shall be applied, unless a different definition is given in the claims or elsewhere in this specification.

20 All numeric values are herein assumed to be modified by the term “about”, whether or not explicitly indicated. The term “about” generally refers to a range of numbers that one of skill in the art would consider equivalent to the recited value (e.g., having the same function or result). In many instances, the terms “about” may include numbers that are rounded to the nearest significant figure.

25 The recitation of numerical ranges by endpoints includes all numbers within that range (e.g. 1 to 5 includes 1, 1.5, 2, 2.75, 3, 3.80, 4, and 5).

As used in this specification and the appended claims, the singular forms “a”, “an”, and “the” include plural referents unless the content clearly dictates otherwise. As used in this specification and the appended claims, the term “or” is generally
30 employed in its sense including “and/or” unless the content clearly dictates otherwise.

It is noted that references in the specification to “an embodiment”, “some examples”, “other examples”, etc., indicate that the embodiment described may include one or more particular features, structures, and/or characteristics. However, such

recitations do not necessarily mean that all examples include the particular features, structures, and/or characteristics. Additionally, when particular features, structures, and/or characteristics are described in connection with one embodiment, it should be understood that such features, structures, and/or characteristics may also be used
5 connection with other examples whether or not explicitly described unless clearly stated to the contrary.

The following detailed description should be read with reference to the drawings in which similar elements in different drawings are numbered the same. The drawings, which are not necessarily to scale, depict illustrative examples and are not intended to
10 limit the scope of the disclosure.

In some instances, performing percutaneous medical procedures may require the insertion and/or maneuvering of relatively large medical devices through a patient's vasculature. However, inserting the medical device into the vasculature may result in undesirable forces being applied to the vessel walls. For example, as the medical device
15 passes into the vasculature, it may make undesirable contact with one or more vessel walls. This interference may cause injury to the vessel as the medical device is navigated into calcified or diseased vessels. Therefore, in some instances an introducer is utilized to facilitate the insertion of medical devices into the vessel. Further, vessel trauma resulting from forces applied to the vessel wall by a medical device may be
20 lessened by minimizing the size of an introducer used to access the vessel. Therefore, it may be desirable to design an introducer having a reduced insertion profile, yet capable of expansion when necessary (e.g., during the passage of a medical device therethrough). The following examples disclose an intravascular medical device including an expandable introducer, whereby the introducer is designed to expand from
25 a reduced profile, unexpanded configuration to an expanded configuration.

FIG. 1 illustrates an example expandable introducer (e.g., delivery sheath, access sheath, etc.) 10. The introducer 10 may include a hub 12 and a shaft 11. The shaft 11 may include a tubular member 14 and an expandable portion 20. The tubular member 14 may include a proximal end region 16 and a distal end region 18. Further,
30 the proximal end region 16 of the tubular member may be attached to a distal end of the hub member 12. Both the hub 12 and the tubular member 14 may include a lumen extending therethrough. The lumen extending through the hub 12 and the tubular member 14 (along with expandable portion 20) may be designed to permit a medical

device to pass from outside a patient's body, through the introducer 10 to a location inside the patient's body.

The hub 12 may include a hemostatic valve or seal disposed therein. The hemostatic valve or seal may prevent blood or other bodily fluid(s) from flowing proximally through the lumen of the tubular member 14. In at least some examples, the hub 12 may include a port in fluid communication with the lumen of the tubular member 14.

The expandable portion 20 of the introducer 10 may include a proximal end region 22 and a distal end region 24. Additionally, the proximal end region 22 of the expandable portion 20 may include a tapered region 26. In some examples, the tapered region 26 may be positioned distal to the distal end region 18 of the tubular member 14. In some examples at least a portion of the expandable portion 20 may have a substantially constant outer diameter which transitions into tapered portion 26. At least a portion of tapered portion 26 may have an outer diameter which is greater than the outer diameter of at least a portion of expandable portion 20 which is distal to the tapered portion 26. However, this is not intended to be limiting. It is contemplated that any portion of the introducer 10 may include any number of tapers, constant diameter regions or combinations thereof.

FIG. 1 further illustrates that introducer 10 may include one or more overlapping leaflets extending along the longitudinal axis 50 of the introducer 10. For example, FIG. 1 shows a first leaflet 28, a second leaflet 30, a third leaflet 32 and a fourth leaflet 34 positioned around the longitudinal axis 50 of the introducer 10. However, this is not intended to be limiting. For example, it is contemplated that the introducer 10 may include 1, 2, 3, 4, 5, 6 or more leaflets.

FIG. 1 further illustrates that each of the first leaflet 28, the second leaflet 30, the third leaflet 32 and the fourth leaflet 34 may extend from the distal end region 24 of the expandable portion 20 to the proximal end region 22 of the expandable portion. Further, the proximal ends of each of the first leaflet 28, the second leaflet 30, the third leaflet 32 and the fourth leaflet 34 may be attached to the distal end region 18 of the tubular member 14. Additionally, FIG. 1 illustrates that each of the first leaflet 28, the second leaflet 30, the third leaflet 32 and the fourth leaflet 34 may include a tapered region. However, this is not intended to be limiting. Rather, it is contemplated that none of the first leaflet 28, the second leaflet 30, the third leaflet 32 and the fourth

leaflet 34 may include a tapered portion. However, in other examples any combination of the first leaflet 28, the second leaflet 30, the third leaflet 32 and the fourth leaflet 34 may include a tapered portion.

Further, while FIG. 1 illustrates that the length of the first leaflet 28, the second
5 leaflet 30, the third leaflet 32 and the fourth leaflet 34 (as measured along the longitudinal axis 50) is substantially equivalent, it is contemplated that, in some examples, any of the first leaflet 28, the second leaflet 30, the third leaflet 32 and the fourth leaflet 34 may have variable lengths as measured along the longitudinal axis 50.

In some examples it may be desirable to add a tip member to the distal end of
10 any of the example introducers disclosed herein. FIG. 1 shows an example tip member 36 disposed along each of the first leaflet 28, the second leaflet 30, the third leaflet 32 and the fourth leaflet 34. The tip members 36 may be designed with a low durometer material. In some instances, a lower durometer material may provide the tip members 36 with the ability to radially expand (e.g., flex) outward and radially contract as a
15 variety of medical devices are advanced through the tip members 36. Further, the tip members 36 may include a taper. For example, the tip members 36 may taper from a first diameter to a second diameter at the distal end of introducer 10. While not intended to be limiting, in some examples the shape of the tip members 36 (in combination with one another) may resemble a bull-nose. Additionally, one or more of the tip members
20 36 may include a radiopaque material. The radiopaque material may allow the tip members 36 to be visualized by a clinician during a medical procedure. Additionally, while not illustrated in FIG. 1, it can be appreciated that a tip member 36 may be included on any combination of the first leaflet 28, the second leaflet 30, the third leaflet 32 and/or the fourth leaflet 34. In other words, in some examples the tip member 36
25 may not be included on all the individual leaflets.

FIG. 2 illustrates a side view of the introducer 10 shown in FIG. 1. As discussed above, FIG. 2 shows the first leaflet 28, the second leaflet 30 and the third leaflet 32 extending from the proximal end region 22 to the distal end region 24 (note that the fourth leaflet 34 extends from the proximal end region 22 to the distal end region 24,
30 but is hidden from view in FIG. 2 by the third leaflet 32). Additionally, FIG. 2 shows the tip members 36 disposed along the distal ends of the first leaflet 28, the second leaflet 30 and the third leaflet 32. As will be discussed in greater detail below, FIG. 2 illustrates that, in some examples, the first leaflet 28 may be spaced away from the

second leaflet 30 to define a first gap 38a between the first leaflet 28 and the second leaflet 30. It can be appreciated that the first gap 38a may extend along the longitudinal axis 50 from the proximal end region 22 to the distal end region 24 of the expandable member 20.

5 FIG. 3 is a cross-sectional view of the introducer 10 taken along line 3-3 of FIG. 2. As will be described in greater detail below, FIG. 3 represents a cross-section of expandable portion 20 in an unexpanded configuration.

As described above, FIG. 3 shows the first leaflet 28, the second leaflet 30, the third leaflet 32 and the fourth leaflet 34 circumferentially spaced around the longitudinal axis 50 of the introducer 10. As shown in FIG. 3, the first leaflet 28, the second leaflet 30, the third leaflet 32 and the fourth leaflet 34 may overlap and yet be circumferentially offset from one another around the longitudinal axis 50. In some instances, the first leaflet 28, the second leaflet 30, the third leaflet 32 and the fourth leaflet 34 may be offset substantially equidistant from one another. In other words, the degree for which each of the first leaflet 28, the second leaflet 30, the third leaflet 32 and the fourth leaflet 34 are circumferentially offset from one another may be substantially equivalent between individual leaflets. However, it is further contemplated that the leaflets may be spaced at variable distances around the longitudinal axis 50.

20 Additionally, it can be appreciated that, in some examples, the first leaflet 28 and the second leaflet 30 may define a first “pair” of leaflets, while the third leaflet 32 and the fourth leaflet 34 may define a second “pair” of leaflets. It can further be appreciated that the first pair of leaflets (e.g., the first leaflet 28 and the second leaflet 30) may be circumferentially offset from the second pair of leaflets (e.g., the third leaflet 32 and the second leaflet 34).

FIG. 3 further illustrates that the first leaflet 28 may include an inner surface 40 and the second leaflet 30 may include an inner surface 42. Further, each of the inner surface 40 and the inner surface 42 may be concave surfaces with respect to the central longitudinal axis 50. Additionally, the inner concave surface 40 and the inner concave surface 42 may face one another.

FIG. 3 further illustrates that the third leaflet 32 may include an inner surface 44 and the fourth leaflet 34 may include an inner surface 46. Further, each of the inner surface 44 and the inner surface 46 may be concave surfaces with respect to the central

longitudinal axis 50. Additionally, the inner concave surface 44 and the inner concave surface 46 may face one another.

As shown in FIG. 3, the outer surfaces of the first leaflet 28 and the second leaflet 30 (in combination) may define an outer extent depicted as “Y₁” while the outer surfaces of the third leaflet 32 and the fourth leaflet 34 (in combination) may include an outer extent depicted as “X₁.” It can be appreciated from FIG. 3 that the extent “Y₁” may be greater than the extent “X₁.” In other words, the third leaflet 32 and the fourth leaflet 34 (in combination) may be positioned radially inward of the first leaflet 28 and the second leaflet 30 (in combination).

As discussed above, FIG. 3 illustrates that the first leaflet 28 may be spaced away from the second leaflet 30 to define a first gap 38a (shown above with respect to FIG. 2) and a second gap 38b. Similarly, FIG. 3 illustrates that the third leaflet 32 may be spaced away from the fourth leaflet 34 to define a third gap 56a and a fourth gap 56b. It can be appreciated that the first gap 38a, the second gap 38b, the third gap 56a and the fourth gap 56b may extend along the longitudinal axis 50 from the distal end region to the proximal end region of the expandable member 20.

Additionally, FIG. 3 illustrates that the first leaflet 28 and the second leaflet 30 may include one or more projections 52 extending radially inward from the inner surface 40 of the first leaflet 28 and/or from the inner surface 42 of the second leaflet 30. For example, each of the first leaflet 28 and the second leaflet 30 may include a projection 52 positioned adjacent to a first lateral edge 58a and or a second lateral edge 58b. Similarly, the third leaflet 32 and the fourth leaflet 34 may include one or more projections 54 extending radially outward from the outer surface 48 of the third leaflet 32 and/or from the outer surface 51 of the fourth leaflet 34. For example, each of the third leaflet 32 and the fourth leaflet 34 may include a projection 54 positioned adjacent to a first lateral edge 60a and or a second lateral edge 60b. As will be described in greater detail below, the projections 52 extending radially inward from the first leaflet 28 and/or the second leaflet 30 may engage with the projections 54 extending radially outward from the third leaflet 32 and/or the fourth leaflet 34.

As discussed above, in some examples it may be desirable to design introducer 10 to permit a medical device (e.g., heart valve) to pass therethrough. For example, it may be desirable to permit a medical device to pass through hub 12, tubular member 14 and the expandable portion 20 (for example, to pass through introducer 10 while

being inserted into a body lumen). Further, in some instances it may be desirable to design introducer 10 to radially expand such that it can accommodate devices which have an outer diameter greater than the unexpanded inner diameters of hub 12, tubular member 14 and the expandable portion 20.

5 FIG. 4 and FIG. 5 represent the expandable portion 20 of the introducer 10 in an example expanded configuration. In particular, FIG. 4 illustrates an example configuration of the expandable portion 20 shown in FIG. 2 after the introducer 10 has been expanded radially outward. Further, FIG. 5 may represent the cross-section of the expandable member 20 shown in FIG. 4 (e.g., introducer 10 after it has been expanded
10 radially outward). In other words, the expandable portion 20 of the introducer 10 may shift between a first configuration and a second configuration, whereby the first configuration may represent an unexpanded configuration (illustrated in FIGS. 1-3) while the second configuration (illustrated in FIGS. 4-5) may represent an expanded configuration.

15 FIG. 4 shows the introducer 10 described above including the hub member 12, the tubular member 14 and the expandable portion 20. FIG. 4 illustrates the tip members 36 disposed along the distal end of the expandable portion 20. Further, FIG. 4 illustrates that in the expanded configuration, the first leaflet 28 and the second leaflet 30 may flex radially away from the longitudinal axis 50. In other words, both the first
20 leaflet 28 and the second leaflet 30 may flex away from one another, thereby increasing the gap 38a (shown in FIG. 2 and FIG. 3) to an expanded gap 39. As will be described in greater detail in FIG. 5, the third leaflet 32 and the fourth leaflet 34 may also flex radially away from the longitudinal axis 50, however, this is not shown in FIG. 4 as the third leaflet 32 and fourth leaflet 34 are flexing out and into the page, respectively. It
25 can be appreciated that the ability of the first leaflet 28, the second leaflet 30, the third leaflet 32 and the fourth leaflet 34 to flex radially away from the longitudinal axis 50 may permit a medical device to pass through the introducer 10.

As discussed above, FIG. 5 illustrates a cross-sectional view of the introducer 10 taken along line 5-5 of FIG. 4. FIG. 5 shows the first leaflet 28, the second leaflet
30 30, the third leaflet 32 and the fourth leaflet 34 flexed radially away from the longitudinal axis 50. As shown in FIG. 5, the first leaflet 28 and the second leaflet 30 may define an outer extent depicted as "Y₂." It can be appreciated that the expanded outer extent Y₂ may be greater than the unexpanded extent Y₁ shown in FIG. 3. Further,

the third leaflet 32 and the fourth leaflet 34 may define an outer extent depicted as “X₂.” It can be appreciated that the expanded outer extent X₂ may be greater than the unexpanded outer extent X₁ shown in FIG. 3.

FIG. 4 illustrates the first leaflet 28, the second leaflet 30, the third leaflet 32 and the fourth leaflet 34 flexed radially away from the longitudinal axis 50 such that the distal end region 24 of introducer may be substantially “cone-shaped.” However, this is not intended to be limiting. Rather, in other examples, it is contemplated that the first leaflet 28, the second leaflet 30, the third leaflet 32 and the fourth leaflet 34 may expand radially away from the longitudinal axis 50 such that each of the first leaflet 28, the second leaflet 30, the third leaflet 32 and the fourth leaflet 34 remain substantially parallel to one another along the longitudinal axis 50 while shifting between an unexpanded configuration and an expanded configuration. In yet other examples, it is contemplated that only a select portion of each of the first leaflet 28, the second leaflet 30, the third leaflet 32 and the fourth leaflet 34 may flex radially away from the longitudinal axis 50 as a medical device passes therethrough. For example, only the portion of the first leaflet 28, the second leaflet 30, the third leaflet 32 and the fourth leaflet 34 which contacts a medical device passing through the introducer 10 may expand radially outward.

It can be appreciated from FIG. 3 and FIG. 5 that as the first leaflet 28, the second leaflet 30, the third leaflet 32 and the fourth leaflet 34 shift between an unexpanded configuration and an expanded configuration, the outer surfaces of the third leaflet 32 and the fourth leaflet 34 may contact and slide along the inner surfaces of the first leaflet 28 and/or the second leaflet 30. The ability of the leaflets to slide along one another is beneficial as it allows the leaflets to expand and adapt to the diameter of a medical device passing therethrough without necessarily having to expand to a maximum extent.

In some instances it may be desirable to control the maximum radially outward expansion of the first leaflet 28, the second leaflet 30, the third leaflet 32 and the fourth leaflet 34. As described above, FIG. 5 illustrates the projections 52 (extending radially inward from the inner surface 40 of the first leaflet 28 and the inner surface 42 of the second leaflet 30) engaged with the projections 54 (extending radially outward from the outer surface 48 of the third leaflet 32 and the outer surface 51 of the fourth leaflet 34). It can be appreciated that the engagement of the projections 52 with the projections

54 may limit the radial outward expansion of the first leaflet 28, the second leaflet 30, the third leaflet 32 and the fourth leaflet 34. While FIG. 5 illustrates the projections 52 and projections 54 being substantially rectangular in shape, in some examples the projections 52 and projections 54 may include shapes other than the rectangular shape shown. For example, the projections 52 and projections 54 may be rounded, curved, ovular, circular, triangular or any other shape which permits the projections to engage and limit the outward radial expansion of the leaflets.

FIG. 6 illustrates a cross-sectional view of another example introducer 110. The introducer 110 may be similar in form and function to the introducer 10 illustrated above. For example, the introducer 110 may include a first leaflet 128, a second leaflet 130, a third leaflet 132 and a fourth leaflet 134 spaced circumferentially around a longitudinal axis 50 of the introducer 110. Further, the first leaflet 128, the second leaflet 130, the third leaflet 132 and the fourth leaflet 134 may overlap and yet be circumferentially offset from one another around the longitudinal axis 50 of the introducer 110. Additionally, FIG. 6 illustrates that the introducer 110 may include an outer covering 162. The outer covering 162 may extent along either a portion or the entire length of the first leaflet 128, the second leaflet 130, the third leaflet 132 and the fourth leaflet 134.

It can be appreciated that the outer covering 162 may be a flexible covering designed to expand radially outward as the first leaflet 128, the second leaflet 130, the third leaflet 132 and the fourth leaflet 134 expand radially outward. In some examples, the covering 162 may be designed to limit the radial expansion of the first leaflet 128, the second leaflet 130, the third leaflet 132 and the fourth leaflet 134. In other words, the covering 162 may be designed to radially compress against the first leaflet 128, the second leaflet 130, the third leaflet 132 and the fourth leaflet 134, thereby limiting the radial expansion of the leaflets. The outer covering 162 may include an elastomeric material (e.g., elastomeric polymer material). Further, while FIG. 6 illustrates the outer covering 162 may be disposed along the introducer 110, it can be appreciated that the covering 162 may be included on any example introducer disclosed herein.

FIG. 7 illustrates a side view of another example introducer 210. The introducer 210 may be similar in form and function to the introducer 10 illustrated above. For example, FIG. 7 shows a hub 212, a tubular member 214, an expandable portion 220 and a first leaflet 228, a second leaflet 230 and a third leaflet 232 (note that the fourth

leaflet 234 extends from the proximal end region 222 to the distal end region 224, but is hidden from view in FIG. 7 by the third leaflet 232 extending from the distal end region 224 to proximal end region 222). Additionally, FIG. 7 shows the tip members 236 disposed along the distal ends of the first leaflet 228, the second leaflet 230 and the third leaflet 232. Additionally, FIG. 7 illustrates that the first leaflet 228 may be spaced away from the second leaflet 230 to define a first gap 238a between the first leaflet 228 and the second leaflet 230. It can be appreciated that the first gap 238a may extend along the longitudinal axis 50 from the distal end region 224 to the proximal end region 222 of the expandable portion 220.

Further, FIG. 7 illustrates that in some examples the introducer 210 may include a first rib member 264a disposed along the outer surface 248 of the third leaflet 232. It can be appreciated that the rib member 264a may improve (e.g., increase) the column strength of the third leaflet 232. The rib member 264a may extend longitudinally along the third leaflet 232 from the proximal end region 222 to the distal end region 224 of the expandable portion 220. Additionally, FIG. 7 illustrates that the rib member 264a may be positioned along the outer surface 248 such that it is spaced within the gap 238a.

FIG. 8 illustrates a cross-sectional view taken along line 8-8 of FIG. 7. As discussed above, FIG. 8 illustrates the rib member 264a extending radially outward from the outer surface 248 of the third leaflet 232. As discussed above, FIG. 8 further illustrates that the rib member 264a is positioned on the outer surface 248 of the third leaflet 232 such that it lies within the gap 238a between the first leaflet 228 and the second leaflet 230.

Additionally, FIG. 8 illustrates that, in some examples, a second rib member 264b may be disposed along the outer surface 251 of the fourth leaflet 234. Similarly to that described above with respect to the rib member 264a, the rib member 264b may be positioned on the outer surface 251 of the fourth leaflet 234 such that it lies within a second gap 238b between the first leaflet 228 and the second leaflet 230. It can be appreciated that the rib member 264b may improve (e.g., increase) the column strength of the fourth leaflet 234.

Further, it is contemplated that the inner surface and/or outer surface of tubular member 14 or any of the leaflets defining the expandable member 20 may include one or more layers or coatings, such as a lubricious coating, a hydrophilic coating, a hydrophobic coating, or other suitable coatings, and the like, or may include a lubricant

disposed thereon. Additionally, it is contemplated that in some examples contemplated herein, a liner may be disposed along the inner surface of tubular member 14 or any of the leaflets defining the expendable member 20. It is further contemplated that the liner may extend along the length of tubular member 14 or any of the leaflets defining the
5 expendable member 20.

In some examples, the example introducers described herein may be disposed about or inserted over a guidewire (not shown), although the guidewire is not required. As discussed above, in some examples the hub and the tubular member of an example introducer may have an inner diameter or extent sufficient to accept a medical device
10 passing therethrough, while the expandable portion of the introducer may have an inner diameter or radial extent in a relaxed condition that is less than a maximum outer diameter or extent of the medical device.

FIGS. 9-11 illustrate a method of use of introducer 10. While FIGS. 9-11 illustrate the use of the introducer 10, it can be appreciated that the methodology may
15 apply to any of the example introducers disclosed herein.

FIG. 9 shows that an elongate medical device 53 (e.g., heart valve) may be inserted into a lumen (not shown for simplicity) of the introducer 10 and advanced distally toward the distal end of introducer 10. For example, the medical device may be advanced through the hub 12 and into the tubular member 14. It is noted that the
20 first leaflet 28, the second leaflet 30, the third leaflet 32 and the fourth leaflet 34 (not shown is it is hidden by the first leaflet 28, second leaflet 30 and third leaflet 32) have not yet expanded in FIG. 9. As described above, FIG. 9 illustrates the unexpanded gap 38a between the first leaflet 28 and the second leaflet 30.

FIG. 10 illustrates that after passing through the tubular member 14, the medical
25 device 53 may engage with the distal end region 22 of the expandable portion 20. It is noted that the first leaflet 28, the second leaflet 30, the third leaflet 32 and the fourth leaflet 34 (not shown is it is hidden by the first leaflet 28, second leaflet 30 and third leaflet 32) have not yet expanded in FIG. 10. As described above, FIG. 10 illustrates the unexpanded gap 38a between the first leaflet 28 and the second leaflet 30.

FIG. 11 illustrates that as the medical device 53 is advanced in a proximal-to-
30 distal direction, the medical device 53 may exert a radially outward force on the inner surfaces of the first leaflet 28, the second leaflet 30, the third leaflet 32 and the fourth leaflet 34 (not shown is it is hidden by the first leaflet 28, second leaflet 30 and third

leaflet 32). This radially outward force may cause the first leaflet 28, the second leaflet 30, the third leaflet 32 and the fourth leaflet 34 to flex radially away (e.g., radially outward) from the longitudinal axis 50 of the introducer 10 as the medical device 53 is advanced distally through the expandable portion 20. The radial expansion of the expandable portion 20 (including the first leaflet 28, the second leaflet 30, the third leaflet 32 and the fourth leaflet 34) from an unexpanded configuration to an expanded configuration illustrated in FIG. 11 may correspond to the expansion from an unexpanded to an expanded configuration of the first leaflet 28, the second leaflet 30, the third leaflet 32 and the fourth leaflet 34 illustrated and described above with respect to FIGS. 3-5. Accordingly, FIG. 11 illustrates the expanded gap 39 (described above with respect to FIG. 4) between the first leaflet 28 and the second leaflet 30.

Further, the expansion of the expandable portion 20 of the introducer 10 shown in above from an unexpanded configuration to an expanded configuration may be variable. For example, the diameter of the unexpanded expandable portion 20 of the introducer 10 may increase to an expanded diameter, after which, it may contract to a diameter that is greater than the diameter of the unexpanded configuration. However, this is not intended to be limiting. It is contemplated that once the unexpanded expandable portion 20 is expanded, it may remain expanded or it may return to any diameter less than the expanded diameter (including a diameter that is less than the unexpanded diameter).

In some examples, introducer 10 (or other example introducers and components thereof disclosed herein) may be made from materials such as metals, metal alloys, polymers, ceramics, metal-polymer composites, or other suitable materials, and the like. Some examples of suitable materials may include metallic materials such as stainless steels (e.g. 304v stainless steel or 316L stainless steel), nickel-titanium alloys (e.g., nitinol, such as super elastic or linear elastic nitinol), nickel-chromium alloys, nickel-chromium-iron alloys, cobalt alloys, nickel, titanium, platinum, or alternatively, a polymeric material, such as a high performance polymer, or other suitable materials, and the like. The word nitinol was coined by a group of researchers at the United States Naval Ordinance Laboratory (NOL) who were the first to observe the shape memory behavior of this material. The word nitinol is an acronym including the chemical symbol for nickel (Ni), the chemical symbol for titanium (Ti), and an acronym identifying the Naval Ordinance Laboratory (NOL).

In some examples, the introducer 10 (or other example introducers and components thereof disclosed herein) may be made from materials such as, for example, a polymeric material, a ceramic, a metal, a metal alloy, a metal-polymer composite, or the like. Examples of suitable polymers may include polyurethane, a polyether-ester such as ARNITEL® available from DSM Engineering Plastics, a polyester such as HYTREL® available from DuPont, a linear low density polyethylene such as REXELL®, a polyamide such as DURETHAN® available from Bayer or CRISTAMID® available from Elf Atochem, an elastomeric polyamide, a block polyamide/ether, a polyether block amide such as PEBA available under the trade name PEBAX®, silicones, polyethylene, Marlex high-density polyethylene, polyetheretherketone (PEEK), polyimide (PI), and polyetherimide (PEI), a liquid crystal polymer (LCP) alone or blended with other materials. In some examples, a suitable polymeric material may have a yield strain of at least 20%, at least 30%, at least 40%, at least 50%, or more. In some examples, the sheath, the membrane, and/or the plurality of corrugations may be made from a material having a low coefficient of friction. In some examples, the sheath, the membrane, and/or the plurality of corrugations may be formed from a fluoropolymer, such as polytetrafluoroethylene (PTFE) or fluorinated ethylene propylene (FEP).

Portions of introducer 10 (or other example introducers and components thereof disclosed herein) may be made of, may be doped with, may include a layer of, or otherwise may include a radiopaque material. Radiopaque materials are understood to be materials capable of producing a relatively bright image on a fluoroscopy screen or another imaging technique such as X-ray during a medical procedure. This relatively bright image aids the user of device in determining its location. For example, one or more of the elements described above (i.e., the sheath, the membrane, the medical device, etc.) may include or be formed from a radiopaque material. Suitable materials can include, but are not limited to, bismuth subcarbonate, iodine, gold, platinum, palladium, tantalum, tungsten or tungsten alloy, and the like.

It should be understood that although the above discussion was focused on percutaneous medical procedures within the vasculature of a patient, other examples or methods in accordance with the disclosure can be adapted and configured for use in other parts of the anatomy of a patient. For example, devices and methods in accordance with the disclosure can be adapted for use in the digestive or gastrointestinal

tract, such as in the mouth, throat, small and large intestine, colon, rectum, and the like. For another example, devices and methods can be adapted and configured for use within the respiratory tract, such as in the mouth, nose, throat, bronchial passages, nasal passages, lungs, and the like. Similarly, the devices and methods described herein with
5 respect to percutaneous deployment may be used in other types of surgical procedures as appropriate. For example, in some examples, the devices may be deployed in a non-percutaneous procedure. Devices and methods in accordance with the disclosure can also be adapted and configured for other uses within the anatomy.

It should be understood that this disclosure is, in many respects, only illustrative.
10 Changes may be made in details, particularly in matters of shape, size, and arrangement of steps without exceeding the scope of the disclosure. The disclosure's scope is, of course, defined in the language in which the appended claims are expressed.

CLAIMS

What is claimed is:

1. An introducer sheath, comprising:
a shaft including a tubular portion, an expandable portion coupled to the tubular portion and a longitudinal axis;
wherein the expandable portion includes a first pair of leaflets and a second pair of leaflets, and wherein both the first pair of leaflets and the second pair of leaflets extend along the longitudinal axis;
wherein the second pair of leaflets are spaced radially inward of an inner surface of the first pair of leaflets; and
wherein the expandable portion is designed to shift between a first configuration and a second expanded configuration.

2. The introducer of claim 1, wherein the first pair of leaflets includes a first leaflet and a second leaflet, wherein the first leaflet includes a first concave surface extending partially around the longitudinal axis, where the second leaflet includes a second concave surface extending partially around the longitudinal axis and wherein the first concave surface faces the second concave surface.

3. The introducer of any one of claims 1-2, wherein the second pair of leaflets includes a third leaflet and a fourth leaflet, wherein the third leaflet includes a third concave surface extending partially around the longitudinal axis, where the fourth leaflet includes a fourth concave surface extending partially around the longitudinal axis and wherein the third concave surface faces the fourth concave surface.

4. The introducer of any one of claims 1-3, wherein the first pair of leaflets are circumferentially offset from the second pair of leaflets.

5. The introducer of any one of claims 2-4, wherein the first leaflet is spaced away from the second leaflet to form a first gap extending along the longitudinal axis and a second gap extending along the longitudinal axis.

6. The introducer of any one of claims 3-5, wherein the third leaflet is spaced away from the fourth leaflet to form a third gap extending along the longitudinal axis and a fourth gap extending along the longitudinal axis.

7. The introducer of any one of claims 2-6, wherein the first leaflet and the second leaflet are configured to flex radially outward and away from one another when the expandable portion shifts from the first configuration to the second expanded configuration.

8. The introducer of any one of claims 3-7, wherein the third leaflet and the fourth leaflet are configured to flex radially outward and away from one another when the expandable portion shifts from the first configuration to the second expanded configuration.

9. The introducer of any one of claims 3-8, wherein the first and second leaflets include an inner surface and wherein the third and fourth leaflets include an outer surface, and wherein the outer surface of the third and fourth leaflets are configured to slide along the inner surfaces of the first and second leaflets when the expandable portion shifts from the first configuration to the second expanded configuration.

10. The introducer of any one of claims 3-9, wherein the third leaflet includes an outer surface and a first rib member disposed along the outer surface of the third leaflet, and wherein the fourth leaflet includes an outer surface and a second rib member disposed along the outer surface of the fourth leaflet.

11. The introducer of claim 10, wherein the first rib member is positioned within the first gap and wherein the second rib member is positioned within the second gap.

12. The introducer of any one of claims 3-11, wherein the first leaflet includes a first projection extending radially inward from an inner surface of the first leaflet, and wherein the third leaflet includes a second projection extending radially outward from an outer surface of the third leaflet, and wherein the first projection is configured to engage the second projection.

13. The introducer of claim 12, wherein the engagement of the first projection with the second projection is configured to limit the radial expansion of the expandable portion.

14. An introducer, comprising:
a hub; and
a shaft including a tubular member and an expandable portion coupled to a distal end region of the tubular member, and wherein a proximal end region of the tubular member is coupled to a distal portion of the hub;
wherein the tubular member has a constant outer diameter from the distal end region to the proximal end region;
wherein the expandable portion includes a first pair of leaflets and a second pair of leaflets spaced around a longitudinal axis of the expandable portion;
wherein the second pair of leaflets are spaced radially inward of an inner surface of the first pair of leaflets.

15. The introducer of claim 14, wherein the expandable portion is designed to shift between a first configuration and a second expanded configuration.

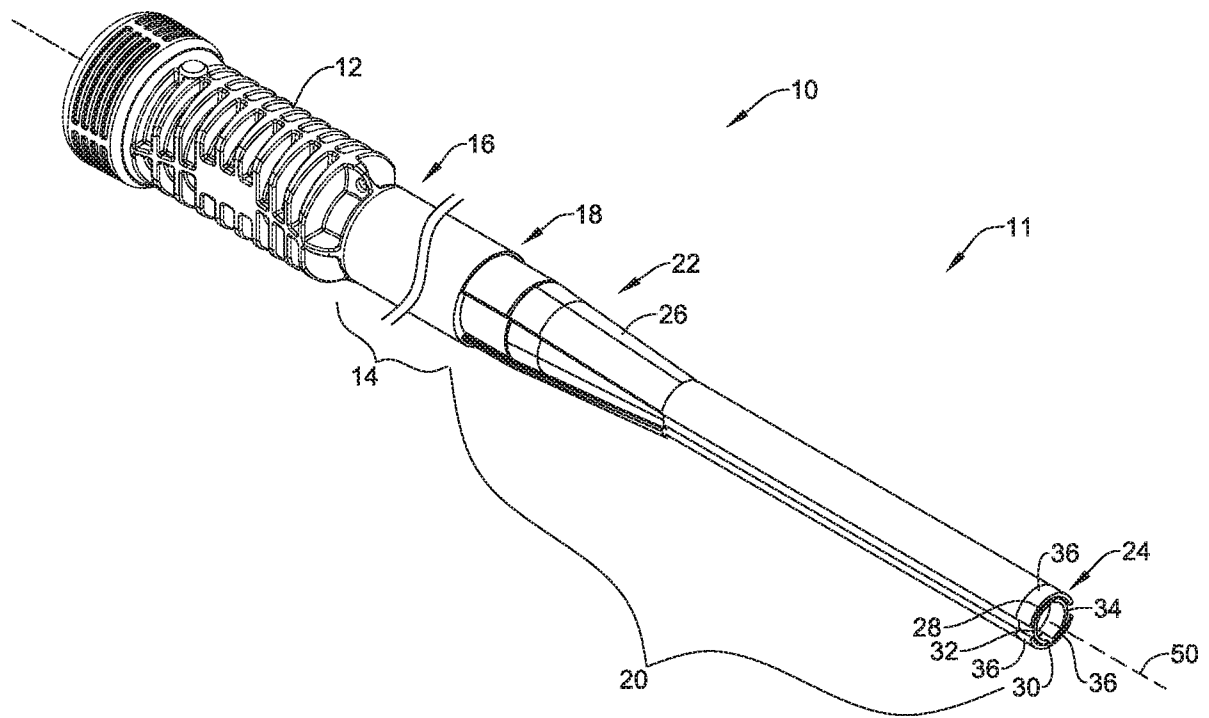

FIG. 1

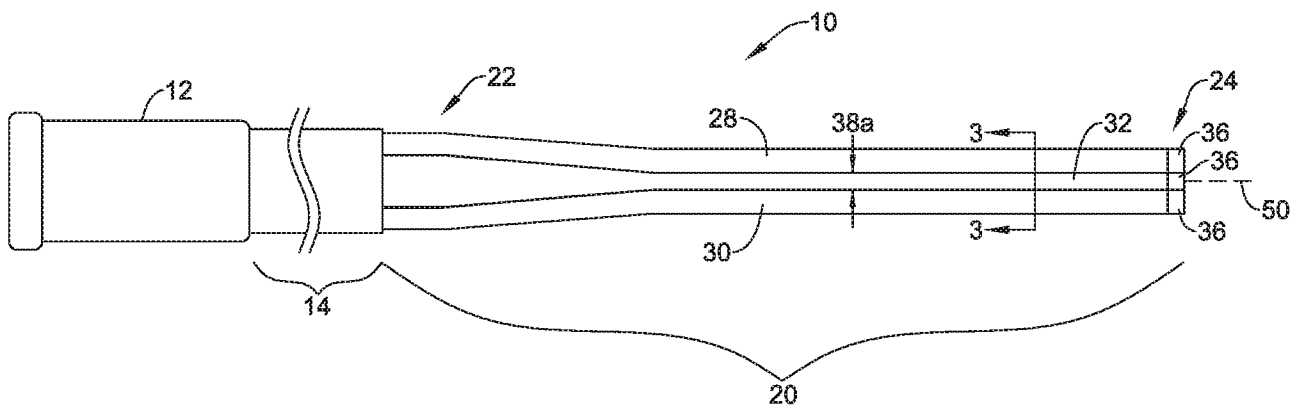

FIG. 2

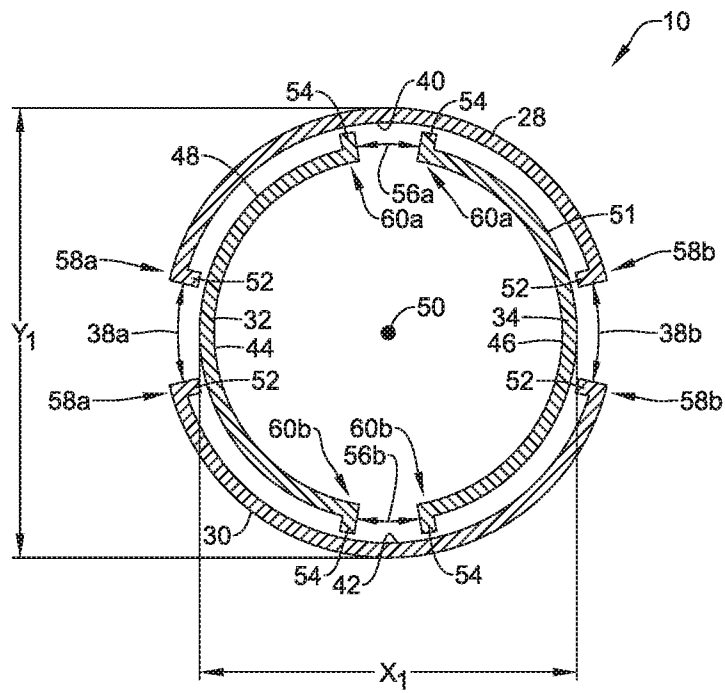

FIG. 3

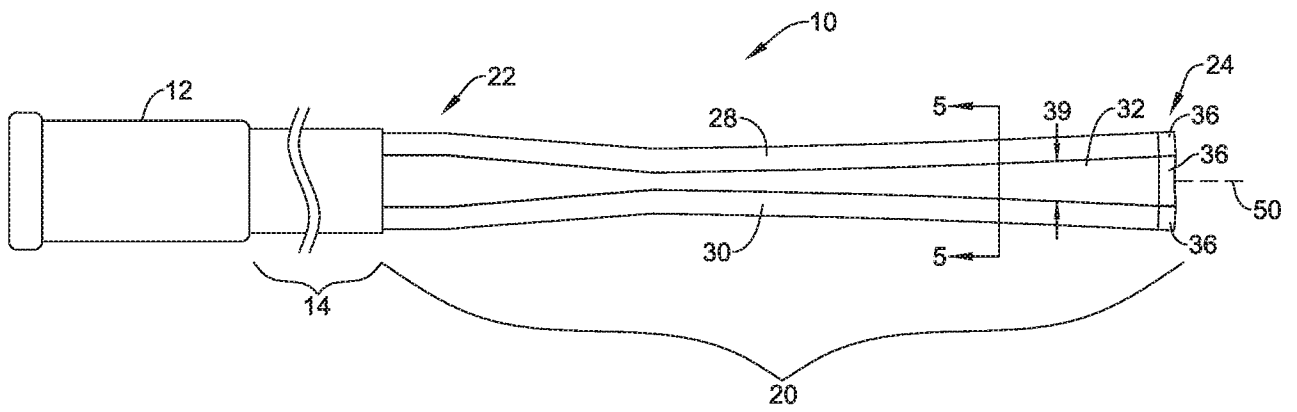

FIG. 4

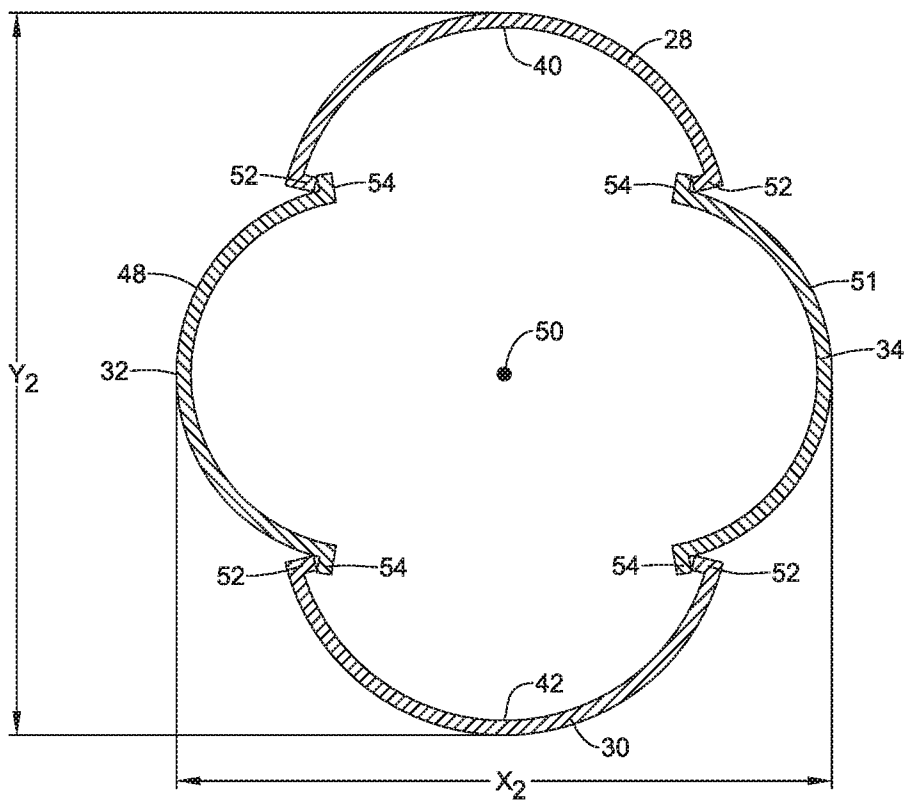

FIG. 5

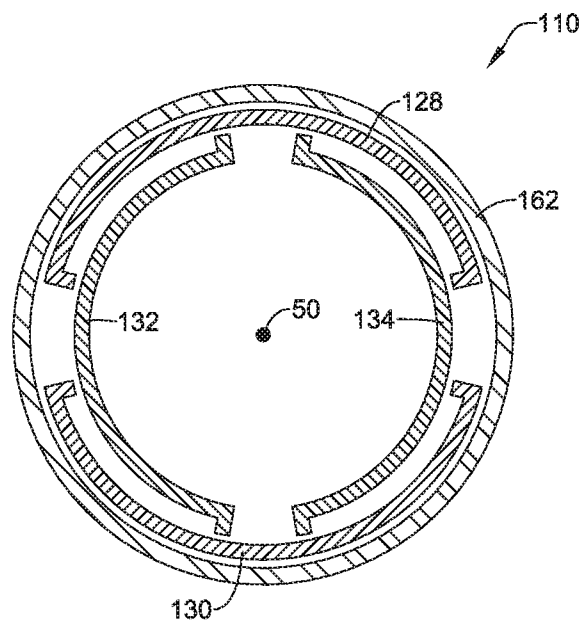

FIG. 6

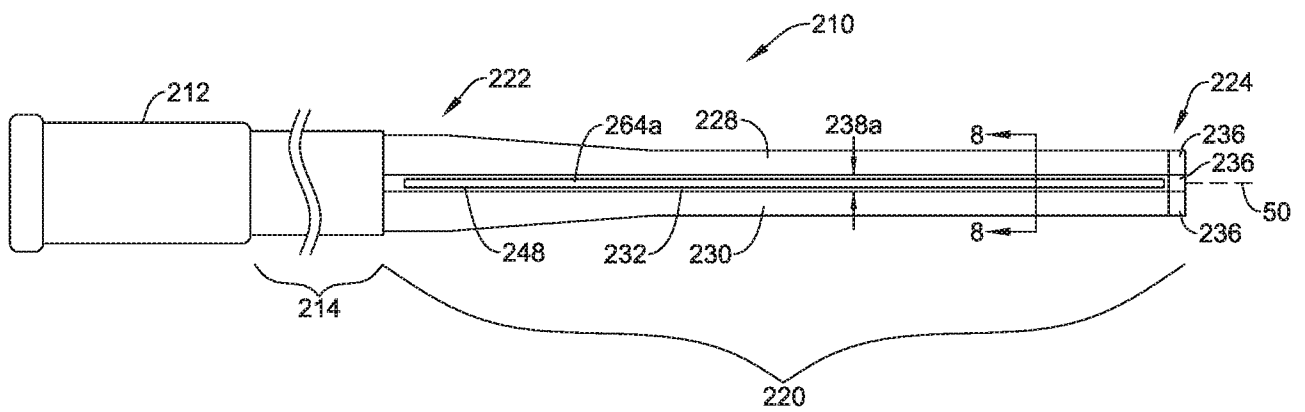

FIG. 7

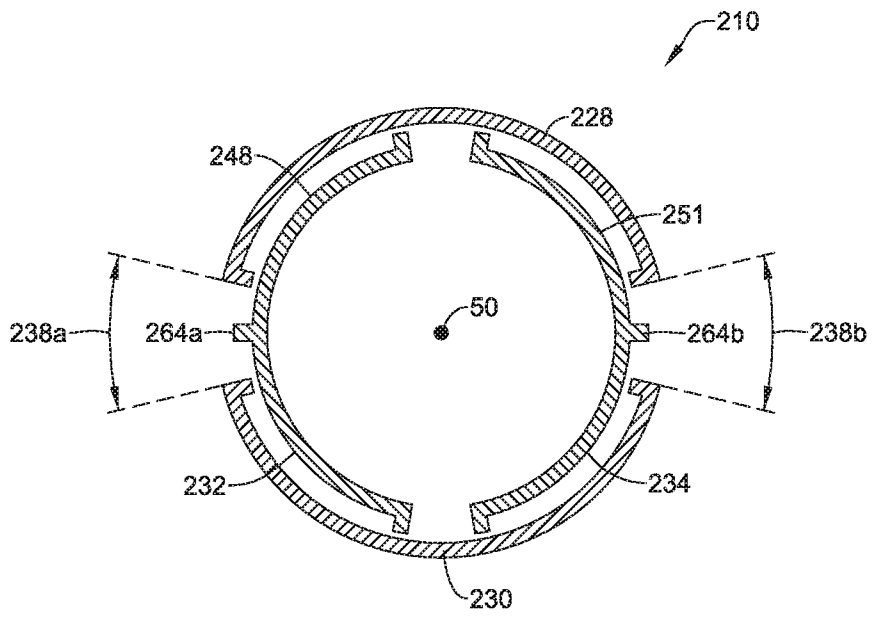

FIG. 8

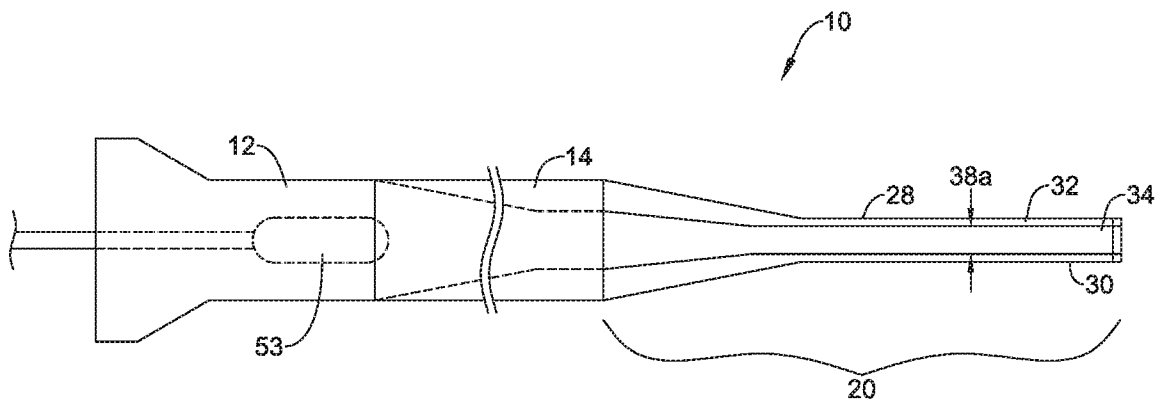

FIG. 9

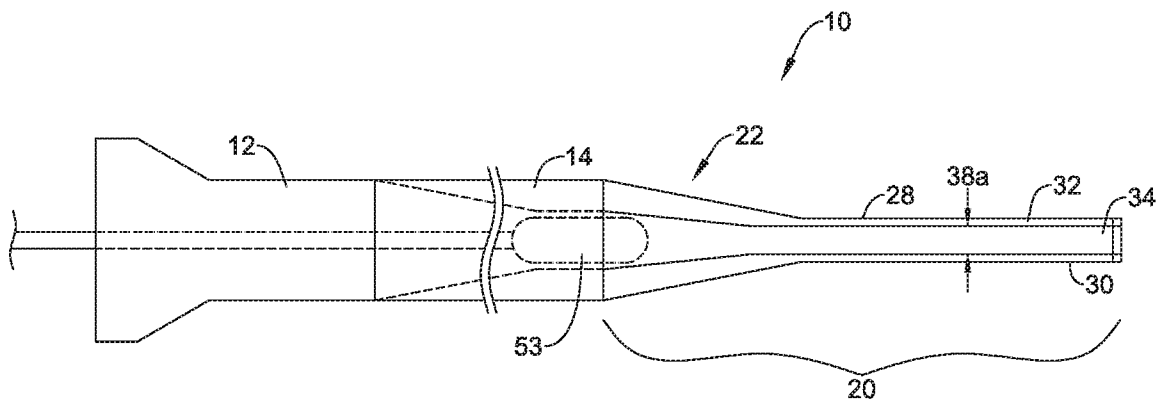

FIG. 10

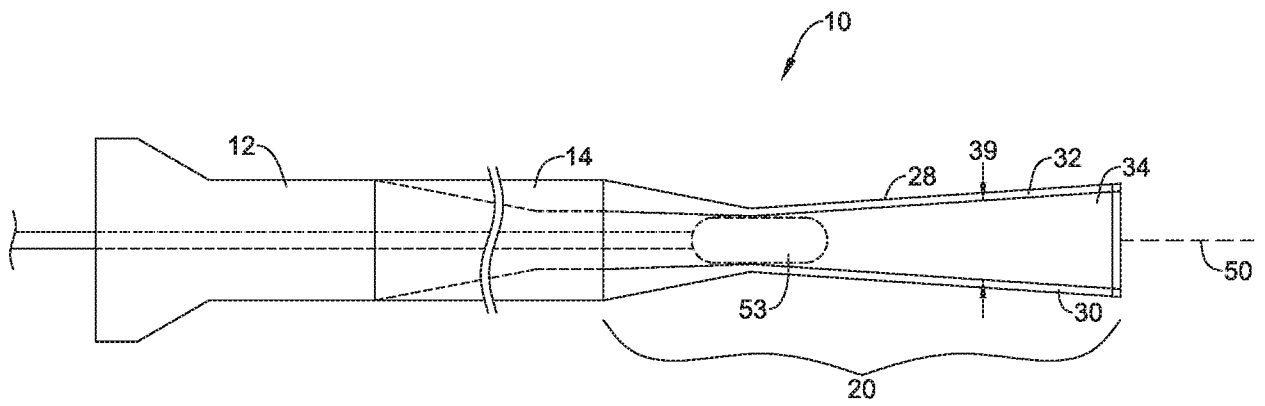

FIG. 11

INTERNATIONAL SEARCH REPORT

International application No
PCT/US2019/018185

A. CLASSIFICATION OF SUBJECT MATTER
INV. A61M25/06
ADD.

According to International Patent Classification (IPC) or to both national classification and IPC

B. FIELDS SEARCHED

Minimum documentation searched (classification system followed by classification symbols)
A61M

Documentation searched other than minimum documentation to the extent that such documents are included in the fields searched

Electronic data base consulted during the international search (name of data base and, where practicable, search terms used)
EPO-Internal, WPI Data

Category*	Citation of document, with indication, where appropriate, of the relevant passages	Relevant to claim No.
X	US 2017/014156 A1 (STEFFEN DENNIS L [US]) 19 January 2017 (2017-01-19) paragraphs [0019], [0020], [0044], [0049]; figures 1,10 -----	1-9,14, 15
A	WO 98/29026 A2 (IMAGYN MEDICAL TECHNOLOGIES IN [US]) 9 July 1998 (1998-07-09) page 10, line 22 - page 11, line 31; figures 3a-5e -----	1-15
A	US 2015/073333 A1 (KNOWLES ROBERT C [US]) 12 March 2015 (2015-03-12) paragraph [0048]; figures 2b,2c -----	1-15

Further documents are listed in the continuation of Box C.

See patent family annex.

* Special categories of cited documents :

- "A" document defining the general state of the art which is not considered to be of particular relevance
- "E" earlier application or patent but published on or after the international filing date
- "L" document which may throw doubts on priority claim(s) or which is cited to establish the publication date of another citation or other special reason (as specified)
- "O" document referring to an oral disclosure, use, exhibition or other means
- "P" document published prior to the international filing date but later than the priority date claimed

- "T" later document published after the international filing date or priority date and not in conflict with the application but cited to understand the principle or theory underlying the invention
- "X" document of particular relevance; the claimed invention cannot be considered novel or cannot be considered to involve an inventive step when the document is taken alone
- "Y" document of particular relevance; the claimed invention cannot be considered to involve an inventive step when the document is combined with one or more other such documents, such combination being obvious to a person skilled in the art
- "&" document member of the same patent family

Date of the actual completion of the international search 30 April 2019	Date of mailing of the international search report 10/05/2019
---	---

Name and mailing address of the ISA/ European Patent Office, P.B. 5818 Patentlaan 2 NL - 2280 HV Rijswijk Tel. (+31-70) 340-2040, Fax: (+31-70) 340-3016	Authorized officer Espuch, Antonio
--	--

INTERNATIONAL SEARCH REPORT

Information on patent family members

International application No

PCT/US2019/018185

Patent document cited in search report	Publication date	Patent family member(s)	Publication date
US 2017014156	A1	19-01-2017	NONE

WO 9829026	A2	09-07-1998	AU 5621198 A 31-07-1998
		WO 9829026 A2	09-07-1998

US 2015073333	A1	12-03-2015	NONE
