



- (51) International Patent Classification:  
F04C 29/02 (2006.01)
- (21) International Application Number:  
PCT/CN2014/080951
- (22) International Filing Date:  
27 June 2014 (27.06.2014)
- (25) Filing Language: English
- (26) Publication Language: English
- (30) Priority Data:  
61/840,153 27 June 2013 (27.06.2013) US
- (71) Applicant (for all designated States except US): EMERSON CLIMATE TECHNOLOGIES, INC. [US/US];  
1675 West Campbell Road, Sidney, Ohio 45365-0669 (US).
- (72) Inventors; and
- (71) Applicants (for US only): ZHOU, Guangyong [CN/CN];  
Emerson Building, International Science Park, No. 1355

Jinji Lake Avenue, Suzhou Industrial Park, Jiangsu 215021 (CN). **SUN, Qingfeng** [CN/CN]; Emerson Building, International Science Park, No. 1355 Jinji Lake Avenue, Suzhou Industrial Park, Jiangsu 215021 (CN). **SHU, Hongfei** [CN/CN]; Emerson Building, International Science Park, No. 1355 Jinji Lake Avenue, Suzhou Industrial Park, Jiangsu 215021 (CN). **AKEI, Masao** [US/US]; 2042 Sandy Lane, Lima, Ohio 45806 (US). **DOEPKER, Roy J.** [US/US]; 808 Jeannie Way, Miamisburg, Ohio 45342 (US).

(74) Agent: UNITALEN ATTORNEYS AT LAW; 7th Floor, Scitech Place, No. 22 Jian Guo Men Wai Ave., Chao Yang District, Beijing 100004 (CN).

(81) Designated States (unless otherwise indicated, for every kind of national protection available): AE, AG, AL, AM, AO, AT, AU, AZ, BA, BB, BG, BH, BN, BR, BW, BY, BZ, CA, CH, CL, CN, CO, CR, CU, CZ, DE, DK, DM, DO, DZ, EC, EE, EG, ES, FI, GB, GD, GE, GH, GM, GT, HN, HR, HU, ID, IL, IN, IR, IS, JP, KE, KG, KN, KP, KR, KZ, LA, LC, LK, LR, LS, LT, LU, LY, MA, MD, ME,

[Continued on next page]

(54) Title: SCROLL COMPRESSOR WITH OIL MANAGEMENT SYSTEM

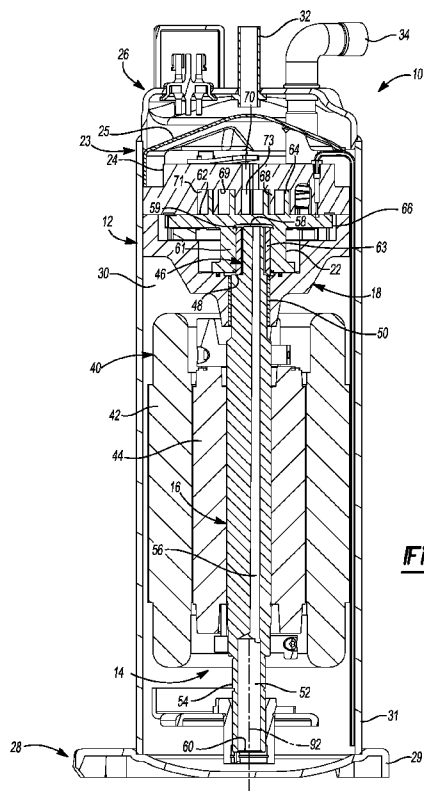


Fig-1

(57) Abstract: A compressor (10) is provided and may include a shell (12), a main bearing housing (18) disposed within the shell (12), a driveshaft (16), a non-orbiting scroll member (24), and an orbiting scroll member (22). The driveshaft (16) may be supported by the main bearing housing (18). The non-orbiting scroll member (24) may be coupled to the main bearing housing (18) and may include a first lubricant supply path in fluid communication with a lubricant source. The orbiting scroll member (22) may be rotatably coupled to the driveshaft (16) and may be meshingly engaged with the non-orbiting scroll member (24). The orbiting scroll member (22) may include a recess (96) that is moved between a first position in fluid communication with the first lubricant supply path and a second position fluidly isolated from the first lubricant supply path.



MG, MK, MN, MW, MX, MY, MZ, NA, NG, NI, NO, NZ, OM, PA, PE, PG, PH, PL, PT, QA, RO, RS, RU, RW, SA, SC, SD, SE, SG, SK, SL, SM, ST, SV, SY, TH, TJ, TM, TN, TR, TT, TZ, UA, UG, US, UZ, VC, VN, ZA, ZM, ZW.

TM), European (AL, AT, BE, BG, CH, CY, CZ, DE, DK, EE, ES, FI, FR, GB, GR, HR, HU, IE, IS, IT, LT, LU, LV, MC, MK, MT, NL, NO, PL, PT, RO, RS, SE, SI, SK, SM, TR), OAPI (BF, BJ, CF, CG, CI, CM, GA, GN, GQ, GW, KM, ML, MR, NE, SN, TD, TG).

**(84) Designated States** (*unless otherwise indicated, for every kind of regional protection available*): ARIPO (BW, GH, GM, KE, LR, LS, MW, MZ, NA, RW, SD, SL, SZ, TZ, UG, ZM, ZW), Eurasian (AM, AZ, BY, KG, KZ, RU, TJ,

**Published:**

— *with international search report (Art. 21(3))*

## SCROLL COMPRESSOR WITH OIL MANAGEMENT SYSTEM

### CROSS-REFERENCE TO RELATED APPLICATIONS

**[0001]** This application claims the benefit of U.S. Provisional Application No. 61/840,153, filed on June 27, 2013. The entire disclosure of the above application is incorporated herein by reference.

### FIELD

**[0002]** The present disclosure relates to an oil-management system for a scroll compressor.

### BACKGROUND

**[0003]** This section provides background information related to the present disclosure which is not necessarily prior art.

**[0004]** Scroll compressors are used in applications such as refrigeration systems, air conditioning systems, and heat pump systems to pressurize and, thus, circulate refrigerant within each system.

**[0005]** As the scroll compressor operates, an orbiting scroll member having an orbiting scroll member wrap orbits with respect to a non-orbiting scroll member having a non-orbiting scroll member wrap to make moving line contacts between flanks of the respective scroll wraps. In so doing, the orbiting scroll member and the non-orbiting scroll member cooperate to define moving, crescent-shaped pockets of vapor refrigerant. A volume of the fluid pockets decreases as the pockets move toward a center of the scroll members, thereby

compressing the vapor refrigerant disposed therein from a suction pressure to a discharge pressure.

**[0006]** During operation, lubrication is provided to many of the moving components of the scroll compressor in an effort to reduce wear, improve performance, and, in some instances, to cool one or more components. For example, lubrication in the form of oil may be provided to the orbiting scroll member and to the non-orbiting scroll member such that flanks of the orbiting scroll spiral wrap and flanks of the fixed scroll spiral wrap are lubricated during operation. Such lubrication may be returned to a sump of the compressor and in so doing may come in contact with a motor of the compressor, thereby cooling the motor to a desired temperature.

**[0007]** While lubrication is typically used in a scroll compressor to improve performance and longevity, such lubrication is typically separated from vapor refrigerant located within the compressor to improve compressor performance and efficiency.

## SUMMARY

**[0008]** This section provides a general summary of the disclosure, and is not a comprehensive disclosure of its full scope or all of its features.

**[0009]** A compressor is provided and may include a shell, a main bearing housing disposed within the shell, a driveshaft, a non-orbiting scroll member, and an orbiting scroll member. The driveshaft may be supported by the main bearing housing. The non-orbiting scroll member may be coupled to

the main bearing housing and may include a first lubricant supply path in fluid communication with a lubricant source. The orbiting scroll member may be rotatably coupled to the driveshaft and may be meshingly engaged with the non-orbiting scroll member. The orbiting scroll member may include a recess that is moved between a first position in fluid communication with the first lubricant supply path and a second position fluidly isolated from the first lubricant supply path.

**[0010]** In another configuration, a compressor is provided and may include a shell, a main bearing housing disposed within the shell, a driveshaft, a non-orbiting scroll member, and an orbiting scroll member. The driveshaft may be supported by the main bearing housing. The non-orbiting scroll member may be coupled to the main bearing housing and may include a first surface defining a first lubricant recess. The orbiting scroll member may be rotatably coupled to the driveshaft and may be meshingly engaged with the non-orbiting scroll member. The orbiting scroll member may include a second lubricant recess in fluid communication with a lubricant source and movable between a first position in fluid communication with the first lubricant recess and a second position fluidly isolated from the first lubricant recess.

**[0011]** Further areas of applicability will become apparent from the description provided herein. The description and specific examples in this summary are intended for purposes of illustration only and are not intended to limit the scope of the present disclosure.

## DRAWINGS

**[0012]** The drawings described herein are for illustrative purposes only of selected embodiments and not all possible implementations, and are not intended to limit the scope of the present disclosure.

**[0013]** FIG. 1 is a cross-sectional view of a compressor in accordance with the present disclosure;

**[0014]** FIG. 2 is a top perspective view of a separation baffle of the compressor of FIG. 1;

**[0015]** FIG. 3 is a bottom perspective view of the separation baffle of FIG. 2;

**[0016]** FIG. 4 is a partial cross-sectional view of the compressor of FIG. 1, showing an oil management system in a first orientation;

**[0017]** FIG. 5 is a partial cross-sectional view of the compressor of FIG. 1, showing the oil management system of FIG. 4 in a second orientation;

**[0018]** FIG. 6 is a partial cross-sectional view of the compressor of FIG. 1, showing another oil management system in accordance with the principles of the present disclosure;

**[0019]** FIG. 7 is a partial cross-sectional view of the compressor of FIG. 1, showing another oil management system in accordance with the principles of the present disclosure;

**[0020]** FIG. 8 is a partial cross-sectional view of the compressor of FIG. 1, showing another oil management system in accordance with the principles of the present disclosure, and in a first orientation;

**[0021]** FIG. 9 is a partial cross-sectional view of the compressor of FIG. 1, showing the oil management system of FIG. 8 in a second orientation;

**[0022]** FIG. 10 is a top view of the oil management system of FIG. 8 in the first orientation;

**[0023]** FIG. 11 is a top view of the oil management system of FIG. 8 in the second orientation;

**[0024]** FIG. 12 is a top view of the oil management system of FIG. 8 in a third orientation;

**[0025]** FIG. 13 is a top view of a lower surface of a non-orbiting scroll including another oil management system in accordance with the principles of the present disclosure; and

**[0026]** FIG. 14 is a top plan view of an upper surface of an orbiting scroll including the oil management system of FIG. 13.

**[0027]** Corresponding reference numerals indicate corresponding parts throughout the several views of the drawings.

#### DETAILED DESCRIPTION

**[0028]** Example embodiments will now be described more fully with reference to the accompanying drawings.

**[0029]** Example embodiments are provided so that this disclosure will be thorough, and will fully convey the scope to those who are skilled in the art. Numerous specific details are set forth such as examples of specific components, devices, and methods, to provide a thorough understanding of embodiments of the present disclosure. It will be apparent to those skilled in the art that specific details need not be employed, that example embodiments may be embodied in many different forms and that neither should be construed to limit the scope of the disclosure. In some example embodiments, well-known processes, well-known device structures, and well-known technologies are not described in detail.

**[0030]** The terminology used herein is for the purpose of describing particular example embodiments only and is not intended to be limiting. As used herein, the singular forms "a," "an," and "the" may be intended to include the plural forms as well, unless the context clearly indicates otherwise. The terms "comprises," "comprising," "including," and "having," are inclusive and therefore specify the presence of stated features, integers, steps, operations, elements, and/or components, but do not preclude the presence or addition of one or more other features, integers, steps, operations, elements, components, and/or groups thereof. The method steps, processes, and operations described herein are not to be construed as necessarily requiring their performance in the particular order discussed or illustrated, unless specifically identified as an order of performance. It is also to be understood that additional or alternative steps may be employed.

**[0031]** When an element or layer is referred to as being "on," "engaged to," "connected to," or "coupled to" another element or layer, it may be directly on,

engaged, connected or coupled to the other element or layer, or intervening elements or layers may be present. In contrast, when an element is referred to as being "directly on," "directly engaged to," "directly connected to," or "directly coupled to" another element or layer, there may be no intervening elements or layers present. Other words used to describe the relationship between elements should be interpreted in a like fashion (e.g., "between" versus "directly between," "adjacent" versus "directly adjacent," etc.). As used herein, the term "and/or" includes any and all combinations of one or more of the associated listed items.

**[0032]** Although the terms first, second, third, etc. may be used herein to describe various elements, components, regions, layers and/or sections, these elements, components, regions, layers and/or sections should not be limited by these terms. These terms may be only used to distinguish one element, component, region, layer or section from another region, layer or section. Terms such as "first," "second," and other numerical terms when used herein do not imply a sequence or order unless clearly indicated by the context. Thus, a first element, component, region, layer or section discussed below could be termed a second element, component, region, layer or section without departing from the teachings of the example embodiments.

**[0033]** Spatially relative terms, such as "inner," "outer," "beneath," "below," "lower," "above," "upper," and the like, may be used herein for ease of description to describe one element or feature's relationship to another element(s) or feature(s) as illustrated in the figures. Spatially relative terms may be intended to encompass different orientations of the device in use or operation in addition

to the orientation depicted in the figures. For example, if the device in the figures is turned over, elements described as "below" or "beneath" other elements or features would then be oriented "above" the other elements or features. Thus, the example term "below" can encompass both an orientation of above and below. The device may be otherwise oriented (rotated 90 degrees or at other orientations) and the spatially relative descriptors used herein interpreted accordingly.

**[0034]** With reference to the Figures, a compressor 10 is shown to include a generally cylindrical hermetic shell 12, a motor 14, a driveshaft 16, a main bearing housing 18, an orbiting scroll member 22, a non-orbiting scroll member 24, a separation baffle 25, and a lubrication system 27.

**[0035]** The hermetic shell 12 includes a welded cap 26 at a top portion 23, and a base 28 having a plurality of feet 29 welded at a bottom portion 31. The cap 26 and the base 28 are fitted to the shell 12 such that an interior volume 30 of the compressor 10 is defined. Lubricant may be stored within the bottom portion 31 of the hermetic shell 12 for lubricating the moving parts of the compressor 10, as will be described below. The cap 26 is provided with a discharge fitting 32 in fluid communication with the interior volume 30 of the compressor 10 and an inlet fitting 34 in fluid communication with the exterior of the compressor 10. An electrical enclosure, such as a plastic cover (not shown), may be attached to the cap 26 and may support a portion of an electrical protection and control system (not shown) therein.

**[0036]** The driveshaft 16 is rotatably driven by the motor 14 relative to the shell 12. The motor 14 includes a stator 40 fixedly supported by the hermetic shell 12, windings 42 passing therethrough, and a rotor 44 press-fit on the driveshaft 16. The motor 14 and associated stator 40, windings 42, and rotor 44 cooperate to drive the driveshaft 16 relative to the shell 12 to compress a fluid.

**[0037]** The driveshaft 16 may include an eccentric pin 46 mounted to, or integrally formed with, a first end 48 thereof. A portion of the driveshaft 16 is supported by a main bearing 50 provided in the main bearing housing 18. The driveshaft 16 may include a central bore 52 formed at a lower end 54 thereof and an eccentric bore 56 extending upwardly from the central bore 52 to an end surface 58 of the eccentric pin 46. An end portion 60 of the central bore 52 may be immersed in the lubricant at the bottom portion 31 of the hermetic shell 12 of the compressor 10 (FIG. 1), such that lubricant can be pumped from the bottom portion 31, and up through the end surface 58 of the eccentric pin 46.

**[0038]** Under the action of the centrifugal force generated by the rotation of the driveshaft 16, the lubricant may traverse the central bore 52 from the end portion 60 to the end surface 58 of the eccentric pin 46. Lubricant exiting the end surface 58 of the eccentric pin 46 may create a lubricant supply area 59 between the eccentric pin 46 and the orbiting scroll member 22 and between the main bearing housing 18 and the orbiting scroll member 22, lubricating the rotational joints and sliding surfaces therebetween. As will be described below, the lubricant supply area 59 may also supply lubricant to the lubrication system 27.

**[0039]** The orbiting scroll member 22 may be disposed within, and axially supported by, the main bearing housing 18. An inner hub 61 of the orbiting scroll member 22 may be rotatably coupled to the eccentric pin 46. Alternatively, the inner hub 61 may be rotatably coupled to the eccentric pin 46 via a bushing or bearing 63. An upper surface 62 of the orbiting scroll member 22 includes a spiral vane or wrap 64 for use in receiving and compressing a fluid received through the inlet fitting 34. An Oldham coupling 66 is disposed generally between the orbiting scroll member 22 and the main bearing housing 18 and is keyed to the orbiting scroll member 22 and the non-orbiting scroll member 24. The Oldham coupling 66 restricts rotational motion between the non-orbiting scroll member 24 and the orbiting scroll member 22. The Oldham coupling 66, and its interaction with the orbiting scroll member 22 and non-orbiting scroll member 24, is preferably of the type disclosed in assignee's commonly owned U.S. Patent No. 5,320,506, the disclosure of which is incorporated herein by reference.

**[0040]** The non-orbiting scroll member 24 also includes a wrap 68 extending from a lower surface 69 thereof, and positioned in meshing engagement with the wrap 64 of the orbiting scroll member 22. As the compressor 10 operates, the wrap 68 of the non-orbiting scroll member 24 and the wrap 64 of the orbiting scroll member 22 define moving, isolated crescent-shaped pockets of fluid. The fluid pockets carry the fluid to be handled from a low-pressure zone 71, in fluid communication with the inlet fitting 34, to a high-pressure zone 73, in fluid communication a centrally disposed discharge passage

70 provided in the non-orbiting scroll member 24. The discharge passage 70 fluidly communicates with the interior volume 30 of the compressor 10, such that compressed fluid exits the shell 12 via the discharge passage 70 and discharge fitting 32. The non-orbiting scroll member 24 is designed to be mounted to the main bearing housing 18 using mechanical fasteners (not shown) such as threaded fasteners, bolts, screws, or a similar fastening device.

**[0041]** With reference to FIGS. 1 through 3, the separation baffle 25 is shown as being coupled to the non-orbiting scroll member 24 and as including a cover portion 72 and a plurality of vertical support members 74. A plurality of channels 76 may extend angularly from the vertical support members 74 to a peak 78 of the cover portion 72. The plurality of channels 76 may cooperate with the vertical support members 74 to facilitate the flow of (i) the compressed fluid from the discharge passage 70 to the discharge fitting 32, and (ii) lubricant from the discharge passage 70 to the bottom portion 31 of the hermetic shell 12. Specifically, as the compressed fluid and lubricant exit the discharge passage 70, they contact a lower surface 80 of the peak 78 of the cover portion 72. From the peak 78, the compressed fluid and lubricant flow down the plurality of channels 76 and contact the vertical support members 74. The compressed fluid is forced to each side of the vertical support members 74, where it flows back to the peak 78 of the cover portion 72, along an upper surface 82 thereof, prior to exiting the compressor 10 through the discharge fitting 32. The lubricant, due to the weight thereof, flows down the vertical support members 74 upon contact, through the interior volume 30 of the compressor 10 and back to the bottom portion 31 of the

hermetic shell 12, where the lubrication cycle (described in more detail below) begins again.

**[0042]** With reference to FIGS. 4 and 5, in a first configuration of the lubrication system 27, a lubricant supply tube 84 may extend from the bottom portion 31 of the hermetic shell 12 to an upper surface 86 of the non-orbiting scroll member 24. The lubricant supply tube 84 may extend through a slot, groove, aperture, or similar passageway traversing each of the main bearing housing 18 and the non-orbiting scroll member 24, in a direction substantially parallel to a rotational axis 92 of the driveshaft. The non-orbiting scroll member 24 may include a bore 94 in fluid communication with the lubrication supply tube 84 and extending from the upper surface 86 through the non-orbiting scroll member 24.

**[0043]** The upper surface 62 of the orbiting scroll member 22 may include a counter bore or recess 96. The recess 96 may intermittently fluidly communicate with the bore 94. Specifically, and with reference to FIG. 4, during operation of the compressor 10, pressure, created by the compressed fluid exiting the discharge passage 70 and filling the interior volume 30 of the compressor 10, forces the lubricant through the lubricant supply tube 84 and the bore 94. As the orbiting scroll member 22 orbits about the rotational axis 92 of the driveshaft 16, the bore 94 will be in intermittent fluid communication with the recess 96, thereby allowing the high-pressure lubricant disposed within the lubricant supply tube 84 and bore 94 to exit the non-orbiting scroll member 24 and enter the recess 96. Prior to the recess 96 communicating with the bore 94,

the lubricant disposed within the lubricant supply tube 84 and bore 94 is prevented from exiting the non-orbiting scroll member 24, as the non-orbiting scroll member 24—in the area of the bore 94—is in contact with the orbiting scroll member 22, thereby sealing the bore 94, as will be described in greater detail below.

**[0044]** The recess 96 can be sized (for example, the diameter, width, depth, or other dimensions) such that a specific and pre-determined amount of lubricant is able to enter the recess 96 during each period of intermittent fluid communication with the bore 94. For example, the recess 96 may have a diameter of between 5mm and 10mm and a depth between 1mm and 10mm, such that the volume of the recess 96 (and therefore the volume of lubricant stored in the recess 96 during periods of intermittent fluid communication with the bore 94) is approximately  $19 \text{ mm}^3$  to  $785 \text{ mm}^3$ .

**[0045]** With reference to FIG. 5, during intermittent periods of non-communication between the bore 94 and the recess 96 (i.e., when the bore 94 is not aligned with the recess 96), the bore 94 will be sealed by the upper surface 62 of the orbiting scroll member 22. In this position, the recess 96—and any lubricant disposed therein—is exposed to the low-pressure zone 71.

**[0046]** In this position, lubricant will exit the recess 96 and enter the low-pressure zone 71, where it will undergo the compression process created by the orbital movement of the wrap 64 relative to the wrap 68, prior to exiting the discharge passage 70 in the high-pressure zone 73. This process will repeat as the compressor 10 operates and the orbiting scroll member 22 orbits relative to

the non-orbiting scroll member 24. In this manner, a specific amount of lubrication is provided between the wraps 64, 68 of the orbiting scroll member 22 and the non-orbiting scroll member 24 to reduce frictional forces, create sealing between the wrap 64 of the orbiting scroll member 22 and the wrap 68 of the non-orbiting scroll member 24, and dissipate any heat that is created by such frictional forces and/or the compression process.

**[0047]** With reference to FIGS. 6 and 7, another lubrication system 27a is provided for use with the compressor 10 and may include a first lubricant passageway 98 and a second lubricant passageway 100 associated with the main bearing housing 18. The lubrication system 27a is generally similar to the lubrication system 27. Accordingly, like reference numerals are used hereinafter and in the drawings to identify like components while like reference numerals followed by a letter extension (i.e., an “a” or a “b”) are used to identify those components that have been modified.

**[0048]** The first lubricant passageway 98 may be a bore having a first end 102 adjacent to the lubricant supply area 59, and a second end 104 in an outer wall 105 of the main bearing housing 18. The second end 104 may be sealed by a plug member 106, or by sealing engagement with an inner wall 108 of the hermetic shell 12. The first lubricant passageway 98 may extend in a radial direction, substantially perpendicular to the rotational axis 92 of the driveshaft 16. The second lubricant passageway 100 may be a bore having a first end 110 disposed adjacent to the first lubricant passageway 98, and a second end 112 terminating at an upper surface 114 of the main bearing housing

18. The second lubricant passageway 100 may extend in a direction substantially parallel to the rotational axis 92 of the driveshaft 16 or in a direction towards the non-orbiting scroll member 24a.

**[0049]** With reference to FIG. 6, the second end 112 of the second lubricant passageway 100 may be in fluid communication with the lubricant supply tube 84a traversing the non-orbiting scroll member 24a via a first bore 116 formed in the non-orbiting scroll member 24a. The lubricant supply tube 84a may intermittently fluidly communicate with the recess 96 (not shown) of the orbiting scroll member 22, similarly as described above with respect to the configuration shown in FIGS. 4 and 5.

**[0050]** With reference to FIG. 7, in an alternative arrangement of the second configuration, a non-orbiting scroll member 24b may include a first bore 116a, a second bore 118, and a third bore 120. The first bore 116a may be disposed adjacent to the second end 112 of the second lubricant passageway 100. The first bore 116a may extend in a direction substantially parallel to the rotational axis 92 of the driveshaft 16. The second bore 118 may extend from the lower surface 69 of the non-orbiting scroll member 24b and may intermittently fluidly communicate with the recess 96, as described above.

**[0051]** The third bore 120 may extend from an outer surface 124 of the non-orbiting scroll member 24b and may be in fluid communication with the first bore 116a and the second bore 118. The third bore 120 may extend in a radial direction, substantially perpendicular to the rotational axis 92 of the driveshaft 16. A first end 122 of the third bore 120 may be sealed by at least one of a plug

member 126 or by sealing engagement with the inner wall 108 of the hermetic shell 12. In the second configuration, lubricant may be supplied by the central bore 52 of the driveshaft 16, thereby eliminating the need for a separate lubricant supply tube extending from the bottom portion 31 of the hermetic shell 12.

**[0052]** In the first and second arrangements of the lubrication system 27a (FIGS. 6 and 7), high-pressure lubricant may enter the first end 102 of the first lubricant passageway 98 from the lubricant supply area 59. The high pressure lubricant may traverse the lubricant passageways of the first and second configurations before filling the recess 96 (not shown) and providing lubrication to the wraps 64, 68, as described above.

**[0053]** With reference to FIG. 8-12, a third configuration of the lubrication system 27c is provided and may include a lubricant passageway 128 and a counter bore or lubricant recess 130 formed in the orbiting scroll member 22c. The lubrication system 27c is generally similar to the lubrication system 27. Accordingly, like reference numerals are used hereinafter and in the drawings to identify like components while like reference numerals followed by a letter extension (i.e., "c") are used to identify those components that have been modified.

**[0054]** The lower surface 69 of the non-orbiting scroll member 24c may include a counter bore or recess 96c. A first end 132 of the lubricant passageway 128 may be in fluid communication with the lubricant supply area 59 while a second end 134 of the lubricant passageway 128 may be in intermittent fluid communication with the recess 96c. As will be described below, the recess

96c may be in intermittent fluid communication with the lubricant recess 130. The recess 96c can be sized (for example, the diameter, width, depth, or other dimensions) such that a specific and pre-determined amount of lubricant is able to enter the recess 96c during each period of intermittent fluid communication with the lubricant passageway 128. For example, the recess 96c may have a diameter of between 5mm and 10mm and a depth between 1mm and 10mm, such that the volume of the recess 96c (and therefore the volume of lubricant stored in the recess 96c during periods of intermittent fluid communication with the lubricant passageway 128) is approximately  $19 \text{ mm}^3$  to  $785 \text{ mm}^3$ .

**[0055]** With reference to FIGS. 10-12, in the third configuration of the lubrication system 27c, high-pressure lubricant may enter the first end 132 of the lubricant passageway 128 from the lubricant supply area 59. The high-pressure lubricant may traverse the lubricant passageway 128 before filling the recess 96c provided in the non-orbiting scroll member 24c (FIGS. 8 and 9), in the manner described above with respect to the recess 96 of the first configuration (FIGS. 4 and 5).

**[0056]** Upon further rotation of the driveshaft 16 (FIG. 11), and orbital movement of the orbiting scroll member 22c, the recess 96c and the high-pressure lubricant disposed therein may be exposed to the low-pressure lubricant recess 130 provided in the orbiting scroll member 22c. The high-pressure lubricant may exit the recess 96c and enter the lubricant recess 130.

**[0057]** Upon further rotation of the driveshaft 16 (FIG. 12), and orbital movement of the orbiting scroll member 22c, the high-pressure lubricant

disposed in the lubricant recess 130 may be exposed to the low-pressure zone 71. The high-pressure lubricant may exit the lubricant recess 130 and enter the low-pressure zone 71 due to the pressure differential therebetween, where the lubricant will undergo the compression process created by the orbital movement of the wrap 64 relative to the wrap 68, and then exit the discharge passage 70 in the high-pressure zone 73. The foregoing process will repeat as the compressor 10 operates and the orbiting scroll member 22c orbits relative to the non-orbiting scroll member 24c. In this manner, a specific amount of lubrication is provided between the wraps 64, 68 of the orbiting scroll member 22c and non-orbiting scroll member 24c to reduce frictional forces and dissipate any heat that is created by such forces.

**[0058]** With reference to FIG. 13 and 14, a fourth configuration of the lubrication system 27d is provided and may include a lubricant passageway 128d and a counter bore or lubricant recess 130d formed in the orbiting scroll member 22d. The lubrication system 27d is generally similar to the lubrication system 27c. Accordingly, like reference numerals are used hereinafter and in the drawings to identify like components while like reference numerals followed by a letter extension (i.e., "d") are used to identify those components that have been modified.

**[0059]** The lower surface 69 of the non-orbiting scroll member 24d may include a counter bore or recess 96d and a groove or channel 136. As illustrated in FIG. 13, the channel 136 may extend arcuately from and between a first end 138 and a second end 140. The first end 138 may be adjacent or proximate the

recess 96d. The second 140 may be adjacent or proximate an outer end 142 of the wrap 68. In an assembled configuration, the second end 140 may be in fluid communication with the low-pressure zone 71.

**[0060]** A first end 132d of the lubricant passageway 128d may be in fluid communication with the lubricant supply area 59 while a second end 134d of the lubricant passageway 128d may be in intermittent fluid communication with the recess 96d. Specifically, high-pressure lubricant may enter the first end 132d of the lubricant passageway 128d from the lubricant supply area 59. The high-pressure lubricant may traverse the lubricant passageway 128d before filling the recess 96d provided in the non-orbiting scroll member 24d, in the manner described above with respect to the recess 96c of the third configuration (FIGS. 8-12).

**[0061]** Upon further rotation of the driveshaft 16, and orbital movement of the orbiting scroll member 22d, the recess 96d and the high-pressure lubricant disposed therein may be exposed to the low-pressure lubricant recess 130d provided in the orbiting scroll member 22d. The high-pressure lubricant may exit the recess 96d and enter the lubricant recess 130d, in the manner described above with respect to the lubricant recess 130 of the third configuration (FIGS. 8-12).

**[0062]** Upon further rotation of the driveshaft 16, and orbital movement of the orbiting scroll member 22d, the high-pressure lubricant disposed in the lubricant recess 130d may be exposed to the channel 136 formed in the non-orbiting scroll member 24d. Specifically, as the orbiting scroll member 22d orbits

about the axis 92, the lubricant recess 130d will align with, and be exposed to, the channel 136. The lubricant may enter the first end 138 of the channel 136, and thereafter traverse the length of the channel 136 between the first and second ends 138, 140. Specifically, the second end 140 of the channel 136 may be intermittently exposed to the low-pressure zone 71 when the orbiting scroll member 22d orbits relative to the non-orbiting scroll member 24d. The high-pressure lubricant may exit the second end 140 of the channel 136 and enter the low-pressure zone 71 due to the pressure differential therebetween, Once the lubricant has entered the low-pressure zone 71, it will undergo the compression process created by the orbital movement of the wrap 64 relative to the wrap 68, and then exit the discharge passage 70 in the high-pressure zone 73, in the manner described above with respect to the third configuration (FIGS. 8-12).

**[0063]** The foregoing process will repeat as the compressor 10 operates and the orbiting scroll member 22d orbits relative to the non-orbiting scroll member 24d. In this manner, a specific amount of lubrication is provided between the wraps 64, 68 of the orbiting scroll member 22d and non-orbiting scroll member 24d to reduce frictional forces and dissipate any heat that is created by such forces.

**[0064]** The foregoing description of the embodiments has been provided for purposes of illustration and description. It is not intended to be exhaustive or to limit the disclosure. Individual elements or features of a particular embodiment are generally not limited to that particular embodiment, but, where applicable, are interchangeable and can be used in a selected

embodiment, even if not specifically shown or described. The same may also be varied in many ways. Such variations are not to be regarded as a departure from the disclosure, and all such modifications are intended to be included within the scope of the disclosure.

## CLAIMS

What is claimed is:

1. A compressor comprising:
  - a shell;
  - a main bearing housing disposed within said shell;
  - a driveshaft supported by said main bearing housing;
  - a non-orbiting scroll member coupled to said main bearing housingand including a first lubricant supply path, said first lubricant supply path in fluid communication with a lubricant source; and
  - an orbiting scroll member rotatably coupled to said driveshaft and meshingly engaged with said non-orbiting scroll member, said orbiting scroll member having a recess formed therein that is moved between a first position in fluid communication with said first lubricant supply path and a second position fluidly isolated from said first lubricant supply path.
2. The compressor of Claim 1, wherein said recess is moved between said first position and said second position based on a relative position of said orbiting scroll member and said non-orbiting scroll member.
3. The compressor of Claim 2, wherein said relative position of said orbiting scroll member and said non-orbiting scroll member is based on rotation of said driveshaft.

4. The compressor of Claim 1, wherein said lubricant source is a lubricant supply region disposed adjacent to said driveshaft, and wherein said compressor includes a second lubricant supply path disposed within said main bearing housing, said second lubricant supply path in fluid communication with said first lubricant supply path and said lubricant supply region.

5. The compressor of Claim 4, wherein said second lubricant supply path includes a first branch extending substantially parallel to a rotational axis of said driveshaft and a second branch extending substantially perpendicular to said first branch and having a first end disposed in a sidewall of said main bearing housing.

6. The compressor of Claim 5, wherein said first end of said second branch is sealingly engaged with an inner surface of said shell.

7. The compressor of Claim 1, wherein said first lubricant supply path includes:

a first branch extending from a first surface of said non-orbiting scroll to a second surface of said non-orbiting scroll; and

a second branch in fluid communication with said first branch, said second branch extending from said first surface of said non-orbiting scroll to said second surface of said non-orbiting scroll.

8. The compressor of Claim 7, further comprising a first lubricant supply tube disposed within said shell, said first lubricant supply tube in fluid communication with said first branch and said second branch.

9. The compressor of Claim 1, wherein said first lubricant supply path includes:

a first branch extending from a first surface of said non-orbiting scroll, said first branch extending substantially parallel to a rotational axis of said driveshaft,

a second branch extending from said first surface of said non-orbiting scroll, said second branch extending substantially parallel to said first branch, and

a third branch having a first end disposed in a sidewall of said non-orbiting scroll member.

10. The compressor of Claim 9, wherein said first end of said third branch is sealingly engaged with an inner surface of said shell.

11. The compressor of Claim 1, wherein said orbiting and non-orbiting scroll members define a plurality of compression pockets, and wherein said recess is operable to fluidly communicate with at least one of said compression pockets.

12. A compressor comprising:

- a shell;
- a main bearing housing disposed within said shell;
- a driveshaft supported by said main bearing housing;
- a non-orbiting scroll member coupled to said main bearing housing

and having a first surface defining a first lubricant recess; and

- an orbiting scroll member rotatably coupled to said driveshaft and meshingly engaged with said non-orbiting scroll member, said orbiting scroll member including a second lubricant recess in fluid communication with a lubricant source and movable between a first position in fluid communication with said first lubricant recess and a second position fluidly isolated from said first lubricant recess.

13. The compressor of Claim 12, wherein said second lubricant recess is moved between said first position and said second position based on a relative position of said orbiting scroll member and said non-orbiting scroll member.

14. The compressor of Claim 13, wherein said relative position of said orbiting scroll member and said non-orbiting scroll member is based on rotation of said driveshaft.

15. The compressor of Claim 12, further comprising a lubricant supply path fluidly coupling said second lubricant recess to said lubricant source.

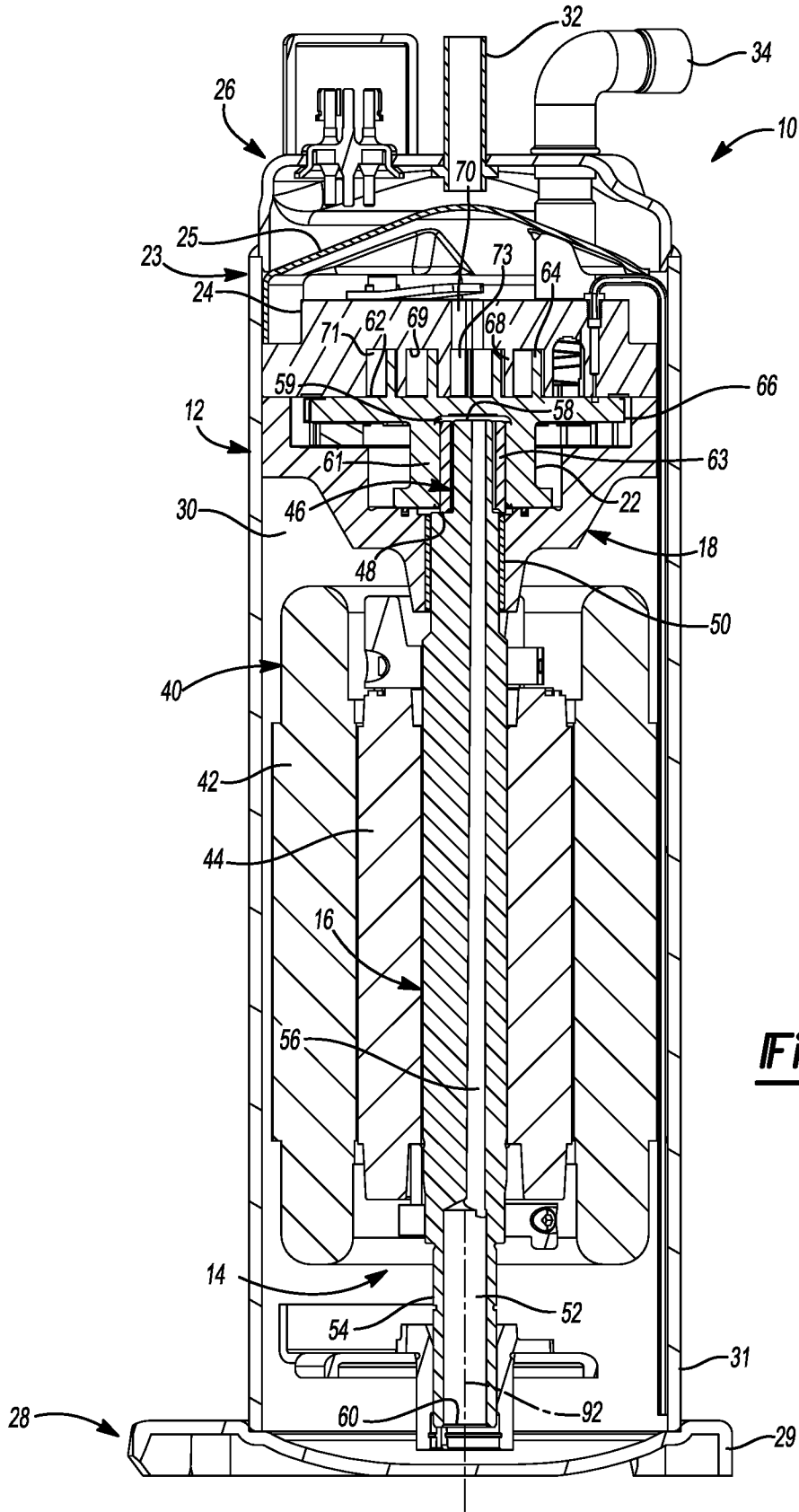
16. The compressor of Claim 15, wherein said lubricant supply path is formed in said orbiting scroll member.

17. The compressor of Claim 15, wherein said lubricant supply path is substantially perpendicular to a longitudinal axis of said driveshaft.

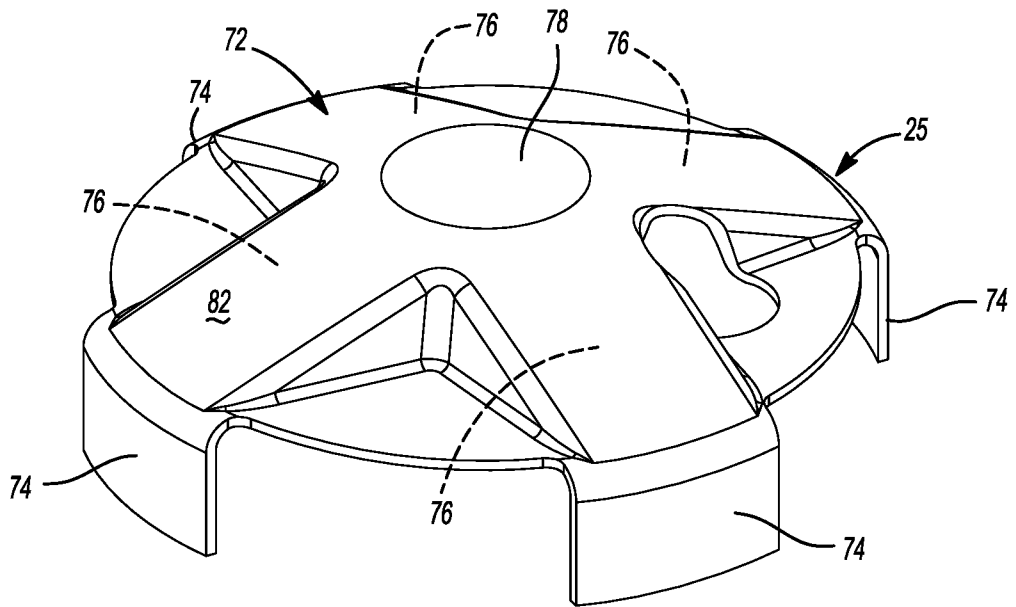
18. The compressor of Claim 12, wherein said second lubricant recess is operable to fluidly communicate with at least one compression pocket formed between said non-orbiting scroll member and said orbiting scroll member.

19. The compressor of Claim 12, wherein said first surface of said non-orbiting scroll member includes a channel operable to selectively place said second lubricant recess in fluid communication with at least one of said compression pockets.

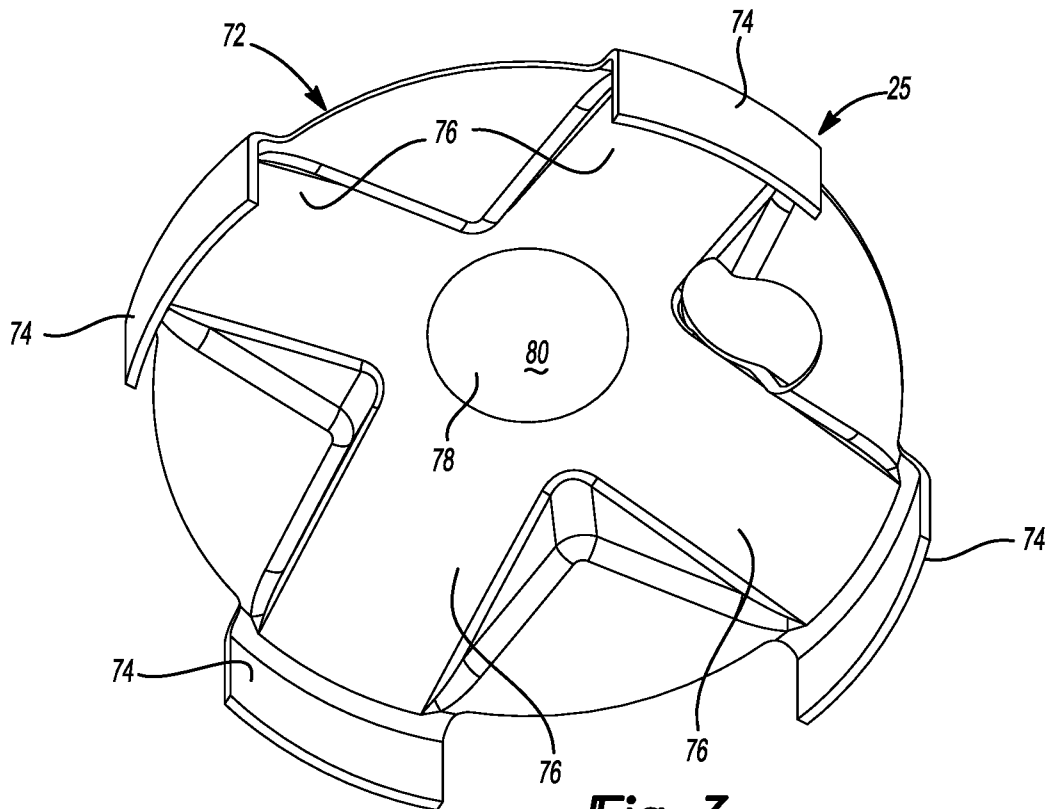
20. The compressor of Claim 19, wherein said channel includes an arcuate shape.



**Fig-1**

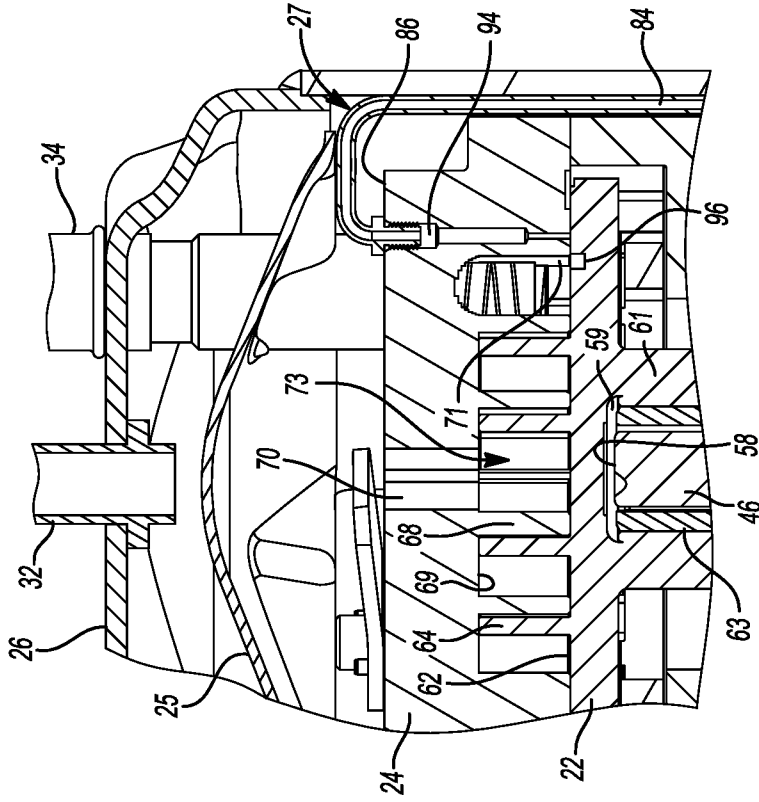


**Fig-2**

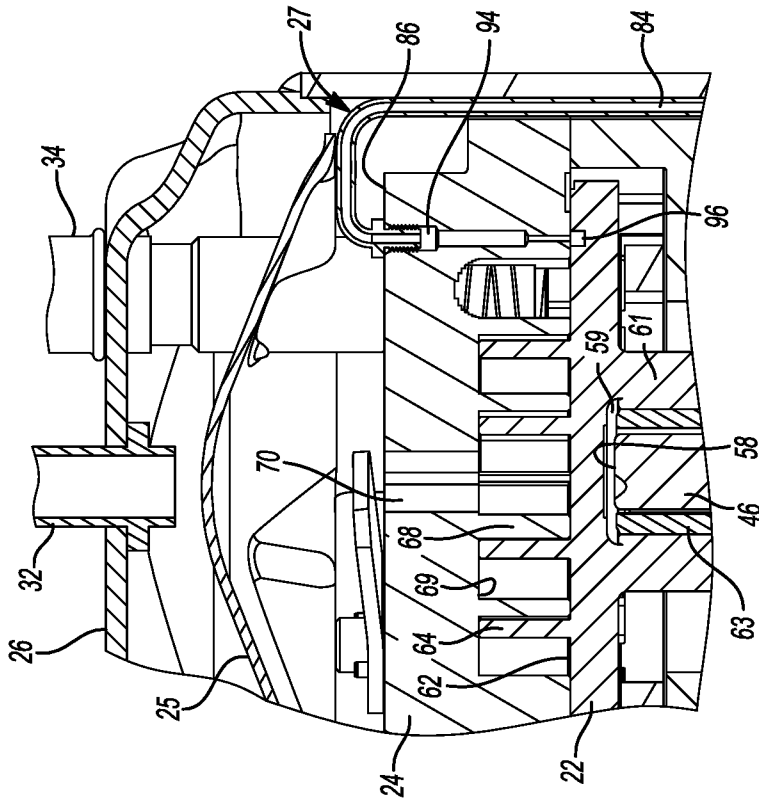


**Fig-3**

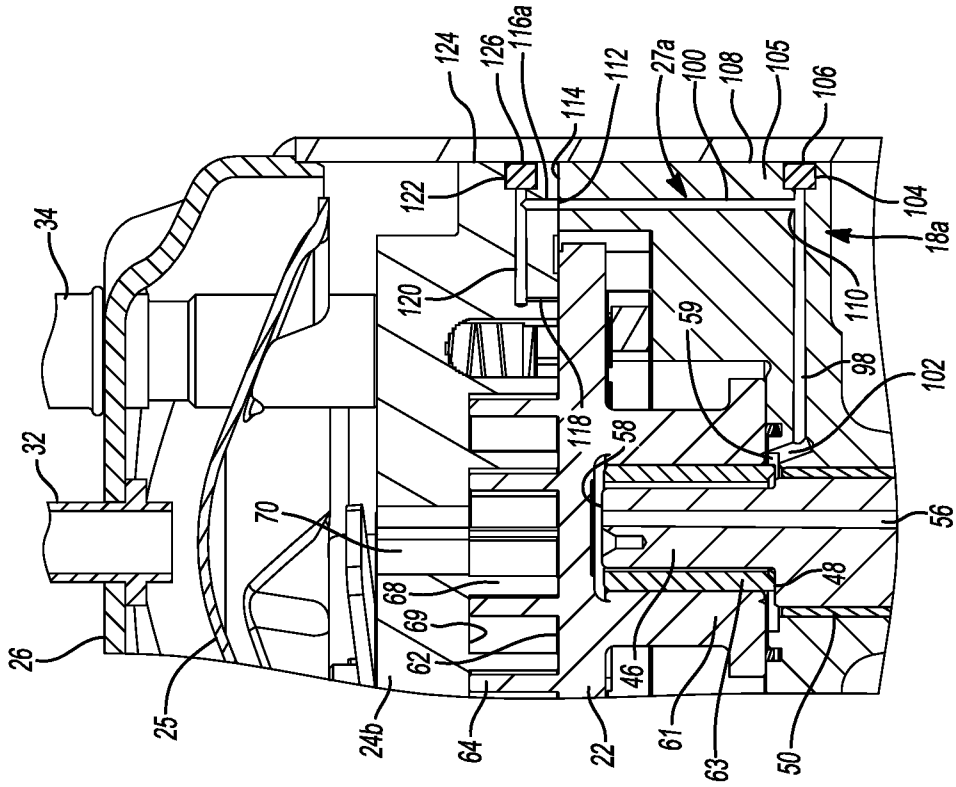




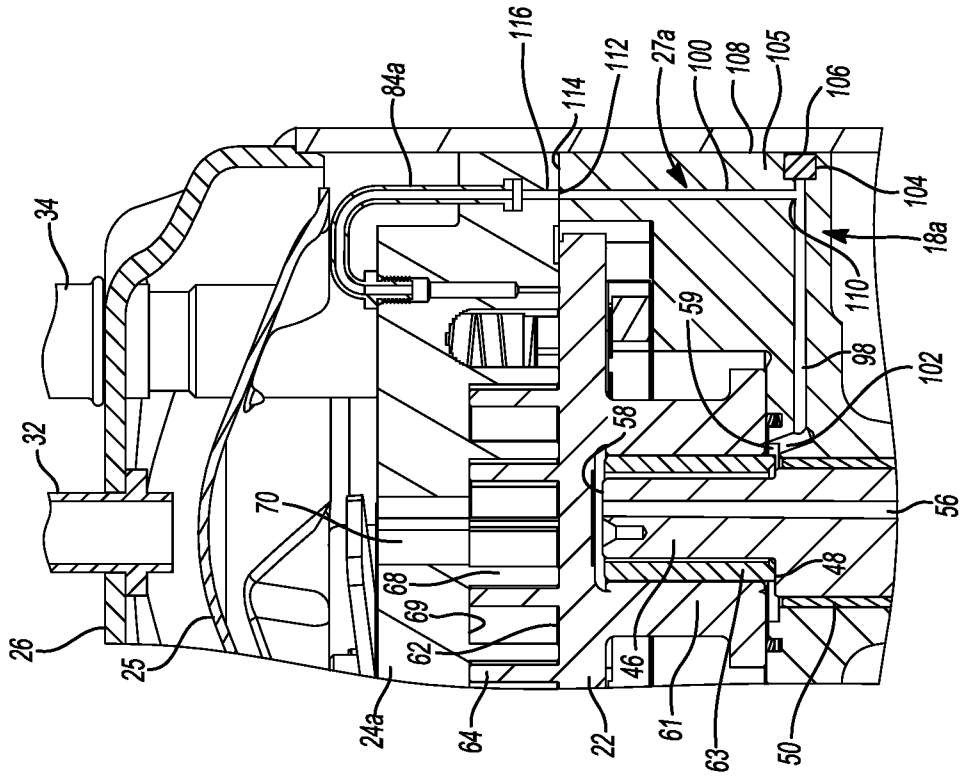
**Fig-5**



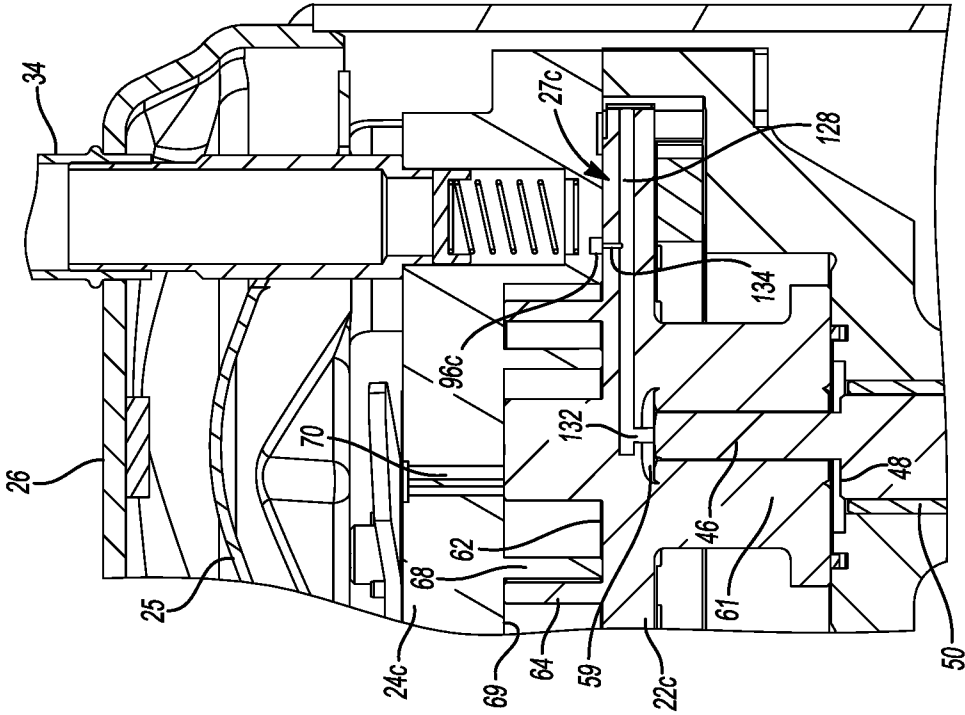
**Fig-4**



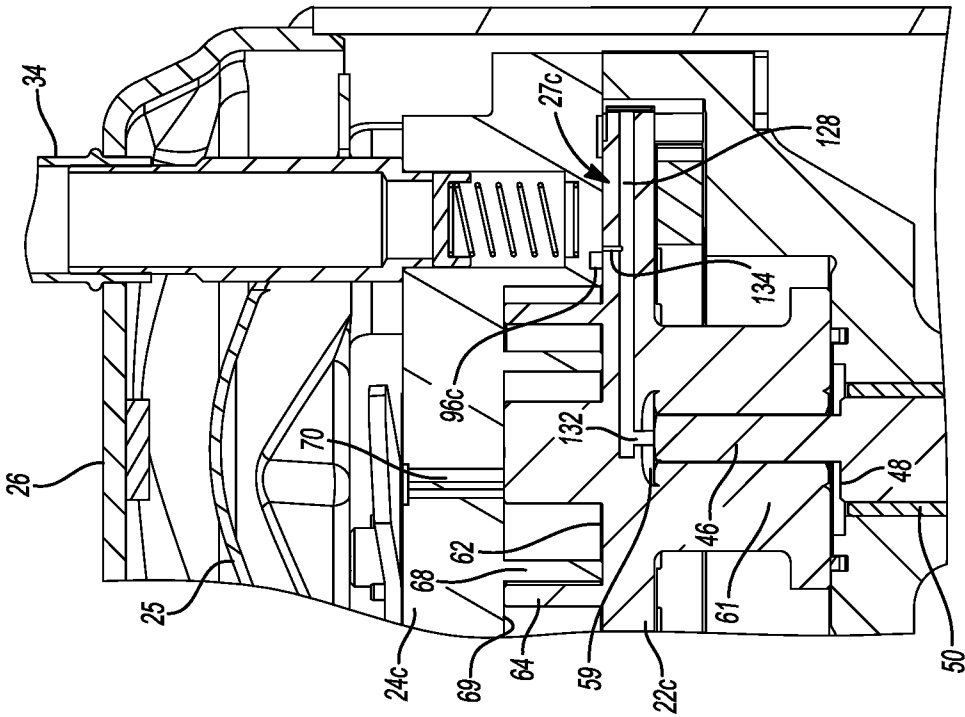
**Fig-7**



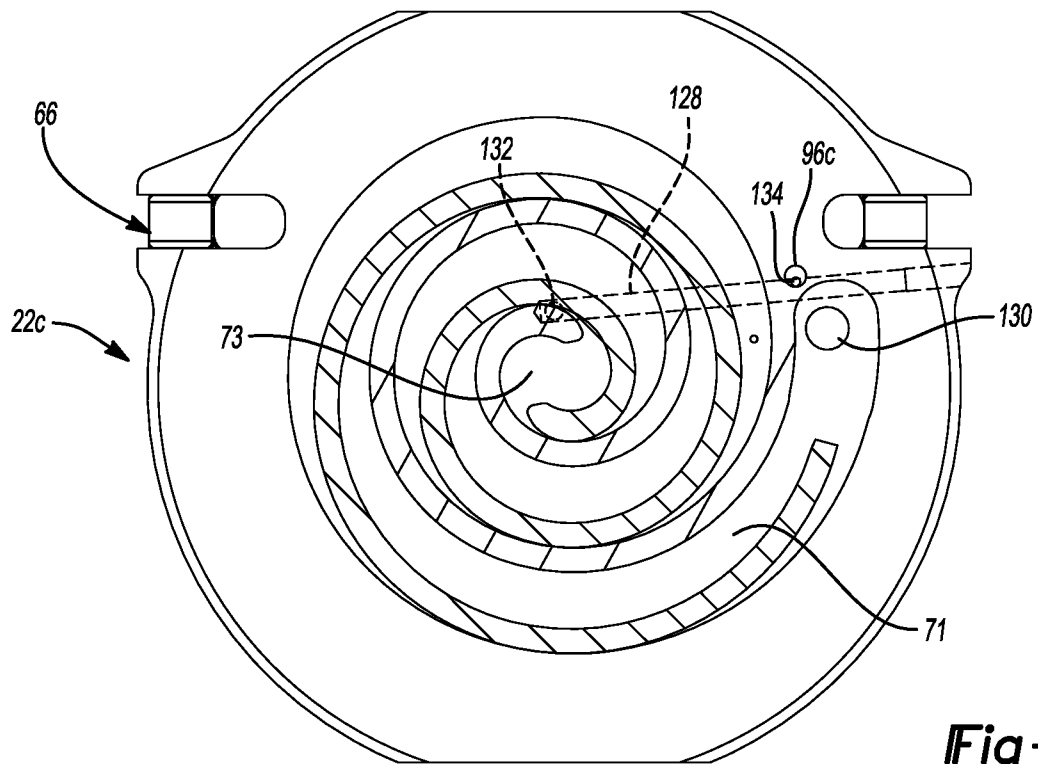
**Fig-6**



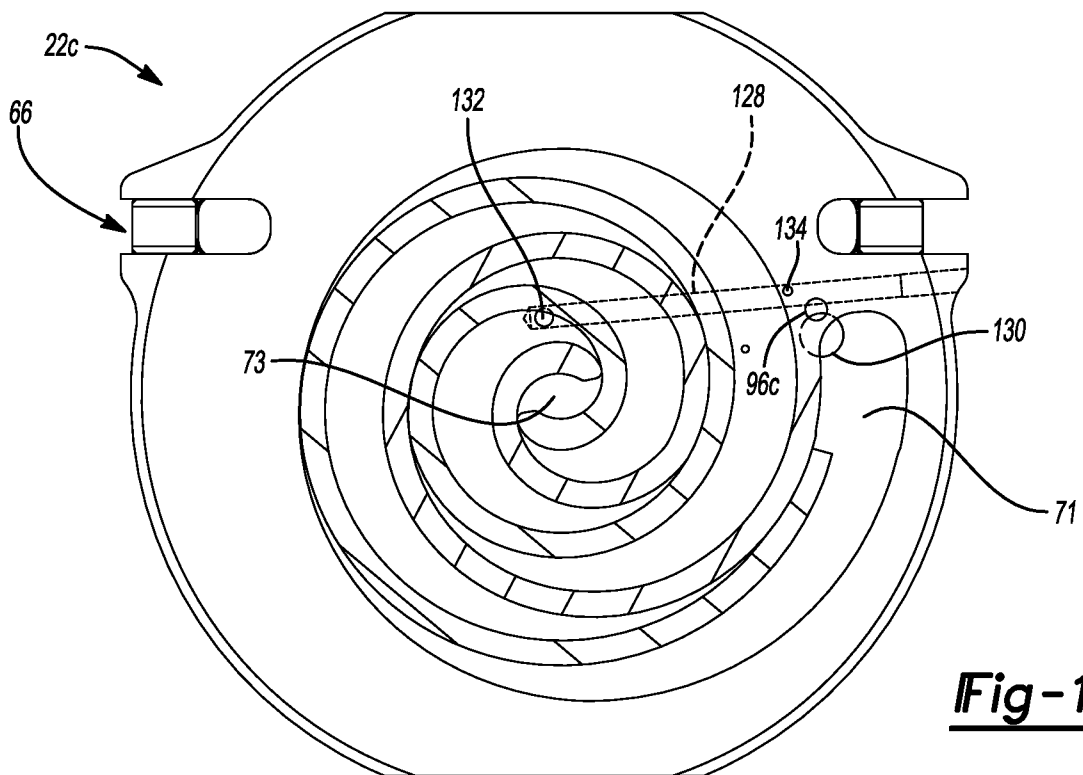
**Fig-9**



**Fig-8**



**Fig-10**



**Fig-11**

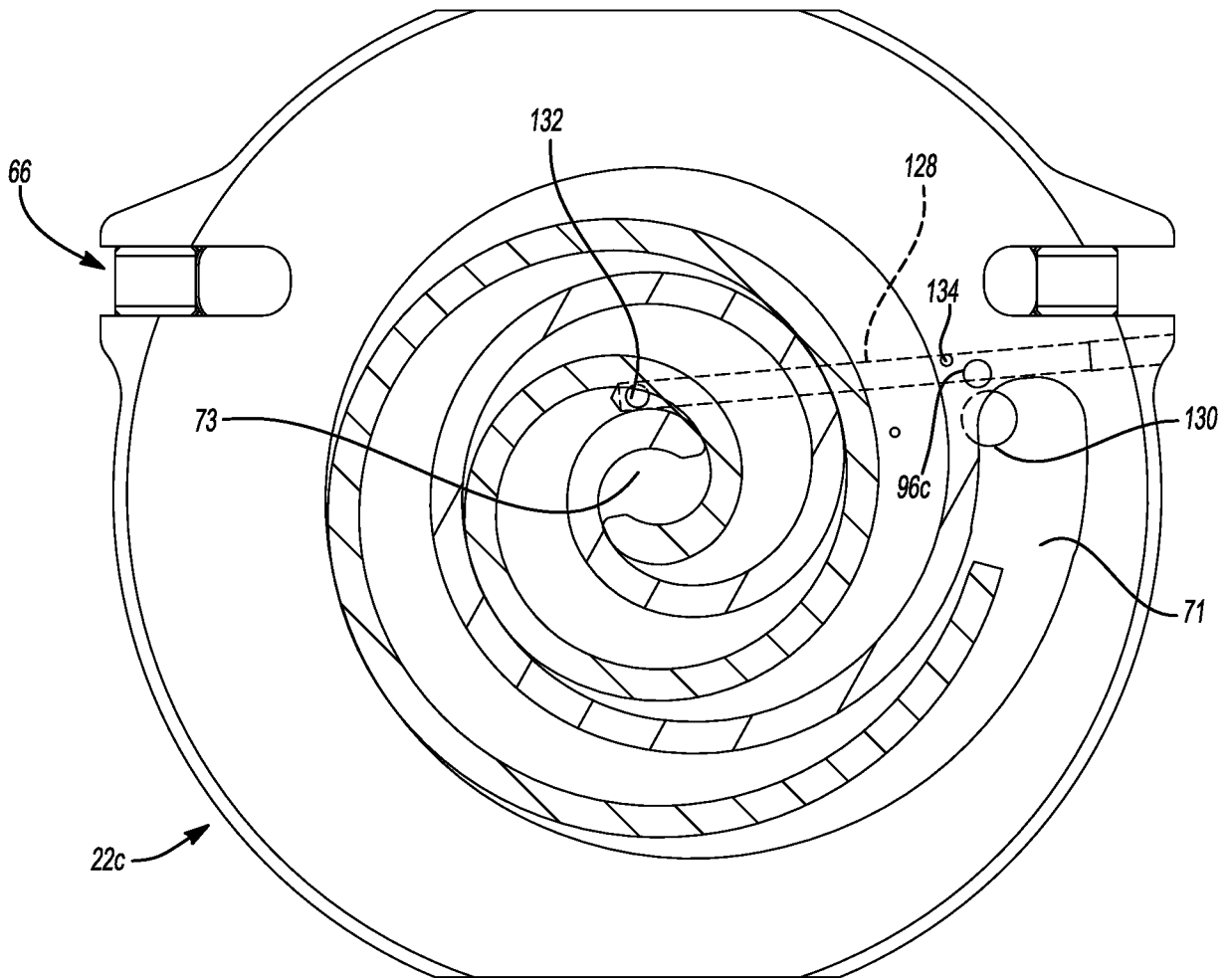
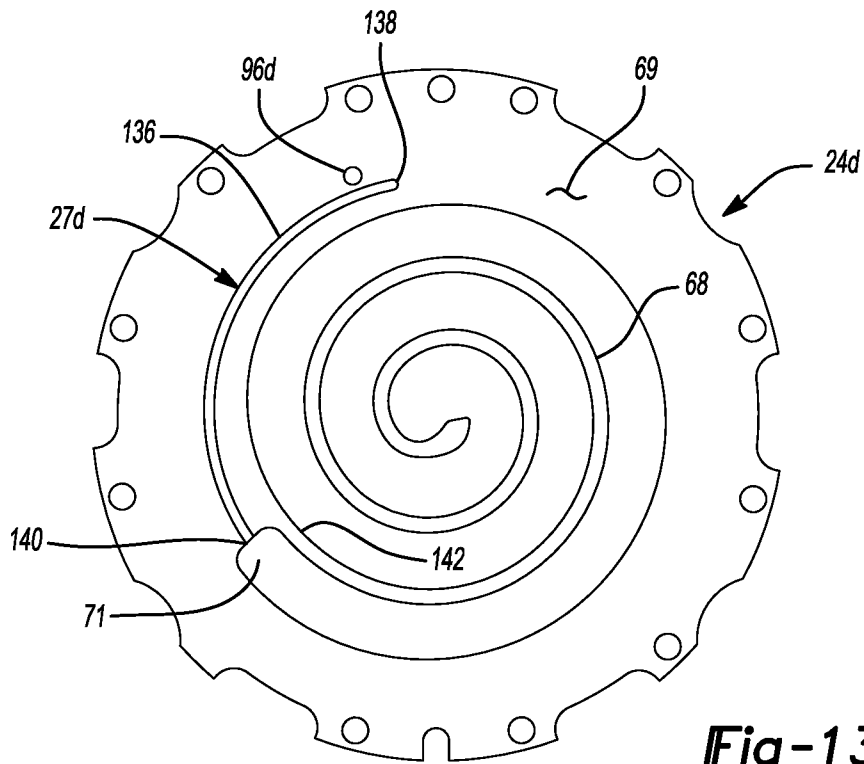
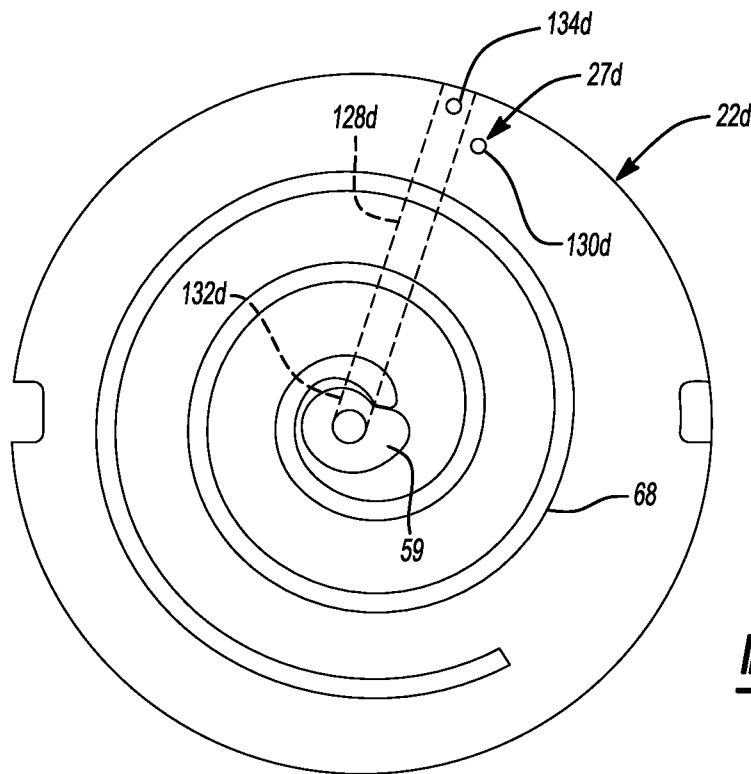


Fig-12



**Fig-13**



**Fig-14**



## INTERNATIONAL SEARCH REPORT

International application No.

PCT/CN2014/080951

<b>A. CLASSIFICATION OF SUBJECT MATTER</b> F04C 29/02(2006.01)i  According to International Patent Classification (IPC) or to both national classification and IPC		
<b>B. FIELDS SEARCHED</b> Minimum documentation searched (classification system followed by classification symbols) F25B1/-; F04C29/-  Documentation searched other than minimum documentation to the extent that such documents are included in the fields searched  Electronic data base consulted during the international search (name of data base and, where practicable, search terms used) CNTXT,CNKI,CNPAT,EPODOC,WPI:suppl+,oil,lurbric+,scroll compressor,intermittent+		
<b>C. DOCUMENTS CONSIDERED TO BE RELEVANT</b>		
Category*	Citation of document, with indication, where appropriate, of the relevant passages	Relevant to claim No.
Y	WO 2012132436 A1 (DAIKIN IND. LTD. ET AL.) 04 October 2012 (2012-10-04) Description, paragraphs [0054]-[0113], figures 1-4	1-20
Y	CN 102454603 A (HITACHI APPLIANCES INC.) 16 May 2012 (2012-05-16) Description, paragraphs [0028]-[0124], figures 1-15	1-20
A	CN 1533480 A (DAIKIN IND. LTD.) 29 September 2004 (2004-09-29) the whole document	1-20
A	CN 202597102 U (DAIKIN IND. LTD.) 12 December 2012 (2012-12-12) the whole document	1-20
A	CN 202250848 U (ANHUI MEIZHI COMPRESSOR CO., LTD.) 30 May 2012 (2012-05-30) the whole document	1-20
A	CN 202250844 U (HUNAN VAQOUNG ELECTRIC CO., LTD.) 30 May 2012 (2012-05-30) the whole document	1-20
<input type="checkbox"/> Further documents are listed in the continuation of Box C. <input checked="" type="checkbox"/> See patent family annex.		
* Special categories of cited documents: "A" document defining the general state of the art which is not considered to be of particular relevance "E" earlier application or patent but published on or after the international filing date "L" document which may throw doubts on priority claim(s) or which is cited to establish the publication date of another citation or other special reason (as specified) "O" document referring to an oral disclosure, use, exhibition or other means "P" document published prior to the international filing date but later than the priority date claimed "T" later document published after the international filing date or priority date and not in conflict with the application but cited to understand the principle or theory underlying the invention "X" document of particular relevance; the claimed invention cannot be considered novel or cannot be considered to involve an inventive step when the document is taken alone "Y" document of particular relevance; the claimed invention cannot be considered to involve an inventive step when the document is combined with one or more other such documents, such combination being obvious to a person skilled in the art "&" document member of the same patent family		
Date of the actual completion of the international search <b>24 July 2014</b>		Date of mailing of the international search report <b>29 September 2014</b>
Name and mailing address of the ISA/ <b>STATE INTELLECTUAL PROPERTY OFFICE OF THE P.R.CHINA(ISA/CN) 6,Xitucheng Rd., Jimen Bridge, Haidian District, Beijing 100088 China</b>		Authorized officer <b>LIU, Yazhu</b>
Facsimile No. (86-10)62019451		Telephone No. (86-10)62413146

**INTERNATIONAL SEARCH REPORT**  
**Information on patent family members**

International application No.

**PCT/CN2014/080951**

Patent document cited in search report			Publication date (day/month/year)	Patent family member(s)			Publication date (day/month/year)
WO	2012132436	A1	04 October 2012	JP	2012215174	A	08 November 2012
				US	2014017108	A1	16 January 2014
				JP	5206891	B2	12 June 2013
				CN	103477078	A	25 December 2013
<hr/>							
CN	102454603	A	16 May 2012	JP	2012092773	A	17 May 2012
				KR	20120044907	A	08 May 2012
<hr/>							
CN	1533480	A	29 September 2004	US	2004247474	A1	09 December 2004
				BR	0305094	B1	21 August 2012
				JP	3731068	B2	05 January 2006
				TW	I221883	B	11 October 2004
				JP	2004011482	A	15 January 2004
				US	7322809	B2	29 January 2008
				BR	0305094	A	21 September 2004
				KR	100538061	B1	20 December 2005
				AU	2003227511	B2	12 May 2005
				CN	1327137	C	18 July 2007
				EP	1510695	A1	02 March 2005
				KR	20040029164	A	03 April 2004
				WO	03104657	A1	18 December 2003
				AU	2003227511	A1	22 December 2003
<hr/>							
CN	202597102	U	12 December 2012			Non	e
<hr/>							
CN	202250848	U	30 May 2012			Non	e
<hr/>							
CN	202250844	U	30 May 2012			Non	e
<hr/>							