



- (51) International Patent Classification:
A47K 11/10 (2006.01) E03C 1/30 (2006.01)
- (21) International Application Number:
PCT/US2013/067732
- (22) International Filing Date:
31 October 2013 (31.10.2013)
- (25) Filing Language: English
- (26) Publication Language: English
- (30) Priority Data:
13/666,130 1 November 2012 (01.11.2012) US
14/068,174 31 October 2013 (31.10.2013) US
- (71) Applicant: MARK INNOVATIONS LLC [US/US];
1301 Casa Del Rey Court, Las Vegas, Nevada 89117 (US).
- (72) Inventors: DRESSEL, Mark C.; 131 Runnymede Avenue, Wayne, Pennsylvania 19087 (US). DRESSEL, Nicole K.; 131 Runnymede Avenue, Wayne, Pennsylvania 19087 (US). MARKU, Gina M.; 1301 Casa Del Rey Court, Las Vegas, Nevada 89117 (US). WEBB, Nicholas J.; 16314 Texas Springs Rd., Redding, California 96001 (US).
- (74) Agents: SIMINSKI, Robert M. et al.; Harness, Dickey & Pierce, P.L.C., P.O. Box 828, Bloomfield Hills, Michigan 48303 (US).
- (81) Designated States (unless otherwise indicated, for every kind of national protection available): AE, AG, AL, AM, AO, AT, AU, AZ, BA, BB, BG, BH, BN, BR, BW, BY, BZ, CA, CH, CL, CN, CO, CR, CU, CZ, DE, DK, DM, DO, DZ, EC, EE, EG, ES, FI, GB, GD, GE, GH, GM, GT, HN, HR, HU, ID, IL, IN, IR, IS, JP, KE, KG, KN, KP, KR,

[Continued on next page]

(54) Title: SANITARY TOILET PLUNGER CONTAINMENT SYSTEM

(57) Abstract: The present invention relates to a toilet plunger containment system including a decorative shell, a selectively removable tray having a disposable disinfectant and a specialized plunger which is housed within the decorative shell during periods of non-use.

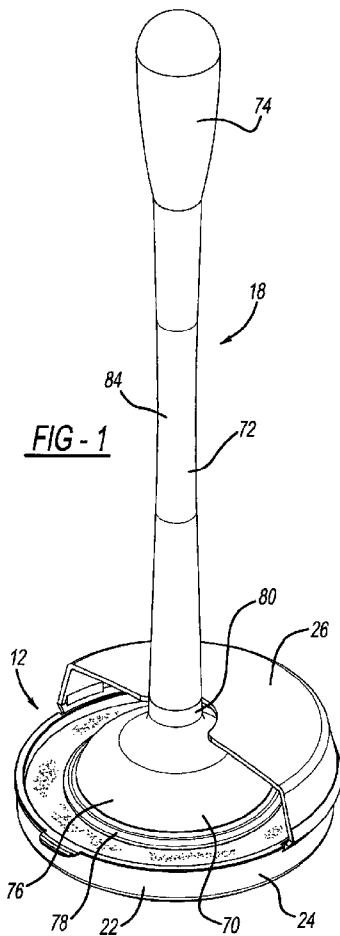

WO 2014/071002 A1

KZ, LA, LC, LK, LR, LS, LT, LU, LY, MA, MD, ME, MG, MK, MN, MW, MX, MY, MZ, NA, NG, NI, NO, NZ, OM, PA, PE, PG, PH, PL, PT, QA, RO, RS, RU, RW, SA, SC, SD, SE, SG, SK, SL, SM, ST, SV, SY, TH, TJ, TM, TN, TR, TT, TZ, UA, UG, US, UZ, VC, VN, ZA, ZM, ZW.

(84) Designated States (unless otherwise indicated, for every kind of regional protection available): ARIPO (BW, GH, GM, KE, LR, LS, MW, MZ, NA, RW, SD, SL, SZ, TZ, UG, ZM, ZW), Eurasian (AM, AZ, BY, KG, KZ, RU, TJ, TM), European (AL, AT, BE, BG, CH, CY, CZ, DE, DK, EE, ES, FI, FR, GB, GR, HR, HU, IE, IS, IT, LT, LU, LV, MC, MK, MT, NL, NO, PL, PT, RO, RS, SE, SI, SK,

SM, TR), OAPI (BF, BJ, CF, CG, CI, CM, GA, GN, GQ, GW, KM, ML, MR, NE, SN, TD, TG).

Declarations under Rule 4.17:

- as to applicant's entitlement to apply for and be granted a patent (Rule 4.17(ii))
- as to the applicant's entitlement to claim the priority of the earlier application (Rule 4.17(iii))

Published:

- with international search report (Art. 21(3))

[0006] In another configuration, a sanitary toilet plunger containment system for holding a plunger during periods of non-use is provided and may include a tray, a disposable disinfecting component, and a housing. The tray may include a first tier and a second tier. The disposable disinfecting
5 component may be positioned within the tray and may be supported by the first tier. The housing may include a circumferential wall which hosts the tray.

[0007] Still other aspects of the invention will be described with reference to the drawings and detailed description provided below.

[0008] Further areas of applicability will become apparent from the
10 description provided herein. The description and specific examples in this summary are intended for purposes of illustration only and are not intended to limit the scope of the present disclosure.

DRAWINGS

[0009] The drawings described herein are for illustrative purposes only
15 of selected embodiments and not all possible implementations, and are not intended to limit the scope of the present disclosure.

[0010] Figure 1 shows a perspective view of the sanitary toilet plunger containment system of the present invention;

[0011] Figure 2 is a top view of the sanitary toilet plunger containment
20 system;

[0012] Figure 3 is a top view of the selectively removable tray of the present invention;

[0013] Figure 4 is a first side view of the sanitary toilet plunger
25 containment system;

[0014] Figure 5 is a front view of the sanitary toilet plunger containment system;

[0015] Figure 6 is a second side view of the sanitary toilet plunger containment system;

[0016] Figure 7 is a rear view of the sanitary toilet plunger containment
30 system;

[0017] Figure 8 is an exploded perspective view of a sanitary toilet plunger containment system according to the present invention;

[0018] Figure 9 is a perspective view of a large sized sanitary toilet plunger containment system;

[0019] Figure 10 is a sectional view taken along line 10-10 of Figure 9 showing a disposable disinfectant component useful according to the teachings
5 of the present invention;

[0020] Figure 11 is an exploded perspective view of an alternative sanitary toilet plunger containment system according to the present invention;

[0021] Figure 11A is a partial sectional view of the sanitary toilet plunger containment system of Figure 11;

10 [0022] Figure 12 is an assembled perspective view of a tray and disinfectant component;

[0023] Figure 12A is a partial sectional view of the assembly of Figure 12;

15 [0024] Figure 13 is a perspective view of an alternative configuration of a tray according to the present invention;

[0025] Figure 13A is a partial sectional view of the tray of Figure 13 including a disinfectant component; and

[0026] Figure 13B is a partial sectional view of the tray and disinfectant component of Figure 13A assembled in a shell.

20 [0027] Corresponding reference numerals indicate corresponding parts throughout the several views of the drawings.

DETAILED DESCRIPTION

[0028] Example embodiments will now be described more fully with
25 reference to the accompanying drawings.

[0029] The shell 12, otherwise referred to herein as a housing, is typically formed from a moldable plastic material and is defined by a body 22 including a base 24 and cover 26 as best shown with reference to Figure 8. The base 24 is in the form of a two tiered bowl wherein the lower tier 28 is defined by
30 a bottom wall 30 and a first circumferential wall 32 and the upper tier 36 extends outwardly and upwardly from the circumferential wall 32. The outwardly projecting portion forms an intervening shelf 40 to assist in retaining the selectively removable tray 14. The upwardly projecting portion forms a second

circumferential wall 44 which is larger than first circumferential wall 32 and includes an upper lip 46 having a plurality of spaced apart flanges 48 designed to engage the upper portion 26 of the shell 12 in a snap fit relationship. Optionally, the shell may include an elongated decorative band 58 which snaps
5 over the junction of the base and cover of the housing when the two components are adjoined.

[0030] The cover 26, which only partially covers the base 24, includes an open area 56 so as to allow for insertion and removal of the toilet plunger, includes a side wall 50 and a semi-circular top wall 52 which serves as a splash
10 guard. The top wall 52 preferably includes a cut-out area 54 sized to receive a lower portion of the toilet plunger handle.

[0031] The selectively removable tray 14, as best shown in Figures 3 and 8, is defined by a body 60 including a bottom wall 62, a side wall 64, and a lip 66 extends outwardly from the side wall. The lip 66 seats over the upper lip
15 46 of the housing. The lip 66 is generally hemispherical and terminates at the edge of upper portion of the housing when the tray is positioned within the shell. Ideally, the body of the tray 14 is sized to fit securely within the body of the housing 12. Extending outwardly from the lip 66 is gripping tab 71 which facilitates insertion and removal of the tray from the housing.

[0032] The tray itself is designed to host a disposable, moisture absorptive material which includes a disinfectant component. This disposable disinfectant can be formed from a variety of moisture absorptive materials including, without limitation, charcoal, cellulosic materials such as wood chips, paper and cardboard or absorbent fibers by way of non-limiting example. The
20 disposable disinfectant should be somewhat hydrophilic and may include disinfectant compositions, deodorizing additives and/or scented materials such as pine or floral scents, among others.

[0033] As should be appreciated, the moisture absorptive material 90 should be capable of being treated with disinfectants and deodorants in liquid, solid or gaseous form, and yet still be sufficiently absorptive after treatment with
30 these types of compositions to consume waste water coming off of the plunger. Preferably, the moisture adaptive material is contained within the tray. A liquid permeable and/or perforated layer 92, is separated from the absorptive material

and is sealed to the edge of the tray as shown in Figure 11A. Alternatively, as shown in Figure 10, the layer 92 can be adjacent to and serves as a wrapping for the absorptive material. By concealing the absorptive material with layer 92, exposure to the disinfecting composition and the absorptive material when loading or emptying the tray can be minimized. Further, pre-packaging the disposable disinfectant facilitates loading and unloading of the composition from the tray as well as ease of storage. As shown in various figures, the packaged absorptive material is ideally sloped to conform to the slope receiving tray.

[0034] Under a highly preferred embodiment, the moisture absorptive material 90 will be in the form of replaceable packets that can be sold separately when refills are needed.

[0035] As for the plunger 18, the major elements include a suction cup 70, the shaft 72 and the handle 74. The cup 70 includes a body 76, a peripheral lip 78 and a coupling portion 80 extending upwardly from the body. The cup is formed from a material such as 60 -90 a durometer silicone, butyl rubber or other liquid injection moldable material or elastomeric thermoplastics which is sufficiently durable and flexible to carry out effective plunging. An added benefit of this type of material is that it has limited porosity and is generally resistant to absorption; that is, toilet matter generally does not stick to it. Under a highly preferred embodiment, the plunger cup will be post treated to substantially eliminate the porosity all together. A high polished diamond lapping process can be employed to eliminate any surface porosity in the plunger head which is molded from a silicone or other low porosity elastomeric or thermoplastic elastomeric material.

[0036] The shaft 72 is formed from a sufficiently rigid material to withstand the force applied to the plunger during use. Example materials include nylon 66, ABS, polypropylene and other thermoplastic materials that include Teflon like functions that prevent or reduce adhesion of toilet debris to the structure shaft 72 includes an elongated stem 84 and a coupling member 86 extending from the lower end of the shaft which mates with the coupling portion 80 of the cup. As shown, this coupling arrangement is in the form of a male and female threaded embodiment, but as should be appreciated by those skilled in the art, various mechanical coupling arrangements could be utilized. Further,

the male and female aspects could be on either the cup or the shaft as long as effective mating is achieved.

[0037] Extending along the upper end 86 of the shaft 72 is an enlarged handle 74. As shown, the upper end has a substantially bulbous shape to enhance the ergonomics of the plunger during use. The handle may also include an end cap 88 which is formed from a material which is particularly useful for ergonomic purposes. Alternatively, the upper end 86 can be over molded with an elastomeric material for comfort.

[0038] Referring particularly to Figure 9, an alternative sanitary toilet plunger containment system is shown. As should be readily apparent, this version is particularly suited for larger, industrial type plungers. As such, the upper portion 26' has a larger height dimension as compared to the embodiment shown in Figures 1-8. In virtually all other aspects, the containment system is the same. The need for a larger upper portion is that the plunger cup 70' itself is larger than industrial type plungers.

[0039] Referring to Figure 11, an alternative sanitary toilet plunger containment system is shown. Under this embodiment, the moisture absorptive material 90 disposed within the tray and is sealed by a moisture permeable layer attached to the tray. The disposable tray is generally formed from a plastic material, preferably from a recycled feedstock. Again, a moisture absorptive material which is either naturally disinfecting or which can be treated with the appropriate disinfectants and deodorizing agents will be employed as previously described. By pre-packaging both the tray, the moisture absorptive material and the moisture permeable layer as an assembly, the construct 94 can be disposed of when necessary and is readily replaceable.

[0040] The packaging (not shown) for the construct would preferably be moisture resistant to preserve the moisture absorbing characteristics of the absorptive material.

[0041] Still another variation of the present invention is shown in Figure 12. According to this embodiment, the moisture absorptive material is in the form of a wafer or disc positioned within a tray. A space 98 occurs below the absorptive material to capture excess waste water coming off of the plunger if

need be. In this embodiment, the disposable disinfectant component is sufficiently rigid to support the plunger when placed thereupon.

[0042] Referring to Figures 13 through 13B, an alternative tray 14A is shown. The tray 14A may be used with any of the sanitary toilet plunger
5 containment systems shown herein, and may be similar to the tray 14, except as otherwise provided herein. Accordingly, like reference numerals will be used to describe similar features. Under this embodiment, the moisture absorptive material 90 is disposed within the tray. Again, a moisture absorptive material which is either naturally disinfecting or which can be treated with the appropriate
10 disinfectants and deodorizing agents will be employed as previously described.

[0043] With particular reference to Figure 13, the tray 14A may be defined by a bottom wall 102, a first circumferential wall 104, a second circumferential wall 106, a third circumferential wall 108, and a lip 66A. The bottom wall 102 may include a first tier 110 and a second tier 112. The first tier
15 110 may be substantially planar and horizontal and may be joined to the second tier by a fourth circumferential wall 114. The fourth circumferential wall 114 may extend at least partially in the axial direction, such that the first tier 110 is an upper tier or shelf, and the second tier 112 is a lower tier. The first tier 110 may form a substantially circular portion of the bottom wall 102 and may be
20 concentrically located relative to the second circumferential wall 106. Accordingly, it will be appreciated that the first tier 110 may serve as an axial support for the moisture absorptive material 90 and/or the suction cup 70 or 70' of the plunger 18.

[0044] The first circumferential wall 104 may extend from the second
25 tier 112 at least partially in the axial direction, such that the fourth circumferential wall 114, the second tier 112, and the first circumferential wall 104 substantially forms an annular channel or trough 116. The channel or trough 116 may serve as a receptacle for excess water or moisture that is not absorbed by the moisture absorptive material 90.

[0045] The second circumferential wall 106 may extend radially from
30 the first circumferential wall 104, such that the second circumferential wall 106 substantially forms an intervening annular shelf to assist in supporting the moisture absorptive material 90. Accordingly, an axial height H1 of the second

circumferential wall 106 may be substantially equal to an axial height H2 of the first tier 110, such that the second circumferential wall 106 and the first tier 110 are substantially coplanar. It will be appreciated that the first tier 110 may assist in supporting a central portion of the moisture absorptive material 90, and the
5 second circumferential wall 106 may assist in supporting a peripheral portion of the moisture absorptive material 90. An intermediate portion of the moisture absorptive material 90 (located between the central portion and the peripheral portion) may be substantially aligned with the trough 116, in an unsupported configuration.

10 **[0046]** The third circumferential wall 108 may extend axially from the second circumferential wall 106. The lip 66A extends from the second circumferential wall 106, and may include a radially extending portion 118 and an axially extending portion 120, such that the lip 66A forms a substantially U-shaped channel that seats over the upper lip 46 of the housing 12. The lip 66A
15 terminates at the edge of the upper portion of the housing 12 when the tray 14A is positioned within the housing 12. Ideally, the body of the tray 14A is sized to fit securely within the body of the housing 12. Extending outwardly from the lip 66A is gripping tab 71 which facilitates insertion and removal of the tray from the housing.

20 **[0047]** The plunger containment systems described herein may be offered commercially as a kit. The kit may include at a minimum, a tray and a moisture absorbing component as described above. The kit may also include a decorative shell and optionally a plunger. Again, once the moisture absorptive component is exhausted, refills could be purchased separately.

25 **[0048]** The foregoing description of the embodiments has been provided for purposes of illustration and description. It is not intended to be exhaustive or to limit the disclosure. Individual elements or features of a particular embodiment are generally not limited to that particular embodiment, but, where applicable, are interchangeable and can be used in a selected
30 embodiment, even if not specifically shown or described. The same may also be varied in many ways. Such variations are not to be regarded as a departure from the disclosure, and all such modifications are intended to be included within the scope of the disclosure.

CLAIMS

What is claimed is:

1. A sanitary toilet plunger containment system for holding a plunger
5 during periods of non-use comprising:
a tray including a first shelf portion and a second shelf portion;
a disposable disinfecting component positioned within the tray and
including a first portion supported by the first shelf portion and second portion
supported by the second shelf portion ; and
10 a housing including a circumferential wall which hosts the tray.
2. The sanitary toilet plunger containment system of claim 1 wherein
the first shelf portion is a central portion of the tray and the second shelf portion
is a peripheral portion of the tray.
15
3. The sanitary toilet plunger containment system of claim 1 wherein
the first shelf portion is substantially coplanar with the second shelf portion.
4. The sanitary toilet plunger containment system of claim 1 wherein
20 the first shelf and the second shelf define an annular trough therebetween.
5. The sanitary toilet plunger containment system of claim 1 wherein
the tray further includes an annular lip.
6. The sanitary toilet plunger containment system of claim 5, wherein
25 the annular lip includes a radially extending portion and an axially extending
portion defining a channel.
7. The sanitary toilet plunger containment system of claim 6, wherein
30 the circumferential wall is received within the channel.
8. A sanitary toilet plunger containment system for holding a plunger
during periods of non-use comprising:

a tray including a first tier and a second tier;
a disposable disinfecting component positioned within the tray and supported by the first tier; and
a housing including a circumferential wall which hosts the tray.

5

9. The sanitary toilet plunger containment system of claim 8, wherein the tray further includes an annular shelf portion substantially surrounding the first tier and the second tier.

10

10. The sanitary toilet plunger containment system of claim 9, wherein the shelf portion is substantially coplanar with the first tier.

15

11. The sanitary toilet plunger containment system of claim 6, wherein the second tier is a substantially annular portion of the tray and the disposable disinfecting component is spaced from the second tier.

20

12. The sanitary toilet plunger containment system of claim 8 wherein the tray further includes an annular lip.

13. The sanitary toilet plunger containment system of claim 12, wherein the annular lip includes a radially extending portion and an axially extending portion defining a channel.

25

14. The sanitary toilet plunger containment system of claim 13, wherein the circumferential wall is received within the channel.

1/7

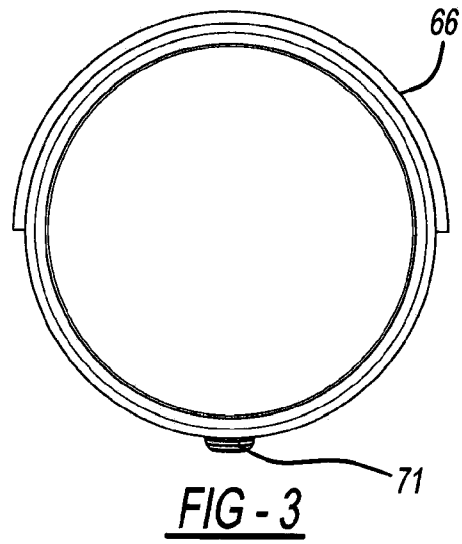
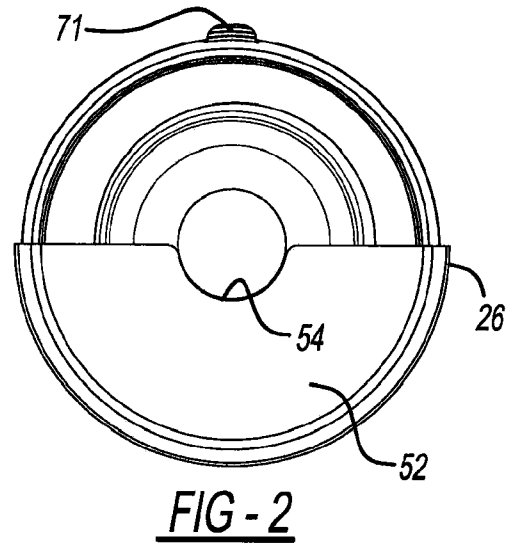
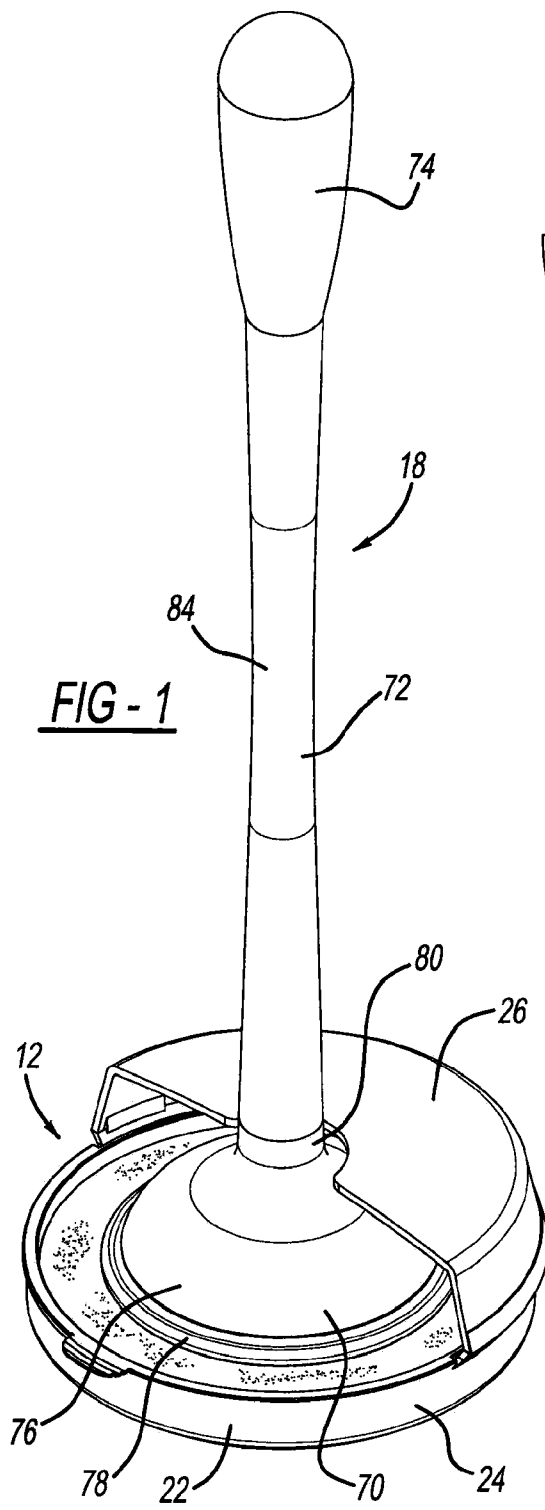

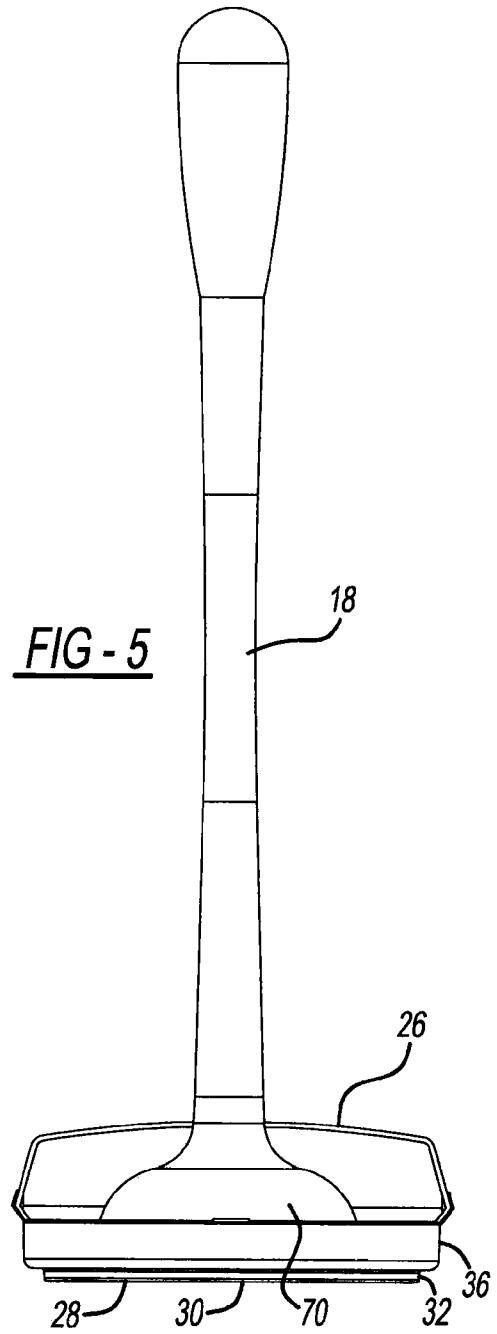
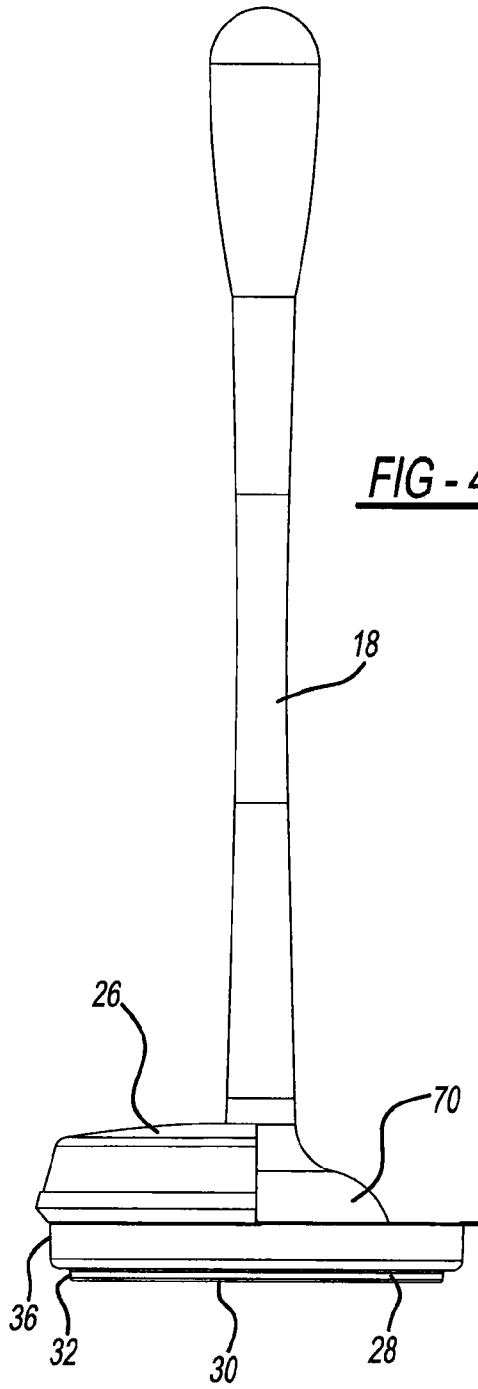

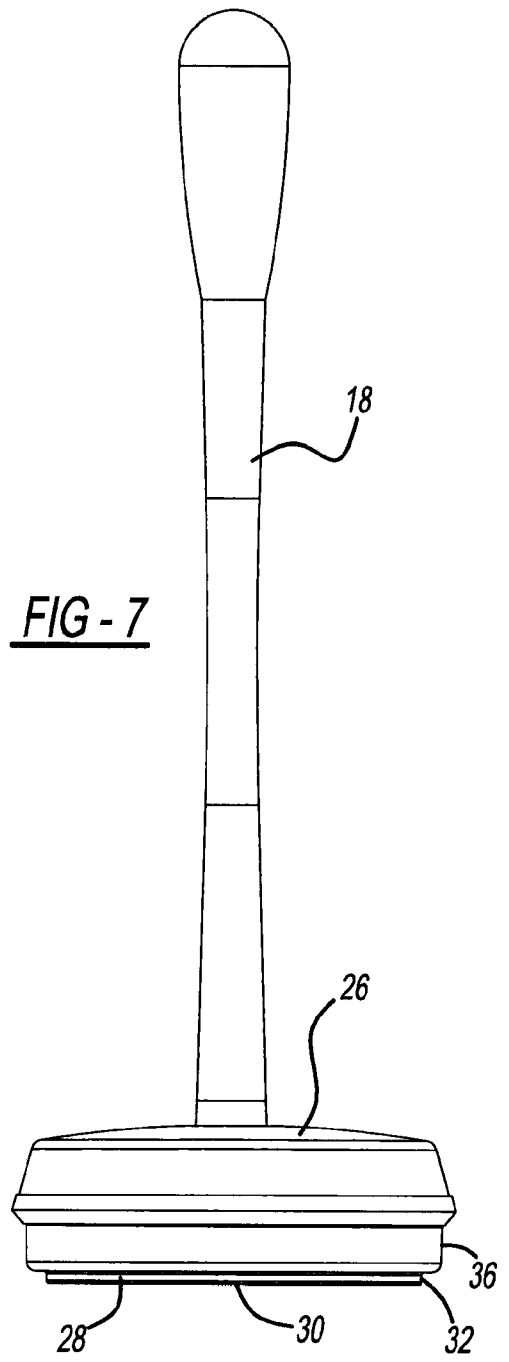
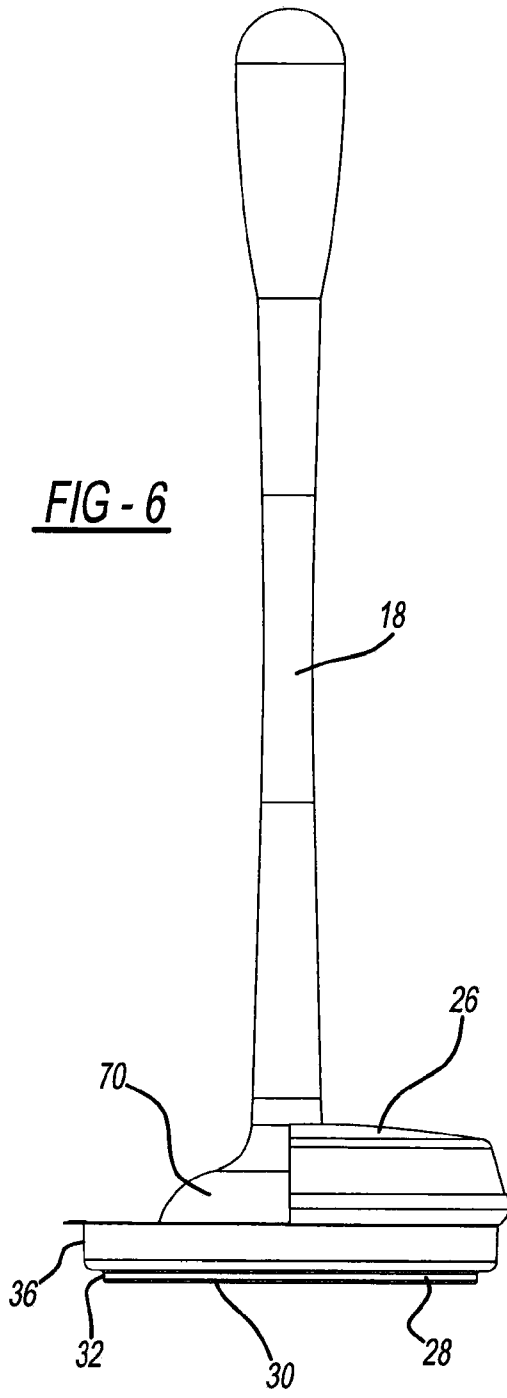

517

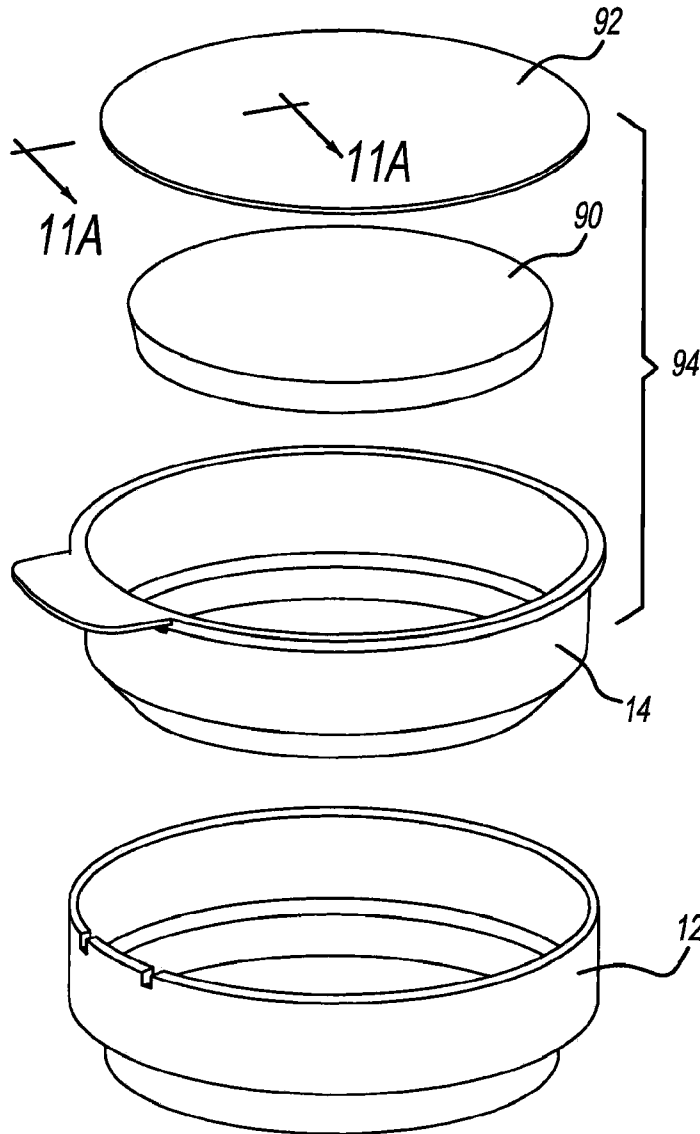

FIG - 11

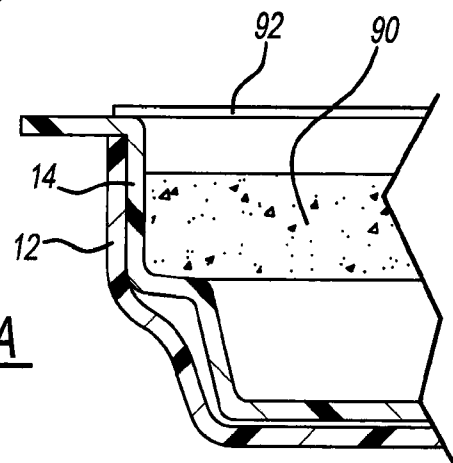

FIG - 11A

6/7

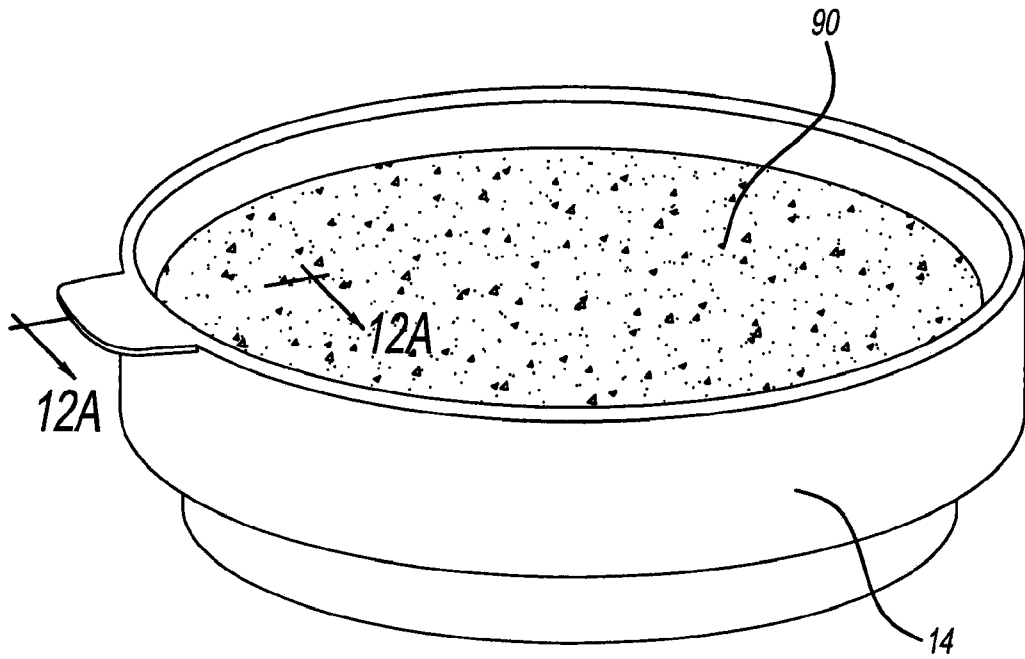

FIG - 12

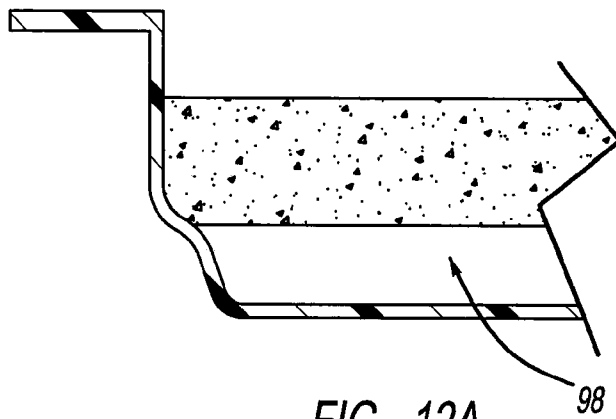

FIG - 12A

717

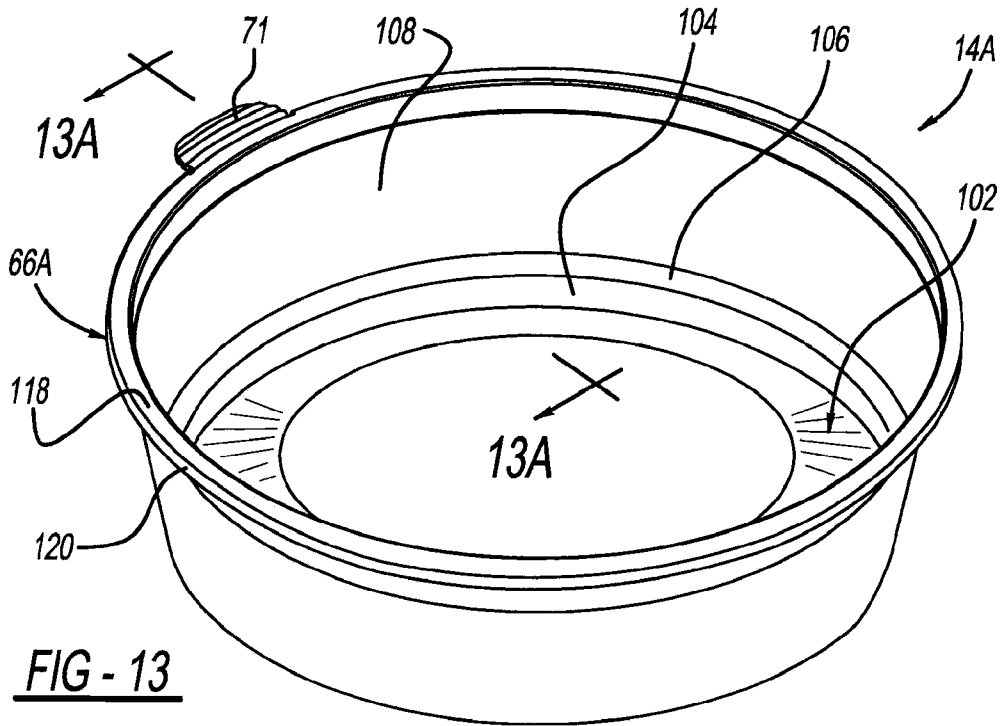

FIG - 13

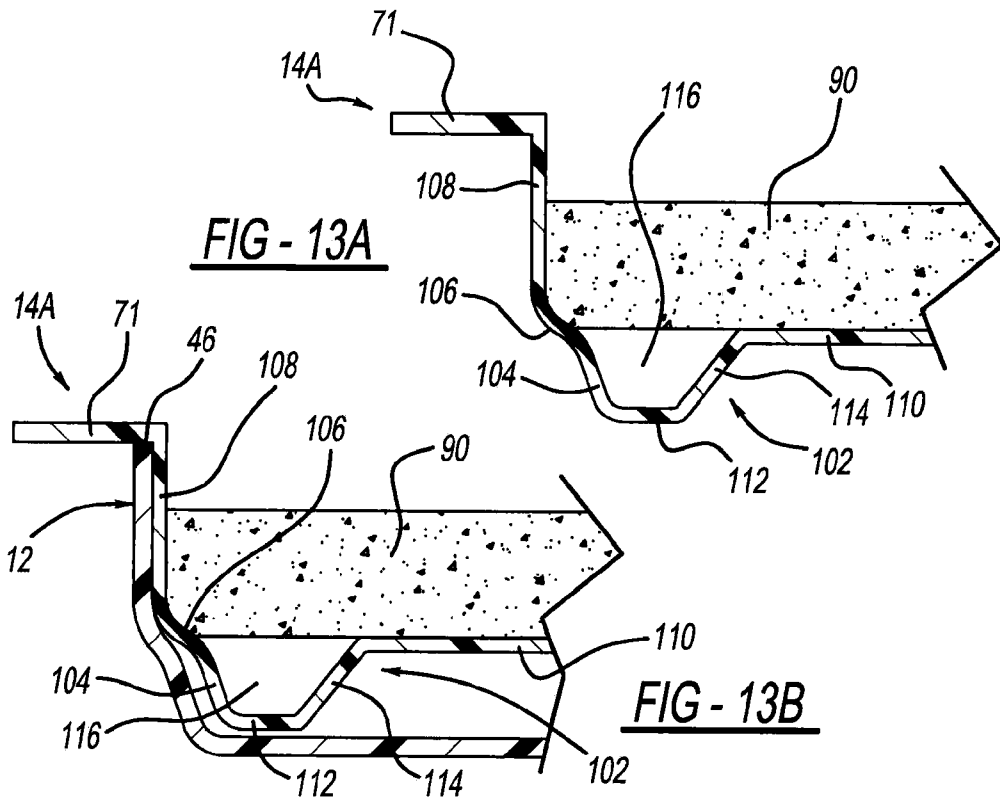

FIG - 13A

FIG - 13B

A. CLASSIFICATION OF SUBJECT MATTER**A47K 11/10(2006.01)i, E03C 1/30(2006.01)i**

According to International Patent Classification (IPC) or to both national classification and IPC

B. FIELDS SEARCHED

Minimum documentation searched (classification system followed by classification symbols)

A47K 11/10; A61L 9/04; B65D 83/00; A61L 2/18; A61L 3/00; A45D 44/00; B65D 69/00; E03C 1/30

Documentation searched other than minimum documentation to the extent that such documents are included in the fields searched

Korean utility models and applications for utility models

Japanese utility models and applications for utility models

Electronic data base consulted during the international search (name of data base and, where practicable, search terms used)

eKOMPASS(KIPO internal) & Keywords: sanitary toilet plunger, containment system, tray, disposable disinfecting component, and circumferential wall

C. DOCUMENTS CONSIDERED TO BE RELEVANT

Category*	Citation of document, with indication, where appropriate, of the relevant passages	Relevant to claim No.
X	US 6383457 B1 (BROWN, MOVIA E.) 07 May 2002 See column 3, lines 3-47 and figures 1-3.	8, 11-14
Y		9-10
A		1-7
Y	US 2009-0211926 A1 (WANG, LONG-SHEH) 27 August 2009 See paragraphs [0023]-[0024],[0026] and figure 5.	9-10
A	WO 2007-033793 A2 (BERGNER, HEIKE) 29 March 2007 See abstract, claim 1, and figures 1-2.	1-14
A	US 4211750 A (CILLESPIE, DORIE) 08 July 1980 See column 2, lines 23-46 and figures 1-2.	1-14
A	US 5984100 A (RAMSEY et al.) 16 November 1999 See column 3, lines 16-29 and figure 2.	1-14

 Further documents are listed in the continuation of Box C. See patent family annex.

* Special categories of cited documents:

"A" document defining the general state of the art which is not considered to be of particular relevance

"E" earlier application or patent but published on or after the international filing date

"L" document which may throw doubts on priority claim(s) or which is cited to establish the publication date of another citation or other special reason (as specified)

"O" document referring to an oral disclosure, use, exhibition or other means

"P" document published prior to the international filing date but later than the priority date claimed

"T" later document published after the international filing date or priority date and not in conflict with the application but cited to understand the principle or theory underlying the invention

"X" document of particular relevance; the claimed invention cannot be considered novel or cannot be considered to involve an inventive step when the document is taken alone

"Y" document of particular relevance; the claimed invention cannot be considered to involve an inventive step when the document is combined with one or more other such documents, such combination being obvious to a person skilled in the art

"&" document member of the same patent family

Date of the actual completion of the international search

14 February 2014 (14.02.2014)

Date of mailing of the international search report

14 February 2014 (14.02.2014)

Name and mailing address of the ISA/KR

Korean Intellectual Property Office
189 Cheongsa-ro, Seo-gu, Daejeon Metropolitan City,
302-701, Republic of Korea

Facsimile No. +82-42-472-7140

Authorized officer

CHOI, Hyun Goo

Telephone No. +82-42-481-8288

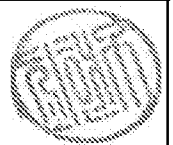

INTERNATIONAL SEARCH REPORT

Information on patent family members

International application No.

PCT/US2013/067732

Patent document cited in search report	Publication date	Patent family member(s)	Publication date
US 6383457 B1	07/05/2002	None	
US 2009-0211926 A1	27/08/2009	US 7861858 B2	04/01/2011
WO 2007-033793 A2	29/03/2007	DE 202005014977 U1 WO 2007-033793 A3	01/02/2007 18/05/2007
US 4211750 A	08/07/1980	None	
US 5984100 A	16/11/1999	None	