

May 9, 1933.

J. A. NOBLE

1,908,531

CAMERA BELLOWS AND METHOD OF MAKING SAME

Filed May 29, 1930

2 Sheets-Sheet 1

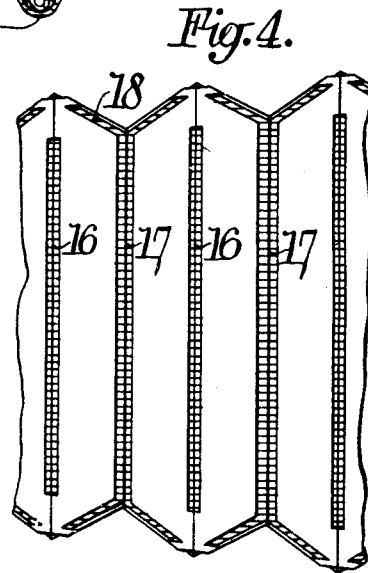
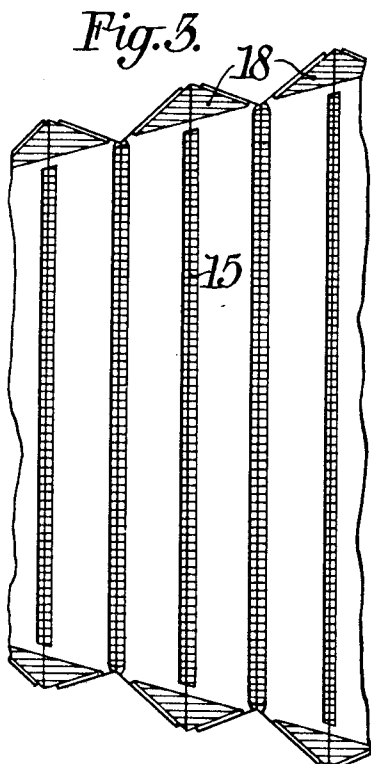
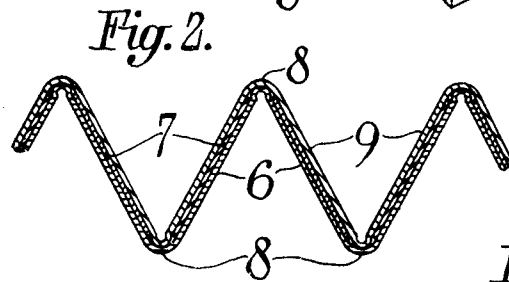
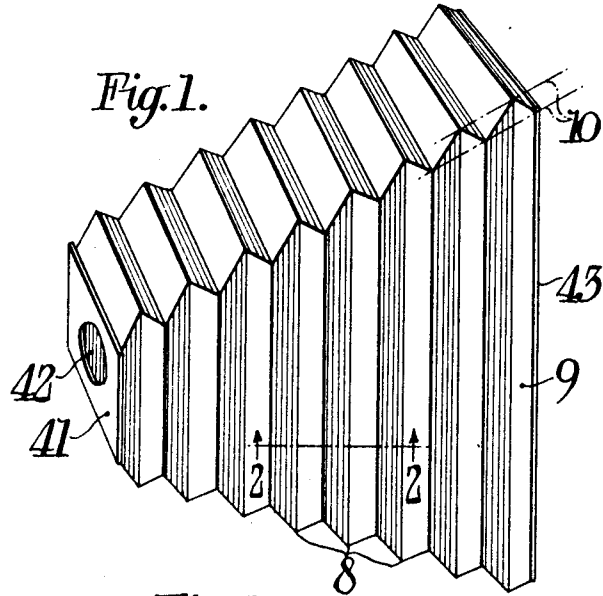

Inventor:

James A. Noble,

By

Newton M. Perrins  
Donald H. Stewart.

Attorneys

May 9, 1933.

J. A. NOBLE

1,908,531

CAMERA BELLOWS AND METHOD OF MAKING SAME

Filed May 29, 1930

2 Sheets-Sheet 2

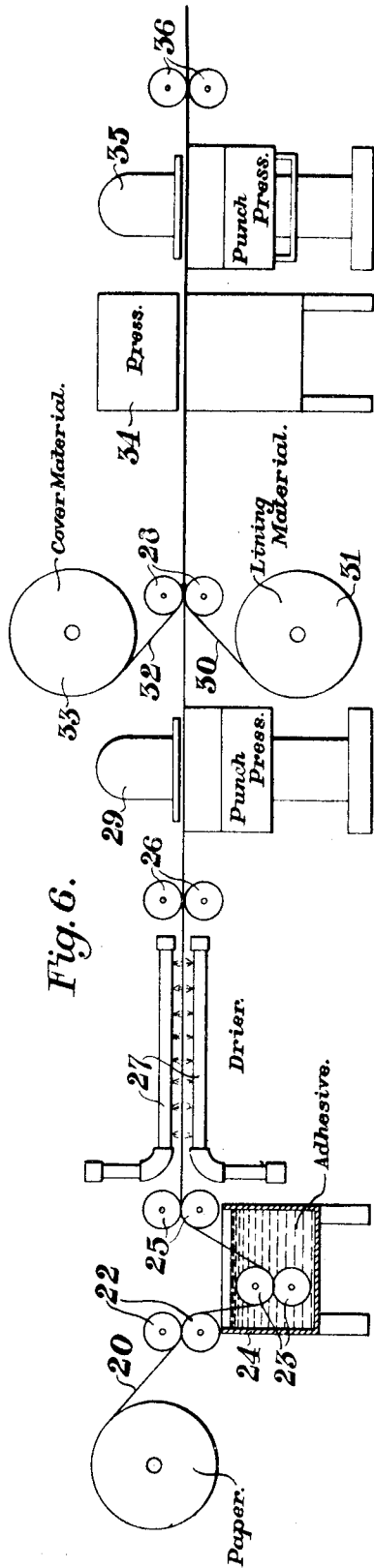
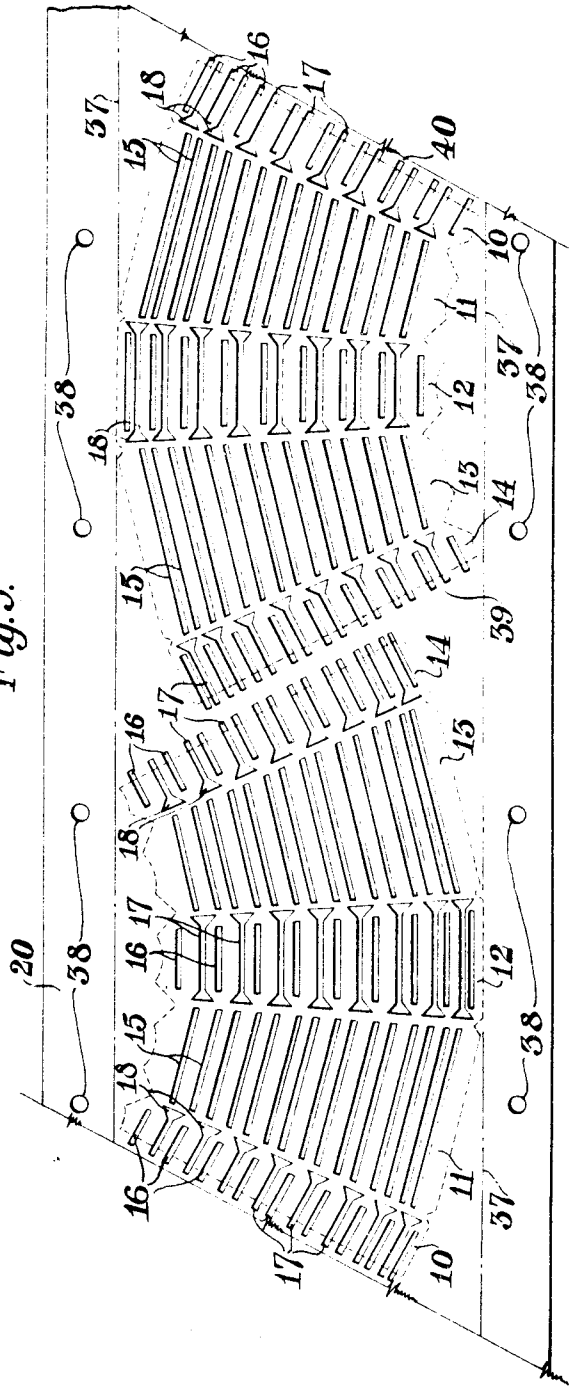

Fig. 6.

Fig. 5.



Inventor,  
James A. Noble,

*Newton W. Smith*  
*Ernest H. Stewart*  
Attorneys

## UNITED STATES PATENT OFFICE

JAMES A. NOBLE, OF ROCHESTER, NEW YORK, ASSIGNOR TO EASTMAN KODAK COMPANY,  
OF ROCHESTER, NEW YORK, A CORPORATION OF NEW YORK

## CAMERA BELLOWS AND METHOD OF MAKING SAME

Application filed May 29, 1930. Serial No. 456,968.

This invention relates to bellows for folding cameras and the method of making the same.

In the past it was customary to make a camera bellows by first manually wrapping the bellows lining tightly on a mandrel having the shape of a truncated pyramid and then fastening two of the edges of this lining together in overlapping relation by means of a suitable adhesive. The outside surface of the bellows lining was then manually moistened, after which a series of individual, parallel, gummed paper strips of a width substantially equal to the distance between adjacent folds of the bellows, when folded, was applied to the outer surface of each of the four sides of the bellows lining. The adhesive was then permitted to dry, after which the outside of the bellows-lining with its spaced paper strips applied thereto was manually covered with a fabric having the appearance of grained leather. The junction between the adjoining edges of this outer covering was formed on the bottom of the bellows the same as the junction of the adjoining edges of inner lining but spaced apart therefrom so that these junction lines would not have the bulky, unsightly appearance which would result if they were formed in superimposed relation. The outer covering was then pressed and adhesively fastened into engagement with the paper strips and the lining, by means of a suitable press engaging the several sides of the mandrel. Since it was necessary for the adhesive of the paper strips to dry before the outer fabric was applied and since there was a tendency for the adhesive to form small lumps on the inner lining, these small lumps when the outer covering was pressed into place frequently pierced the lining and the outer covering thereby causing small pin-hole leaks to develop in the bellows rendering it defective.

In accordance with the present invention a

novel form of bellows and a novel method of making it have been developed in which a continuous strip of paper is covered on both sides with adhesive and then punched into a reticular pattern to which the bellows lining is applied to one side and the covering fabric on the other; then the composite strip thus made is punched out in the form of a blank which when folded gives the desired bellows structure. The edges of this blank, which are to be joined together when the bellows is formed, are then skived and the skived edges are fastened together by a suitable adhesive. All of the operations of applying adhesive to the paper strip, punching the paper strip into a reticular pattern applying the lining material and covering fabric thereto, and subsequently cutting out the blank of composite bellows material, is performed automatically, thereby eliminating many of the manual operations previously necessary. This method obviates the need for mandrels which were expensive to manufacture and which required the services of an expert to keep them in repair. An additional advantage of the present method arises from the fact that, since the adhesive is applied to the paper strip in a uniform layer by machine, there is no tendency for the formation of lumps of adhesive and consequently there is small likelihood of the formation of pin-hole leaks in the finished bellows.

Also in the present arrangement, since the paper strips are all joined together in a reticular blank, the alinement of these strips is assured and an accurate bellows is formed, whereas in the former method, since the individual reinforcing strips were applied to the four outer sides of the bellows in succession, it was difficult to keep all these paper strips in proper alinement, so that when the bellows was finally folded a crooked bellows resulted. Besides this disadvantage, the folds at the corners in the former bellows were not re-

inforced by any paper material and therefore when the camera was in use the bellows would become incorrectly folded, which when repeated, frequently resulted in a cracked bellows. By the use of the present reticular paper support the bellows folds are fixedly defined so that there is very small danger of the bellows being incorrectly closed.

The main features of the invention reside in a bellows as an article of manufacture in which a reticular paper support reinforces not only the sides of the bellows but also portions of the corner folds, together with the novel method of making a bellows. A further feature of the invention relates to a paper blank of reticular pattern suitable for use in reinforcing the bellows of a folding camera.

For a clearer understanding of the invention reference is made to the drawings in which Fig. 1 is a perspective view of an old type of bellows; while Fig. 2 is a cross section thereof taken on the line 2—2 of Fig. 1; Fig. 3 is a side view of a portion of a bellows of the present invention; and Fig. 4 is a top view thereof; Fig. 5 is a plan view of a paper strip showing two sections slitted according to a reticular pattern, ready to be covered with the lining and covering fabric before being formed into blanks for two bellows supports; and Fig. 6 is a diagrammatic showing of the novel method employed in forming the bellows material.

One form of widely used folding camera bellows, shown in Fig. 1, comprises a collapsible structure having the general contour of a truncated pyramid, the lining of which bellows, as shown in Fig. 2, is formed of a light-proof fabric 6 having fastened on its outer surface by suitable adhesive, individual reinforcing strips of paper such as 7 which are spaced apart so that the bellows may collapse by folding on the lines 8. The lining 6 with the attached strips of paper is covered with suitable fabric 9. It is indicated in Fig. 1 by dotted lines that the strips 7 of one side of the bellows are spaced at the corners from the corresponding strips of adjacent sides, being spaced apart a distance equal to the distance between the dotted lines 10. Since the paper strips extend only on the sides of the bellows, there is no support or guide for the triangular shaped folds at the corners of the bellows and consequently the camera may be incorrectly folded unless care is observed.

In the camera bellows of the present invention, however, substantially all parts of the bellows except at the folds are reinforced by an integral support of paper material slit or punched into a blank of reticular pattern as shown in Fig. 5 wherein two such supports are represented.

As indicated in this figure each blank is in the form of the developed surfaces of the sides of a truncated pyramid having a rec-

tangular base, in which the trapezoidal areas 11 and 12 form the side supports of the bellows, while the trapezoidal section 12 forms the top and the trapezoidal sections 10 and 14 when the edges are fastened together form the support for the bottom of the bellows. The side sections 11 and 13 have a series of parallel cutout portions or slits 15 arranged parallel to the longest free edge of the section, and the top section 12 likewise has a series of cutout portions or slits 16 and 17 arranged parallel to the longest free edge thereof and pointing to corresponding slits 15 in the sections 11 and 13. The alternate slits 17 of this section terminate at each end in a triangular cutout portion 18 which portion is represented in the finished bellows support in Fig. 3 while its connection to the slits 17 is indicated in Fig. 4. In this last named figure each end of the slits 17 appears to terminate in a Y-shaped portion but this is due to the fact that part of the triangular portion 18 is folded into the plane of the side of the support. The two sections 10 and 14, serving as the bottom of the finished bellows support likewise, have cutout portions or slits 16 and 17 open at their ends, which slits are so arranged that when the blank is folded into pyramidal form the ends of corresponding slits of these sections are in registry, thereby forming slits in the top and bottom sections which are then substantially identical. It will be noted that, with the exception of the end slits in the top and bottom sections, the other slits of all the sections point to each other and are so arranged that they define a series of rectangular folds when the bellows support is folded.

The above-described bellows particularly lends itself to a novel method of preparing camera bellows which is diagrammatically indicated in Fig. 6 wherein a continuous strip of paper 20 suitable for forming the bellows support is drawn by the pairs of feed rolls 22 and 23 through a tank 24 containing latex or other suitable adhesive material. The rolls 25 apply a uniform layer of latex to both sides of the strip of paper 20, while it is being drawn by two pairs of rolls 25 and 26 between the pipes of a drier 27 having jets for blowing heated air onto the surface of the paper. From the rolls 26 the paper is drawn by another pair of rolls 28 into a punch press generally designated 29 which is equipped with punches and dies arranged to punch two slitted patterns similar to that represented in Fig. 5, each corresponding to the developed surfaces of a bellows blank. Before passing between the rollers 28 the slitted paper strip is joined by the lining fabric 30 for the interior of the bellows, unwound from roller 31, and by the covering material 32 for the exterior of the bellows, unwound from the reel 33. The lining 30 and the covering material 32 cover only the portion of the paper

between the lines 37 which leaves an uncovered margin on each side of the strip of paper in which there are provided perforations to center the strip when the blank is finally cut to size. Then the paper 20 together with the lining material 30 and the covering material 32, passes between the pair of rolls 28 to a press 34 which forces the lining and covering material into adhesive engagement with the surface of the punched strip which has been previously coated with adhesive. The composite strip is now drawn by the pair of rolls 36 into a second punch press which cuts out the two composite bellows blanks along the dotted lines indicated in Fig. 5. It should be stated that the punch presses 29 and 30 and the press 34 are suitably interconnected so that they all operate at the same time. The blank bellows, when thus formed, has its edges 39 and 40 skived by means not shown after which it is folded about a support having the form of a truncated pyramid, whereupon the skived edges 39 and 40 are glued together in overlapping relation. The irregular tabs at the small end of the bellows are then glued to a rectangular plate 41 provided with an aperture 42, while the large end of the bellows is fastened to a rectangular frame 43. Thereafter the bellows is then folded along the slits to provide a series of rectangular folds thereby effecting accordian pleating in the bellows.

What I claim is:

1. A bellows support for a folding camera made in the form of a truncated pyramid open at its ends and having a rectangular base, all of the sides of the support having a plurality of slits correspondingly spaced to serve as guides when the support is folded, alternate slits on two opposing sides of said support having enlarged triangular ends serving as guides for the corner folds of said support when folded.

2. A blank for a bellows support formed from a single piece of material having the shape of the developed surfaces of a truncated pyramid open at its ends and having a series of slits in said surfaces arranged to define a series of rectangular folds when the blank is formed into a support.

3. A blank for a camera bellows support formed from an integral sheet of material having a plurality of trapezoidal areas joined together in accordance with the developed surfaces of a truncated pyramid having a rectangular base, each of said areas having a series of parallel slits or cutout portions, corresponding slits of all the areas being similarly spaced and arranged so that they may define a plurality of rectangular folds in said blank when formed into a bellows support.

4. A blank for a bellow support of a folding camera formed from a single sheet of paper shaped in the form of the developed

surfaces of a truncated pyramid open at its ends and having a rectangular base, said blank comprising two trapezoidal areas identical in shape joined together by a narrower trapezoidal area, each of said three trapezoidal areas having a plurality of parallel slits parallel to its base and similarly spaced with respect to the slits of the other areas, each of said larger trapezoidal areas having attached at one side thereof a trapezoidal area provided with a plurality of open ended slits spaced at an equal distance apart with respect to the slits of the other areas.

5. The method of forming a camera bellows which comprises slitting a paper sheet in several segregated areas, covering said paper with flexible light-proof material, joining two of the edges of said sheet to form a truncated pyramid open at its ends, and forming a series of folds on said slits along the sides of said pyramid.

6. The method of forming a camera bellows which comprises applying adhesive to both sides of a sheet of paper, punching several series of parallel slits in said paper, applying light-proof textile material on each side of said paper, cutting the paper thus covered with textile material to proper size, forming it into a truncated pyramid open at its ends and having a rectangular cross section, and folding said pyramid along said slits.

7. The method of forming a camera bellows which comprises applying latex to both sides of a continuous strip of paper, punching several series of parallel slits in said paper, applying light-proof textile material on each side of said slitted paper, cutting the paper thus covered with textile material into a blank of proper size, forming said blank into a truncated pyramid having a rectangular base, and folding said pyramid along said slits.

8. The method of forming a camera bellows which comprises applying adhesive to both sides of a strip of paper, punching several series of parallel slits in said paper, the slits of one series being oblique to the slits of another series, applying light-proof textile material on each side of said paper, cutting the paper thus covered with textile material into a blank of proper size, forming said blank into a truncated pyramid open at its ends and having a rectangular cross section, and forming folds in said bellows along said slits.

9. The method of forming a camera bellows which comprises applying adhesive to both sides of a sheet of paper, punching a series of parallel slits in said paper in areas having the general outline of a trapezoid, applying light-proof textile material on each side of said paper, cutting the paper thus covered with textile material to size, forming it into a truncated pyramid open at its

ends and having a rectangular cross section, and folding said bellows along said slits.

10. The method of forming a camera bellows which comprises applying adhesive to both sides of a continuous sheet of paper, drying the applied adhesive, punching three series of parallel slits in said paper, the slits of each series being oblique to those of the other series and being defined by an uncut paper margin having the general outline of a trapezoid, punching two other series of parallel slits situated at each side of said strip of paper and having open ends when cut into a blank, applying light-proof textile material on each side of said paper, cutting the paper thus covered with textile material into a blank of the proper size, forming the blank into a truncated pyramid of rectangular cross section with the open ends of said slits in registry and folding said pyramid along said slits.

11. The method of forming a camera bellows which comprises applying adhesive to both sides of a sheet of paper, punching several series of parallel slits in said paper, the slits of the several series being oblique to those of the other series, alternate slits of two series having enlarged triangular ends, then covering both sides of said paper with light-proof textile material, cutting the paper thus covered with textile material into a blank of proper size, forming said blank into a truncated pyramid having a rectangular cross section, and folding said truncated pyramid along said slits while using the enlarged ends of said slits as guides for certain of the corners of said folds.

12. The method of forming a camera bellows which comprises applying adhesive to both sides of a sheet of paper, punching several series of parallel slits in trapezoidal areas of a section of said paper corresponding to the developed surfaces of the sides of a truncated pyramid having a rectangular base, said slits being so arranged that they define rectangular lines of weakness in the section when folded into a bellows, covering both sides of said paper with light-proof textile material, cutting the paper thus covered with textile material along the margins of the section, forming said section into a truncated pyramid, and folding said truncated pyramid along said rectangular lines of weakness in said section.

13. The method of forming a four sided camera bellows which comprises making four series of slots in a single sheet of material, at least two of said four series of slots being of the same pattern, covering the slotted material with imperforate material and folding the four sides until the edges abut, fastening the edges and folding the four sides being guided by the slotted material.

14. The method of forming a camera bellows which comprises punching a series of

slots adapted to form four bellows walls out of a single sheet of material with the slots so arranged that an integral perforated sheet remains, the pattern of the perforations being arranged in pairs at least two of which are similar, and folding the punched out integral sheet and joining together the two free edge thereof into the form of a truncated pyramid.

15. A blank for a bellows support formed from a single piece of material adapted to be folded into a four sided bellows support with open ends, said blank having a series of slots therein for defining parts to be folded, and relatively narrow strips of material extending across the ends of the slots defining the parts to be folded whereby the narrow strip may form reinforcing strip for holding the folds in place.

16. A bellows for a folding camera comprising a single reticular support, said reticular support including sets of interstices with parallel sides, other sets of interstices with non-parallel sides, one set forming guides for folds in the sides of the bellows and the other set forming guides for the corner folds.

17. A bellows for a folding camera comprising a single reticular support, said reticular support including sets of interstices with parallel sides, other sets of interstices with non-parallel sides, one set forming guides for folds in the sides of the bellows and the other set forming guides for the corner folds, and a cover pasted over the reticular support and interstices.

18. A bellows for a folding camera including a single sheet of reticular material having a plurality of sets of interstices with parallel sides, each set of interstices with parallel sides being arranged at an angle to the next adjacent set, and a plurality of sets of interstices with angularly disposed sides, a cover for the reticular material, said sheet and cover being foldable along lines defined by said interstices.

19. A bellows for a folding camera including a single sheet of reticular material having a plurality of sets of interstices with parallel sides, each set of interstices with parallel sides being arranged at an angle to the next adjacent set and interstices extending between the sets of interstices with parallel sides adapted to define corner folds of said bellows.

20. A bellows for a folding camera comprising a single reticular support having interstices with parallel sides, said interstices being arranged in sets adapted to form a plurality of sides for said bellows, interstices having a shape adapted to define corner folds in said bellows and relatively narrow bands of material of the reticular support connecting the fold support.

21. A bellows for folding cameras including a single slotted sheet said slotted sheet having slots divided into sets corresponding

to the number of sides of the bellows and certain of said slots having edges adapted to define the corner folds between the sides of the bellows.

5 22. A bellows for a folding camera including a single slotted sheet adapted to form a support for all four sides of the bellows and including openings with non-parallel sides adapted to define corner folds between the  
10 sides of the bellows.

Signed at Rochester, New York this 28th day of May 1930.

JAMES A. NOBLE.

15

20

25

30

35

40

45

50

55

60

65