



(12) **EUROPEAN PATENT SPECIFICATION**

(45) Date of publication and mention
of the grant of the patent:

18.05.2005 Bulletin 2005/20

(21) Application number: **97945553.2**

(22) Date of filing: **30.09.1997**

(51) Int Cl.7: **C23C 30/00, F28F 19/06**

(86) International application number:
PCT/US1997/018122

(87) International publication number:
WO 1998/017841 (30.04.1998 Gazette 1998/17)

(54) **ADVANCED GALVANIC CORROSION PROTECTION**

FORTGESCHRITTENE GALVANISCHE KORROSIONSSCHUTZ

PROTECTION AMELIOREE CONTRE LA CORROSION GALVANIQUE

(84) Designated Contracting States:
DE ES FR GB IT NL

(30) Priority: **21.10.1996 US 734145**
21.10.1996 US 734146

(43) Date of publication of application:
20.10.1999 Bulletin 1999/42

(73) Proprietor: **CARRIER CORPORATION**
Syracuse New York 13221 (US)

(72) Inventor: **GAROSSHEN, Thomas, J.**
Glastonbury, CT 06033 (US)

(74) Representative: **Leckey, David Herbert et al**
Frank B. Dehn & Co.,
European Patent Attorneys,
179 Queen Victoria Street
London EC4V 4EL (GB)

(56) References cited:
EP-A- 0 263 592 FR-A- 2 179 317
GB-A- 2 284 882

- DATABASE WPI Section Ch, Week 7901 Derwent Publications Ltd., London, GB; Class M21, AN 79-00793B XP002053341 & JP 53 132 449 A (SHOWA ALUMINIUM CO LTD), 18 November 1978
- PATENT ABSTRACTS OF JAPAN vol. 007, no. 133 (M-221), 10 June 1983 & JP 58 049898 A (MITSUBISHI JUKOGYO KK), 24 March 1983,

- PATENT ABSTRACTS OF JAPAN vol. 008, no. 216 (M-329), 3 October 1984 & JP 59 100399 A (NIPPON RADIATOR KK), 9 June 1984,
- PATENT ABSTRACTS OF JAPAN vol. 008, no. 207 (M-327), 21 September 1984 & JP 59 095397 A (NIPPON RADIATOR KK), 1 June 1984,
- DATABASE WPI Section Ch, Week 8812 Derwent Publications Ltd., London, GB; Class J08, AN 88-081220 XP002053342 & JP 63 034 495 A (NIPPONDENSO CO LTD), 15 February 1988
- DATABASE WPI Section Ch, Week 8604 Derwent Publications Ltd., London, GB; Class J08, AN 86-024451 XP002053343 & JP 60 245 787 A (MATSUSHITA ELEC IND CO LTD), 5 December 1985
- PATENT ABSTRACTS OF JAPAN vol. 006, no. 163 (M-152), 26 August 1982 & JP 57 077894 A (TSUCHIYA MFG CO LTD), 15 May 1982,
- PATENT ABSTRACTS OF JAPAN vol. 016, no. 057 (M-1210), 13 February 1992 & JP 03 255895 A (HITACHI CABLE LTD), 14 November 1991,
- PATENT ABSTRACTS OF JAPAN vol. 010, no. 044 (M-455), 21 February 1986 & JP 60 194291 A (HITACHI PLANT KENSETSU KK), 2 October 1985,
- PATENT ABSTRACTS OF JAPAN vol. 016, no. 515 (M-1329), 23 October 1992 & JP 04 190096 A (SKY ALUM CO LTD), 8 July 1992,
- PATENT ABSTRACTS OF JAPAN vol. 009, no. 271 (C-311), 29 October 1985 & JP 60 121264 A (NIPPON KOGYO KK), 28 June 1985,

Note: Within nine months from the publication of the mention of the grant of the European patent, any person may give notice to the European Patent Office of opposition to the European patent granted. Notice of opposition shall be filed in a written reasoned statement. It shall not be deemed to have been filed until the opposition fee has been paid. (Art. 99(1) European Patent Convention).

Description

[0001] This invention relates generally to protecting metals from a corrosive environment, and more specifically to protecting copper-aluminum heat exchangers for use in air conditioners.

[0002] Galvanic corrosion occurs when two dissimilar metals make contact with one another in the presence of an electrolyte thereby forming a galvanic couple. The more noble metal (higher on the galvanic series) provides the surface area for the reduction reaction and the less noble metal (lower on the galvanic series) corrodes in an oxidation process. The oxidation occurs in the greatest amount at the interface of the two metals but may also occur at some distance away from the actual interface. In coastal regions, the most common electrolyte is salt water in the air. A fine salt water mist may be blown inland for up to fifty miles from the coast. Sulfur dioxide from industrial pollution also creates an electrolyte when it combines with moisture in the air.

[0003] A common method of preventing galvanic corrosion has been to coat the exposed surfaces of the metals with various types of paint. These protective coatings have met with only limited success for a number of reasons. The main problem with coatings is that their effectiveness at preventing corrosion is degraded by exposure to the environment such as ultraviolet light and acid rain. Another common problem is that the coating materials often do not adhere well to the metal substrates and eventually flake off or erode away exposing the metal substrates. Moreover, such protective coatings are somewhat porous and allow the electrolyte to penetrate the surface of the substrates and connect the galvanic couple. In addition, the application of protective coatings to the surfaces of certain articles can negatively affect their performance.

[0004] Attempts have been made, with varying degrees of success, to coat conventional copper-aluminum heat exchangers with various materials in an effort to extend the useful life of the unit. These coating materials oftentimes reduce the heat transfer capability of the unit, exhibit poor adhesion properties and fail to penetrate into all the areas that might be exposed to a hostile environment.

[0005] Japanese patent publication JP 53 132 449 A discloses a heat exchanger manufactured from an iron pipe and aluminum fins wherein the entire assembly is coated with an aluminum braze clad. British patent publication GB 2 284 882 A discloses a fin and tube heat exchanger manufactured from a tube, preferably steel, which is coated with a metallic coating, in particular a soft malleable metallic coating, to provide a corrosion barrier on the tube to prevent corrosion of the tube itself and to improve bonding between the tube and the fins. French patent publication FR 2 179 317 A discloses a heat exchanger manufactured from copper tubes and aluminum fins wherein the tube is coated with a solder applied via a hot dip process to a thickness of 20 to 50

micrometers. Japanese patent publication JP 63 034 495 A discloses a heat exchanger having aluminum fins and an aluminum alloy tube which is flame-coated with an aluminum alloy braze which may contain zinc.

[0006] According to the invention there is provided a method as defined in Claim 1. Optional features are defined in the dependent claims.

[0007] In general the present invention relates to an advanced galvanic corrosion protection method. In an article made of two metals, one being more noble than the other, the outer surface of the more noble metal is treated with a metal which is more galvanically compatible with the less noble metal than the more noble metal is galvanically compatible with the less noble metal prior to assembly to form a protective layer on the surface of the more noble metal and between the less noble metal and the more noble metal whereby galvanic corrosion of the less noble metal is reduced. Through optimal selection of the treatment metal applied to the more noble metal, the invention greatly reduces the oxidation reduction process which causes corrosion of the less noble metal, for example an aluminum fin mounted on a copper tube of a heat exchanger, in the presence of an electrolyte.

FIG. 1 is a perspective view of a heat exchanger incorporating heat exchanger tubes treated in accordance with the present invention.

[0008] As will be described in detail below the present invention will be described in to providing for galvanic corrosion protection of a copper-aluminum heat exchanger. However, it should be evident to one skilled in the art that the present invention is not limited to this specific example and could be used in connection with a number of arrangements where dissimilar metals are in contact with one another in the presence of an electrolyte.

[0009] FIG. 1 illustrates a fin/tube heat exchanger 10 of the type typically used in air conditioning units. The heat exchanger includes one or more flow circuits for carrying refrigerant through the heat exchanger unit. For the purposes of explanation, the heat exchanger 10 contains a single flow circuit tube 2 consisting of an inlet line and an outlet line 4 which are connected at one end of the heat exchanger 10 by means of a 90° tube bend 5. It should be evident, however, that more circuits may be added to the unit depending upon the demands of the system. The unit further includes a series of fins 6 comprising radial disposed plate like elements spaced along the length of the flow circuit. The fins 6 are supported in the assembly between a pair of end plates 7 and 8 to define a gas flow passage through which a gas passes over the extension of the tube 2 and between the spaced fins 6.

[0010] As noted above, heat exchangers of this type are commonly exposed in use to corrosive environments. In a typical arrangement heat exchangers of this

type are fabricated utilizing copper tubes for the circuit flow tubes and aluminum for the fins. The fins are disposed in contact with the tubes and draw heat away from the tubes through conductive heat transfer and then dissipate the heat through convective heat transfer to the gas (commonly air) flowing over the tubes. Copper is utilized in tube construction because of its good heat transfer properties, general resistance to corrosion, and ease of repair. The fins are fabricated from aluminum because of its good heat transfer properties, ease of fabrication, and low cost. Heat exchangers fabricated entirely from copper, as well as entirely from aluminum, are utilized in certain applications to avoid the problems of galvanic corrosion but at the cost of trades characterized above.

[0011] Aluminum is significantly lower on the galvanic series, i.e. less noble, than copper. It is for this reason that the aluminum oxidizes or corrodes when it is in contact with copper in the presence of an electrolyte. In the arrangement shown in FIG. 1, the interface of the tube and fin is where the galvanic couple is made and where the corrosion of the aluminum fins occurs. Once the fin has corroded at the intersection the fin is no longer in contact with the tube and thus the heat exchanger efficiency is greatly reduced because the fin loses its ability to conduct heat away from the tube.

[0012] As will be explained in greater detail below, in accordance with the present invention the exposed surfaces of the tubes 2 are coated or enriched with aluminum or a metal more galvanically compatible with aluminum. Aluminum is the best candidate material since a galvanic couple will not form between the aluminum coating and the aluminum fins 6. However, such active metals such as zinc, tin, magnesium, gallium, cadmium and lead will also reduce the extent of the galvanic couple and thus the rate of oxidation of the fin material.

[0013] The coating or surface enrichment of the copper tubes 12 with aluminum is accomplished prior to the assembly of the heat exchanger 10. The aluminizing of copper is a well known practice and can be accomplished to a degree of precision so as to virtually eliminate the above cited problems with conventional coating for corrosion protection. Several processes for aluminizing the copper tubes are known in industry and contemplated by the present invention. The coating processes include hot dipping, electroplating, aluminum filled painting and slurries, and thermal spraying. The surface enrichment processes include ion vapor deposition, chemical vapor deposition, and physical vapor deposition.

[0014] The critical aspect of the present invention is the production of a uniform coating of aluminum over the entire surface of the flow circuit tubes 2. Regardless of the process contemplated the variables of tube surface preparation, tube preheat temperature, coating composition, and coating thickness must be carefully controlled to achieve the proper results of the present invention. The preparation of the exposed surfaces of

the tube is preferred to remove the surface oxide layer from the copper to ensure that the coating material will adhere well to the tube. A number of surface preparation processes are known in industry and include the use of reducing gases, fluxes and shot blasting. The tube preheat temperatures should be controlled between 24 C and 600 C to prevent the dissolution of copper and to limit intermetallic growth during the coating process.

[0015] It is preferred that the coating have high ductility to allow for the subsequent assembly of the heat exchanger without damaging the coating. The ductility of the coating is determined in part by the coating composition and the thickness of the coating. As mentioned above any metallic composition more galvanically compatible with the fin material than the tube material would slow the oxidation rate of the fins 6, while the ideal coating material would exactly match the fin material. Certain aluminum alloys are considered for use in the present invention and they comprise aluminum combined with silicon and aluminum combined with zinc. The coating should advantageously be thick enough to prevent the penetration of the electrolyte. However, as any coating has a somewhat negative effect on the heat transfer of the unit, excessively thick protective layer should be avoided. The optimal range of thickness contemplated by the present invention is .1 mils to 2 mils (2.5 to 51 micrometers).

30 Claims

1. A method of reducing galvanic corrosion of a first less noble metal member in an assembly with a second more noble metal member when the assembly is exposed to an electrolyte, the assembled first less noble metal member having a surface in contact with an exposed surface of the second more noble metal member, comprising the step of treating the exposed surface of the second more noble metal member with a metal more galvanically compatible with the first less noble metal member than the second more noble metal member is galvanically compatible with the first less noble metal member prior to assembling the first less noble metal member to the second more noble metal member whereby a protective layer is formed on the exposed surface of the second more noble metal member and between the first less noble metal member and the second more noble metal member wherein the second more noble metal member consists essentially of copper, the first less noble metal member consists essentially of aluminum, and the treatment metal comprises a metal selected from the group consisting of aluminum, an aluminum alloy containing silicon, an aluminum alloy containing zinc, zinc, tin, magnesium, gallium, cadmium, lead and combinations thereof.

2. The method of claim 1 **characterized in that** the assembly is a heat exchanger wherein the second more noble metal member is a heat transfer tube and the first less noble metal member is at least one metal fin assembled to the outer surface of said heat transfer tube. 5
3. The method of claim 1 or claim 2 wherein the treating step includes a coating process selected from a hot dipping process, an electroplating process, a painting process or a diffusion coating process. 10
4. The method of any preceding claim wherein the layer of treatment metal has a thickness of between 0.0001 inches and 0.002 inches (2.5 to 51 micrometers). 15

Patentansprüche

1. Verfahren zur Verringerung der galvanischen Korrosion eines ersten Teils aus weniger edlem Metall in einer Anordnung mit einem zweiten Teil aus edlerem Metall wenn die Anordnung einem Elektrolyten ausgesetzt wird, wobei das montierte erste Teil aus weniger edlem Metall eine Oberfläche in Kontakt mit einer exponierten Oberfläche des zweiten Teils aus edlerem Metall hat, aufweisend den Schritt des Behandeln der exponierten Oberfläche des zweiten Teils aus edlerem Metall mit einem Metall, das mit dem ersten Teil aus weniger edlem Metall galvanisch verträglicher ist als das zweite Teil aus edlerem Metall mit dem ersten Teil aus weniger edlem Metall galvanisch verträglich ist, vor dem Montieren des ersten Teils aus weniger edlem Metall an das zweite Teil aus edlerem Metall, wodurch an der exponierten Oberfläche des zweiten Teils aus edlerem Metall und zwischen dem ersten Teil aus weniger edlem Metall und dem zweiten Teil aus edlerem Metall eine Schutzschicht gebildet wird, wobei das zweite Teil aus edlerem Metall im Wesentlichen aus Kupfer besteht, das erste Teil aus weniger edlem Metall im Wesentlichen aus Aluminium besteht und das Behandlungsmetall ein Metall aufweist, das ausgewählt ist aus der Gruppe, die aus Aluminium, einer Silizium enthaltenden Aluminiumlegierung, einer Zink enthaltenden Aluminiumlegierung, Zink, Zinn, Magnesium, Gallium, Cadmium, Blei und Kombinationen davon besteht. 20 25 30 35 40 45 50
2. Verfahren nach Anspruch 1, **dadurch gekennzeichnet, dass** die Anordnung ein Wärmeaustauscher ist, bei dem das zweite Teil aus edlerem Metall ein Wärmeübertragungsrohr ist und das erste Teil aus weniger edlem Metall mindestens eine Metallrippe ist, die an die Außenoberfläche des Wärmeübertragungsrohrs montiert ist. 55

3. Verfahren nach Anspruch 1 oder Anspruch 2, bei dem der Behandlungsschritt ein Beschichtungsverfahren beinhaltet, das aus einem Heißtauchverfahren, einem Elektroplattierungsverfahren, einem Anstreich- bzw. Lackierverfahren oder einem Diffusionsbeschichtungsverfahren ausgewählt ist.
4. Verfahren nach einem vorangehenden Anspruch, bei dem die Schicht aus Behandlungsmetall eine Dicke von zwischen 0,0001 inch und 0,002 inch (2,5 bis 51 µm) hat.

Revendications

1. Procédé de réduction de la corrosion galvanique d'un premier élément d'un métal moins noble dans un assemblage avec un second élément d'un métal plus noble lorsque l'assemblage est exposé à un électrolyte, le premier élément de métal moins noble assemblé ayant une surface en contact avec une surface exposée du second élément de métal plus noble, comprenant l'étape de traitement de la surface exposée du second élément de métal plus noble avec un métal galvaniquement plus compatible avec le premier élément de métal moins noble que le second élément de métal plus noble est galvaniquement compatible avec le premier élément de métal moins noble avant l'assemblage du premier élément de métal moins noble avec le second élément de métal plus noble par lequel une couche protectrice est formée sur la surface exposée du second élément de métal plus noble et entre le premier élément de métal moins noble et le second élément de métal plus noble, dans lequel le second élément de métal plus noble est constitué essentiellement de cuivre, le premier élément de métal moins noble est constitué essentiellement d'aluminium, et le métal de traitement comprend un métal choisi parmi le groupe composé de l'aluminium, d'un alliage d'aluminium contenant du silicium, d'un alliage d'aluminium contenant du zinc, du zinc, de l'étain, du magnésium, du gallium, du cadmium, du plomb et de combinaisons de ceux-ci. 20 25 30 35 40 45 50
2. Procédé selon la revendication 1, **caractérisé en ce que** l'assemblage est un échangeur thermique dans lequel le second élément de métal plus noble est un tube de transfert thermique et le premier élément de métal moins noble est au moins une ailette métallique assemblée sur la surface externe dudit tube de transfert thermique.
3. Procédé selon la revendication 1 où 2, dans lequel l'étape de traitement inclut un processus de revêtement choisi parmi un processus de métallisation par immersion, un processus de dépôt électrolytique, un processus de peinture ou un processus de revê-

tement à diffusion.

4. Procédé selon l'une quelconque des revendications précédentes dans lequel la couche de métal de traitement présente une épaisseur comprise entre 0,0001 pouce et 0,002 pouce (2,5 à 51 micromètres).

5

10

15

20

25

30

35

40

45

50

55

5

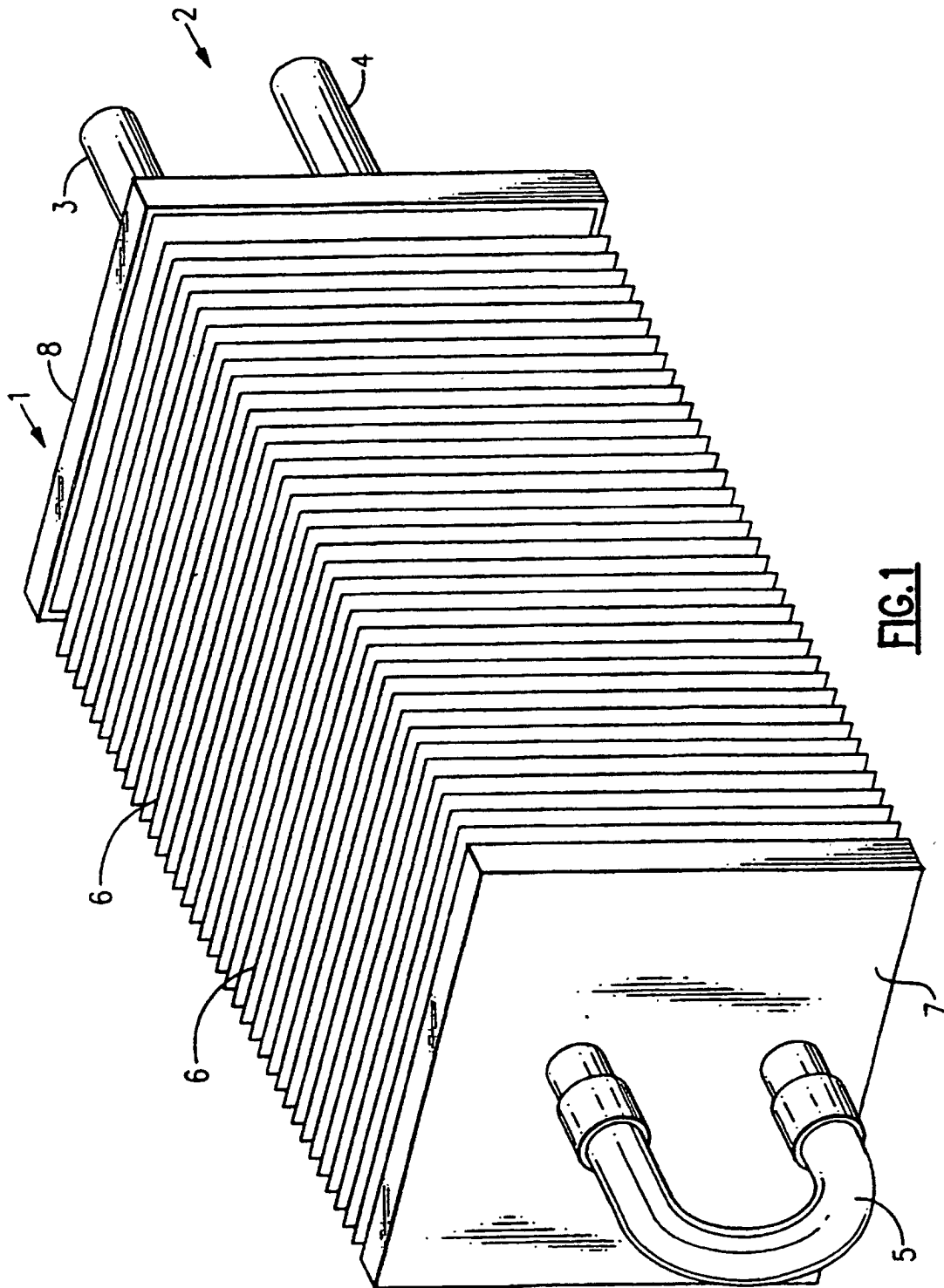

FIG. 1