



(19) **United States**

(12) **Patent Application Publication**
MCCOY

(10) **Pub. No.: US 2009/0327929 A1**

(43) **Pub. Date: Dec. 31, 2009**

(54) **APPLIANCE DEVELOPMENT TOOLKIT WITH EDITOR FOR NAMESPACE ALLOCATION**

(22) Filed: **Sep. 10, 2009**

Related U.S. Application Data

(63) Continuation of application No. PCT/US2009/046186, filed on Jun. 3, 2009.

(60) Provisional application No. 61/058,440, filed on Jun. 3, 2008.

(75) Inventor: **RICHARD A. MCCOY, STEVENSVILLE, MI (US)**

Publication Classification

(51) **Int. Cl.**
G06F 3/048 (2006.01)
G06F 15/16 (2006.01)
H04L 9/32 (2006.01)

(52) **U.S. Cl.** **715/763; 709/206; 726/19**

(57) **ABSTRACT**

An appliance development toolkit has an editor for namespace allocation and an interactive user interface on which the editor is displayed for use by a developer. The editor is used to select or allocate an identifier from a namespace having a universe of identifiers. A method for allocating identifiers from a namespace is also provided.

Correspondence Address:
WHIRLPOOL PATENTS COMPANY - MD 0750
500 RENAISSANCE DRIVE - SUITE 102
ST. JOSEPH, MI 49085 (US)

(73) Assignee: **WHIRLPOOL CORPORATION, BENTON HARBOR, MI (US)**

(21) Appl. No.: **12/556,623**

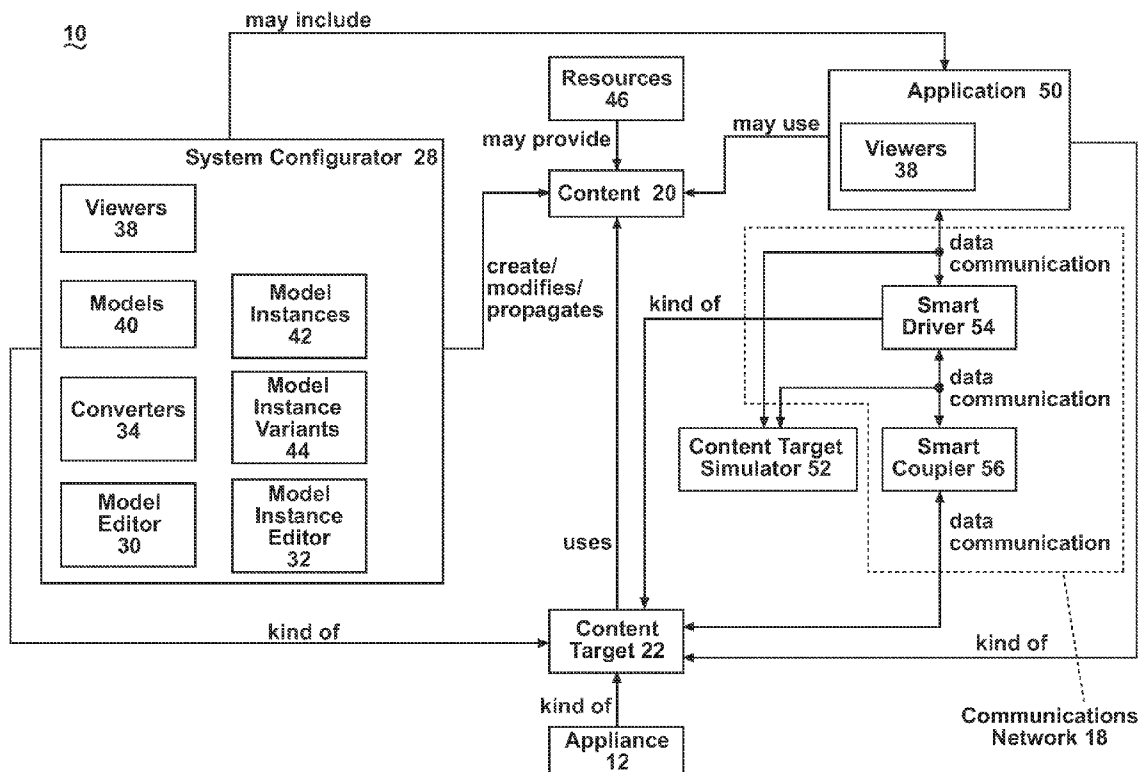

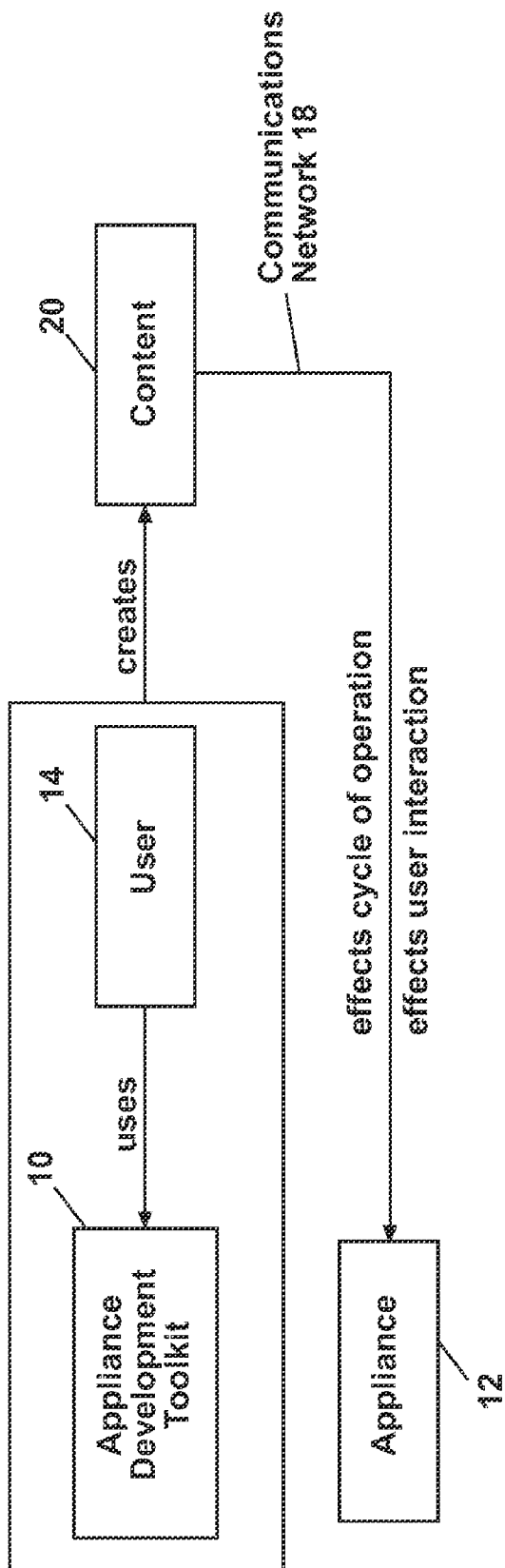

Fig. 1

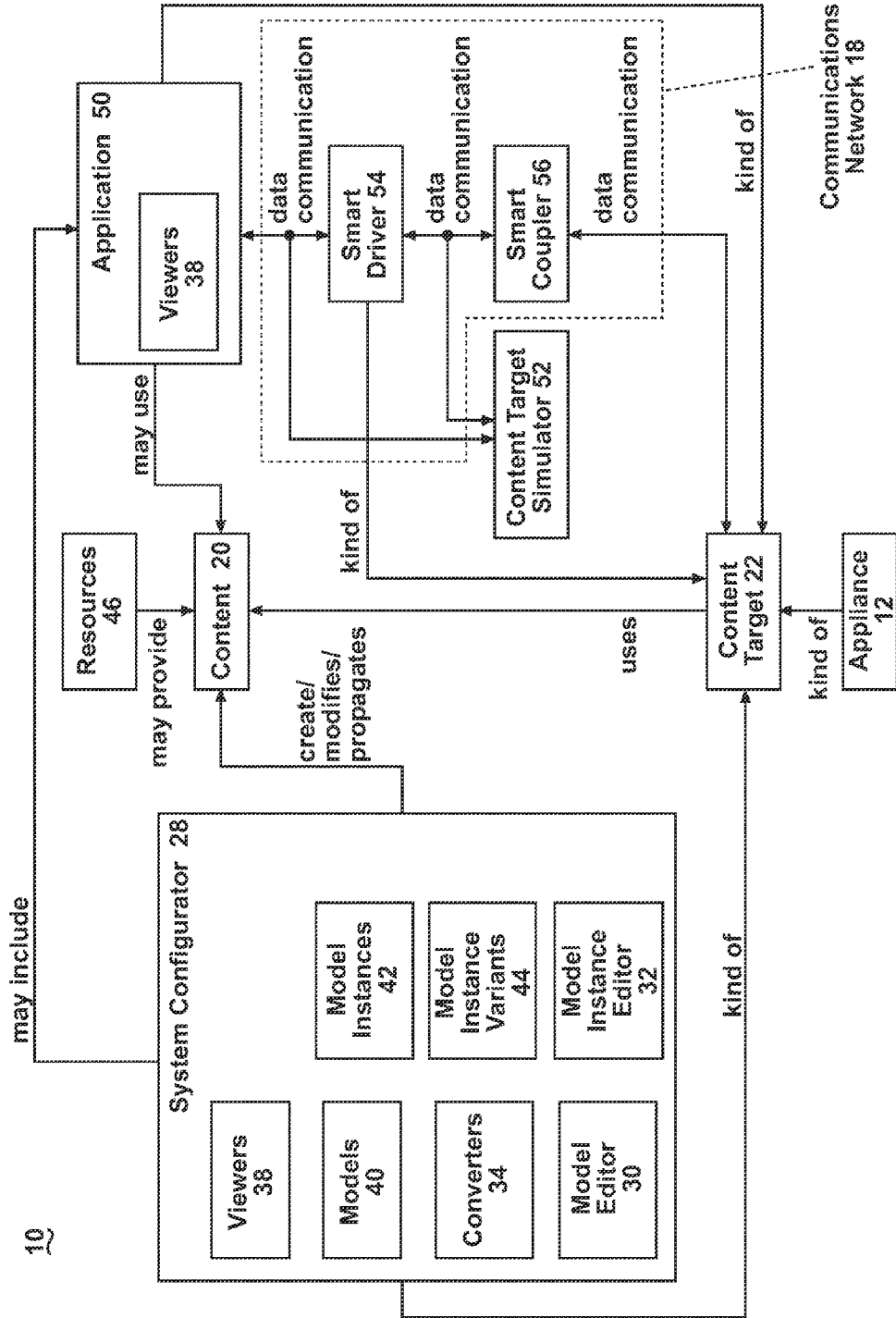

Fig. 2

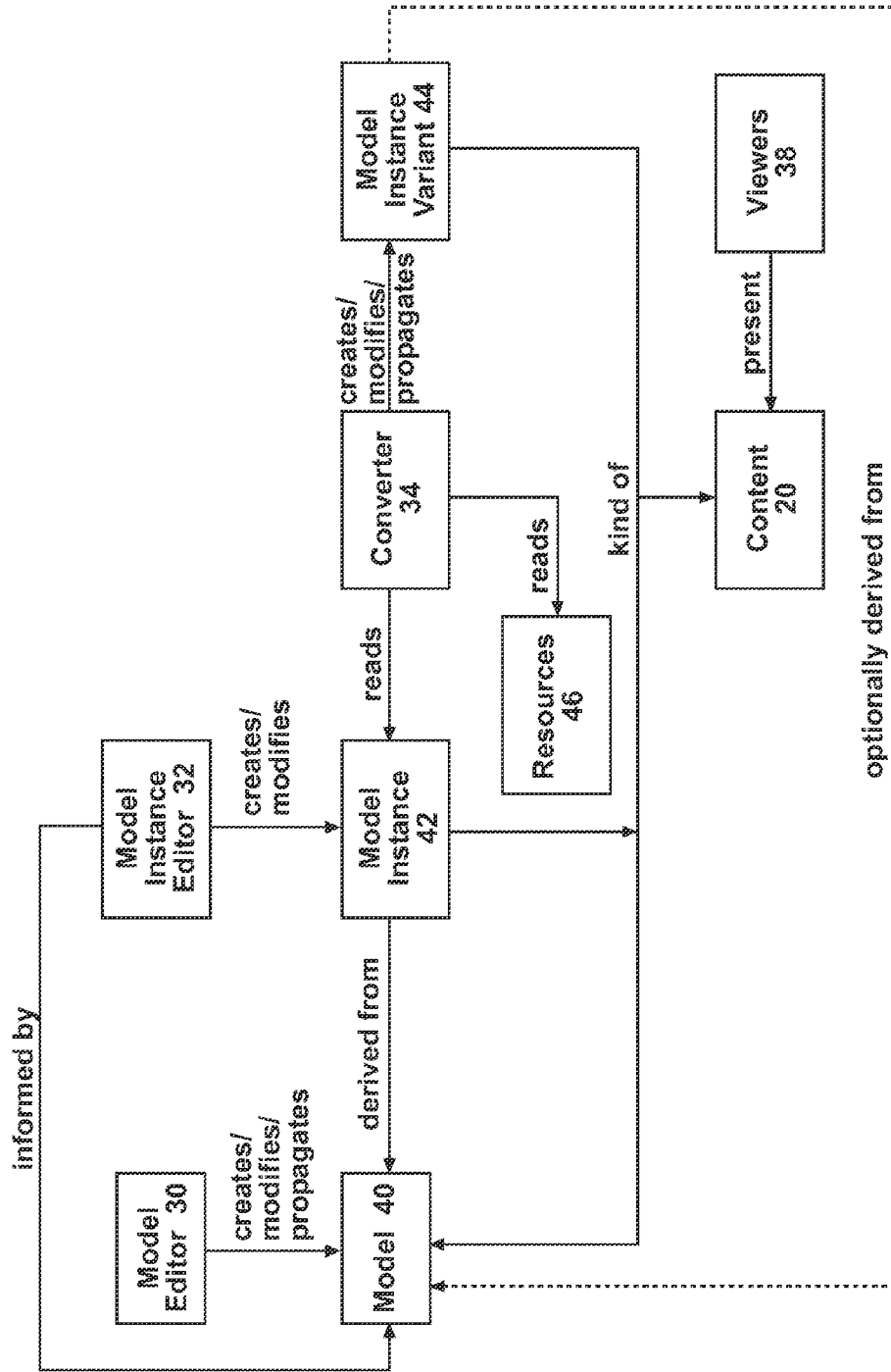

Fig. 3

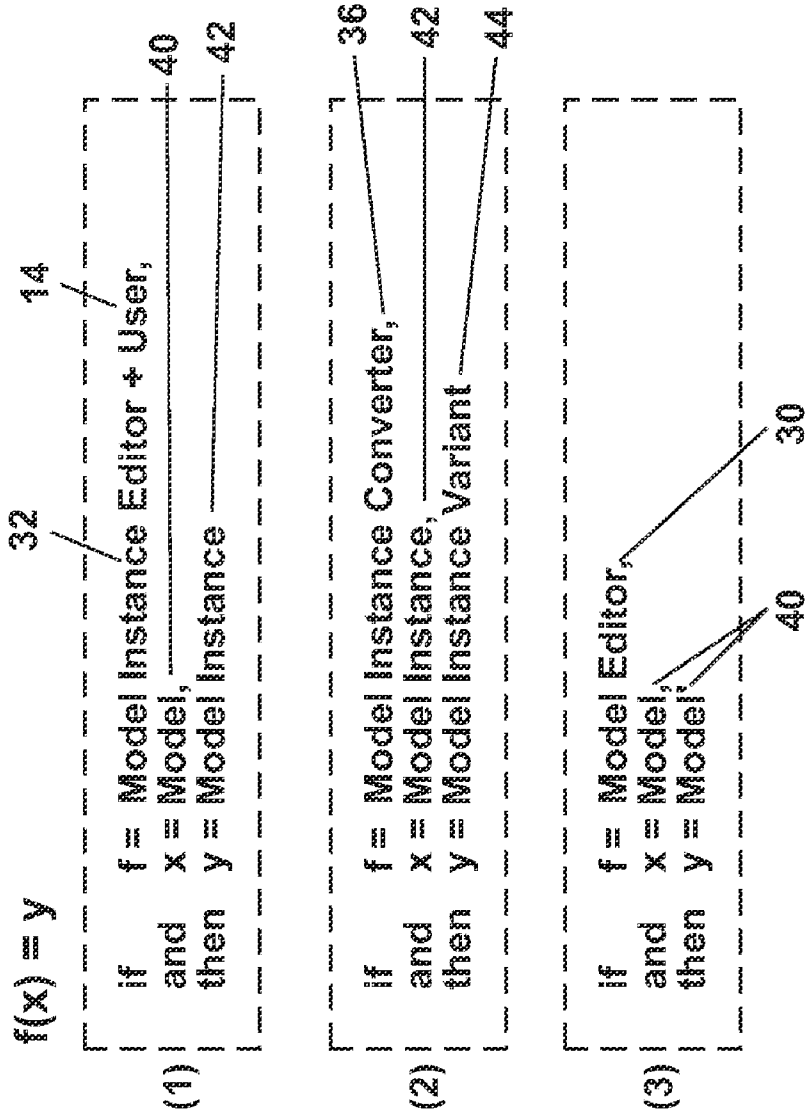

Fig. 4

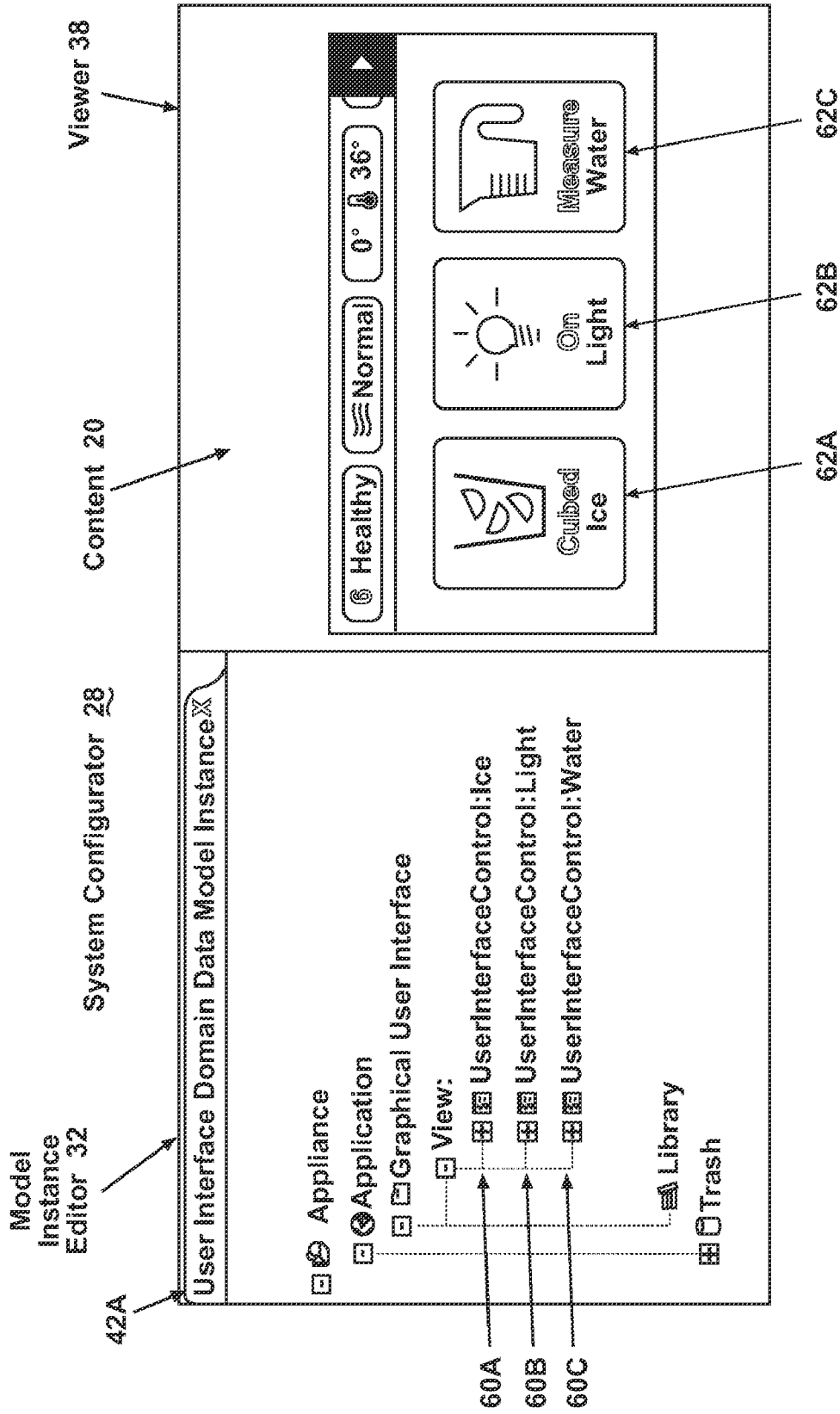

Fig. 5

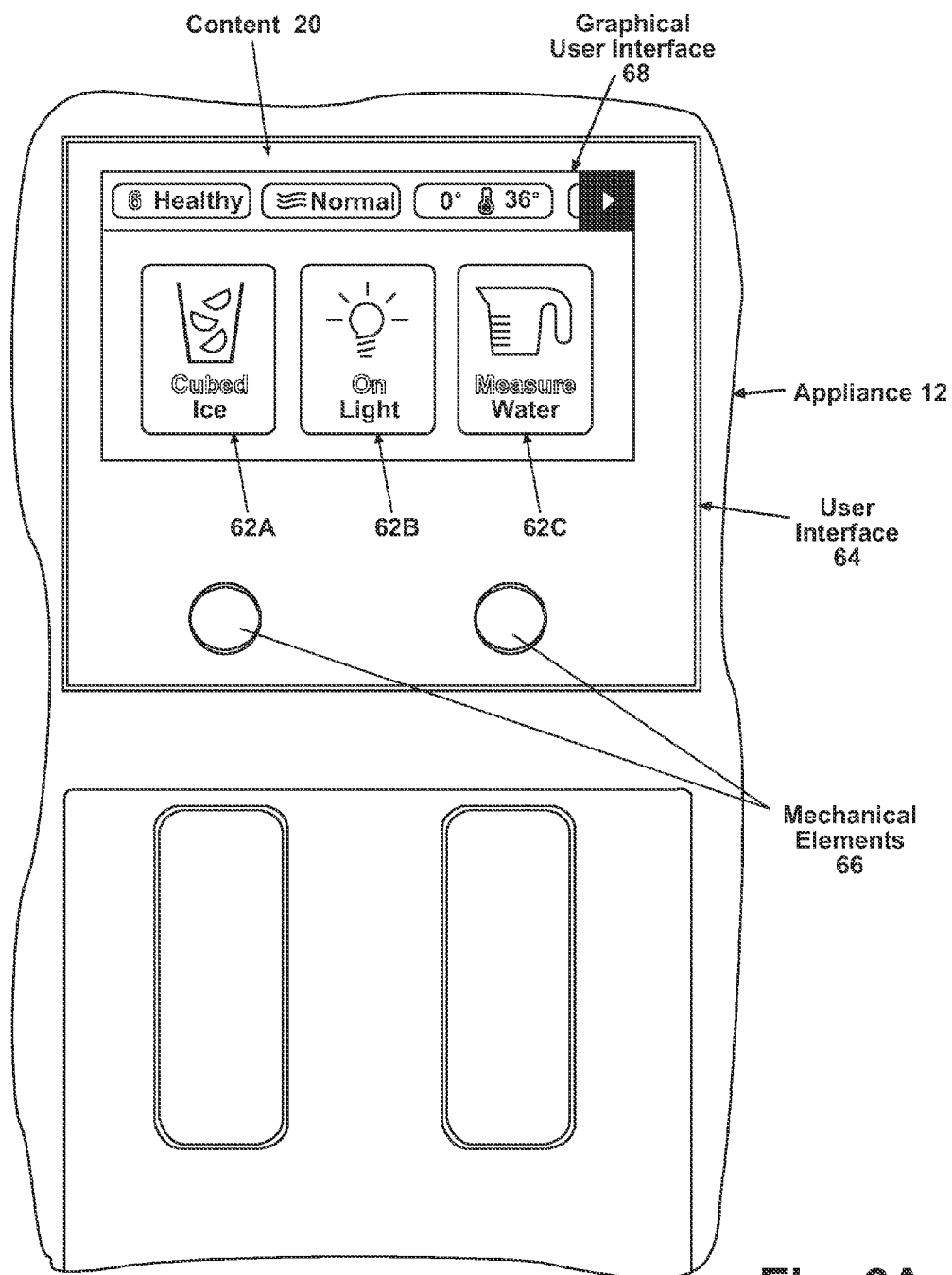

Fig. 6A

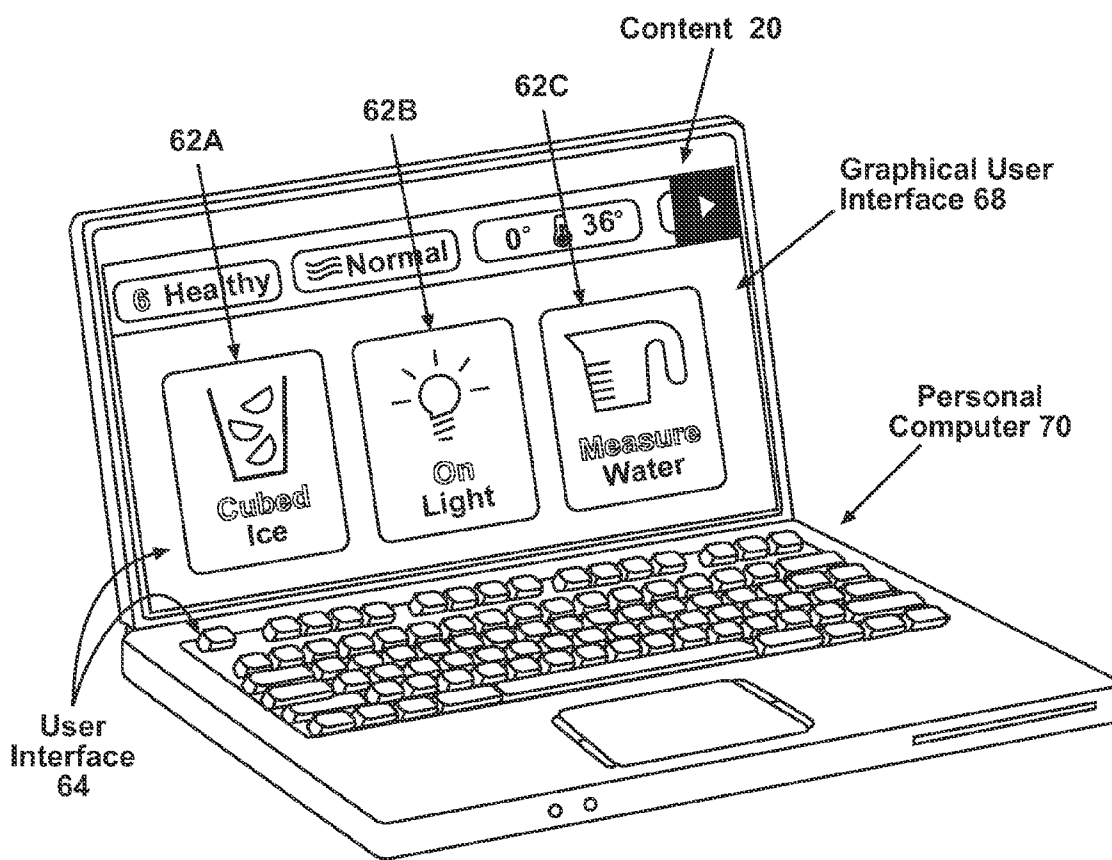

Fig. 6B

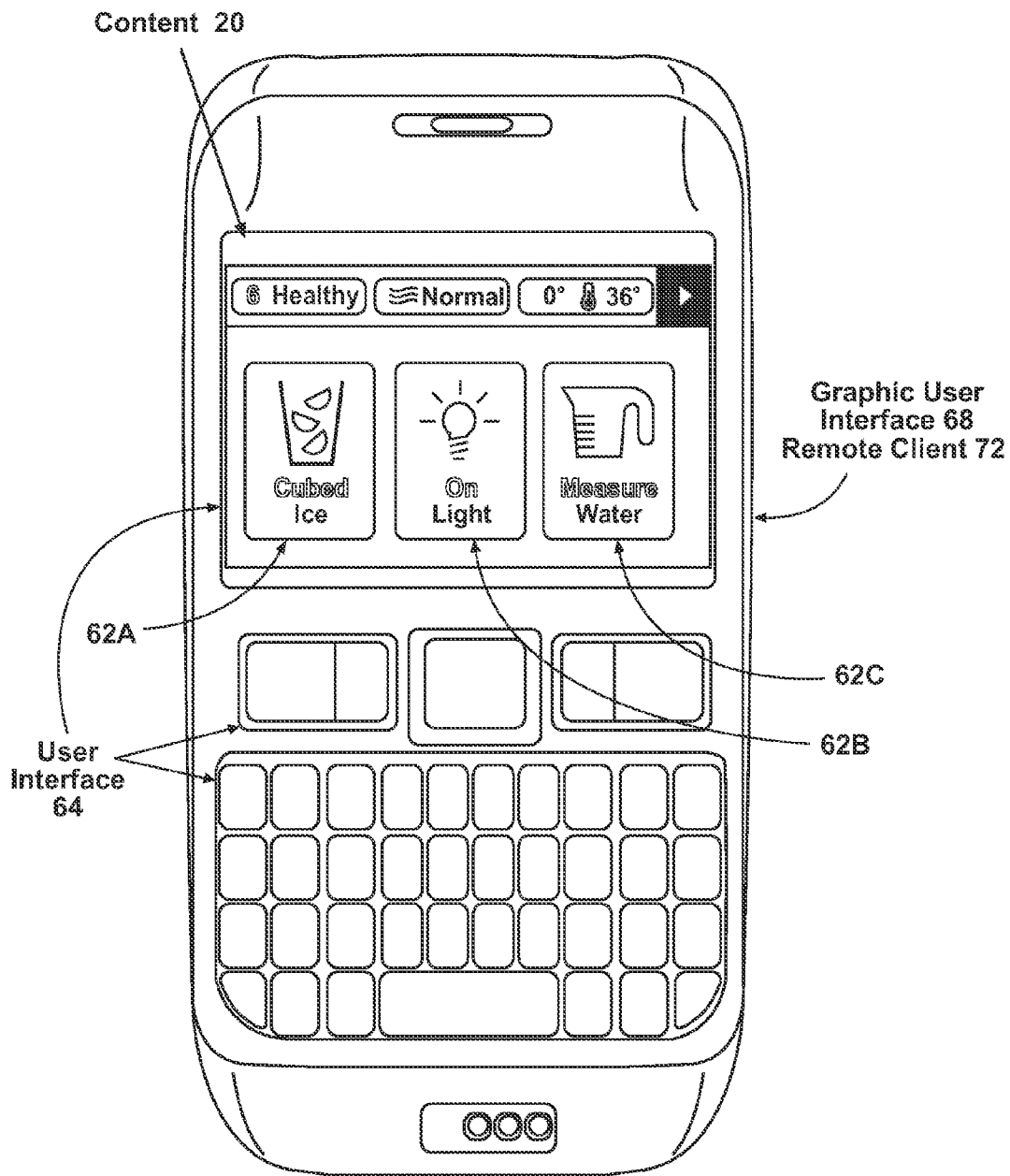

Fig. 6C

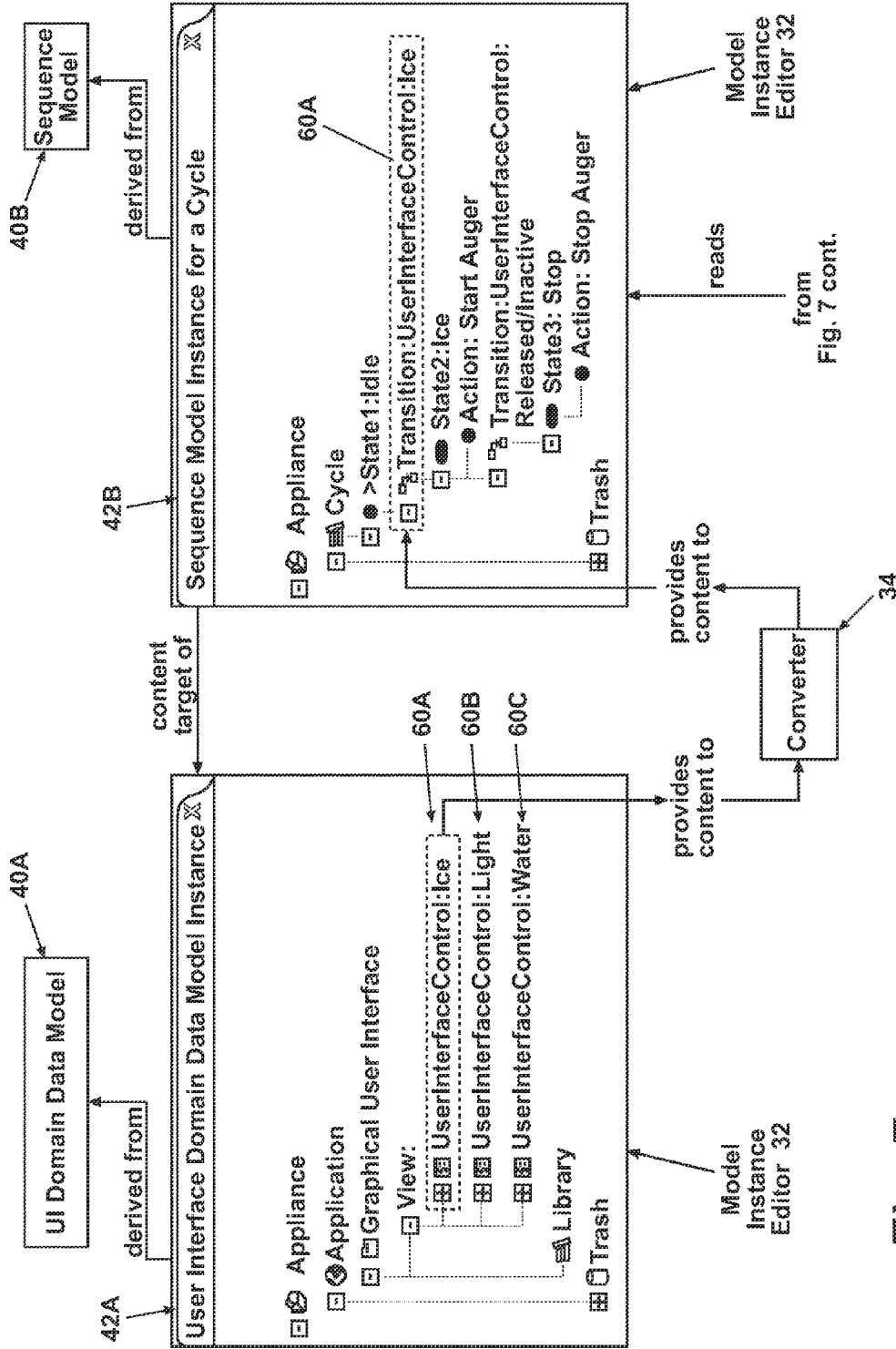

Fig. 7

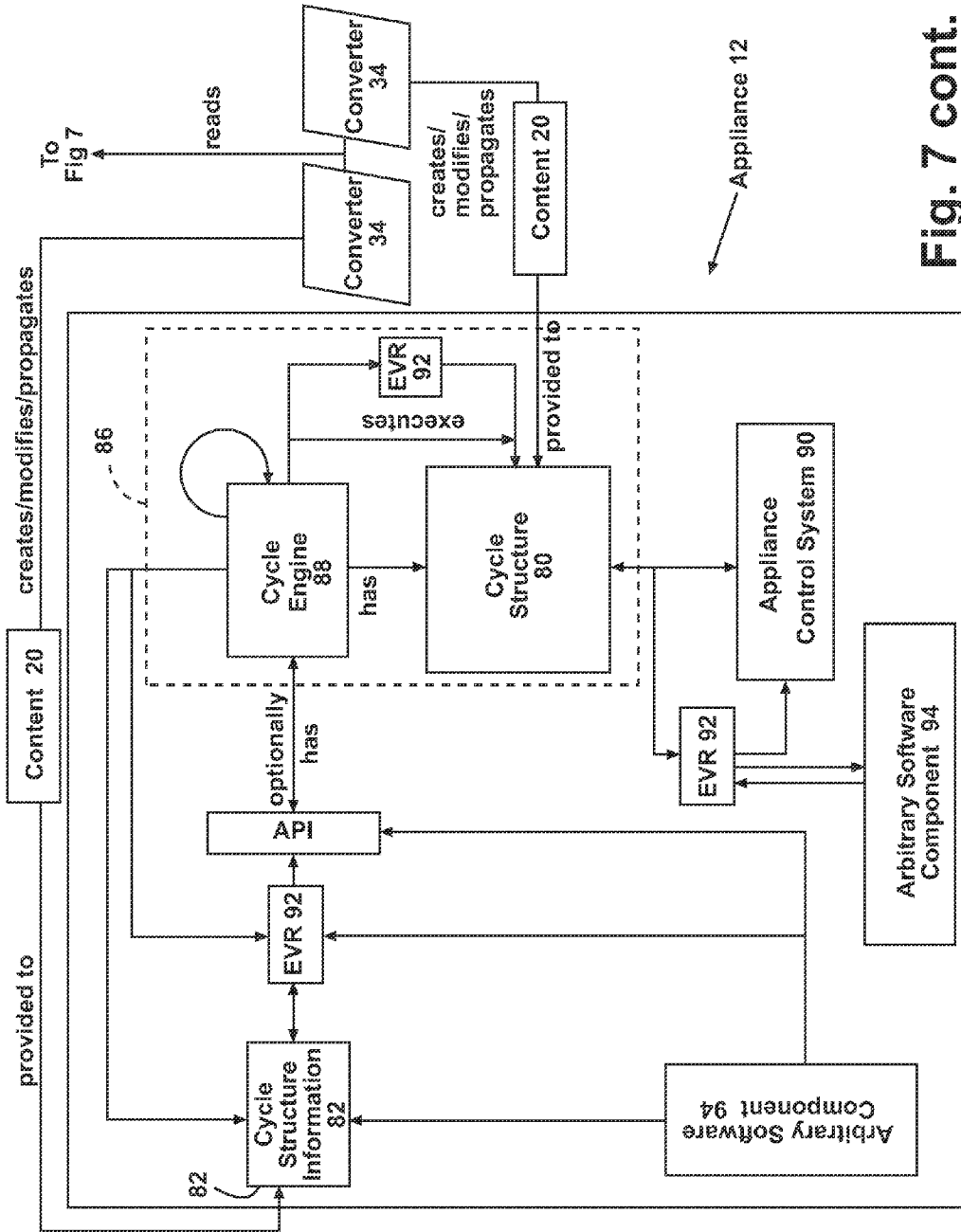

Fig. 7 cont.

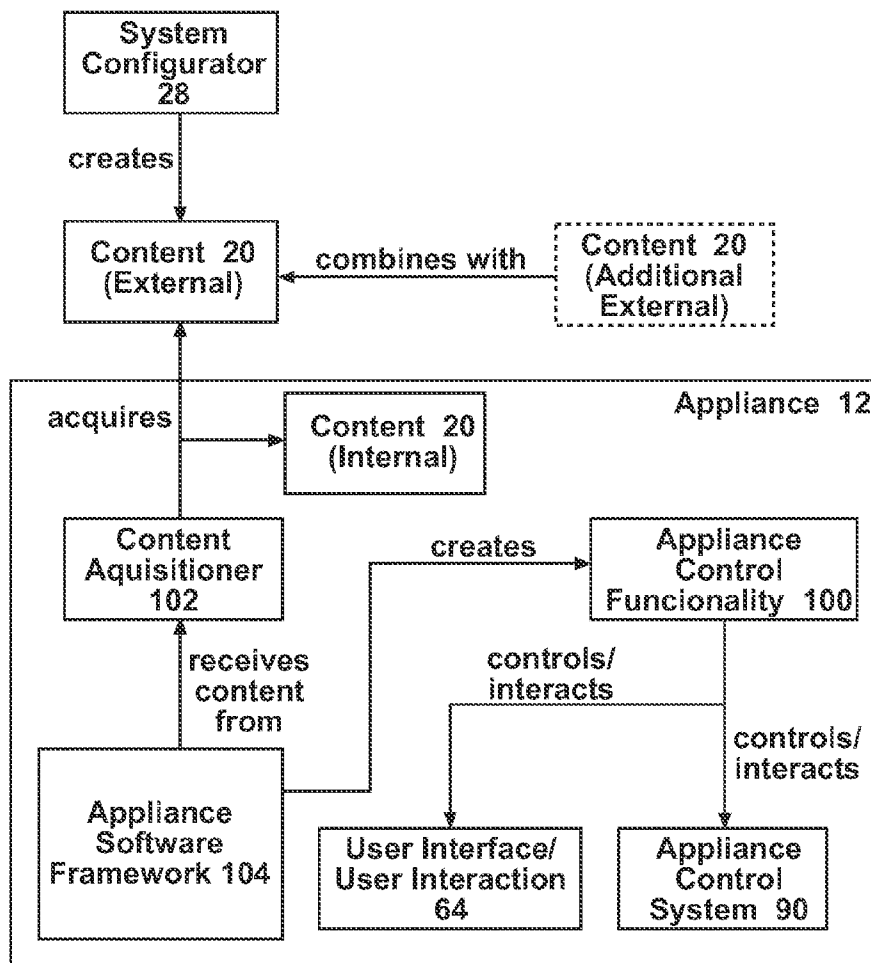

Fig. 8

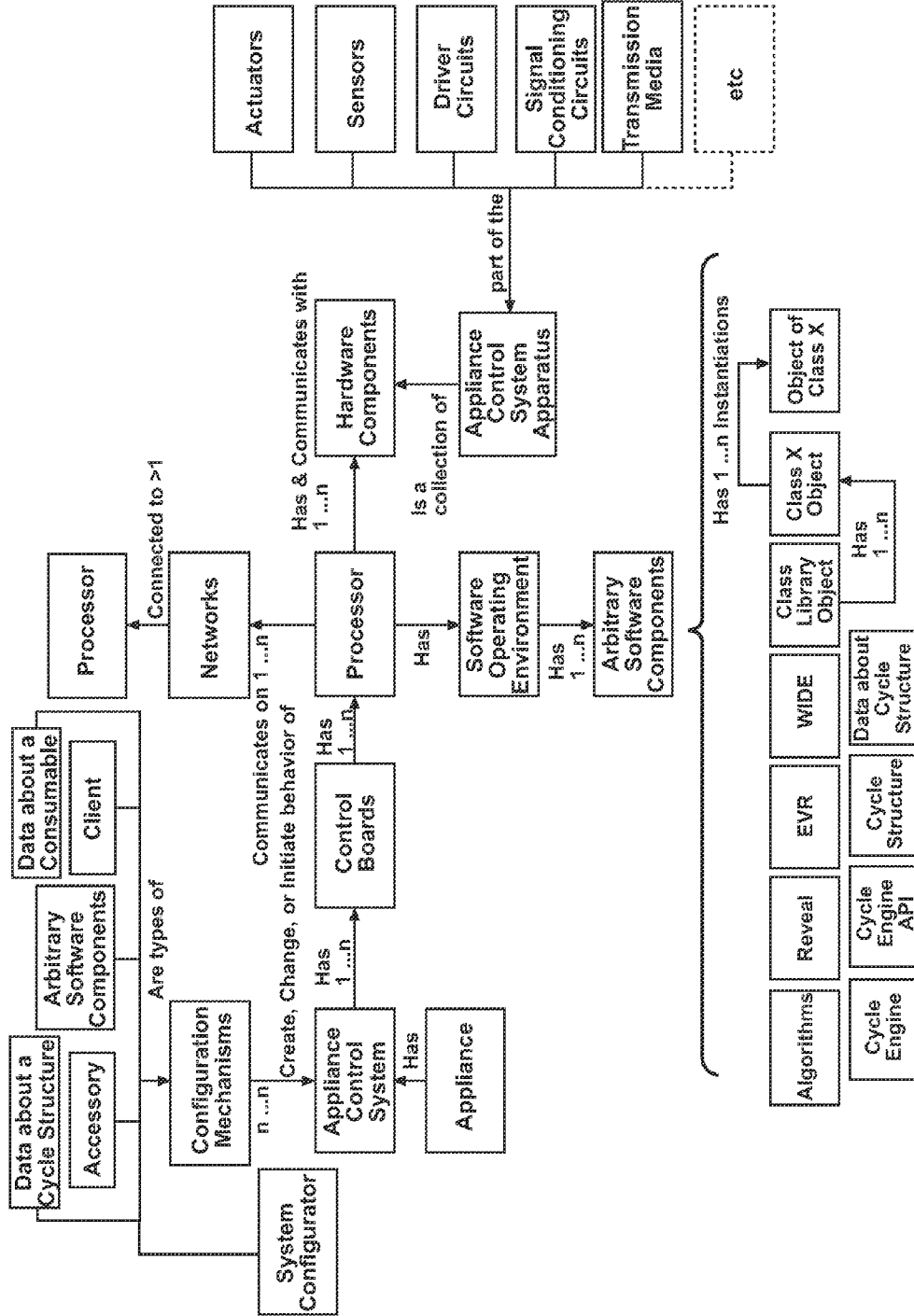

Fig. 9

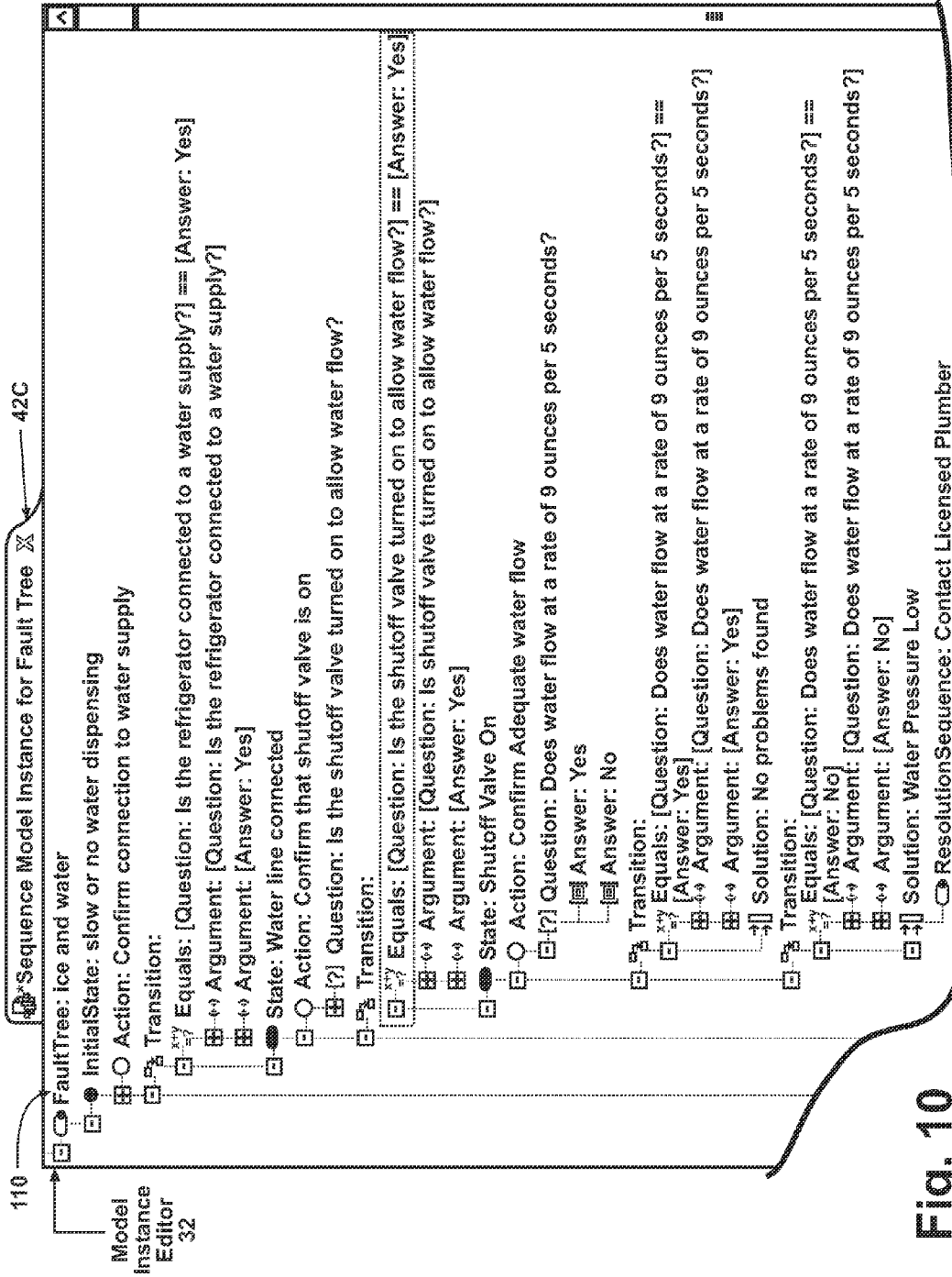



Fig. 10

Model Instance Editor 32

 ^{x,y} Equals: [Question: Is the shutoff valve turn on to allow water flow?] == [Answer: Yes]

120

38

Saddle/shutoff valves are often located either behind the refrigerator or under the sink. Other locations include such places as the basement or crawl space.

124

HTML Text: Refresh Html Source

<img style= (HTML Text)
src= (HTML Text)
alt= (HTML Text) >

OK Cancel

122

Fig. 10A

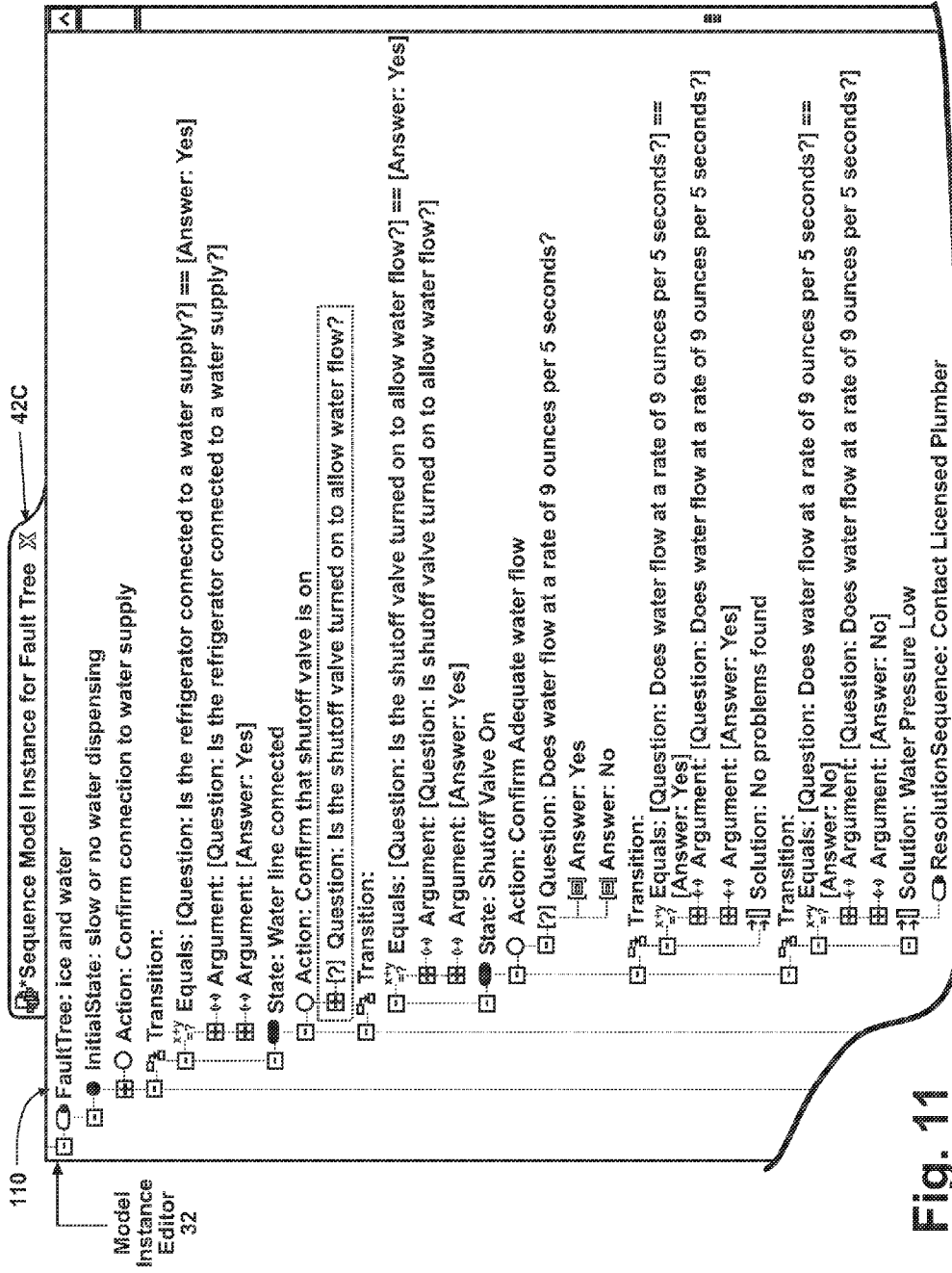

Fig. 11

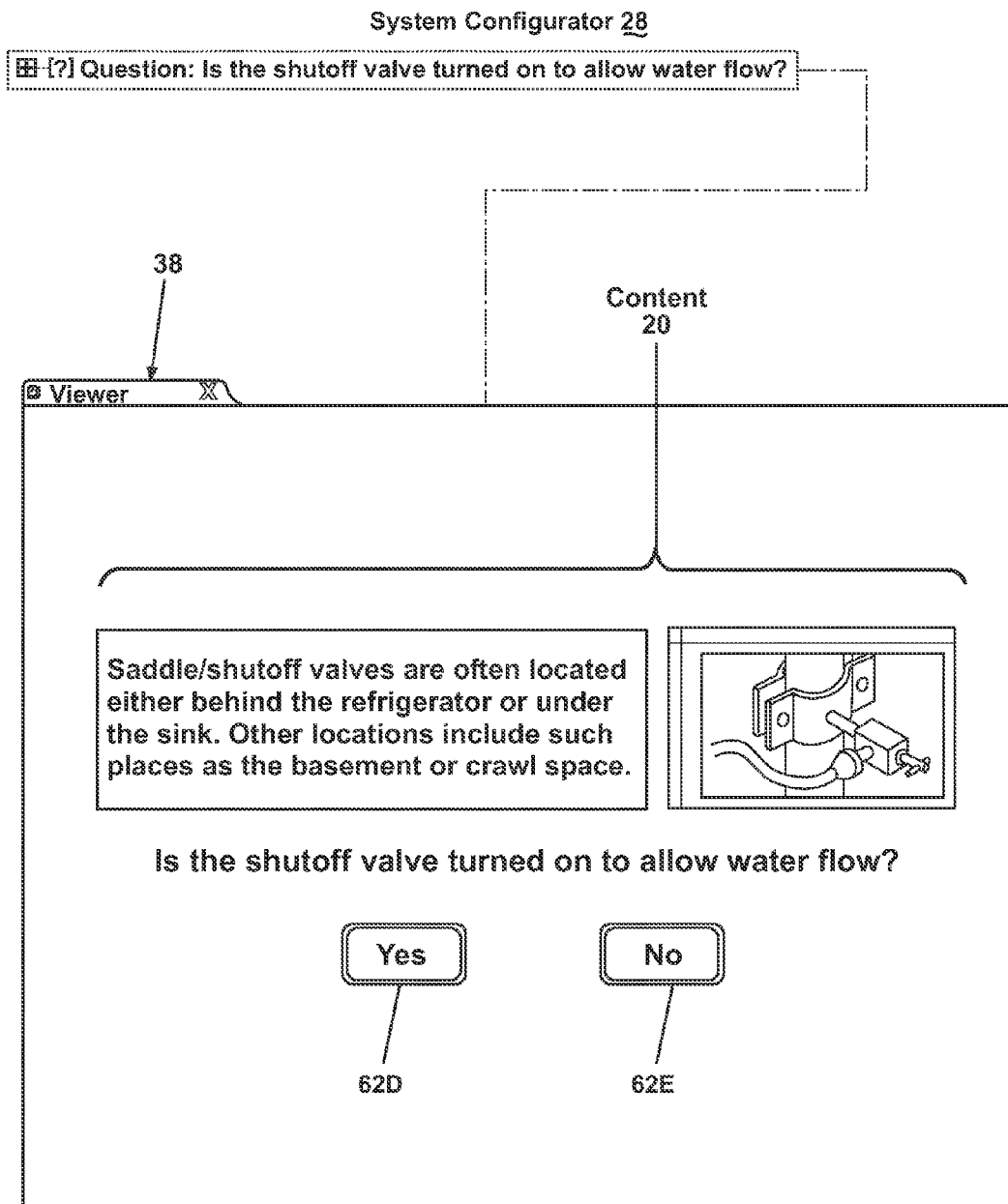

Fig. 11A

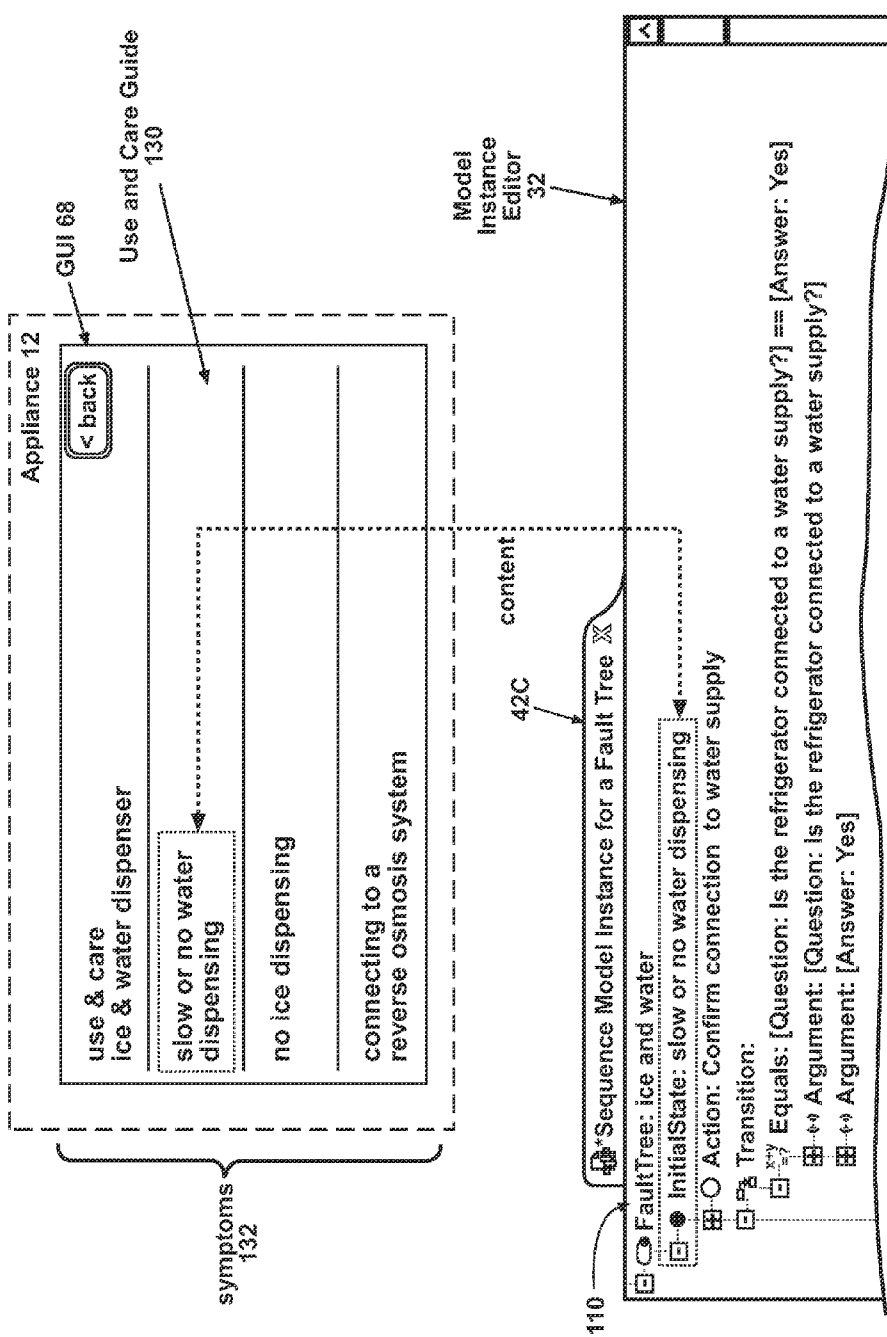

Fig. 12

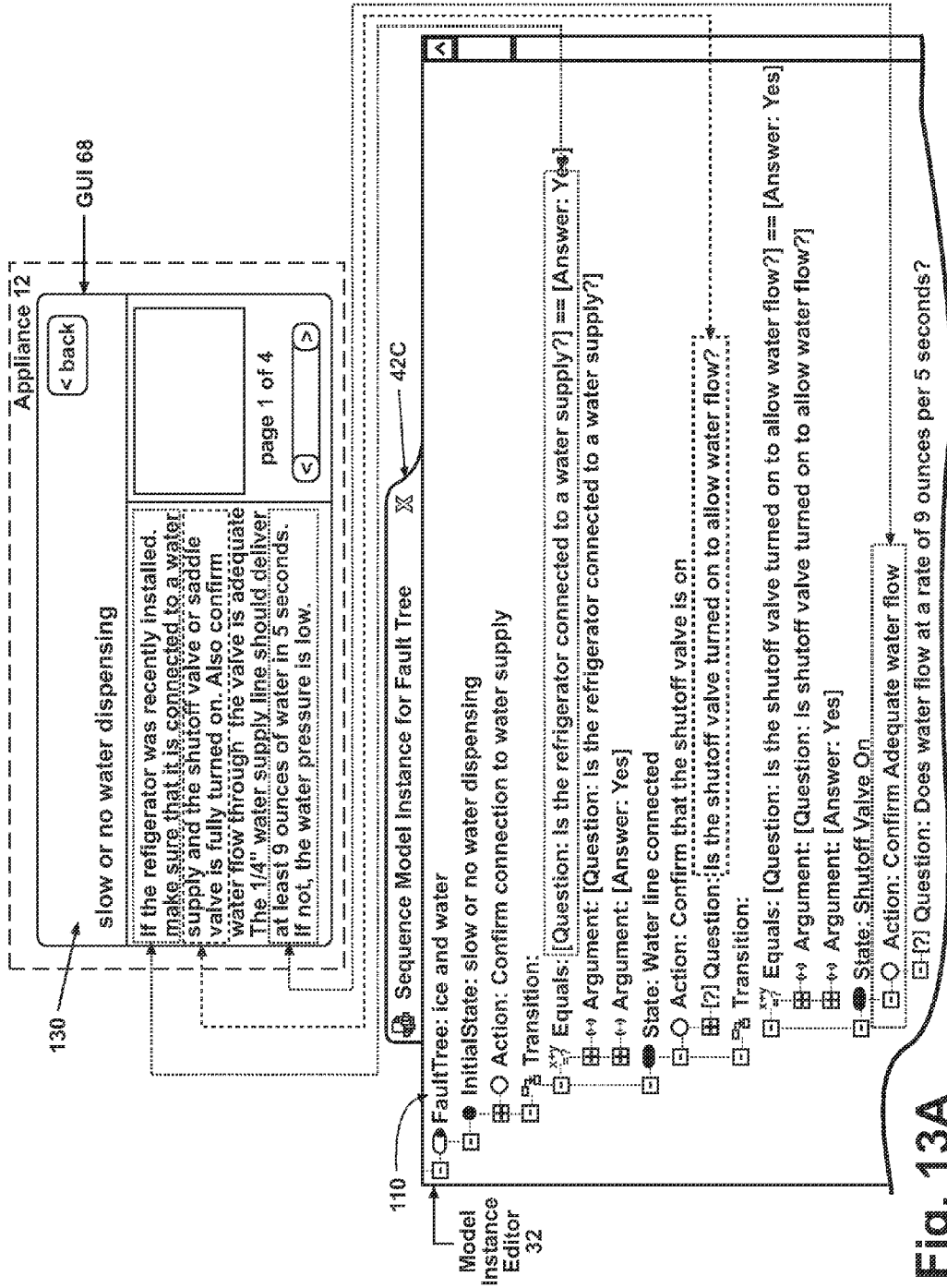

Fig. 13A

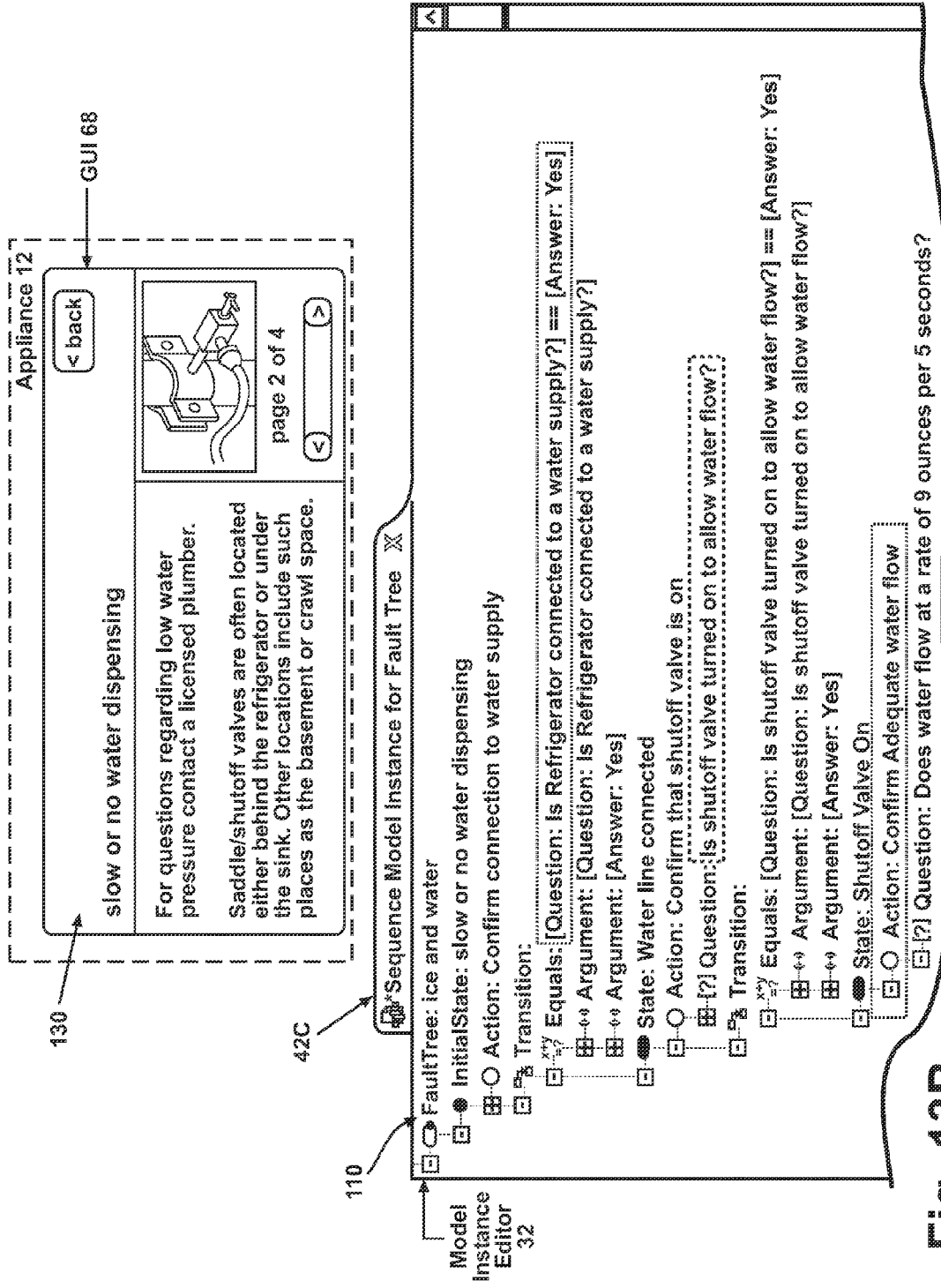

Fig. 13B

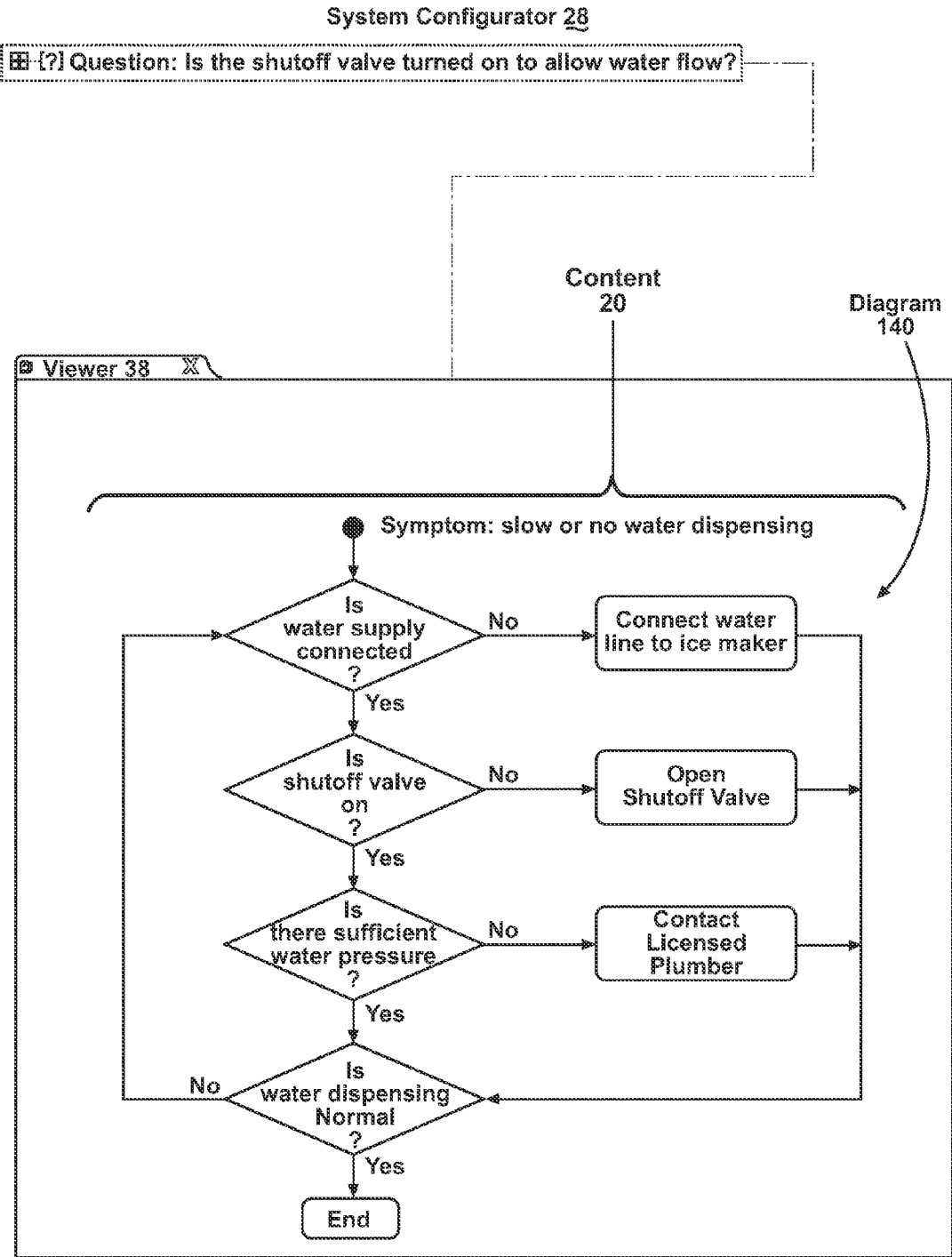

Fig. 14

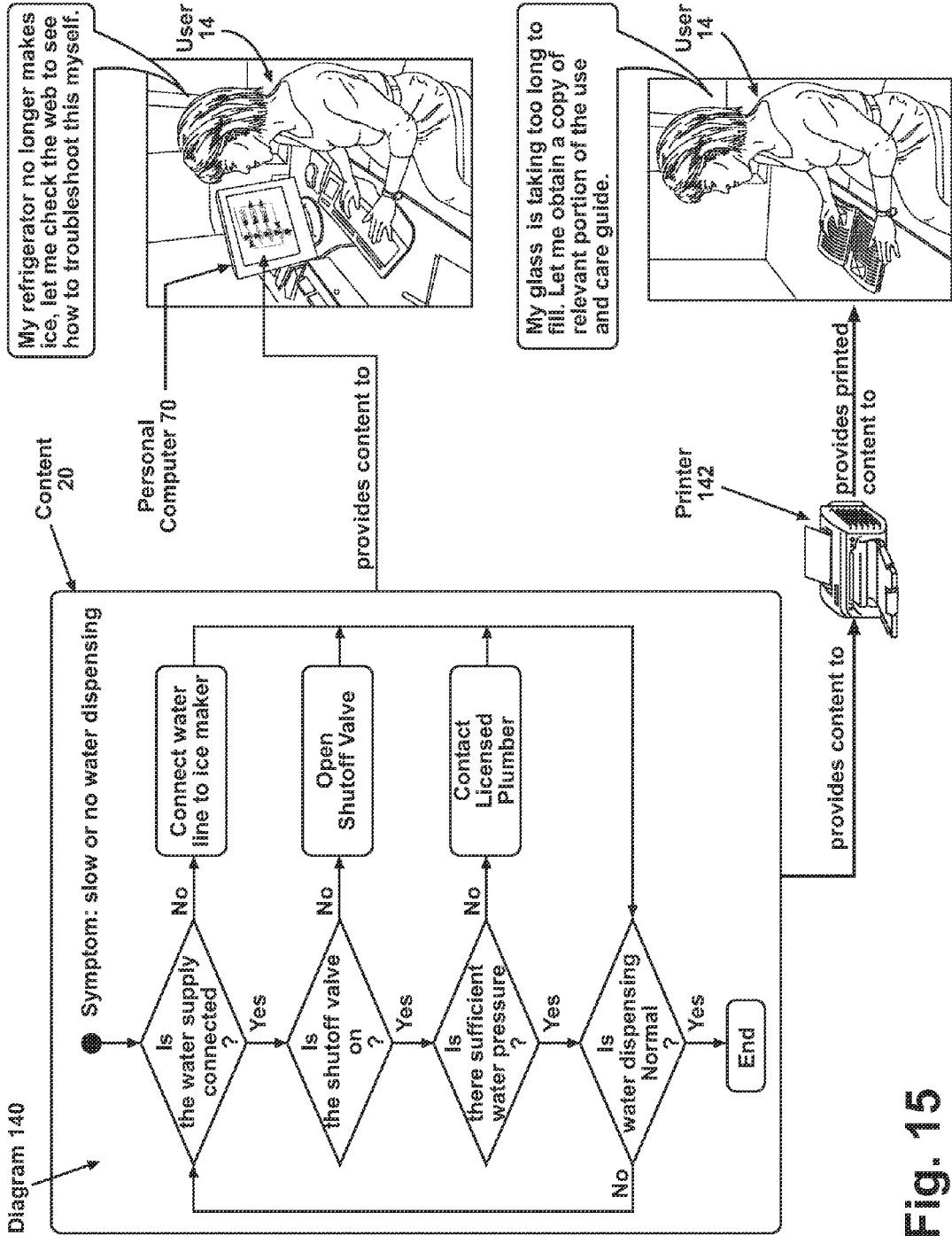

Fig. 15

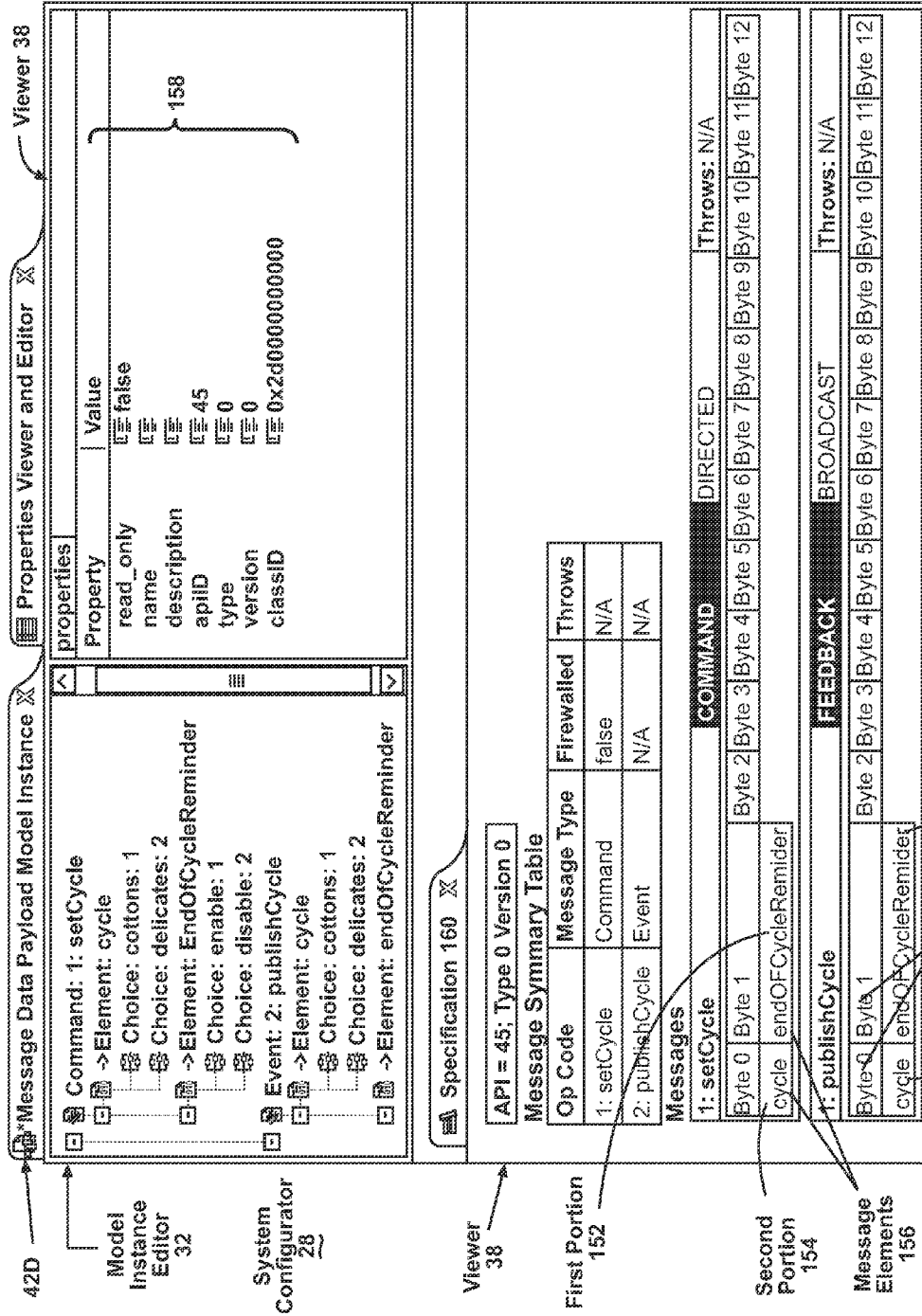

Fig. 16

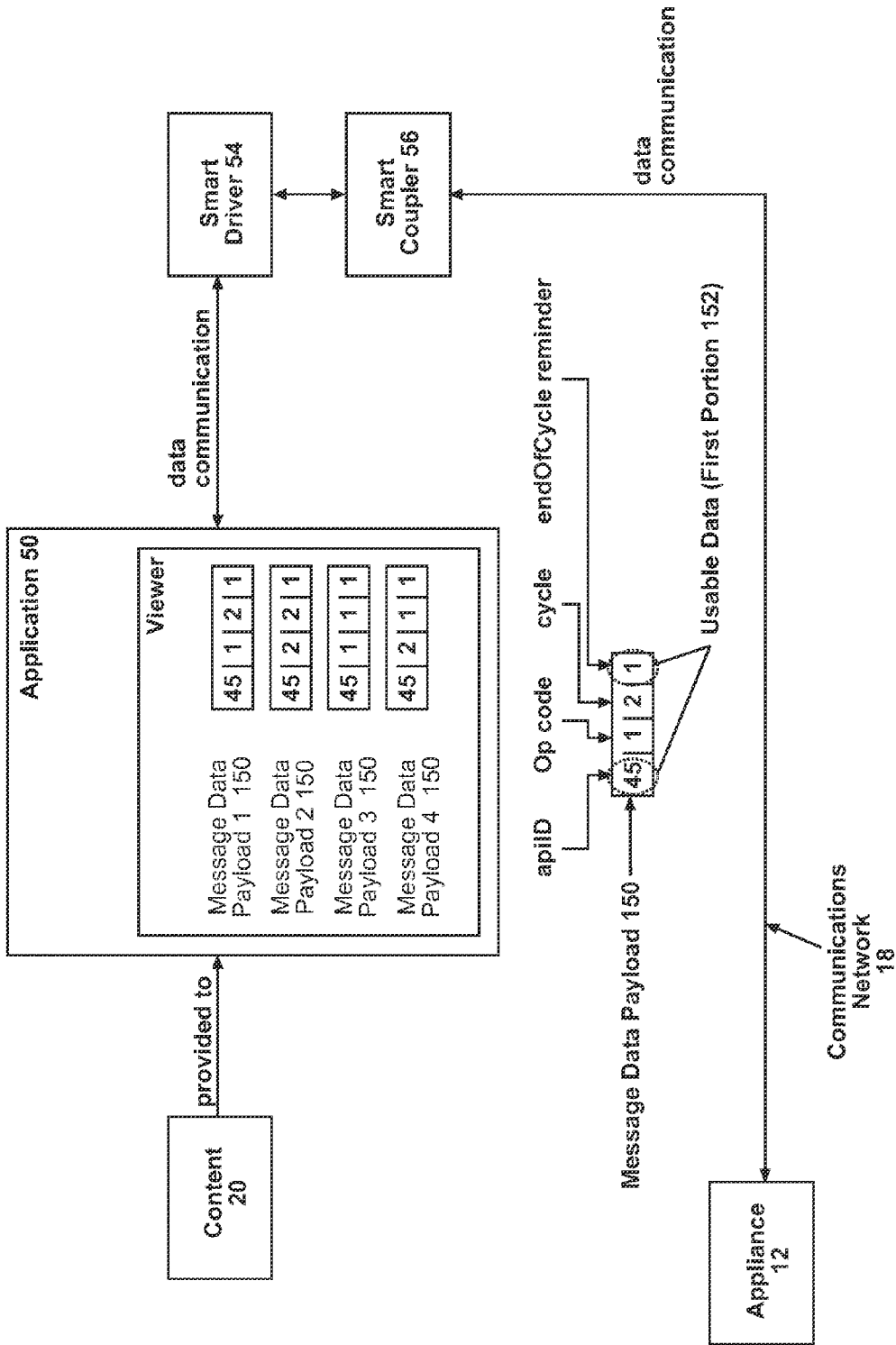

Fig. 17

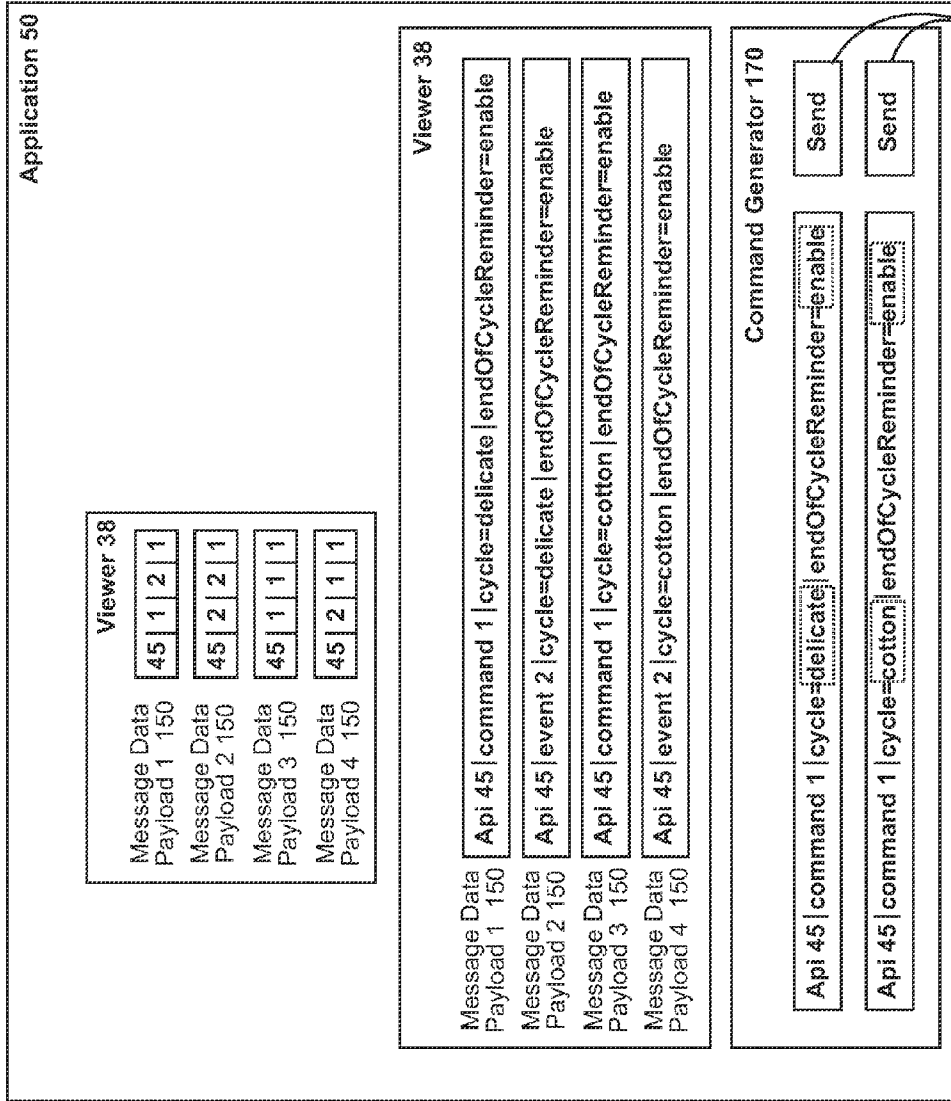

Fig. 18

122

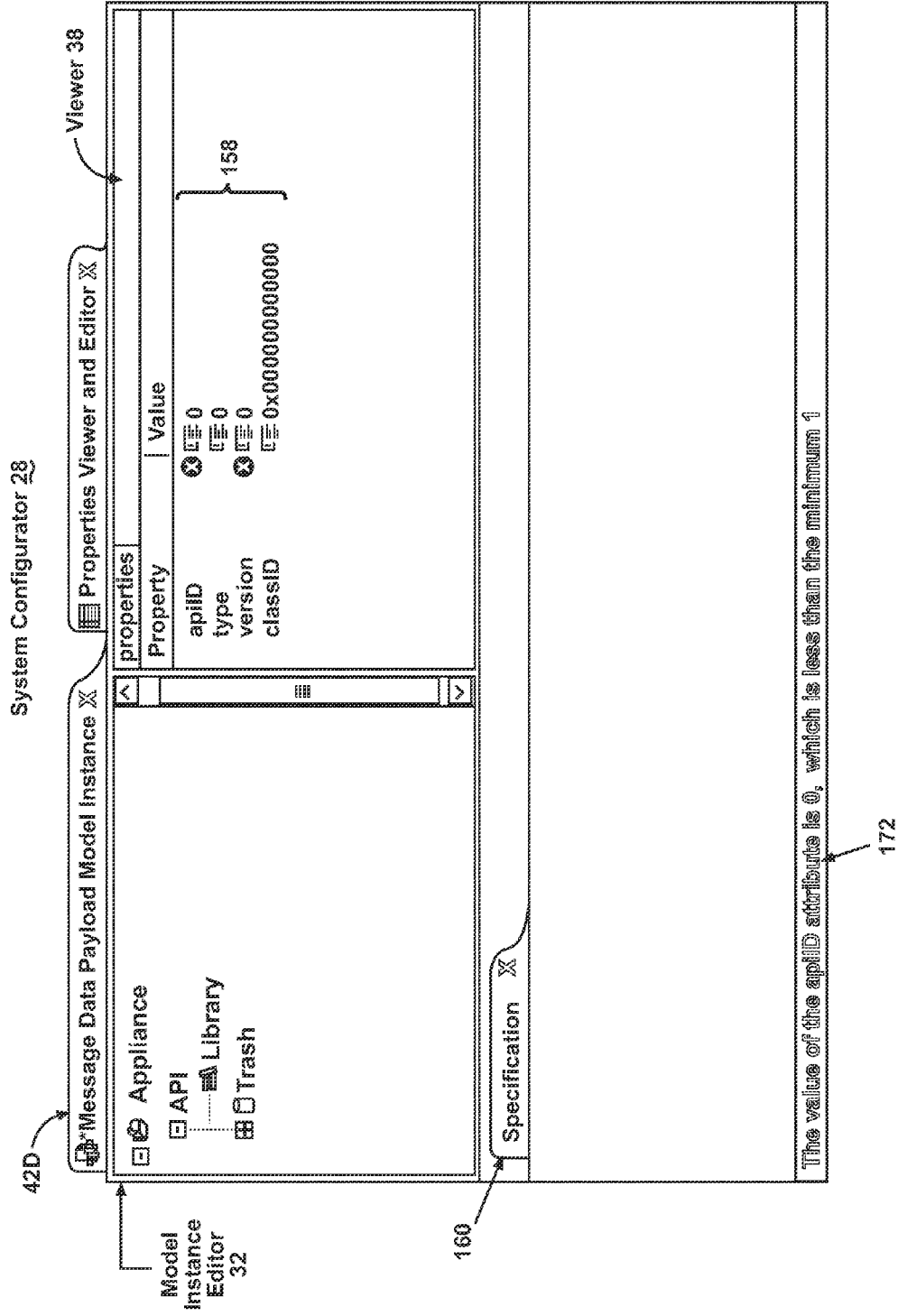

Fig. 19

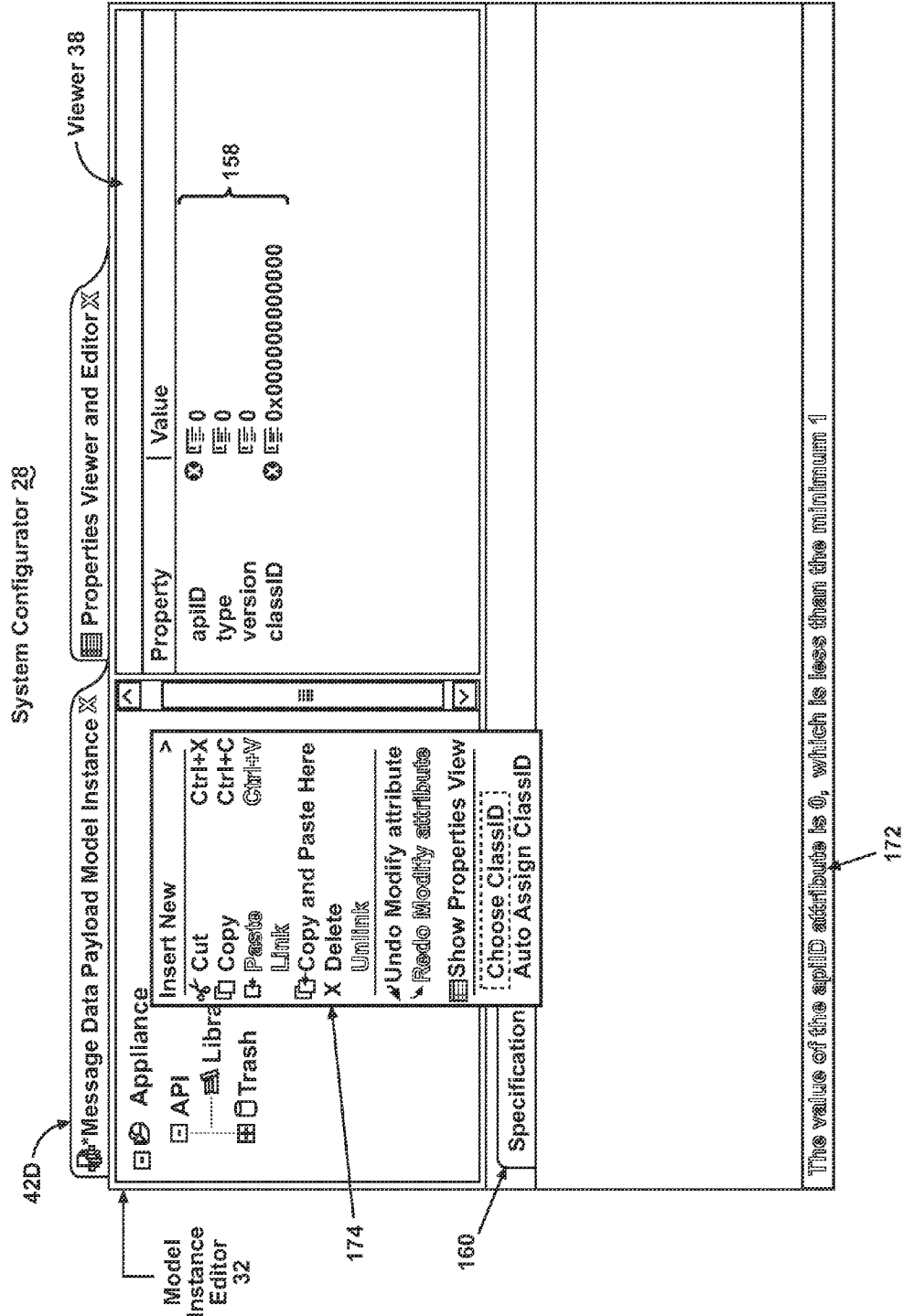

Fig. 20

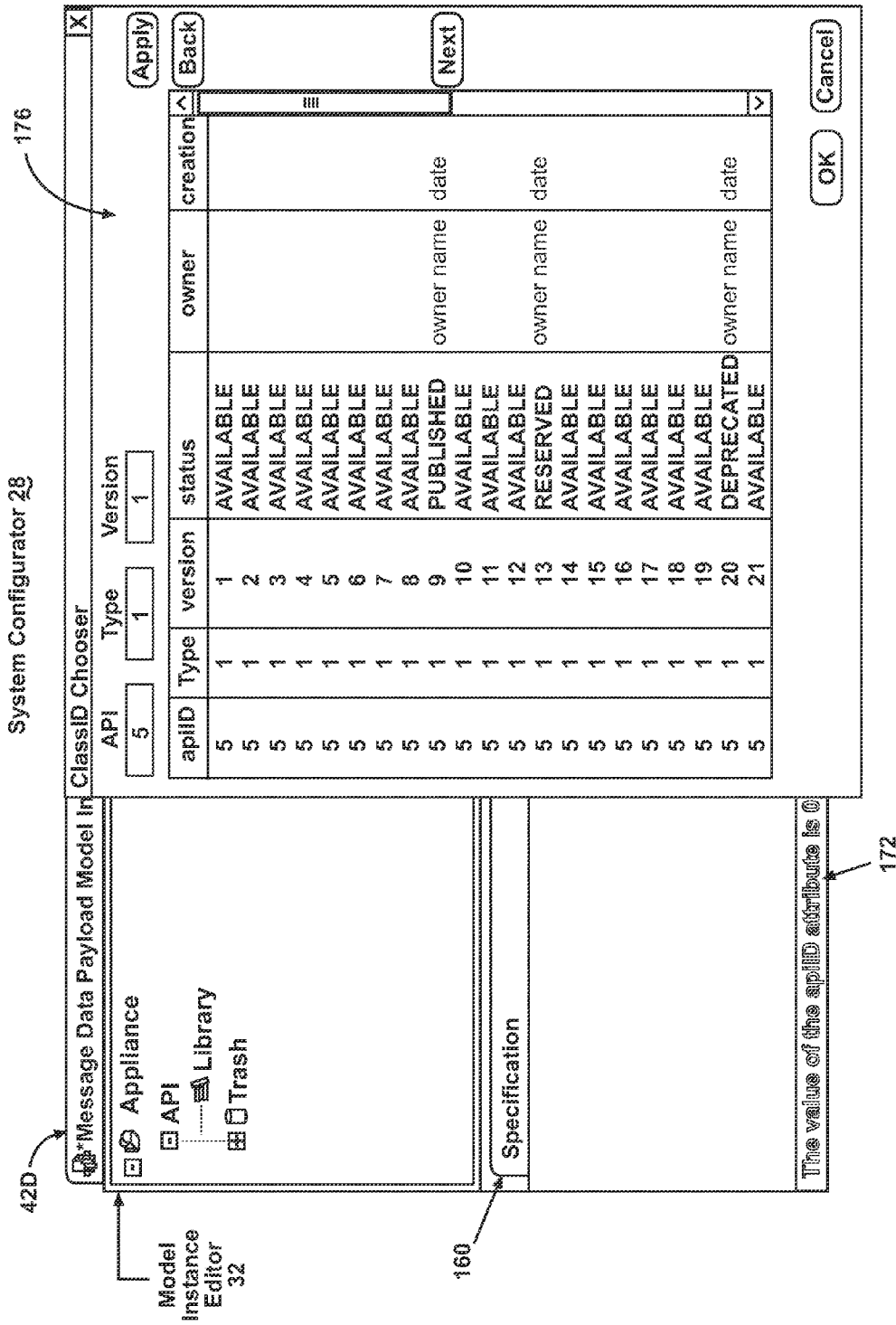

Fig. 21

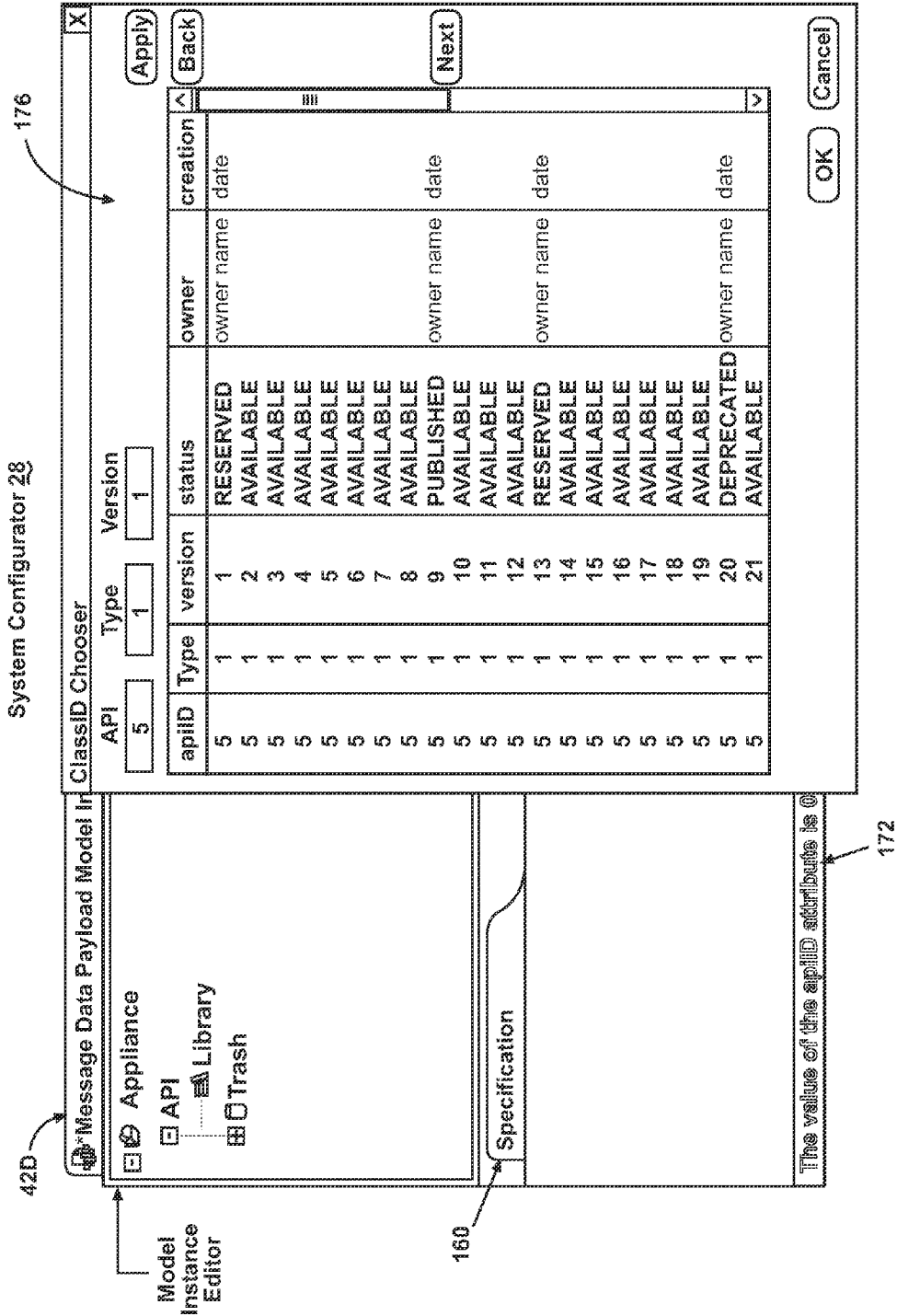

Fig. 22

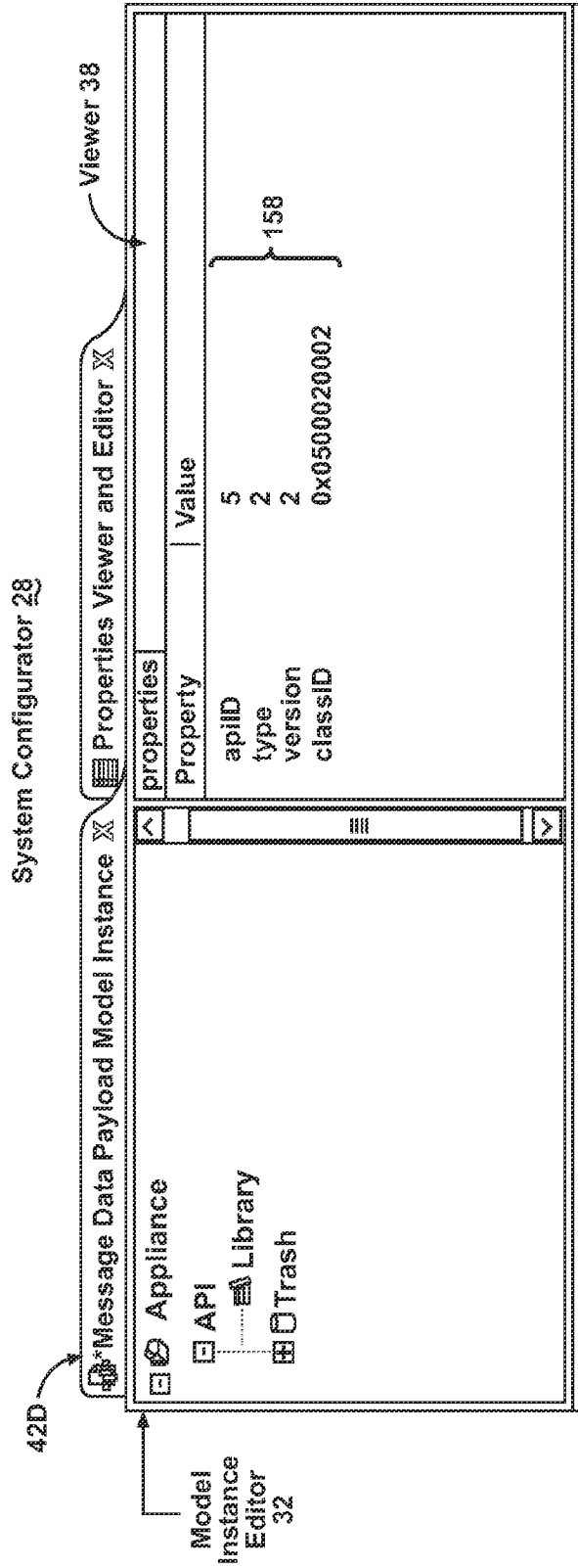

Fig. 23

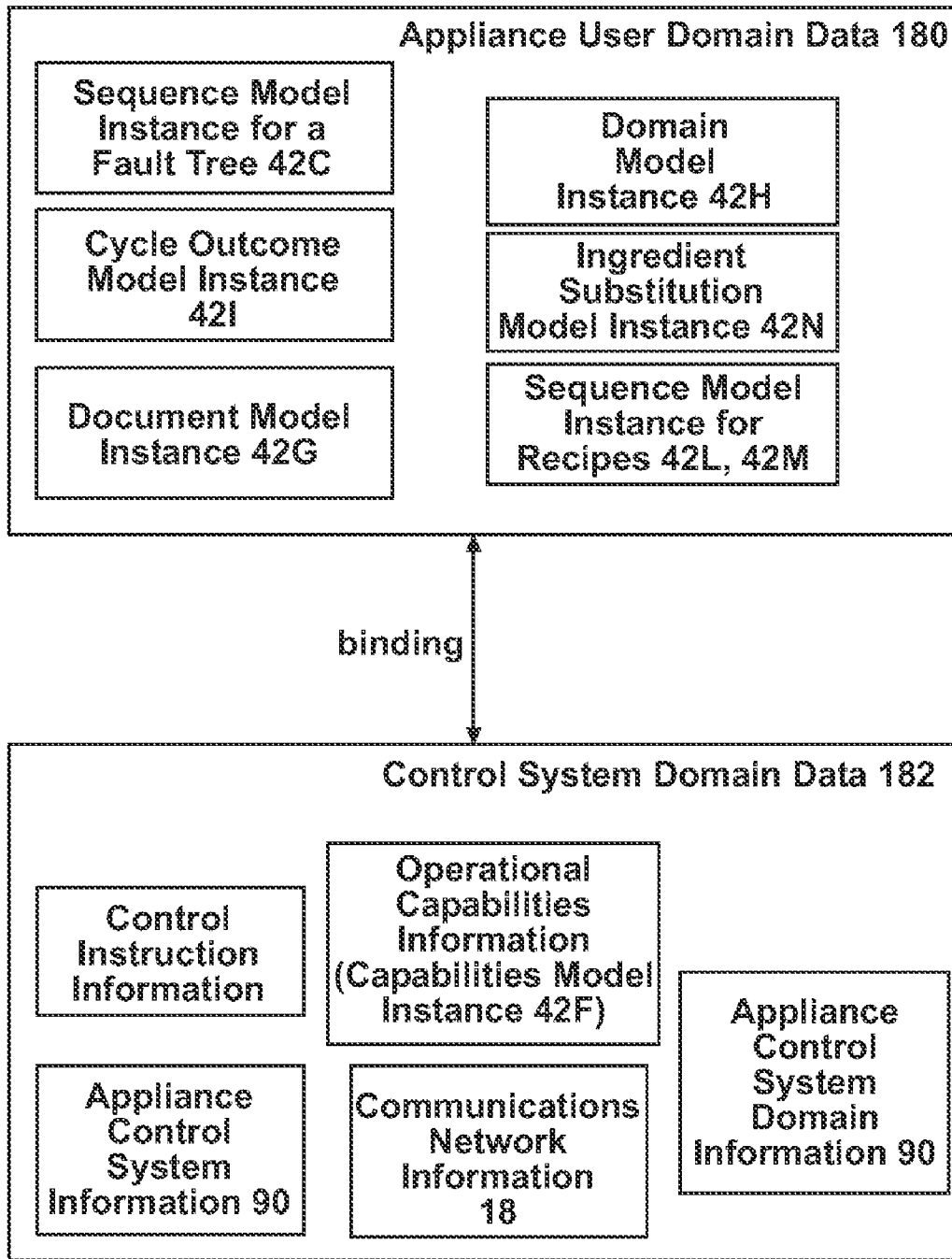

Fig. 24

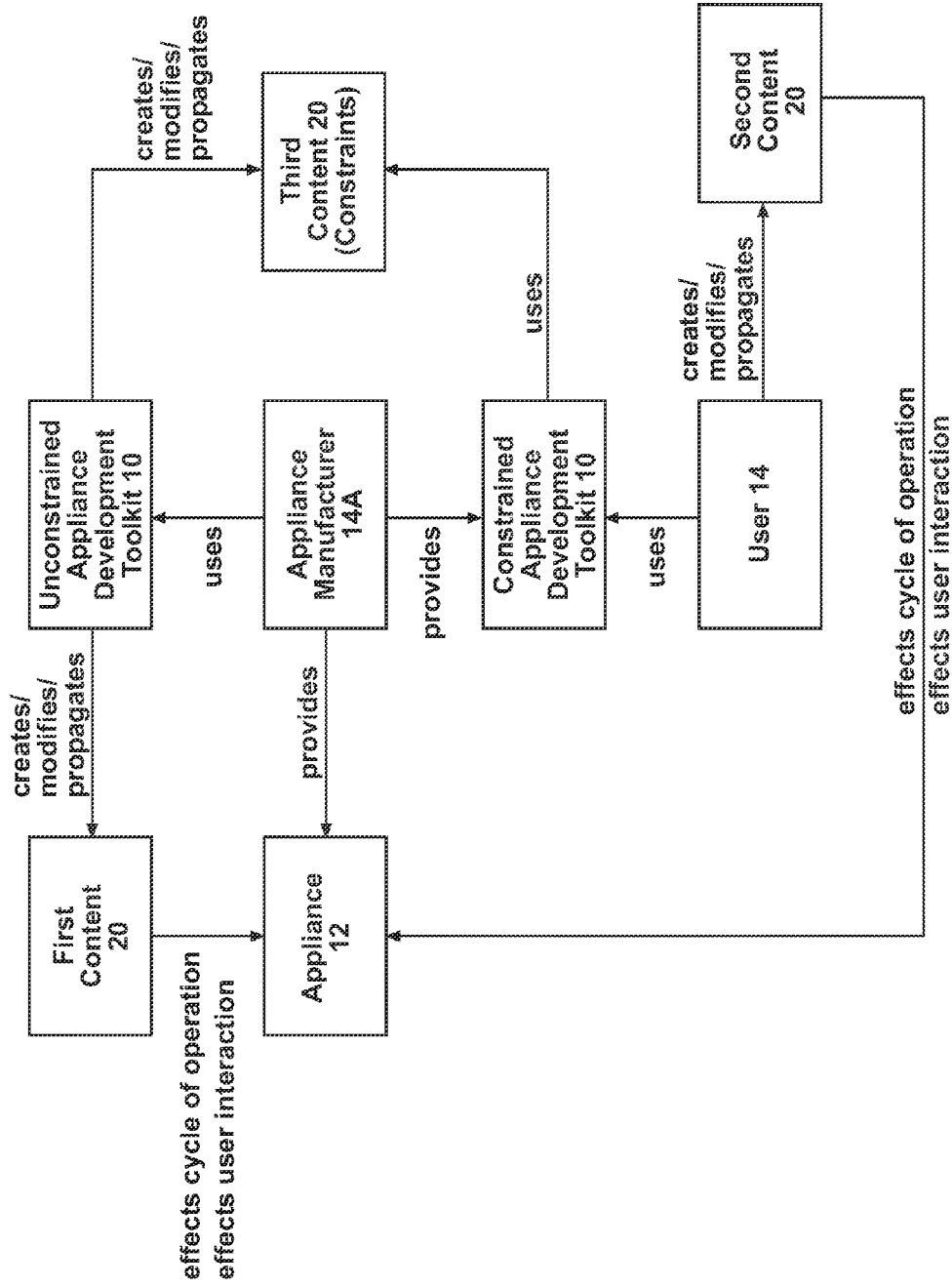

Fig. 25

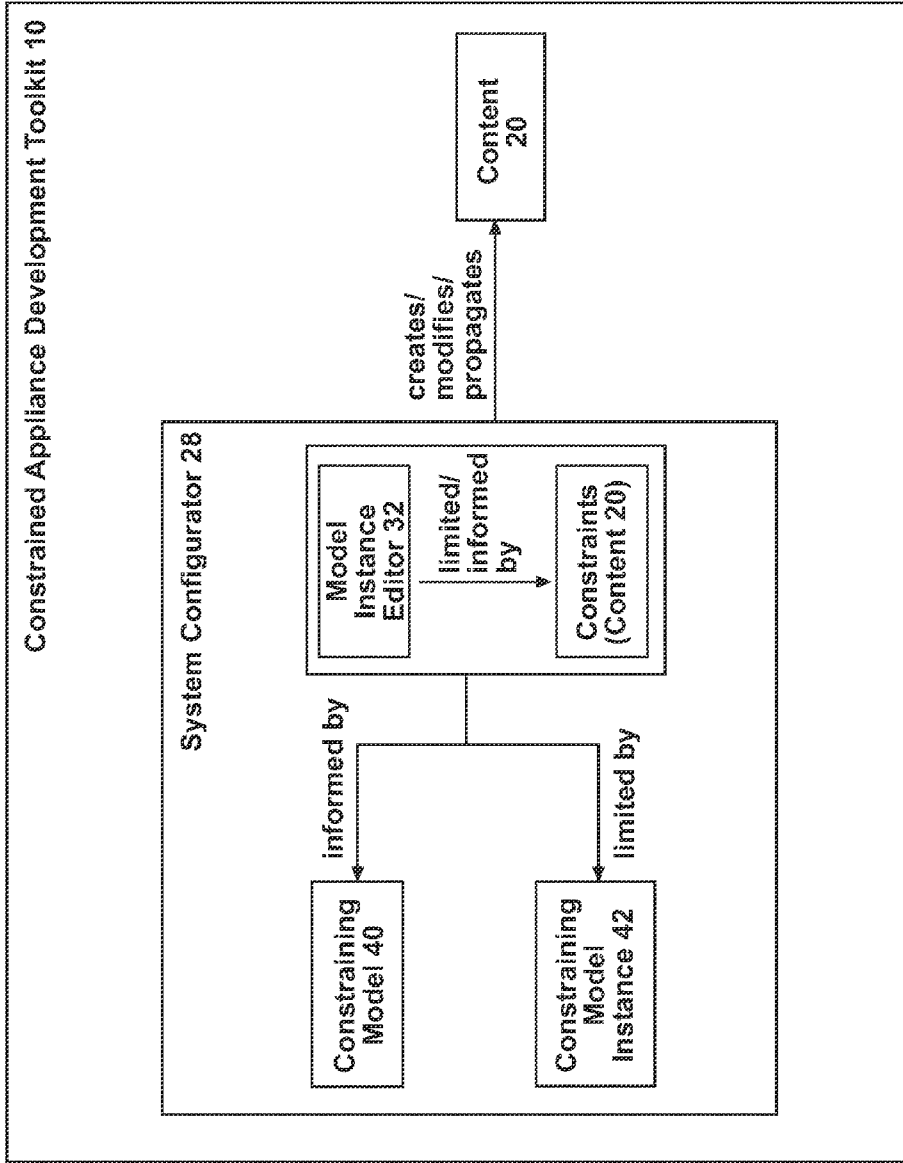

Fig. 26

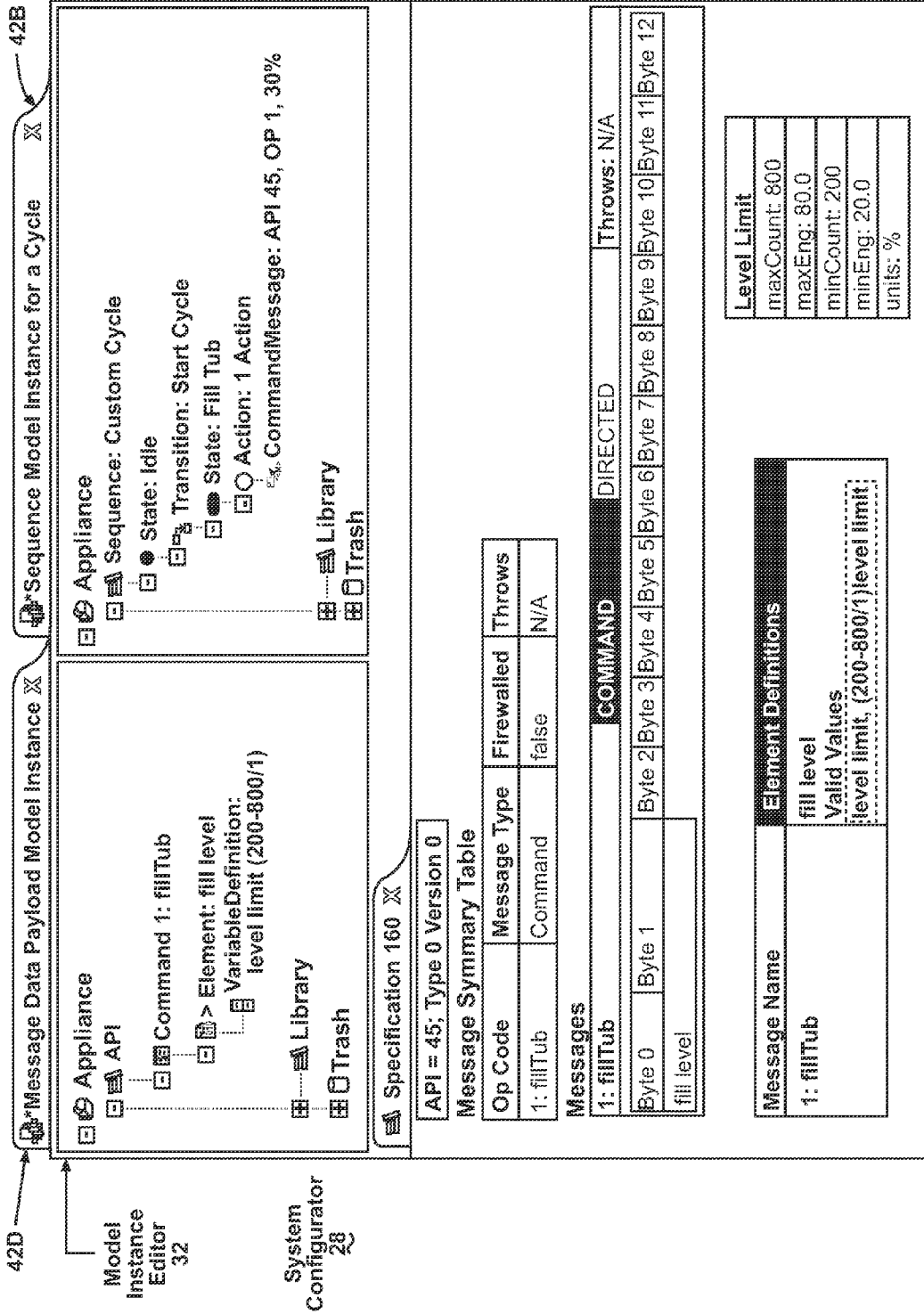

Fig. 27

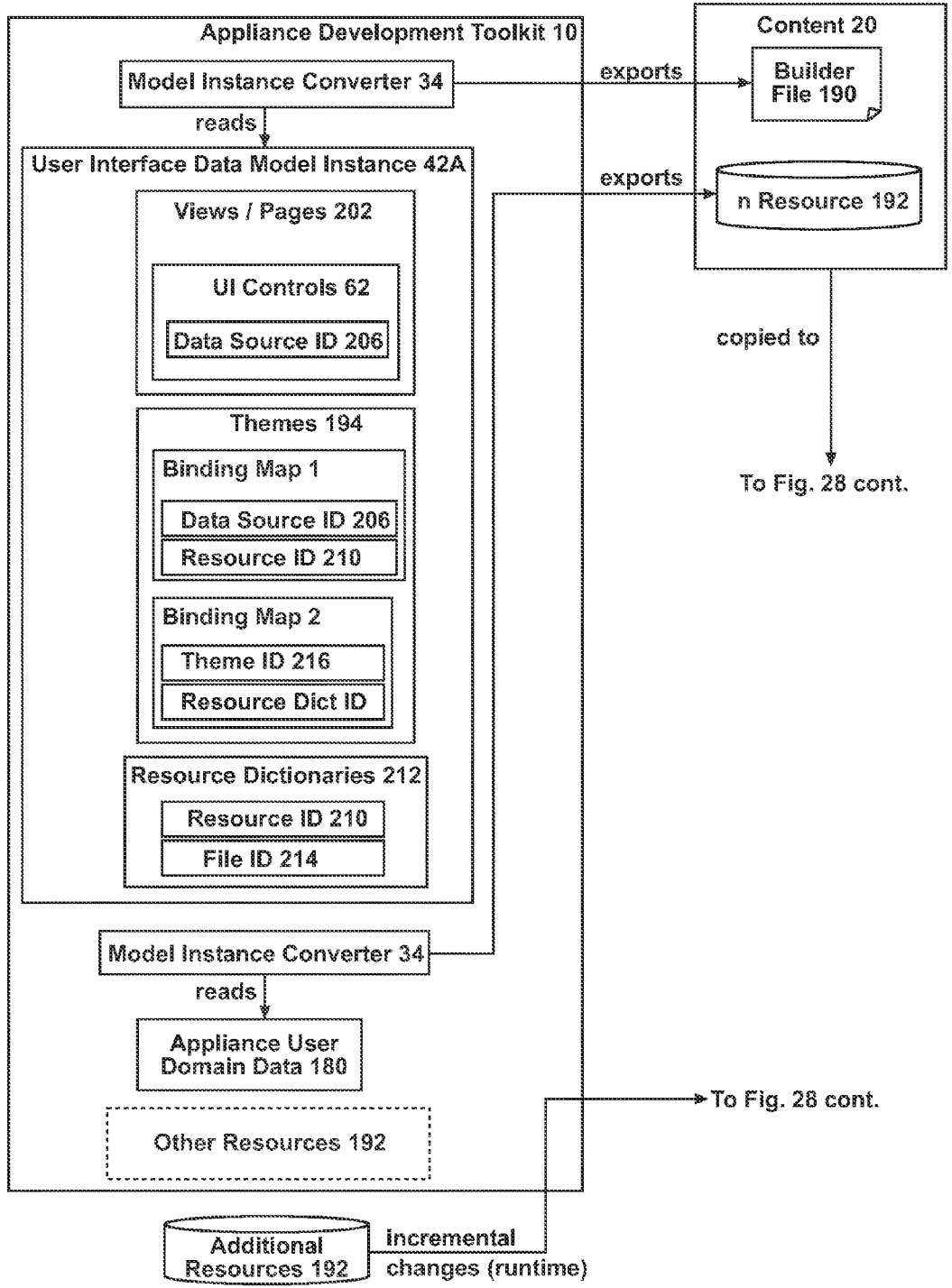

Fig. 28

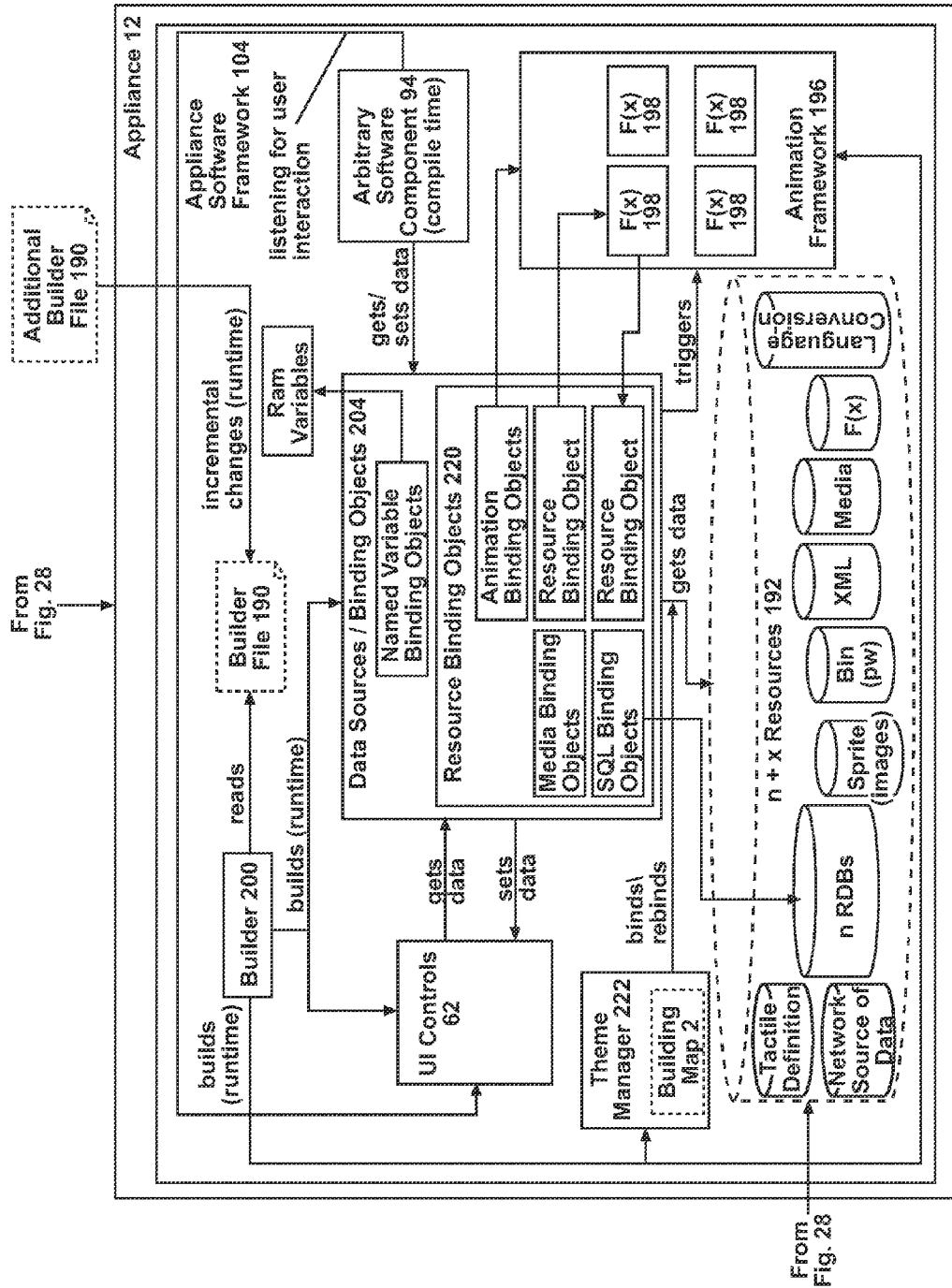

Fig. 28 cont.

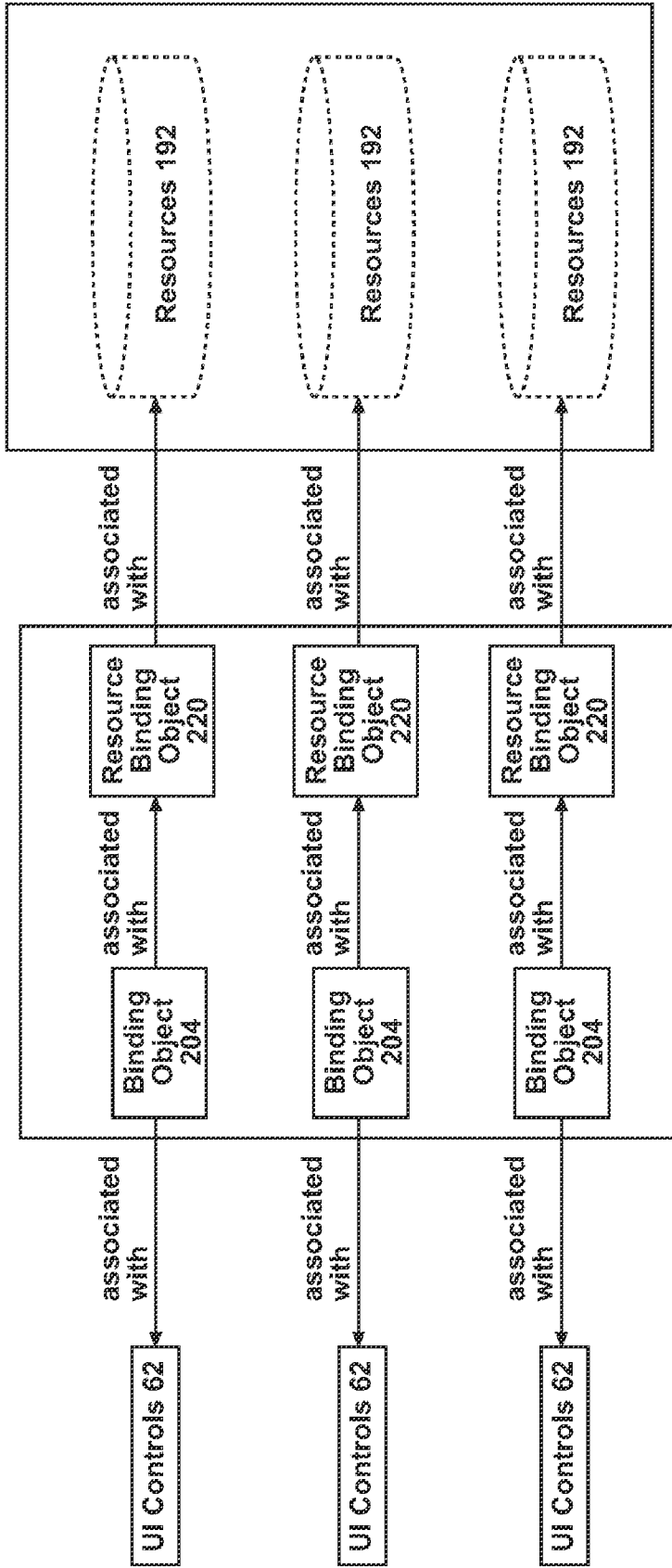

Fig. 29

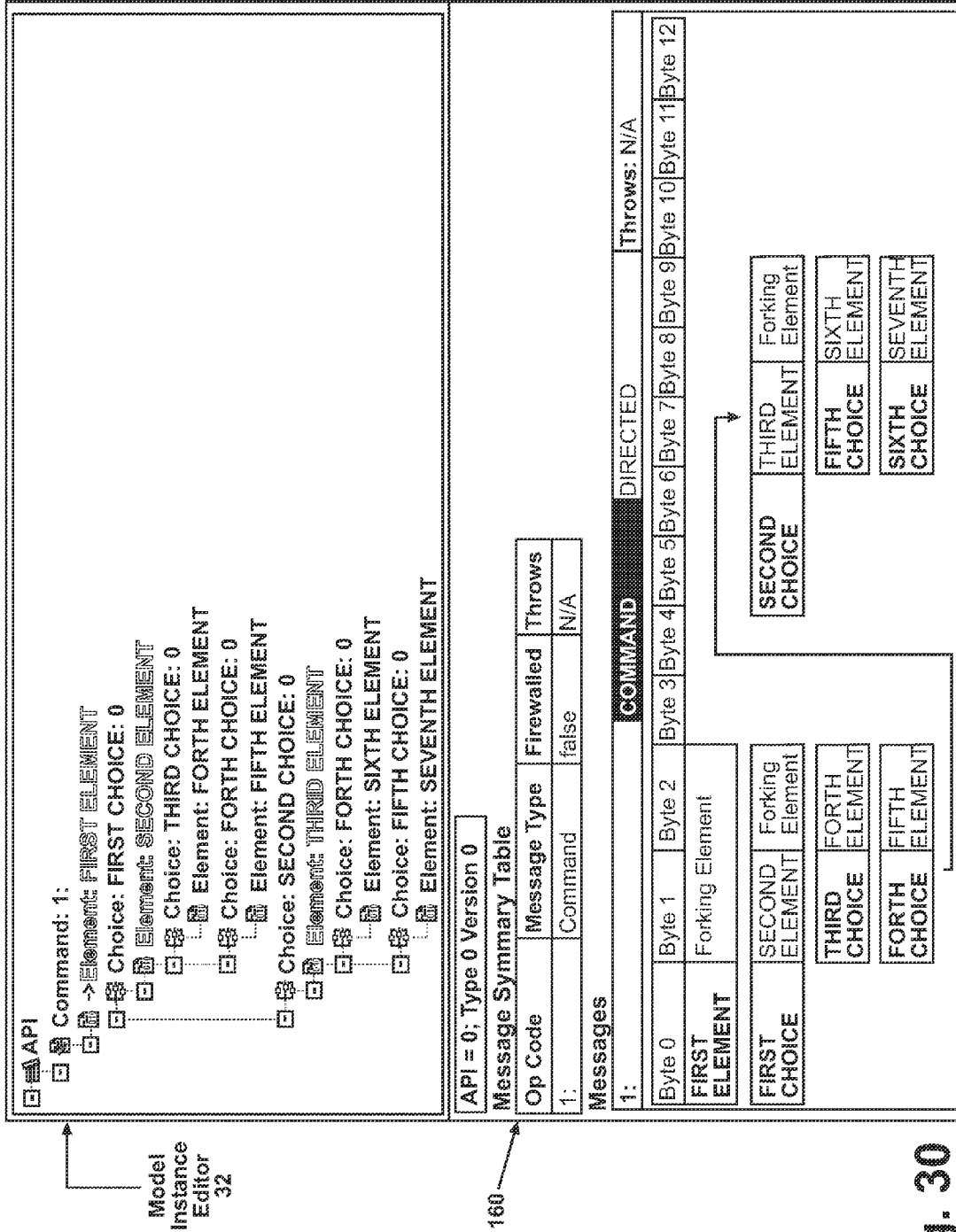

Fig. 30

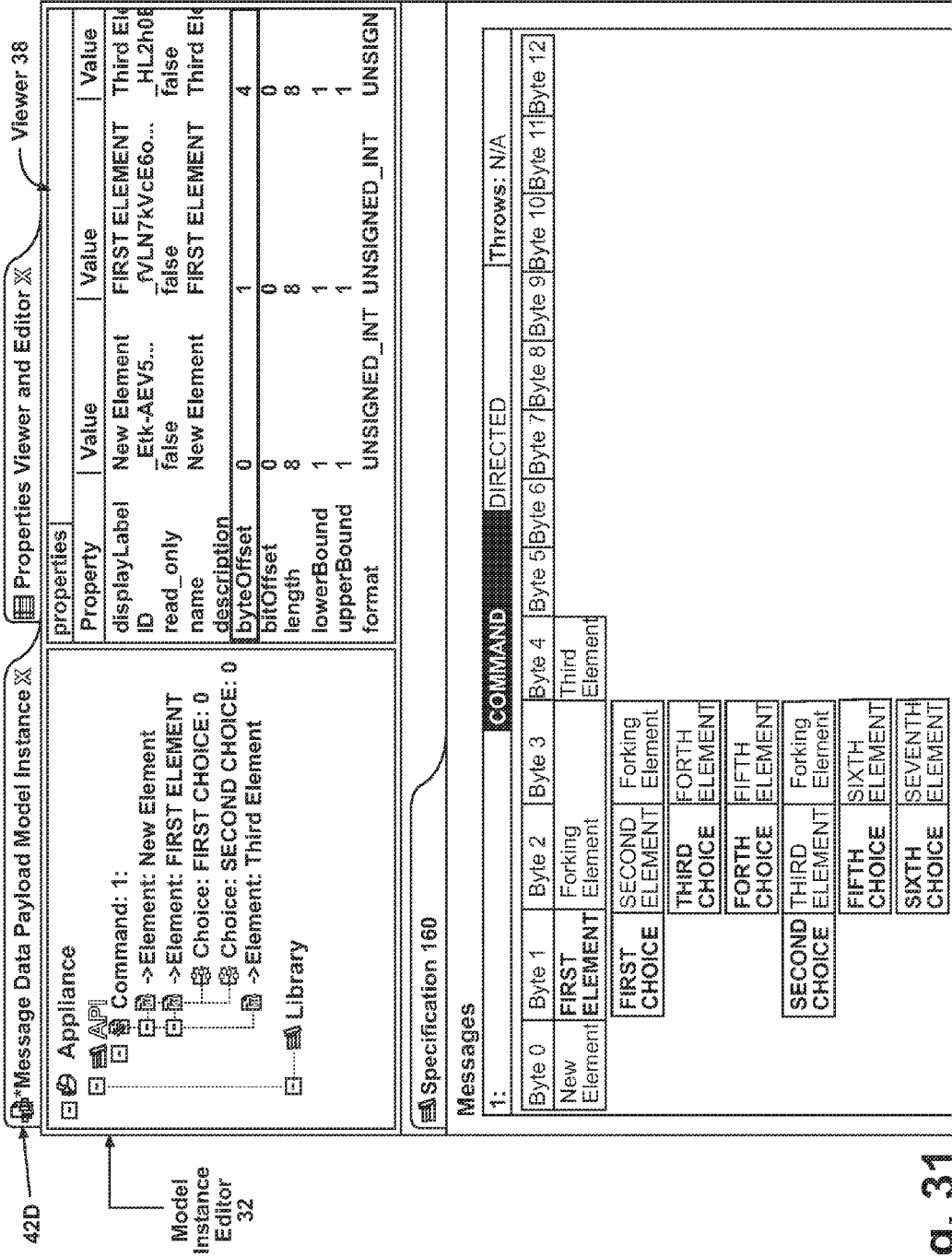

Fig. 31

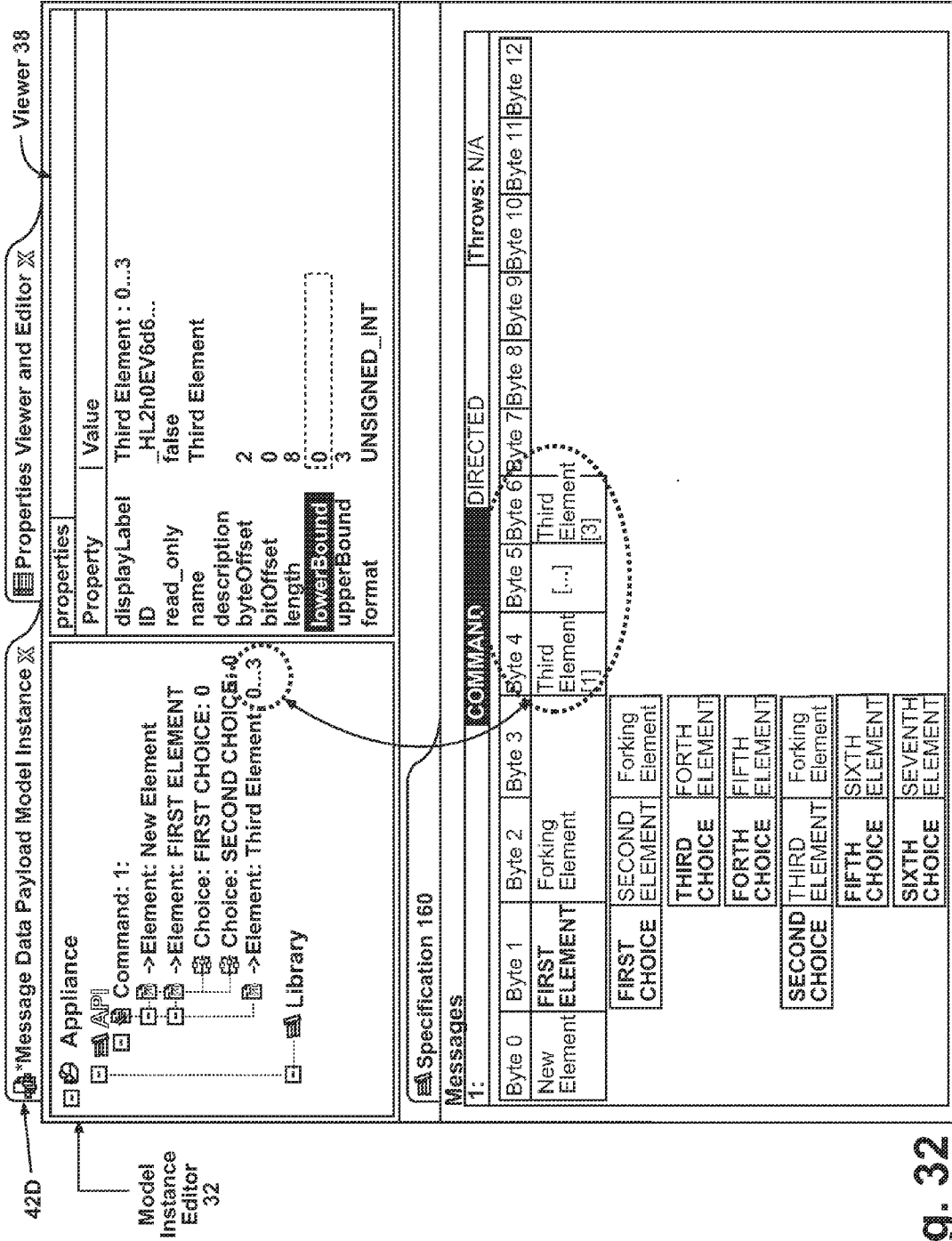

Fig. 32

42D → *Message Data Payload Model Instance X Properties Viewer and Editor X Viewer 38 Help X

Appliance

- API
- Command: 1
- Command: 2
- Element: →

Library

Property	Value
read_only	false
name	
description	
byteOffset	0
bitOffset	0
length	120
lowerBound	1
upperBound	1
format	UNSIGNED_INT

Related Topics

About Properties View Editor
Because we allow a byte to contain more than one message element it is possible to have a message element whose length does not fall on a byte boundary. For this reason, message element length is specified in bits (start counting at 1).

Dynamic Help
Search results for "Properties View"

Specification 160

Messages

2: COMMAND DIRECTED Throws: N/A

Byte 0	Byte 1	Byte 2	Byte 3	Byte 4	Byte 5	Byte 6	Byte 7	Byte 8	Byte 9	Byte 10	Byte 11	Byte 12
Byte 13	Byte 14	Byte 15	Byte 16	Byte 17	Byte 18	Byte 19	Byte 20	Byte 21	Byte 22	Byte 23	Byte 24	Byte 25

Model Instance Editor 32

Fig. 33

Message Data Payload Model Instance X Properties Viewer and Editor X Viewer 38 Help X

42D

Model Instance Editor 32

Appliance

- API
 - Command: 1
 - Command: 2
 - Element: Library
 - Element_Library
 - Variable_Library
 - ReasonCode_Library

Property	Value
read_only	false
name	
description	
byteOffset	0
bitOffset	0
length	9
lowerBound	1
upperBound	1
format	UNSIGNED_INT

Related Topics

About Model Instance Editor

Often, a message contains data payload many parameters within the payload. Each parameter has its own meaning, and even its own validation. Creating a message data payload from multiple message elements allows the developer to specify in great detail all of the information associated with each element of a message data payload.

Specification 160

Messages

2: COMMAND DIRECTED Throws: N/A

Byte 0	Byte 1	Byte 2	Byte 3	Byte 4	Byte 5	Byte 6	Byte 7	Byte 8	Byte 9	Byte 10	Byte 11	Byte 12
0	1	2	3	4	5	6	7	0				

Fig. 34

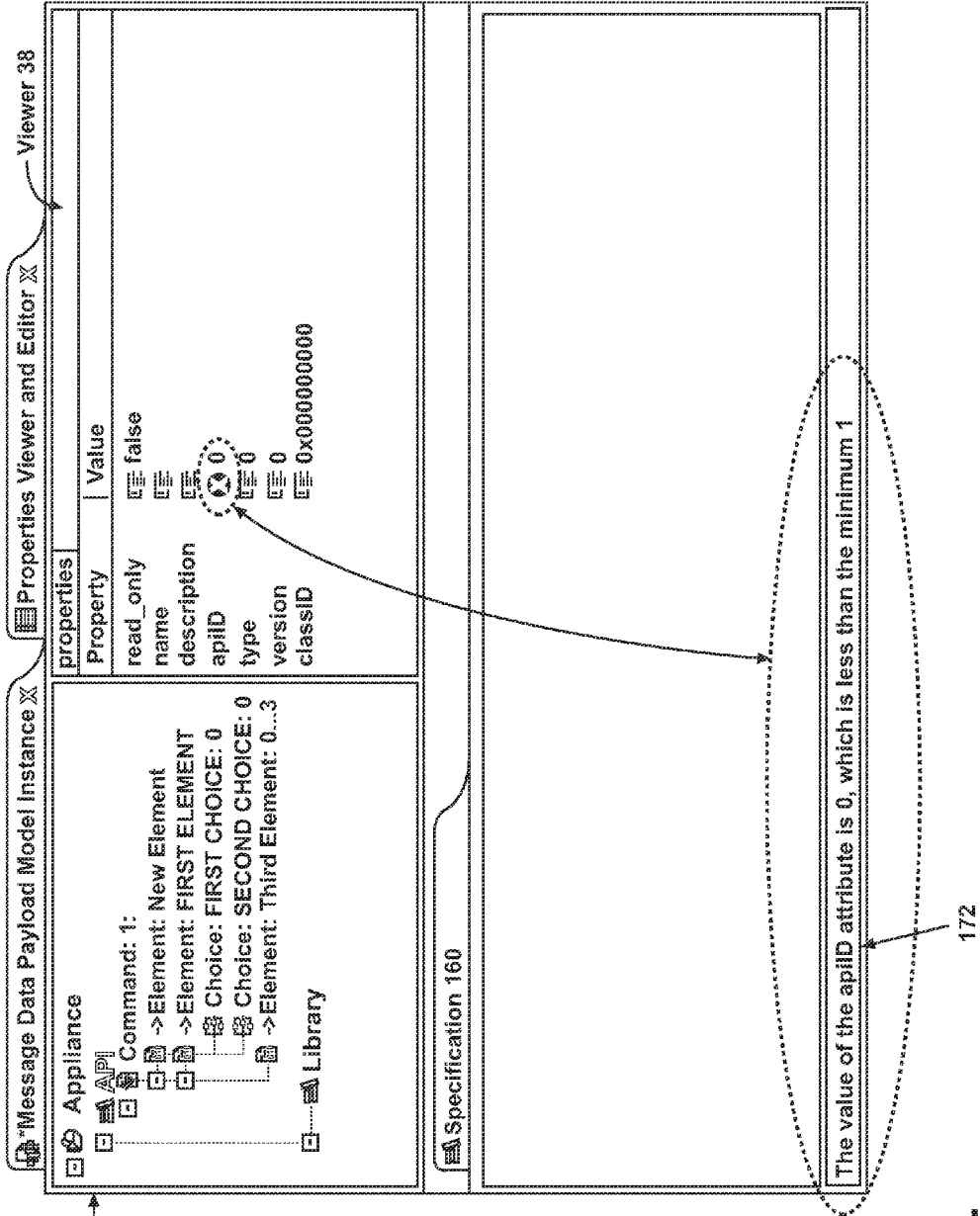

Fig. 35

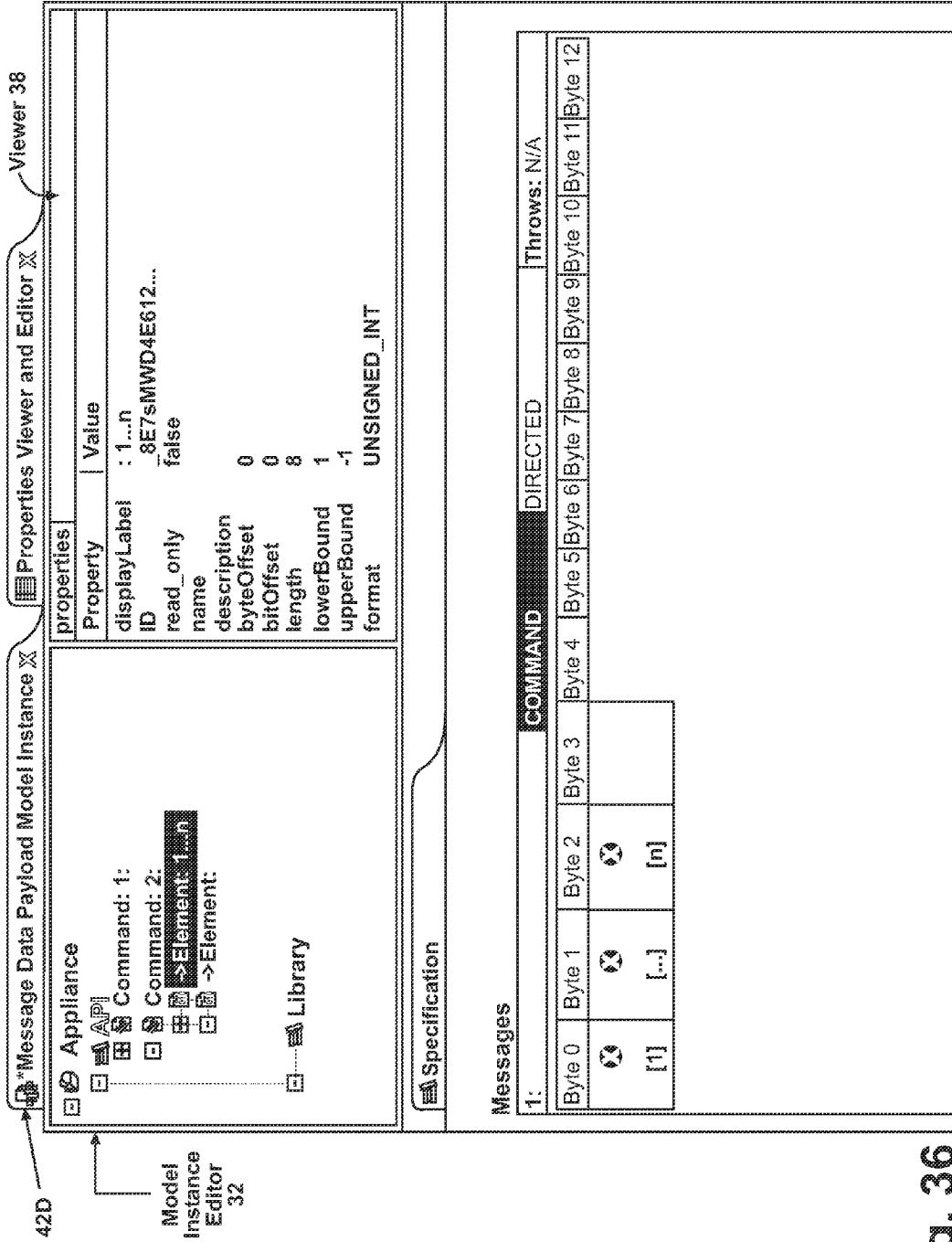

Fig. 36

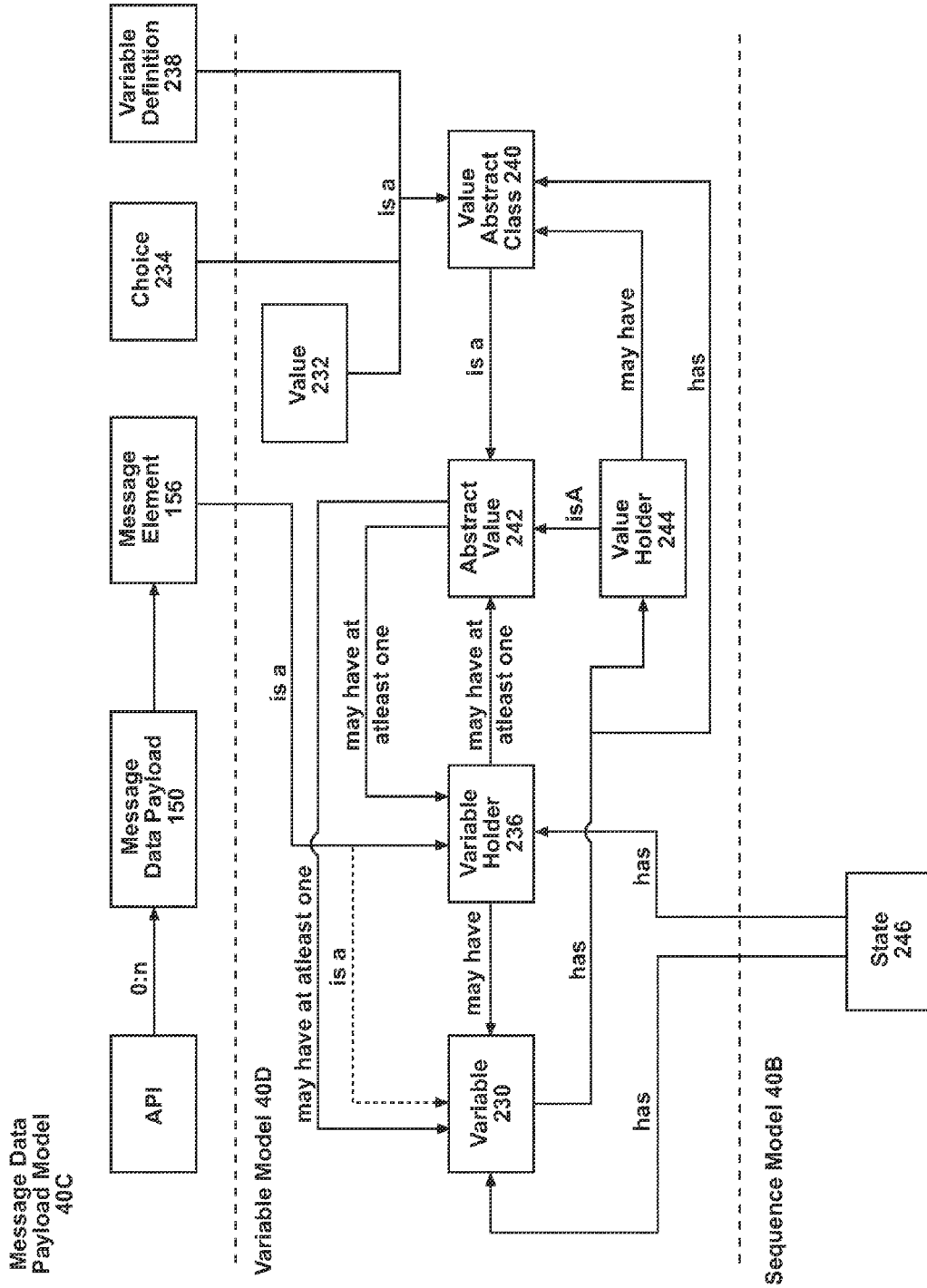

Fig. 37

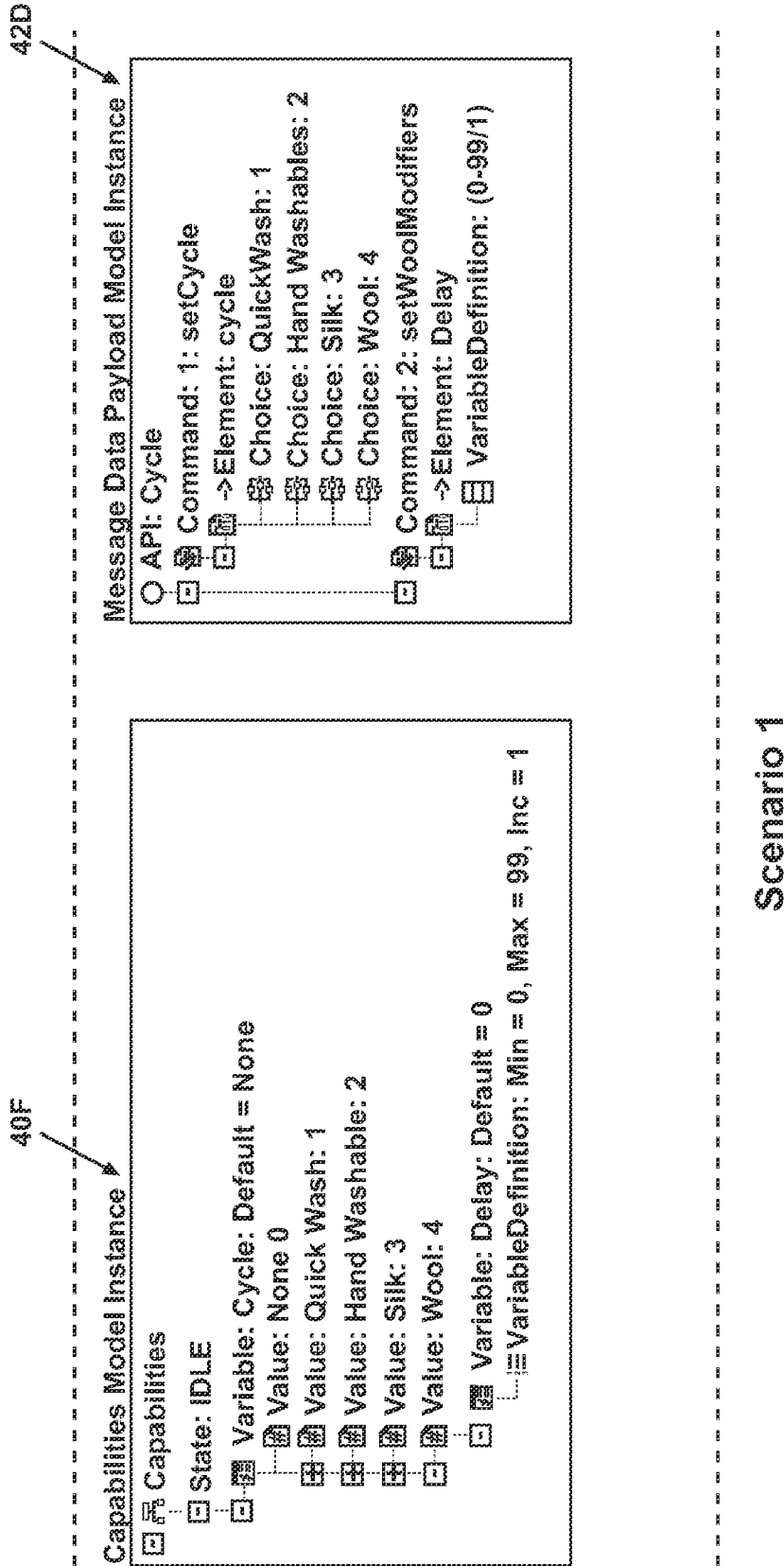
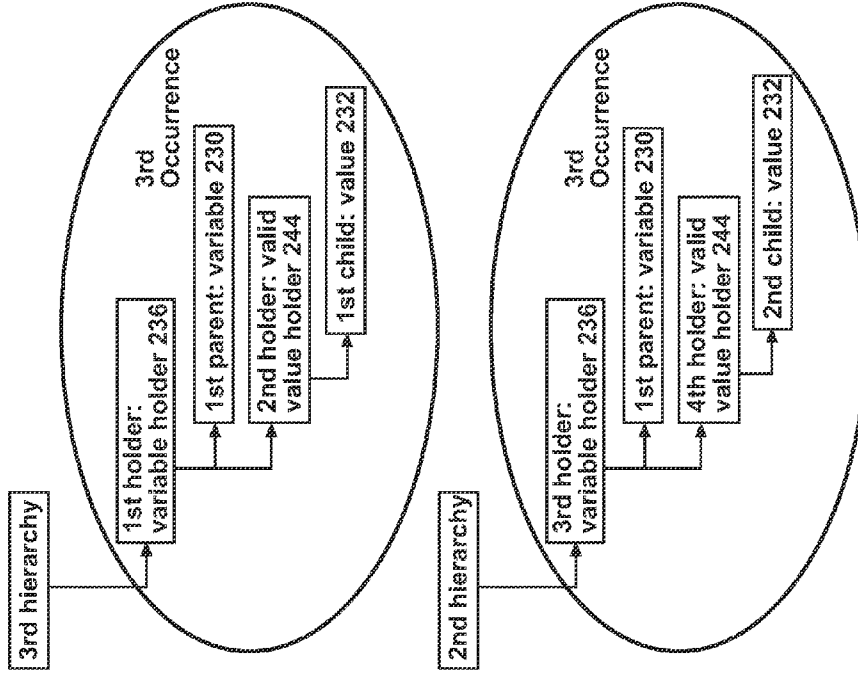
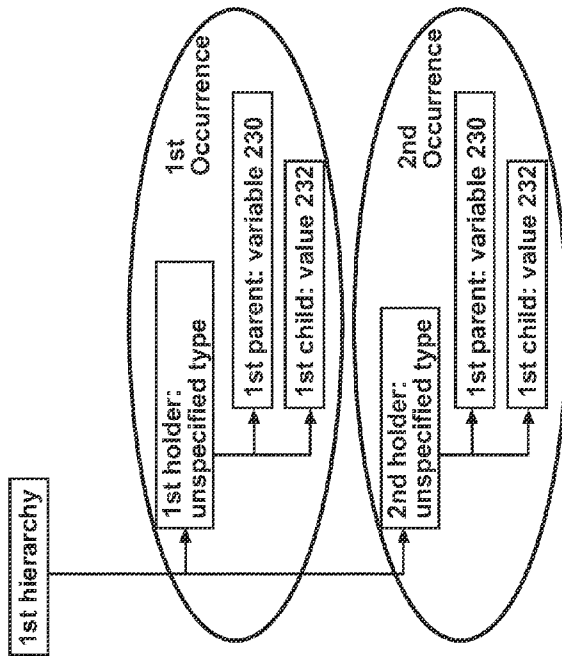

Fig. 38



Scenario 3

Fig. 40



Scenario 2

Fig. 39

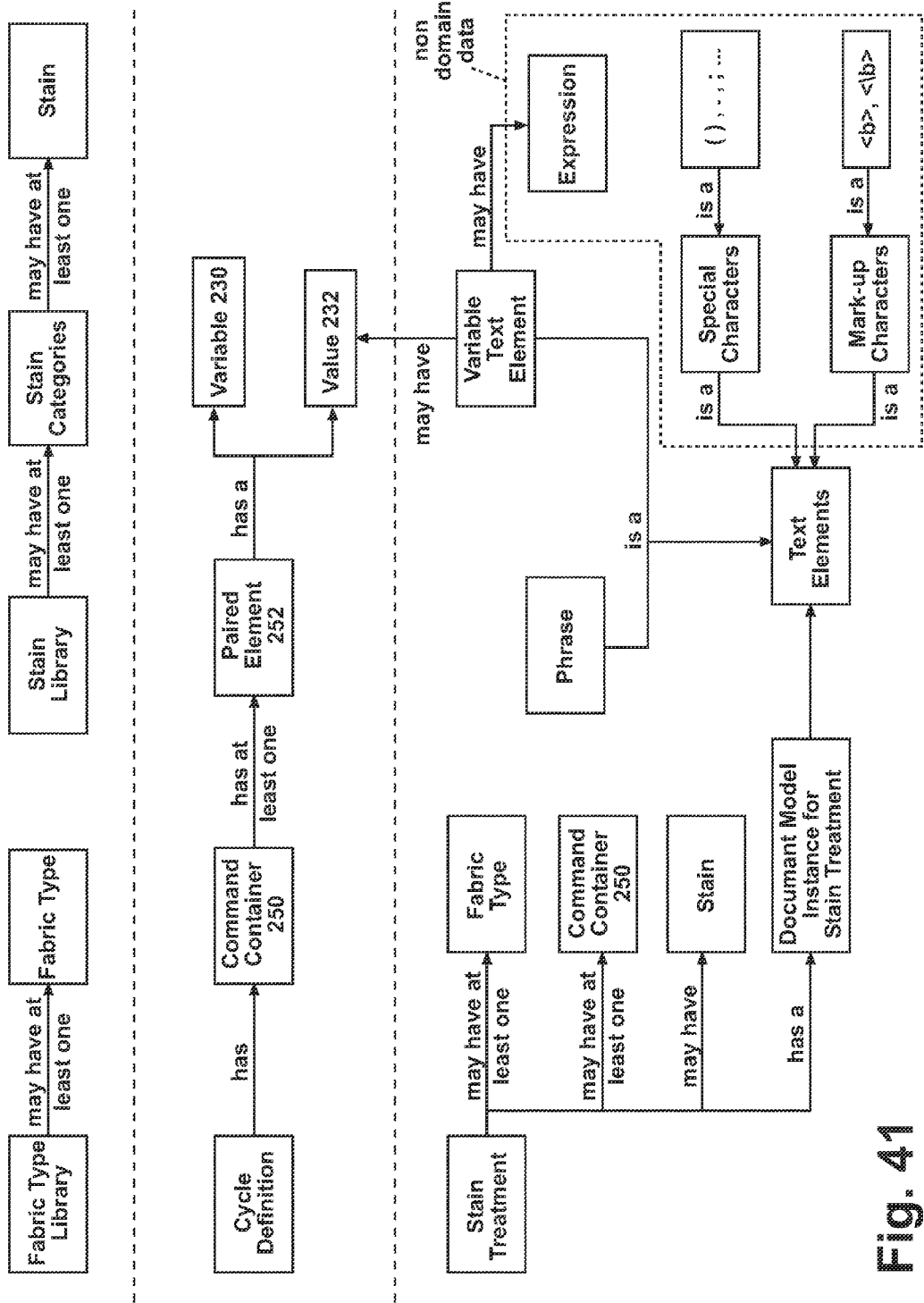

Fig. 41

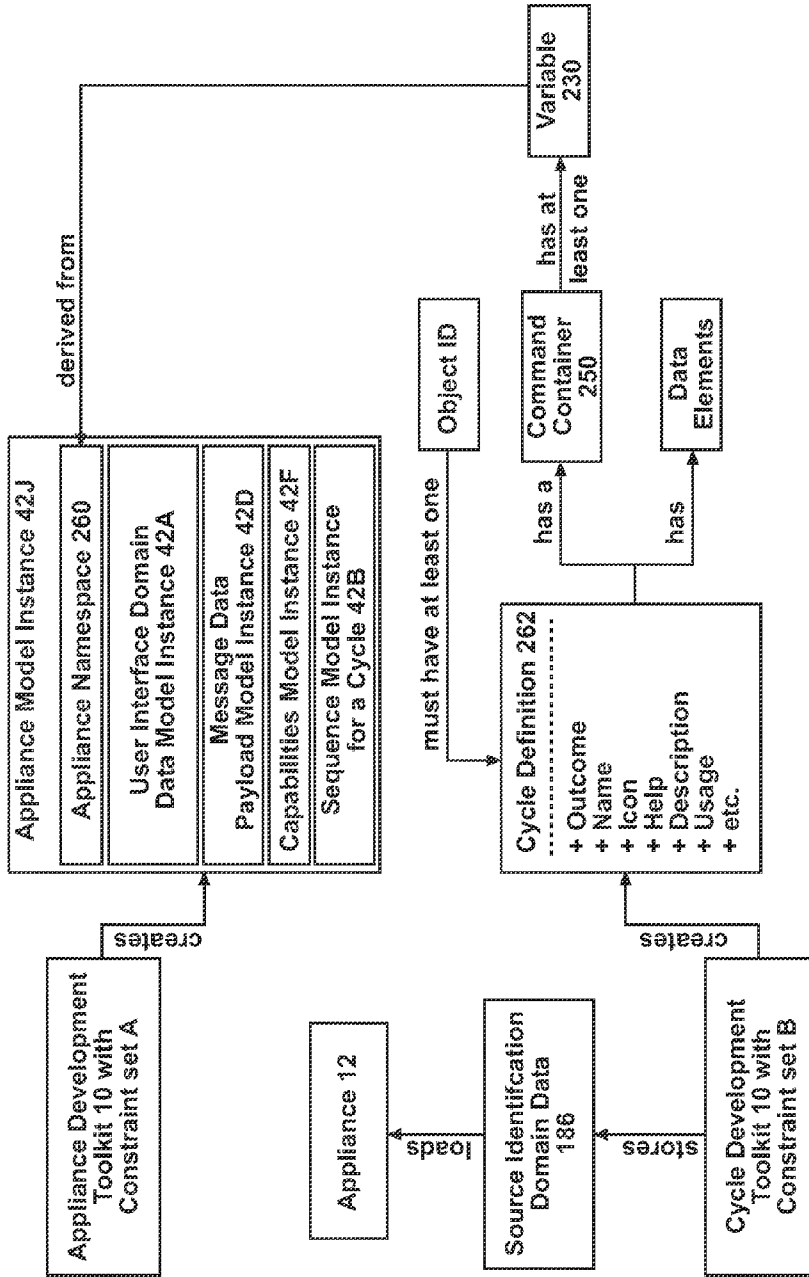
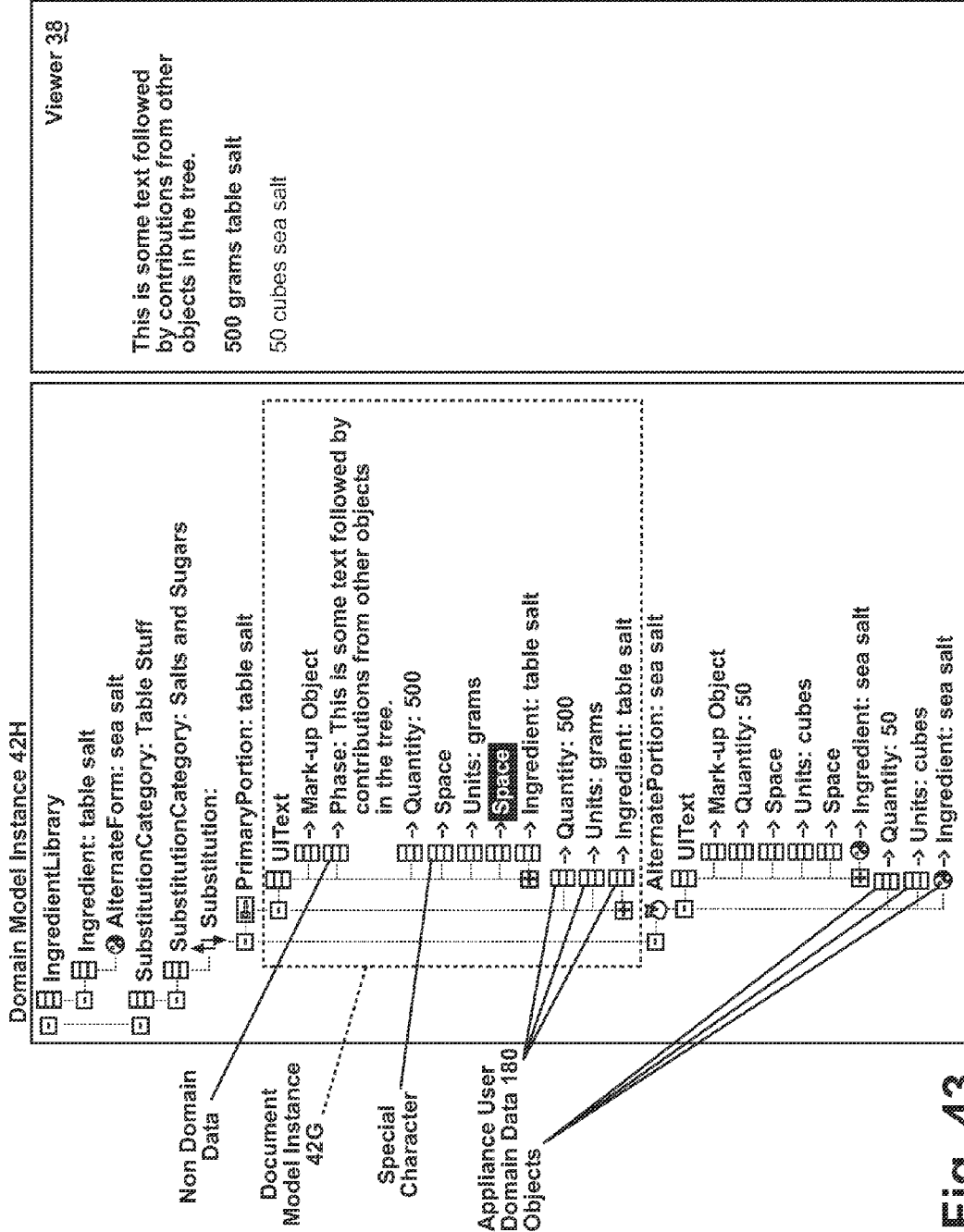

Fig. 42



Viewer 38

This is some text followed by contributions from other objects in the tree.

500 grams table salt
50 cubes sea salt

Fig. 43

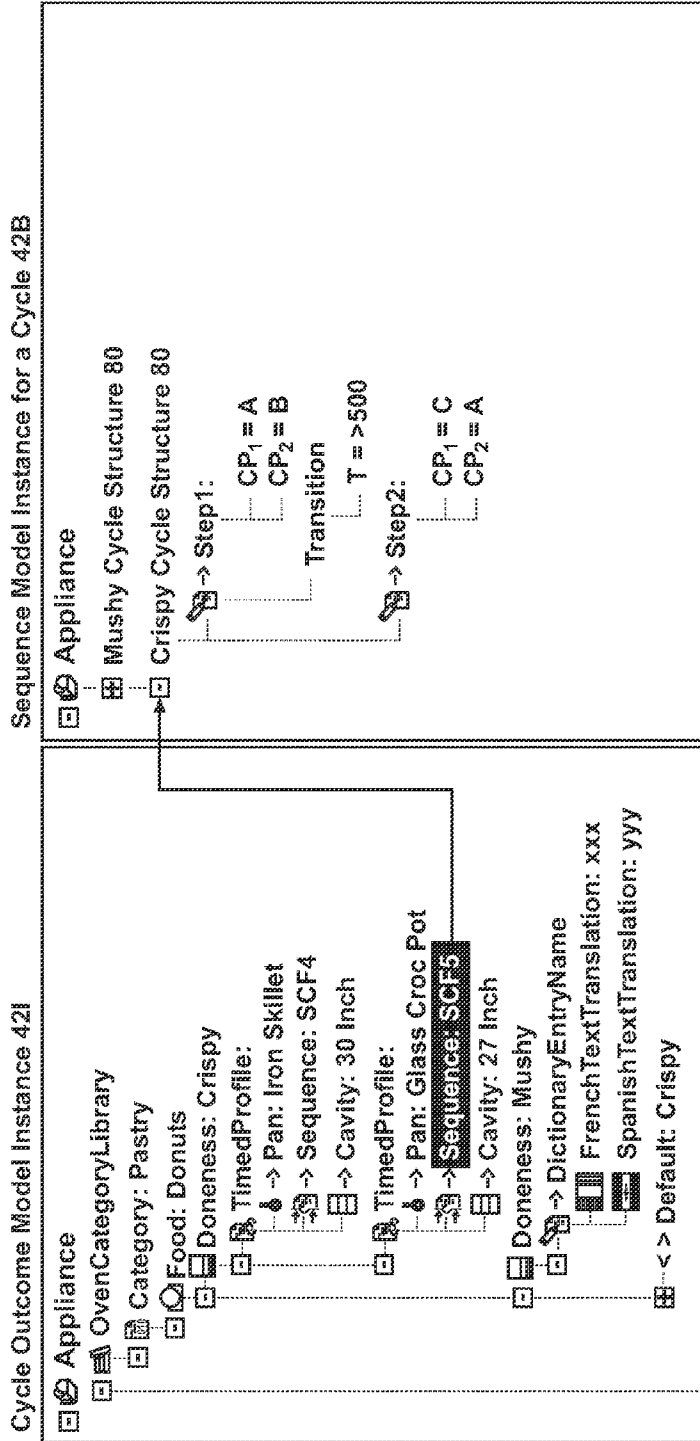

Fig. 44

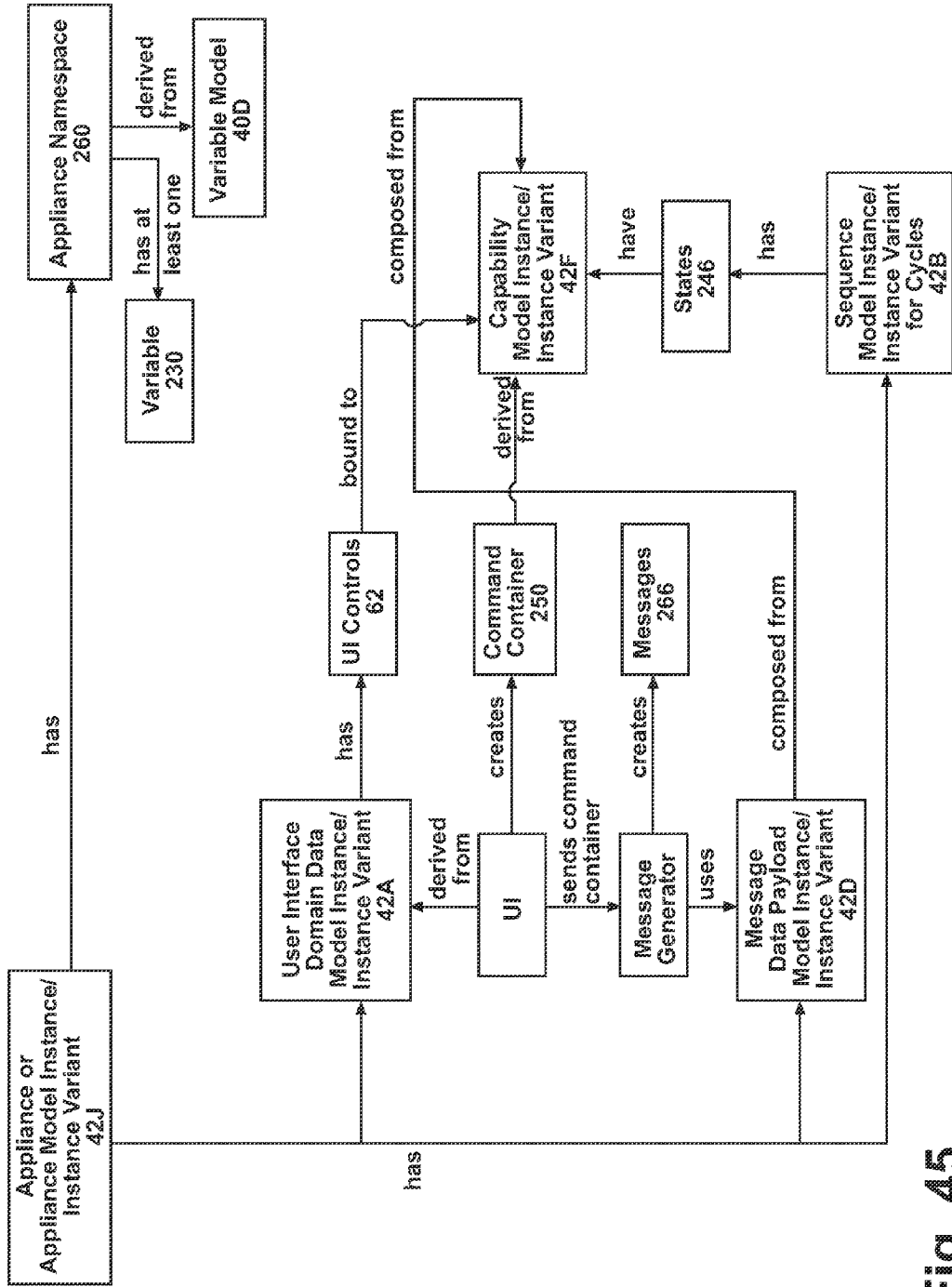

Fig. 45

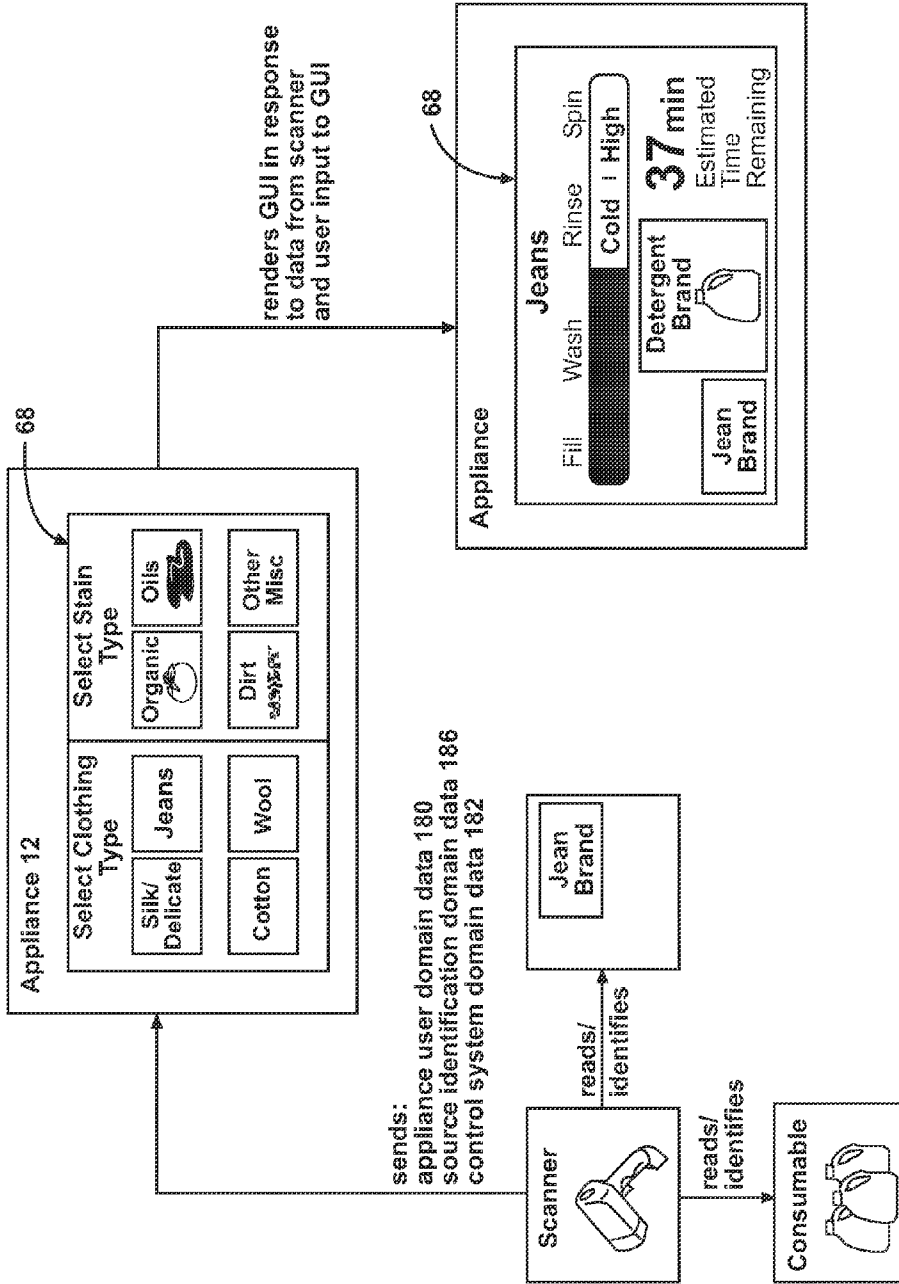

Fig. 46

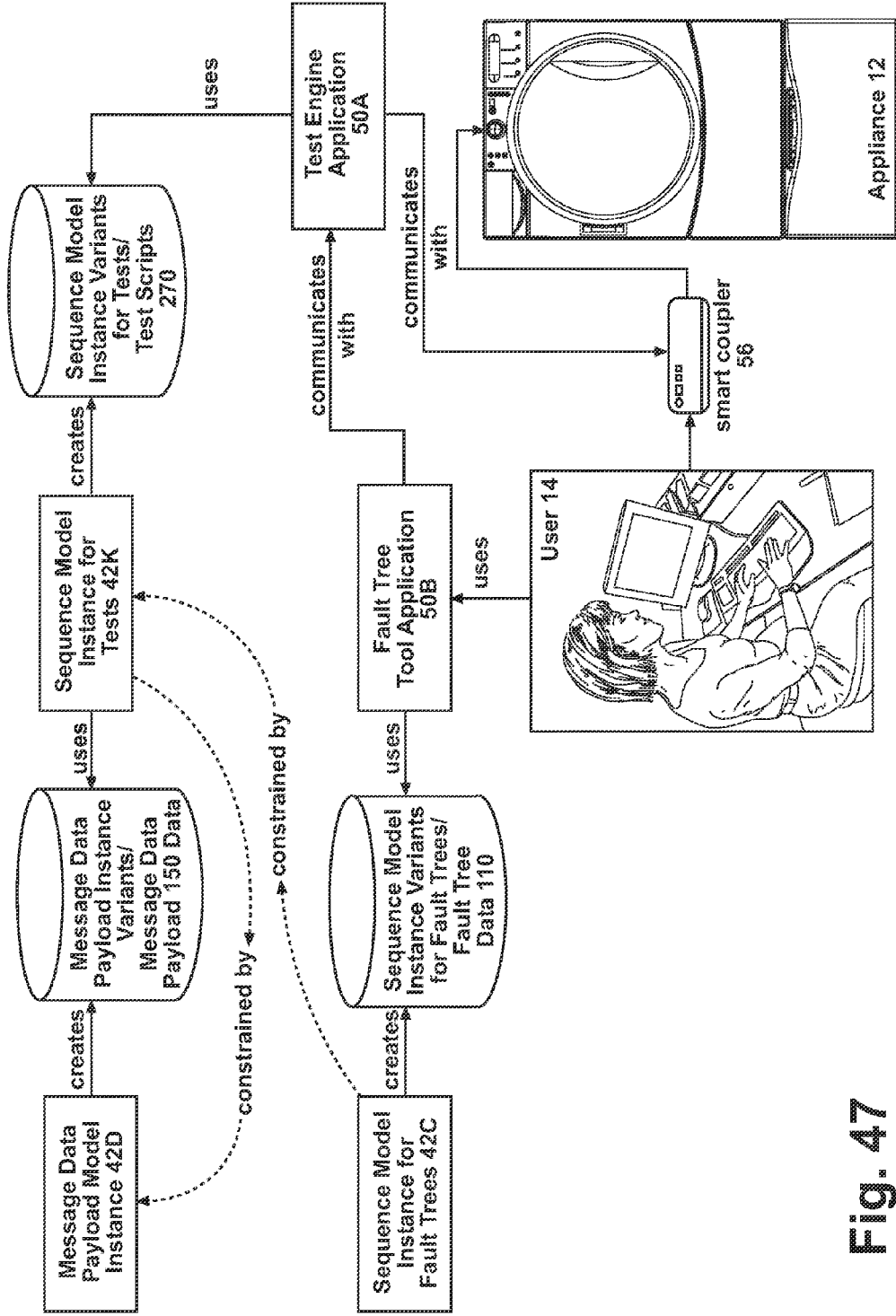
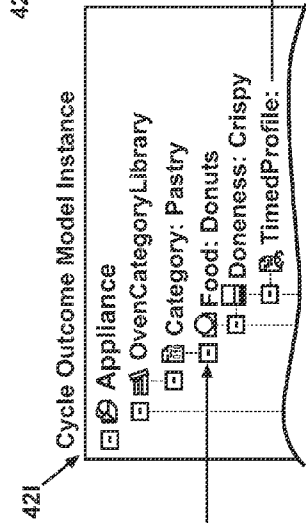
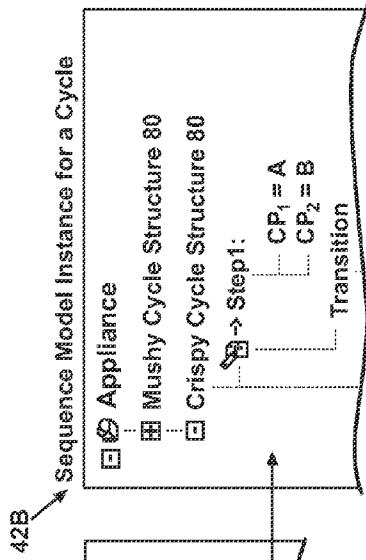

Fig. 47



From Fig. 48A cont.

To Fig. 48A cont.

From Fig. 48B cont.

To Fig. 48B cont.

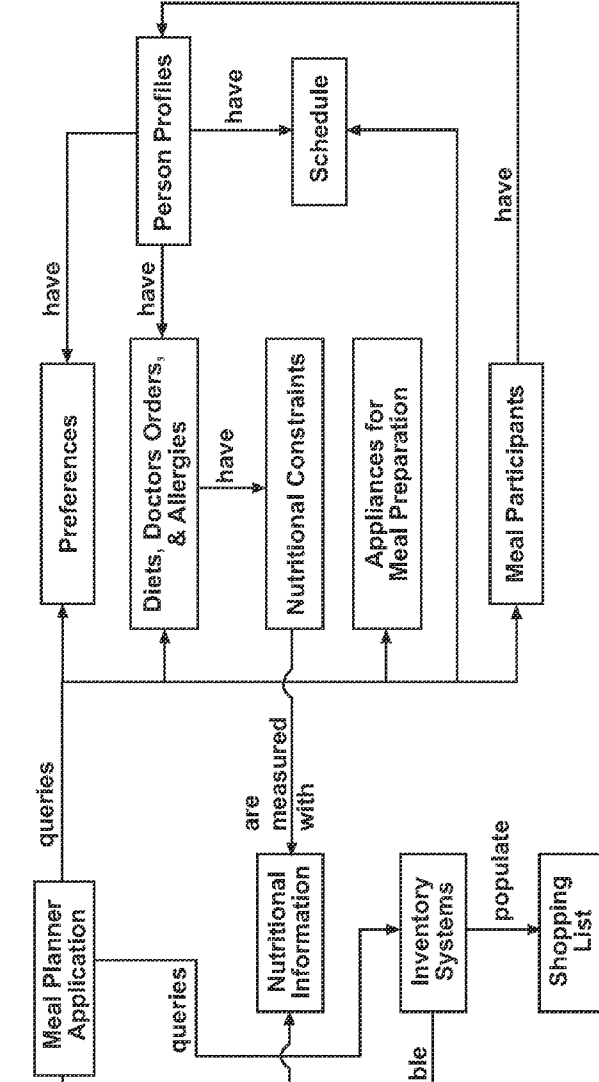

Fig. 48

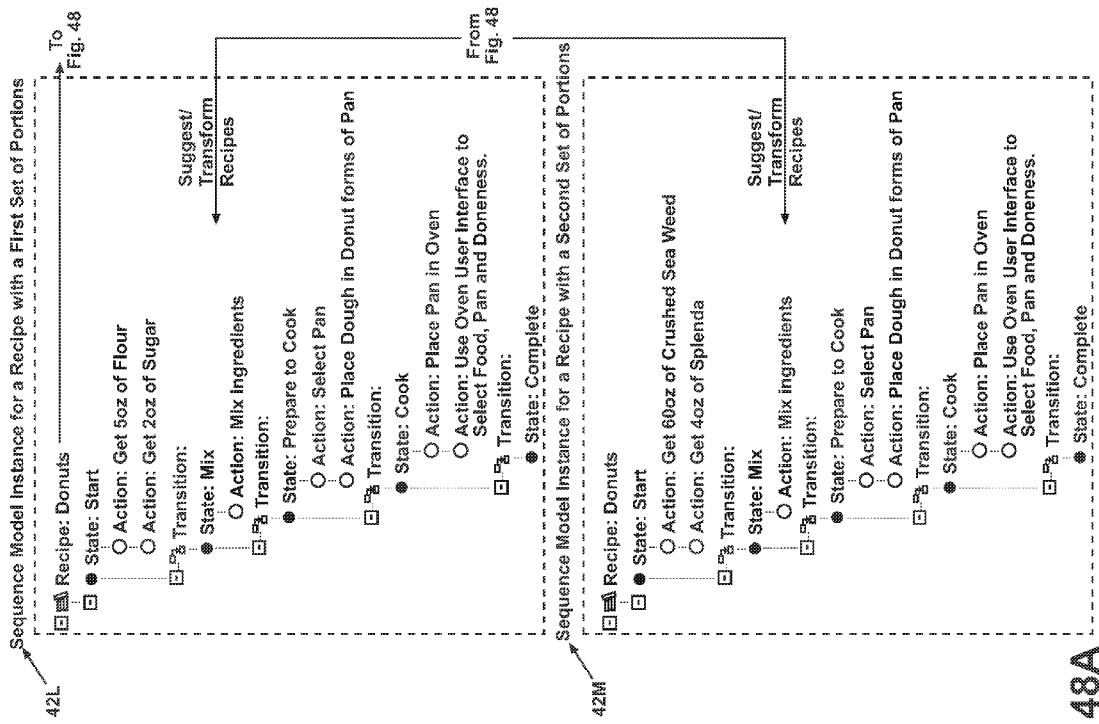

Fig. 48A

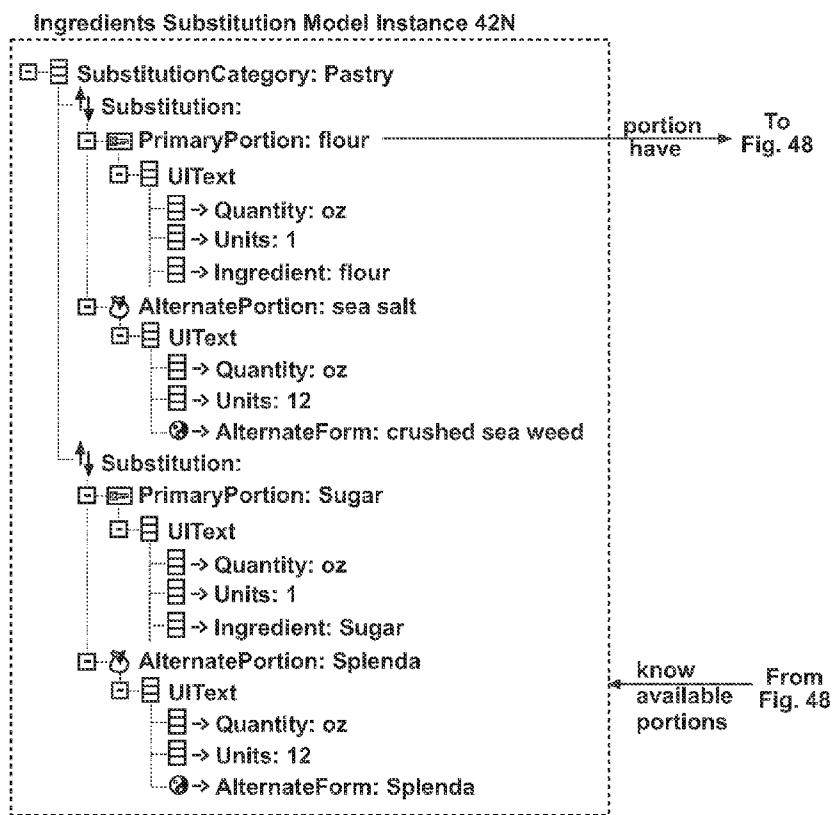

Fig. 48B

**APPLIANCE DEVELOPMENT TOOLKIT
WITH EDITOR FOR NAMESPACE
ALLOCATION**

**CROSS REFERENCE TO RELATED
APPLICATIONS**

[0001] This application is a continuation of PCT/US2009/046186 filed Jun. 3, 2009, which claims priority from U.S. Application Ser. No. 61/058,440 filed Jun. 3, 2008.

FIELD OF THE INVENTION

[0002] The invention relates to tools for editing software associated with the operation of household appliances.

DESCRIPTION OF THE RELATED ART

[0003] Household appliances typically comprise one or more components responsible for the electromechanical operations of the appliance. For example, an oven can include an appliance management component having a printed circuit board (PCB) with memory, as well as a user-interface component, such as a control panel or keypad, for a user to issue commands to the oven. As another example, a washing machine can include an appliance management component, a user-interface component, and a motor control component that controls a motor of the washing machine.

[0004] Typically, discrete circuits couple the internal components of an appliance, with each discrete circuit responsible for individual communication between related components. The circuits communicate with each other over an internal network that traditionally is implemented by hard-wired ribbon cables or other connectors or harnesses between the components. The hard-wired connectors form a closed system or network that is difficult or not possible to modify. For example, because the closed network relies on hard-coded or hard-wired network solutions, it is not practical to couple additional external components or additional internal components to the appliance to expand the capability or function of the appliance. The closed network cannot easily be adapted for communication with the additional external/internal components and therefore limits the potential of the appliance.

[0005] In some instances, service personnel can access the interior of an appliance and connect an external device to the internal network in order to modify the operation of or otherwise interact with the internal components of the appliance. However, scheduling appointments with service personnel can be inconvenient, and accessing the interior of the appliance can require the use of specialized tools and can potentially damage the appliance in the process. In addition, due to the limited potential of the internal components, the user of the appliance is unable to thoroughly personalize the operation of the appliance in order to tailor the appliance to his or her particular needs.

SUMMARY OF THE INVENTION

[0006] According to one aspect of the invention, an appliance development toolkit is provided to enable creation of content to affect operation of a component in an appliance or to affect user interaction with an appliance. The toolkit comprises an editor having a first interface element for creating information associated with the content, a second interface element to select an identifier from a namespace having a universe of identifiers, and a third interface element to associate the identifier with the information, an interactive user

interface on which the editor is displayed for use by a developer to observe and modify the creation, selection and association, and a converter to generate content using the identifier. The content identified by the identifier can be used by an appliance to affect operation of a component in an appliance or to affect user interaction with an appliance.

[0007] According to another aspect of the invention, a development toolkit is provided to enable creation of message data for a communications network. The toolkit comprises an editor having a first interface element for creating message data, a second interface element to allocate an identifier from a namespace having a universe of identifiers, and a third interface element to associate the identifier with the message data for communication in a message over the communications network wherein the allocation is registered at the namespace, and an interactive user interface on which the editor is displayed for use by a developer to observe and modify the allocation and association of the identifier. No other developer can use an identifier that has been allocated and the message data can be uniquely identified.

[0008] According to yet another aspect of the invention, a method is provided for allocating identifiers from a namespace for an appliance configured to perform a cycle of operation on an article wherein the appliance has a controller. The method comprises providing a system comprising a database a namespace having a universe of identifiers related to the operation of an appliance, storing in memory a state of each identifier in the namespace, receiving at least one request from a source to change the state of at least one identifier, authenticating in the system credentials associated with the source of the at least one request, selecting an identifier from the namespace in response to the request, and changing in the memory the state of the selected identifier according to the selection in response to the authentication and the selection. The state of the selected identifier determines the availability of the identifier for use by the appliance in performing the cycle of operation.

BRIEF DESCRIPTION OF THE DRAWINGS

[0009] In the drawings:

[0010] FIG. 1 is a schematic diagram showing the environment of an appliance development toolkit according to the invention.

[0011] FIG. 2 is a schematic diagram showing elements of an appliance development toolkit according to the invention.

[0012] FIG. 3 is a schematic diagram showing relationships among elements of the system configurator in the appliance development toolkit of FIGS. 1 and 2.

[0013] FIG. 4 is a diagram showing the functional relationship among some of the elements of FIG. 3.

[0014] FIG. 5 is a screen shot of an editor and a content viewer of an appliance development toolkit according to the invention.

[0015] FIG. 6A shows a first embodiment of a user interface as a result of using an appliance development toolkit according to the invention.

[0016] FIG. 6B shows a second embodiment of a user interface as a result of using an appliance development toolkit according to the invention.

[0017] FIG. 6C shows a third embodiment of a user interface as a result of using an appliance development toolkit according to the invention.

[0018] FIG. 7 is a screen shot of two editor windows in an appliance development toolkit according to the invention and a cycle structure for an appliance.

[0019] FIG. 8 is a schematic diagram showing the flow of information between an appliance and the system configurator in an appliance development toolkit according to the invention.

[0020] FIG. 9 is a schematic diagram showing the relationships of the control structure of an appliance to the system configurator of FIG. 8.

[0021] FIG. 10 is a screen shot of an editor in an appliance development toolkit according to the invention with a sequence model instance for a fault tree being created.

[0022] FIG. 10A is a screen shot of an attribute editor in an appliance development toolkit according to the invention showing the creation of a portion of the instance of FIG. 10.

[0023] FIG. 11 is a screen shot of an editor in an appliance development toolkit according to the invention with a sequence model instance for a fault tree being created.

[0024] FIG. 11A is a screen shot of a viewer in an appliance development toolkit according to the invention showing how the content resulting from the editor will appear.

[0025] FIG. 12 is a screen shot of the editor of FIGS. 10 and 11, and a screen shot of a graphical user interface in an appliance displaying a portion of the content from the editor.

[0026] FIG. 13A is a screen shot of the editor of FIGS. 10 and 11, and a screen shot of a graphical user interface in an appliance displaying another portion of the content from the editor in a query.

[0027] FIG. 13B is a screen shot of the editor of FIGS. 10 and 11, and a screen shot of a graphical user interface in an appliance displaying related portion of the content from the editor responsive to the query of FIG. 13A.

[0028] FIG. 14 is a screen shot of a viewer in an appliance development toolkit according to the invention showing a flow chart of the content in FIGS. 12-13B.

[0029] FIG. 15 illustrates an interaction between the content of FIGS. 12-13B and a user.

[0030] FIG. 16 is a screen shot of an editor in an appliance development toolkit according to the invention with a message data payload model instance being created

[0031] FIG. 17 is a schematic diagram showing the use of the message data payload model instance of FIG. 16 in an appliance.

[0032] FIG. 18 is a screen shot of a viewer in a target application showing the message traffic of the message data payload model instance of FIG. 16

[0033] FIG. 19 is a screen shot of a model instance editor in an appliance development toolkit according to the invention showing a step in the creation of a message data payload.

[0034] FIG. 20 is a screen shot of a model instance editor in an appliance development toolkit according to the invention showing another step in the creation of a message data payload.

[0035] FIG. 21 is a screen shot of a model instance editor in an appliance development toolkit according to the invention showing another step in the creation of a message data payload.

[0036] FIG. 22 is a screen shot of a model instance editor in an appliance development toolkit according to the invention showing another step in the creation of a message data payload.

[0037] FIG. 23 is a screen shot of a model instance editor in an appliance development toolkit according to the invention showing another step in the creation of a message data payload.

[0038] FIG. 24 is a schematic diagram showing a binding between appliance user domain data and control system domain data created by an editor in an appliance development toolkit according to the invention.

[0039] FIG. 25 is a schematic diagram showing use of a constrained appliance development toolkit according to the invention.

[0040] FIG. 26 is a schematic diagram showing a constrained appliance development toolkit according to the invention.

[0041] FIG. 27 is a screen shot of a model instance editor in an appliance development toolkit according to the invention showing aspects of a message data payload.

[0042] FIG. 28 is a schematic diagram showing elements of an appliance development toolkit according to the invention and an appliance that uses content from the appliance development toolkit in creating themes and animations.

[0043] FIG. 29 is a schematic diagram showing multiple bindings created by an appliance development toolkit according to the invention for user interface controls in an appliance.

[0044] FIG. 30 is a schematic diagram showing the message structure of forking elements in an appliance development toolkit according to the invention.

[0045] FIG. 31 is a screen shot of a model instance editor in an appliance development toolkit according to the invention showing a step in the creation of a message data payload with a forking element.

[0046] FIG. 32 is a screen shot of a model instance editor in an appliance development toolkit according to the invention showing another step in the creation of a message data payload with a forking element.

[0047] FIG. 33 is a screen shot of a model instance editor in an appliance development toolkit according to the invention with a properties viewer and information about it.

[0048] FIG. 34 is a screen shot of a model instance editor in an appliance development toolkit according to the invention with information about it.

[0049] FIG. 35 is a screen shot of a model instance editor in an appliance development toolkit according to the invention showing a step in the creation of a message data payload using holders.

[0050] FIG. 36 is a screen shot of a model instance editor in an appliance development toolkit according to the invention showing another step in the creation of a message data payload using holders.

[0051] FIG. 37 is a schematic diagram showing the use of holders in different a variable model according to the invention.

[0052] FIG. 38 is a schematic diagram showing a first scenario showing the relationships of variables.

[0053] FIG. 39 is a schematic diagram showing a second scenario showing the use and relationships of holders.

[0054] FIG. 40 is a schematic diagram showing a third scenario showing the use and relationships of holders.

[0055] FIG. 41 is a schematic diagram showing the use of paired elements in stain treatment in an appliance according to the invention.

[0056] FIG. 42 is a schematic diagram showing the use of development toolkits according to the invention with an appliance in the creation of cycle instances for the appliance.

[0057] FIG. 43 is a schematic diagram of a substitution model instance created according to the invention.

[0058] FIG. 44 is a schematic diagram showing the relationship between a cycle outcome model instance and sequence model instance according to the invention.

[0059] FIG. 45 is a schematic diagram showing the relationship among instance variants, user interface controls, and models according to the invention.

[0060] FIG. 46 is a schematic diagram showing a dynamic rendering of a graphical user interface in response an appliance receiving data from a sender according to the invention.

[0061] FIG. 47 is a schematic diagram showing the use of a test engine to diagnose an appliance according to the invention.

[0062] FIG. 48 is a schematic diagram showing the use of sequence model instances and cycle outcome model instances in meal planning according to the invention.

[0063] FIG. 48A illustrates a sequence model instance for recipes in FIG. 48.

[0064] FIG. 48B illustrates a sequence model instance for substitutions in FIG. 48.

DESCRIPTION OF EMBODIMENTS OF THE INVENTION

[0065] Referring to the drawings and to FIG. 1 in particular, an appliance development toolkit 10 according to the invention, which will be referred to hereinafter as the toolkit 10, is configured to enable the creation and modification of content 20 to affect and/or effect operation of one or more components associated with an appliance 12 so as to affect and/or effect interaction between a user 14 and the appliance 12 and/or a cycle of operation of the appliance 12. The toolkit 10 can be used with different appliances 12 without requiring the recoding of software of the toolkit 10. The user 14 can be a consumer, a salesperson, a manufacturer 14A (see FIG. 25), a product engineer, or any other individual capable of using the appliance 12 and/or the toolkit 10.

[0066] The appliance 12 can be any suitable appliance, such as a household appliance. Examples of household appliances include, but are not limited to, clothes washing machines, clothes dryers, ovens, dishwashers, refrigerators, freezers, microwave ovens, trash compactors, and countertop appliances, such as waffle makers, toasters, blenders, mixers, food processors, coffee makers, and the like.

[0067] The appliance 12 can be configured to perform a cycle of operation to complete a physical domestic operation on an article. Examples of the physical domestic operations include a food preparation operation, a food preservation operation, a fluid treatment operation, a cleaning operation, a personal care operation, a fabric treatment operation, an air treatment operation, and a hard surface treatment operation. The air treatment operation can comprise, for example, air purification, air humidification, air dehumidification, air heating, and air cooling. The food preparation operation can comprise, for example, food cleaning, food chopping, food mixing, food heating, food peeling, and food cooling. The food preservation operation can comprise, for example, food cooling, food freezing, and food storage in a specialized atmosphere. The fluid treatment operation can comprise, for example, fluid heating, fluid boiling, fluid cooling, fluid freezing, fluid mixing, fluid whipping, fluid dispensing, fluid filtering, and fluid separation. The cleaning operation can comprise, for example, dishwashing, fabric washing, fabric treatment, fabric drying, hard surface cleaning, hard surface

treatment, hard surface drying, carpet cleaning, carpet treatment, and carpet drying. The personal care operation can comprise, for example, hair treatment, nail treatment, body massaging, teeth cleaning, body cleaning, and shaving.

[0068] The components associated with the appliance 12 can include any devices, parts, software, and the like that participate in the operation of the appliance 12, either directly or indirectly. Some of the components have a corresponding controller (main controller, motor controller, user interface, etc.), which can be a simple microprocessor mounted on a printed circuit board (a control board), while other components can have no controller. The components can comprise one or more devices that are controlled by the controller. Typically, the controller components in cooperation, either directly or indirectly, through other components, control the operation of all of the components and the associated devices to implement a cycle of operation for the appliance 12.

[0069] The one or more components affected/effected by the toolkit 10 can comprise another appliance 12, one or more components on the appliance 12 or in another appliance 12, or an accessory device or component thereof for use with the appliance 12. For purposes of describing the invention, it will be understood that when reference is made herein to the use of the toolkit 10 in conjunction with the appliance 12, the same applies to the use of the toolkit 10 in conjunction with another appliance 12, with one or more components of the appliance 12 or of another appliance 12, and with an accessory device or component(s) thereof for use with the appliance 12.

[0070] The appliance 12 can be communicatively coupled to the toolkit 10 via a communications network 18 existing at least partially within the appliance 12 and/or at least partially external to the appliance 12 as appropriate. The communications network 18 comprises all of the coupling elements communicatively linking the various parts of the toolkit 10 and the appliance 12, as well as any coupling elements communicatively linking additional devices or resources to the toolkit 10 and/or appliance 12 (e.g. a coupling element connecting the appliance 12 with an accessory). For example, the communications network 18 can comprise an internal communications network of the appliance 12 enabling communication between the various components within the appliance 12, an external communications network connected to the toolkit 10, and a coupler for communicatively coupling the two networks. The coupler can comprise a communication driver configured to establish a communications link between the toolkit 10 and the appliance 12. Looking also at FIG. 2, the communication driver can be a smart driver 54 having expanded functionality enabling the smart driver 54 to create, modify, and/or interpret content 20. The communications network 18 can further comprises an additional communications connection between the appliance 12 and/or toolkit 10 and one or more additional devices, such as the accessory, an external network, a second appliance 12 or accessory, or one or more components thereof. As a non-limiting example, the additional communications connection can be to the Internet. The communications network 18 can comprise, at least in part, a smart coupler 56 as is disclosed in International Patent Application Publication No. 2009/058770, which is incorporated by reference herein in its entirety. The smart coupler 56 can incorporate the communications driver, which can be the smart driver 54.

[0071] The toolkit 10 enables a user 14 to create content 20 that can be provided to or otherwise obtained by one or more content targets 22 to affect the functionalities of the appliance

12. Content **20** can be formatted as at least one of a relational database, XML document, CSV file, binary file, data collection, memory structure, object structure, object graph, object tree, memory heap, machine code, source code, and text file, images, text, data elements, or other type of information associated with the toolkit **10** that can be interpreted, converted, propagated, created, modified, or otherwise used for some purpose by the toolkit **10**, the appliance **12**, or an associated device or component. Examples of content **20** include but are not limited to a cycle structure, a custom cycle, a branded cycle, user-attached data about appliance control functionality, a fault tree, a diagnostic test, an appliance user interface **64** (see FIG. 6A for example), appliance network communication, routing tables for appliance network communication, stain treatment, cooking, cooking algorithms, cooking vessels, meal preparation, dish preparation, recipes, units conversion, ingredients, ingredient substitution, dietary needs, appliance use and care, appliance FAQ, consumables meta data, and information associated with consumable, a cycle definition, cycle structure information, a paired element, source identification information, a message data payload structure, an electronic document that is human-readable, machine-readable, a communications specification/protocol, and information about a consumable.

[0072] Content **20** can comprise various forms of data or data elements, including appliance user domain data **180** (see FIG. 24), control system domain data **182** (see FIG. 24), and source identification domain data **186** (see FIG. 46). Appliance user domain data **180** includes information related to a user's **14** use of an appliance **12**. It includes such things as washing and cooking preferences, recipes, user demographics, choices and selections that user makes, and the like. Control system domain data **182** includes information related to the control and operation of an appliance. It includes such things as cycle structures, cycle definitions, message payloads, communication protocols, and the like. Source identification domain data **186** includes information related to the sources of goods and services and includes things such as trademarks, brand names, service marks, jingles, and the like. User interface domain data includes information related to interacting with a user interface **64**, which is preferably a graphical user interface **68**. It includes such things as widgets, animation definitions, buttons, bars, sliders, knobs, and the like, whether real or virtual.

[0073] A content target **22** comprises any entity that receives content **20**. Non-limiting examples of different content targets **22** include the toolkit **10**, the appliance **12**, the communications network **18**, a system configurator **28**, editors **30** and **32**, converters **34**, viewers **38**, an appliance control system **90**, a user interface **64** and graphical user interface **68**, a web browser or web page, a personal computer **70**, an application **50**, a computer program, a handheld device, a remote client **72** such as a cell phone, a printer, and any hardware or software components or devices associated therewith or included therein.

[0074] As shown in FIGS. 2-4, the toolkit **10** comprises system configurator **28** having a model editor **30**, a model instance editor **32**, and one or more converters **34** configured to enable a user **14** to create, modify, and/or propagate content **20**, such as models **40**, model instances **42**, and model instance variants **44**, respectively. The toolkit **10** can further comprise one or more viewers **38** that function as content targets **22** and provide a visual display corresponding to the received content **20**. Depending on the particular type of

viewer **38** being used, viewers **38** can produce one or more of a variety of different displays or views ranging from schematic diagrams to code to images. The communications network **18** is configured to establish a communicative link between the system configurator **28** and at least one component associated with the appliance **12**.

[0075] Different content targets **22** can use the same content **20** for different purposes. For example, a model instance editor **32** that receives content **20** in the form of a model instance **42** can provide a visual diagram of the model instance **42** and enable the user **14** to edit the model instance **42**. However, if the same model instance **42** is sent to the appliance **12**, the appliance **12** can be enabled with new operational capabilities, such as new cycles of operation. In another example shown in FIGS. 5 and 6A, the appliance **12** can receive the model instance **42** from the model instance editor **32** and provide the model instance **42** to a graphical user interface **68** of the appliance **12** in order to cause the graphical user interface **68** to display certain images and text.

[0076] Converters **34** can enable the flexible usage of content **20** by converting data elements or content **20** created by one of the editors **30**, **32** into content **20** of a form suitable for use by a particular content target **22**. For example, a type of converter **34** called a model instance converter is configured to produce a model instance variant **44** based on a model instance **42**. Another type of converter **34** called a simple converter can simply propagate data elements or a file stored in memory and comprising data elements created by the toolkit **10** without having to substantially convert the data elements. Simple converters are best used when the content target **22** can operate directly on the data elements created by editors **30**, **32**, such as a content target **22** in the form of a viewer **38** included in the system configurator **28**. Converters **34** are typically used to enable the transfer of data elements amongst the various entities of the toolkit **10** and appliance **12**. A converter **34** can potentially also act as an exporter, which functions similarly to the propagating function described previously. The toolkit **10** can also include a converter **34** in the form of an encoder to encode content **20** onto a consumable information holder or other component.

[0077] The system configurator **28** can optionally further comprise one or more applications **50**, which can also include one or more viewers **38** and can use content **20** provided by the system configurator **28**. One or more applications **50** can also be communicatively coupled to but not included within the system configurator **28**. Content **20** provided by the system configurator **28** can optionally be supplemented by content **20** provided by or created using resources **46**, which can include any entities capable of producing content **20** or being used by another entity to generate content **20**.

[0078] For testing, diagnostic, and engineering purposes, a link can be established between the system configurator **28** and a content target simulator **52** (FIG. 2). The content target simulator **52** typically comprises software and is intended to provide a realistic simulation of the operation of the appliance **12**. The toolkit **10** thus comprises software configured to enable a user **14** to effectively command operation of the appliance **12** or of an appliance simulator and to create data or data elements for display to a user **14** as content **20** in a viewer **38** of the toolkit **10** based on the operation of the appliance **12**. The user **14** can observe the content **20** in the viewer **38** and create or modify the content **20** using the toolkit **10** in response to communication over the communications network **18** and link.

[0079] A model 40 is a very robust, thorough, and thoroughly-vetted collection of data elements or structures equivalent to a UML class diagram. A model 40 consists of a plurality of class definitions where each class has a plurality of properties and each class can reference other classes a minimum and maximum number of times, which may be infinite. Classes can reference other classes via a named property. Classes can also, in effect, serve as extensions of other classes in order to inherit their functionalities, property definitions, and references. Classes can implement interfaces, which are definitions of collections of functions each having a set of arguments, wherein each argument can be set to one of a set of valid values. The purpose of the class definition is to provide rules or constraints for creating model instances 42 and model instance variants 44, which are, in essence, runtime instances of the model 40. Thus, the toolkit 10, in effect, enables users 14 to create runtime instances of a class diagram and is configured to create, manage, and/or edit models 40, model instances 42, and model instance variants 44, as well as data elements or information associated therewith, that are configured to effect the functionality of one or more components associated with the appliance 12.

[0080] As described in more detail hereinafter with respect to FIGS. 25 and 26, the model editor 40 is typically used by a user 14 associated with the manufacturer 14A of the toolkit 10 or of the appliance 12, such as an engineer or software developer, to refine and constrain models 40 prior to the models 40 being made available to users 14 external to the manufacturer 14A. The provides the manufacturer 14A with the ability to control the specific toolkit 10 functionalities available to users 14 outside the company, and, in doing so, provides the ability for the manufacturer 14A to offer and sell licenses for the toolkit 10 that enable users 14 access to only certain levels of functionality. Each particular model 40 in essence is a template or a plurality of constraints defining at least part of the functionality of the system configurator 28. Each model 40 enables at least one model instance editor 42 and defines the functionalities of the model instance editor 42. Thus, n models 40 can be used with the toolkit 10 to generate n instances of data elements derived therefrom. An exemplary data element can comprise at least one representation of a portion of a message data payload to be sent across the communications network 18.

[0081] The model instance editor 42 creates instances of data elements that comprise a model instance 42 and that are related to appliance 12 functionality and derived from the appliance user domain data 180 model. The model instance editor 42 is configured at least in part by the appliance user domain data 180 model irrespective of the appliance 12 so that the toolkit 10 can be used with different appliances 12. Validation rules, which essentially comprise a communications protocol, for the content 20 can be derived from the appliance user domain model. The model instance 42 can comprise a hierarchical data structure, a graph, a fault tree, or a relational database and can be configured or developed by a user 14 interacting with the user interface 64.

[0082] Referring now to FIGS. 5-7, models 40 can be grouped into a variety of types based on the function of the model 40 and model instances 42 created therefrom. A user interface domain data model 40A can be used to create user interface domain data model instances 42A, such as that illustrated in FIGS. 5 and 7, which are used to control the functionality of a user interface 64 of the appliance 12, which can be a graphical user interface 68. In this example, the user

interface domain data model instance 42A includes user interface control objects 60A-C displayed in the model instance editor 32 and corresponding to each of three user interface controls 62A-C to be displayed on the user interface 64 of the appliance 12. The user interface control objects 60A-C are converted or propagated by a converter 34 included in the system configurator 28 into content 20, which is sent to a content target 22 of the system configurator 28, the viewer 38. Looking now to FIG. 6A, the viewer 38 then creates a rendering of the graphical user interface 68 as it would appear on the appliance 12 once the user interface domain data model instance 42A has been sent to the appliance 12 as content 20. This simulation enables the user 14 to observe and, if desired, modify the appearance of the graphical user interface 68 without having to repeatedly reprogram the appliance 12 itself. As illustrated in FIGS. 6B and 6C, the user interface domain data model instance 42A can also be sent to other content targets 22, such as a personal computer 70 or a remote client 72, as content 20 to enable the user 14 to visualize the user interface 64 and tailor the user interface 64 to his or her particular needs and tastes.

[0083] A sequence model 40B as shown in FIG. 7 is another type of model 40 that can be used to create cycles, fault trees, recipes, and tests (see also FIG. 47). As described herein, the same sequence model 40B can be used to generate a variety of different types of sequence model instances (e.g. instances for a cycle, a fault tree, a recipe, or a test). In some alternative embodiments, multiple sequence models can be required to generate the different types of sequence model instances. A sequence model instance for a cycle 42B that is derived from the sequence model 40B is illustrated as a content target 22 of the user interface domain data model instance 42A. In this example, an object 60A of the sequence model instance for a cycle 42B corresponding to a user interface control 62A for dispensing ice is propagated or, if necessary, converted by a converter 34 associated with the user interface domain data model instance 42A or sequence model instance for a cycle 42B into the appropriate format and is provided to the sequence model instance for a cycle 42B.

[0084] Due to this binding of user interface domain data of the user interface domain data model instance 42A and control system domain data 182 of the sequence model instance for a cycle 42B, when a user 14 actuates the user interface control 62A, the transition will be initiated, and the cycle specified by the sequence model instance for a cycle 42B and created in the manner explained below will be carried out to produce ice.

[0085] Objects can be composed of a plurality of other objects according to the objects field definitions. If an object comprises a method which has executable software to set the value of a field defined to hold an object, then that object can be reconfigured by changing the value of the field from a first object to a second object. This reconfiguration can then result in a different composite or overall appliance control system 90 behavior. There are many useful purposes for an appliance control system 90 whose behavior can be changed by changing the values in a first objects field to a third object from a second object. For example, a cycle accessory could use this technique to change a cycle structure 80. Likewise, both a consumables reader and a recipe book wand could use these techniques to customize the behavior of the appliance control system 90 according to appliance user domain data

180, source identification domain data 186, user interface domain data the data about the cycle, data about a consumable, and the like.

[0086] There are many mechanisms which can initiate and manage the dynamic configuration of an appliance control system 90. However, these mechanisms (see FIG. 34) will need a common design framework with which to accomplish the dynamic configuration. Some portions of the dynamic configuration can be accomplished during the compile process, while other portions may be accomplished at post-compile time (also known as runtime).

[0087] FIG. 7 illustrates several ways that the appliance 12 can obtain information necessary to carry out appliance 12 operation, including information about cycles of operation, and generate a cycle structure to perform a cycle of operation. Here, cycle structure information 82 represents information about or associated with a cycle structure 80 to be produced by the cycle engine 88. Cycle structure information 82 can include modifications to be made to an existing cycle structure 80, information to be used to create a new cycle structure 80, or a cycle structure requiring conversion or some sort of manipulation into a cycle structure 80 suitable for use with the particular appliance 12. Cycle structure 80 represents a set of instructions for use by the appliance control system 90 of the appliance 12 for carrying out a cycle of operation. An exemplary appliance control system 90 is illustrated in FIG. 9 and is described in detail by International Patent Application Publication No. 2006/135758, which is incorporated by reference herein in its entirety. In one embodiment, the cycle structure 80 can be created by using messaging for communicating the cycle structure information 82 to the cycle architecture 86 via the communications network 18, at which point the cycle engine 88 can discover information for creating or modifying cycle structure 80 for use by the appliance control system 90. The cycle engine 88 then proceeds to build a new or modified functional cycle structure 80. Optionally all messages can be routed through an embedded virtual router (EVR) 92, which results in the cycle engine 88 using its own configuration API for building the new or modified cycle structure 80. The execution by the cycle engine 88 to create or modify the cycle structure 80 can also be accomplished through the EVR 92.

[0088] An arbitrary software component 94 in communication with the cycle engine 88 or in communication with the cycle architecture 86 can also be used to create a new or modified cycle structure 80. The arbitrary software component 94 can reside in a variety of locations with respect to a controller component comprising the cycle architecture 86. Hence, all messages between the arbitrary software component 94 and the cycle architecture 86 can be optionally routed through an EVR 92 across the communications network 18. As well, the cycle architecture 86 can optionally communicate with the appliance control system 90 through an EVR 92.

[0089] In another scenario, an operational cycle accessory, such as the toolkit 10, can be communicatively coupled to the communications network 18, discover the cycle architecture 86, and send the cycle architecture 86 messages to affect its structure and, ultimately, its execution. In this case, the operational cycle accessory would typically include a combination of software and data to accomplish the configuration of the cycle architecture 86. Alternately, the aforementioned cycle architecture might send a discovery message seeking identification of all sources of the cycle structure 80. Sources of the cycle structure may be in ROM, Flash, EE Prom, an operational cycle component, and/or an external source connected

to the communications network 18. Once the cycle structure information 82 located and retrieved, the cycle engine 88 can commence modifying its own cycle structures 80 according to the new cycle structure data. As shown in FIG. 7, when the converters 34 associated with the cycle structure information 82 and the cycle structure 80, read the sequence model instance for a cycle 42B, the converter 34 associated with the cycle structure information converts the sequence model instance for a cycle 42B into cycle structure information 82, and the converter 34 associated with the cycle structure converts the sequence model instance for a cycle 42B directly into a cycle structure 80. Both the cycle structure information 82 and the cycle structure 80 generated by the associated converters 34 are generated based on the same content 20 comprising the sequence model instance for a cycle 42B.

[0090] In another embodiment of a cycle architecture 86, a first portion of the cycle structure information 82 is compiled and a second portion is made available at runtime. The second portion can include a plurality of cycle structure data, either in direct or indirect form, which can be combined with the first portion such that the cycle engine 88 operates on the aggregate of the first and second portions to create operational cycle execution software. The second portion can represent differences in the first portion where differences may be additions, deletions, or modifications to elements, their relative orders, or their relative relationships within the cycle structure 80. The cycle engine 88 can appropriately apply the differences represented in the second portion by looking at the identifiers of the elements of the first portion of the cycle structure information 82 and the identifiers of the elements of the second portion of the cycle structure information 82. The advantage of this embodiment of a cycle architecture 86 is that changes to the aggregate cycle structure 80 can be made while preserving the first portion such that subsequent corruption or absence of the second portion would not effect the integrity of the first portion, thus enabling the operation cycle execution software to revert to compiled default state, such as might be supplied at the factory. A second advantage of this embodiment is that specialized variants of the first portion can be designed which can accommodate the constraints presented by the appliance control system 90 and more specifically the controlling components of the appliance 12 such as limited memory and also provide capability for receiving and adapting to a second portion, providing flexibility and configurability within the constraints for the cost of the specialized variants. For appliances 12, this can be an important requirement in some cases.

[0091] Alternatively, when an operation cycle accessory is disconnected from the cycle engine 88, the data of the second portion can be optionally removed by the cycle engine 88, causing a reversion to the factory default state. This is a form of anti-piracy protection in that the operation cycle accessory must be present for the additional functionality represented by the accessory to be available to the appliance 12. Optionally, the connection between the appliance 12 and the operation cycle accessory can include a transfer of the first portion into a memory in the appliance 12. In this case, additional operation cycles can be retained without the permanent presence of the operational cycle accessory. It should also be noted that an operation cycle accessory can be virtual in that the software and data and ability to communicate with the cycle engine 88 can reside on an external device connected to the cycle engine 88 via communications network 18, and not physically attached to the containing appliance 12.

[0092] It is to be noted that an operational cycle component can have other elements that are not the aforementioned operation cycles or constituent data and compiled portions. For example, the operational cycle component can include software code to configure a cycle engine 88 for communication and other functions or code to put software architecture into an alternate mode for the purpose of diagnostics or changing memory.

[0093] An appliance cycle of operation performed by the appliance control system 90 can be optimized by information associated with consumables on which the appliance is operating. For example, the cycle structure 80 could be built specifically to accommodate some properties or attributes of the consumable or to accommodate some properties or attributes of a consumable holder. The body or bodies that comprise information, identifiers of functionalities, properties, attributes, and property and attribute values related to consumables can be referred to as sources of information about a consumable or “consumable information holders.” Examples of consumable information holders include the consumable itself, a data pod, the consumable holder, a user interface, and a tag. The consumable holder can be a sensing consumable holder that might use a lid sensor, for example, for sensing attributes about the consumable contained therein. These attributes could then be used by the appliance 12 to further refine operation of the consumable holder. For example, if a particular consumable holder is supposed to dispense 2 ounces, a lid with an amount sensor could be configured with an analog circuit coupled to the appliance 12 to provide a level or volume feedback so that the appliance 12 can dispense exactly 2 ounces rather than a time-based approximation.

[0094] Information associated with a consumable can include amount and/or composition or other attributes that would characterize the magnitude of the usefulness of the consumable. In this case, the cycle architecture 86 may adapt itself based on the information. For example, if the consumable were a dishwashing rinse aid and the consumable holder had only 90% of the standard dose, the cycle architecture 86 might adapt itself to this condition by increasing the time of the rinse phase to compensate for the lack of rinse aid. Information associated with a consumable can also include parameters of an operating cycle such as personal preferences of a user 14 (e.g., doneness or crispiness preferences), and data about the consumable holder, the appliance 12, or other accessories or components thereof.

[0095] In a laundry example, the appliance control system 90 may provide information to the cycle architecture 86 about process variables like soil level, load size, soil type, etc. Based on this information associated with a consumable, including the process variable information, the cycle architecture 86 or an arbitrary software component 94 in conjunction with a cycle engine 88 can reconfigure the cycle structure 80 to adapt to the process variable information. The consumable holder may comprise the arbitrary software component 94 and be able to reconfigure the cycle structure 80 to adapt to the process variable information. Reconfiguration can be accomplished in at least two ways. In one way, the arbitrary software component 94 can read the cycle structure 80 and communicate with the cycle engine 88. In a second way, an arbitrary software component 94 can be preconfigured and communicate that configuration to or instruct the cycle engine 88 about the configuration.

[0096] One example of commands associated with an operating cycle is a collection of key value pairs. Keys comprise parameter names having a meaning, wherein the meaning is known by the cycle engine 88 such that values associated with the keys are thereby associated with the meanings. This enables the values to be used in the contexts of the meanings to modify and/or control the cycle of operation of the appliance 12.

[0097] Another example of commands associated with an operating cycle is a byte array representing a message packet for a network. In one embodiment of this example, the byte array could be arranged according to the packet definition disclosed in WO2006135726 comprising a functional identifier, an op code, and a message data payload, wherein the identifier and op code relate to an executable function or method implemented by the cycle engine 88 and or cycle engine API. Further, the arguments or parameters of the function or method correspond to the data elements contained in the payload of the message packet.

[0098] The consumable holder, therefore, can contain all the functionality of and participate in all the embodiments that an operational cycle accessory in communication with an appliance 12 having a cycle architecture 86 can. Therefore in one embodiment, a consumable holder is an operation cycle accessory that further physically contains and can also further be enabled to directly actuate the introduction of a consumable into an appliance 12.

[0099] As seen in FIG. 8, content 20 can be derived from or provided by components or resources 46 outside the appliance 12 (external content 20) or from memory or other information contained within the appliance 12 (internal content 20) and acquired by a content 20 acquisitioner 102. Appliance software framework 104, which includes the cycle architecture 86 of FIG. 7, receives the content 20 and creates appliance control functionality 100. The appliance control functionality 100 provides and controls the user interface 64 and user interaction, as well as provides and controls the appliance control system 90. As an example, FIG. 9 also illustrates the appliance control system 90 disclosed in International Patent Application Publication No. 2006/135758 and further includes the system configurator 28 for managing the functionality thereof.

[0100] As shown in FIGS. 10-15, sequence model 40B can also be used to generate a sequence model instance for a fault tree 42C. Appliances 12 are often diagnosed and serviced using an appliance fault tree 110, and the sequence model instance for a fault tree 42C serves to present a user 14 with various displays or views on the user interface 64 informing the user 14 of possible problems and solutions associated with the appliance 12. The initial step of an appliance fault tree 110 will normally be associated with a symptom of failure or state of the appliance 12.

[0101] With continued reference to FIGS. 10-15, the exemplary initial step is performed upon determination of a state of the appliance 12 in which the user 14 is experiencing slow or no water dispensing. Each step of the appliance fault tree 110 including the initial step can have one or more associated actions. Actions can be various tasks or checks performed at each step. Exemplary actions can comprise, but are not limited to, taking a measurement, asking a question, requesting user input, describing an observation, and the like. The exemplary action associated with the initial step is to ask a ques-

tion, “Is the refrigerator connected to a water supply?” The action can also comprise obtaining the answer, which can be “Yes” or “No.”

[0102] Transitions are paths to other steps in the fault tree **110** and that are normally conditional on the result of a given step or action. At each step of the sequence model instance for a fault tree **42C**, an action can be performed comprising asking a question regarding operation of the appliance **12**, and the question can be presented on the user interface **64**. Once an answer to the question has been obtained, the sequence model instance for a fault tree **42C** will perform a transition to another step in the appliance fault tree **110**. As shown in FIG. **11A**, each question will also have corresponding content **20** that is displayed on the user interface **64**. Typically, question-based content **20** will include buttons or other user interface controls **62D**, **62E** that will enable the user **14** to input an answer to the question. Alternatively, the appliance **12** can automatically determine the answer to the question using various components, such as sensors. Thus, an answer can be obtained either via user interaction with the appliance **12** via the user interface controls **62**, or an associated device, or automatically by the components of the appliance **12** or an associated device.

[0103] As shown in FIG. **10**, when an answer of “Yes” is obtained when the initial step is carried out, the appliance fault tree **110** can transition to the next step. Thus, the question and answer function as arguments that, in combination, form a conditional statement in the appliance fault tree **110**. While proceeding through the appliance fault tree **110**, the specific steps, actions, and transitions are performed based on whether the various conditional statements in the appliance fault tree **110** are true or false. If a conditional statement is false, no transition will occur, and the appliance fault tree **110** will proceed in order. If a conditional statement is true, then a transition can be performed, which can act as a path to a particular step, action, and/or transition. In some cases, the action can be displaying a solution on the user interface **64**.

[0104] As shown in FIG. **10A**, an answer determination attribute editor **120**, which is also a component of the model instance editor **32**, can be used to edit the content **20** displayed to the user **14** at a given transition corresponding to a given question and answer conditional statement. The answer determination attribute editor **120** is illustrated as having a number of well-known elements frequently included in computer-based editing applications, such as clickable buttons **122**, a display window or viewer **38**, and a text entry box **124**.

[0105] As shown in FIGS. **12-15**, the sequence model instance for a fault tree **42C** can also be used to present a use and care guide **130** to the user **14** via the user interface **64** of the appliance **12**, which can comprise the GUI **68**. Content **20** comprising text to be displayed to the user **14** can be created using a document model instance **42G** (FIG. **43**) for a use and care guide **130**, which specifies content **20** can be displayed on the user interface **64** that enables a user **14** to select a symptom **132** included in the use and care guide **130**. The selection of a symptom **132** can automatically bias the user **14** to an entry or starting point in the sequence model instance for a fault tree **42C** so that the user **14** does not have to waste time looking through irrelevant symptoms. In addition, a given appliance **12** can have more than one fault tree **110** associated with it. For example, there can be a fault tree **110** associated with different components or different subsystems in the appliance **12**. There can also be different fault trees **110** associated with accessories connected to the appliance **12**,

and each fault tree **110** can have an initial step **A** that would normally serve as the starting point for entry into the respective fault tree **110**. It may be, and often is the case, that any given fault tree **110** for an appliance **12** might have multiple entry points. Further, a transition, as discussed previously with respect to FIGS. **10-15**, is not limited to transitioning to a sequential step within the same fault tree **110**. For example, a transition from a first step on a fault tree **110** can lead to a second step on another fault tree **110**.

[0106] The fault tree **110** and/or use and care guide **130** provided by the sequence model instance for a fault tree **42C** can also be presented in a viewer **38** as content **20** in the form of a diagram **140** as shown in FIGS. **14** and **15**. The user **14** can troubleshoot problems by simply using a content target **22** capable of presenting the content **20**. For example, as shown, a user **14** can use the personal computer **70** to view a web page including the information, or the user can use a printer **142** to print out a copy of the diagram **140**. In either instance, the sequence model instance for a fault tree **42C** can be used to diagnose problems and potentially find a solution without requiring a visit from a serviceperson.

[0107] Looking now to FIGS. **16-23**, a message data payload model instance **42D** is used to manage message data payloads **150** comprising a first portion **152** having usable data and a second portion **154** having information to describe the usable data. The first and second portions **152**, **154** can comprise an ordered collection of message elements **156** or at least one message element **156**. One of the first and second portions **152**, **154** can have a direct or indirect reference to the other of the first and second portions **152**, **154**, which can effectively bind the portions. The constraints defined by the model **40** can be used within the model instance editor **32** to create the association between the first and second portions **152**, **154**. Various message elements **156** can be compiled to create a portion **152**, **154** using the model instance editor **32** during creation of the message data payload **150** and can comprise meaningful text describing the meaning of the message element **156**. Usable data from the communications network **18** can be combined with non-usable data describing the usable data wherein the user **14** can understand the meaning of the usable data. Based on the message data payload model instance **42D** and the properties **158** thereof, a viewer **38** can display a complete specification **160** that updates in real time as the user **14** edits the message data payload model instance **42D** and properties thereof.

[0108] Specifically, FIGS. **16-18** show the creation and advantages of useable data in the inventive appliance development toolkit **10**. The system configurator **28** displays the message data model instance **42D** in the model instance editor **32**, a viewer **38** showing properties **158**, and a viewer **38** showing the specification **160**. Elements and choices of a command structure or sequence are created in the model instance editor **32** as an instance of a message data payload **150**. A first portion **152** of a message element **156** comprises useable data and is set in byte **1**. A second portion **154** identifies the first portion **152** and is set in this example in byte **0**. The model instance editor **32** can have constraints that limit or guide what a use can do in creating message payloads **150**. In any event, the model instance editor **32** creates an association between the first and second portions **152**, **154** where rules for data representation provided by the communications network **18** over which the message payload **150** is to be sent provide the constraints.

[0109] A user interface 64 or viewer 3 can display a visualization of the message data payload 150 from the model instance editor 32 so that a user 14 can conveniently create the message data payload 150 for immediate use and see a graphical representation of the message data payload 150 as it is created. An example of that display is seen in FIGS. 17 and 18. In FIG. 17, a viewer associated with an application 50 can display relevant data including the identifiers (second portion). As shown in FIG. 18, a specialized viewer 38 associated with an application 50 or, alternatively, incorporated directly into the system configurator 28 can also be associated with a command generator 170 such that the associated viewer 38 displays the various message elements 156 of the message data payload 150 and the command generator 170 enables the user 14 to define and initiate the sending of a message data payload 150 to affect the operation of the appliance 12. The command generator 17 can include one or more buttons 122 for initiating the sending of a defined message data payload 150.

[0110] FIGS. 19-23 show in steps the creation of a message data payload model instance 42D using variables, values, and value holders, which will be described in more detail hereinafter in FIG. 37. See the description of holders, infra. As well, FIG. 20 shows the use of menus 174 and forms 176 for guiding or limiting a user 14 in selecting and inputting information according to the constraints. An error message 172 can be displayed if a property 158 or parameter associated therewith is incorrect or improper according to the constraints. A model instance editor 32, which includes constraints as will be discussed in more detail hereinafter, is constrained by a model 40. In FIG. 20, an API object has been selected and the user 14 has right clicked the object, bringing up menu 174 having an "Insert New" feature. Referring to a message data payload model 40C of FIG. 37, an API is allowed to have a minimum of zero relationships with a message data payload 150 and a maximum of n or infinite relationships with a message data payload 150. Therefore, if the user selects the "Insert New" item on the menu 174, a sub-menu (not shown) or form 176 can appear, enabling the user 14 to choose to create a message data payload object. In this case, the model instance editor 32 reads the model 40 such that it is informed by the model 40 what the possible relationships between each current and potential objects are so that the model instance editor 32 editor can configure its functionality from the information in the model 40 so as to constrain itself according to the model 40. In this way, a constrained appliance development toolkit 10 constrained by a model 40 can limit the types of objects created and the available relationships between objects which in turn limits the ability to create content 20, which in turn limits the appliance control functionality.

[0111] FIG. 24 illustrates types of model instances 42 that can be associated or bound by the model instance editor 32 of the appliance development toolkit 10. Essentially anything in the different domains of data can be bound for later use. Although appliance user domain data 180 and control system domain data 182 are here shown, it will be understood that binding among other domains is equally within the scope of the invention, e.g., user interface domain data 184 and/or source identification domain 186 data.

[0112] FIG. 25 illustrates the benefit of constraining the development toolkit 10 for use by users who want to create content 20 for effecting the cycle of operation of the user interaction of an appliance 12 but do not have all the engi-

neering skills or knowledge to do so. The constrained development toolkit 10 enables a user 14 that has less than all the required knowledge or skills to create content 20 that effects the cycle of operation or the user interaction of an appliance 12 wherein the effect is less than the full effect that content 20 from an unconstrained appliance development toolkit 10 can create. The constraints used to constrain use of the toolkit 10 can be specified within a model 40. It is to be understood that for the purposes of describing the invention, unless otherwise specified, reference to the toolkit 10 herein can be understood as a reference to a constrained toolkit and/or an unconstrained toolkit.

[0113] Appliance manufactures build appliances for a competitive market and compete with one another in the areas of cost and innovation. Accordingly, manufacturers 14A must continuously invest in new products, new technologies, and new innovations while simultaneously reducing cost and improving quality. The ability of an appliance manufacturer 14A to develop a means by which to engage thousands of additional persons for the purpose of creating new product innovation without raising costs would be a disruptive competitive advantage for that manufacturer 14A. However, because only highly trained and specialized engineers can successfully and properly create appliance control functionality, previous attempts by manufacturers 14A to engage the thousands of additional persons in an uncontrolled manner have not resulted in the production of functional and properly-engineered appliance control functionality. As appliance control functionality plays a critical role in a person's everyday life, such as by affecting the clothes people wear, the food they eat, and the air they breathe, proper implementation of appliance control functionality is a necessity. Many appliance control functionalities are also potentially dangerous and must be precisely managed by the specialized and intricately engineered appliance control system, such as appliance control functionalities associated with high voltage sources, high heat sources, gases, liquids, and chemicals.

[0114] The use of constraints to constrain the appliance development toolkit 10 enables the thousands of additional persons to create content 20 that effects and/or the cycle of operation or the user interaction of an appliance by providing guidelines and rules for innovation. In particular, the constraints can enable users 14 to create content 20 that effects/affects only certain appliance control functionalities deemed appropriate for manipulation by the manufacturer 14A while preventing users 14 from creating content 20 that effects/affects the appliance control functionalities associated with critical systems and components of the appliance 12. This enables the manufacturer 14A to ensure that the appliance 12 is safe for use by maintaining the integrity of the core appliance control functionalities. For example, the manufacturer 14A would constrain the toolkit 10 so as to prevent users 14 from manipulating precision controls, such as those for high heat, electricity, or harmful substances, so that the food, clothing, air, or other article or elements is properly operated upon by the appliance 12.

[0115] As shown in FIG. 26, there are three approaches to providing a constrained appliance development toolkit 10. They are through a constraining model 40, a constraining model instance 42, and hard-coded constraints, which can comprise content 20 as previously described. Constraints define at least a portion of the functionality of the constrained appliance development toolkit 10. It is generally the model instance editor 32 of the system configurator 28 which uses

the constraints to partially limit and partially control the functionality and therefore the content 20 which the system configurator 28 is able to create.

[0116] As shown in FIG. 28 and in FIGS. 7 and 8, appliance control functionality can be created from content 20 generated from an appliance development toolkit 10. This is also shown in FIG. 25 via first content 20 and second content 20 created by the appliance manufacturer 14A and a user 14 respectively.

[0117] Referring back to FIG. 25, the appliance manufacturer 14A may provide a constrained development toolkit 10 which is hard-coded. The appliance manufacturer 14A can also use an unconstrained toolkit 10 to create the third content 20, which can include a constraining model 40, a constraining model instance 42, or both. In the latter two cases, the constrained appliance development toolkit 10 uses the third content 20 to define at least a portion of the constraints.

[0118] Referring back to FIG. 26, it is generally the model instance editor 32 of the system configurator 28 which uses the constraints to partially limit and partially control the functionality and therefore the content 20 which the system configurator 28 is able to create. The message data payload 150 instance may have been created by an unconstrained model instance editor 32 or by a constrained model instance editor 32. The system configurator 28 of the appliance development toolkit 10 (unconstrained and constrained) is able to load multiple model instance 42 files in model instance editors 32 for the creation of and associations between objects.

[0119] A constrained model instance editor 32 constrained by hard-code is shown in FIG. 26. This approach can achieve the same results as the other two approaches, but at a higher development cost over time because each new model 40 or each new model instance 42 interaction needs to be hard-coded. The previous two approaches rely on a data driven approach with its lower cost over time.

[0120] FIG. 27 includes an illustration of using a constraining model instance 42. On the right side of the model instance editor is a sequence model instance for a cycle 42B for a washing machine. The model instance editor 32 is being used to create a custom cycle with the sequence model instance for a cycle. As shown, the custom cycle includes a transition from the idle state to the fill tub state wherein the action object for the fill tub state is responsible for the exact control actions to be taken when the fill tub state is entered. In an unconstrained toolkit 10, the user 14 can specify any control action from the universe of control actions as the action to be taken in the fill tub state. However, the constrained toolkit 10 includes an message data payload model instance 42D which provides a set of control actions less than the universe of control actions such that the user can associate at least one command from the message data payload model instance 42D with the fill tub action object of the sequence model instance for a cycle 42B in order to define the control action to be taken when the fill tub state is entered. Note that the level limit on the fill level message element 156 is between 20 and 80%. This prevents the user 14 from specifying a value for fill level either above 80% or below 20%.

[0121] FIG. 28 depicts the appliance development toolkit 10 interacting with an appliance 12 via its appliance software framework 104 by way of content 20 created by the toolkit. In this embodiment, the content 20 is created by one or more model instance converters 34 and includes a builder file 190 and a plurality of resources 192, which can comprise one or more resources 46. A resource 192 can be a data set contain-

ing data. A resource 192 can be a file or collection thereof, a database, a stream of streaming data, an event source, a network connection for communicating data and the like. In all cases, the nature of the data for a resource 192 ranges from images and videos to XML, relational databases, language conversions, and animation definitions.

[0122] Consumers/users 14 enjoy dynamic user interfaces 64, especially graphical user interfaces 68. Even better are multi-media interfaces that combine audio, visual, and tactile stimuli to create the ultimate user experience. However, users 14 keep their appliances for 10-12 years, and as such it is desirable to provide a variety of user experiences over time to keep the user 14 engaged and excited about the user experience of the appliance 12. The capability to update and transform a multi-media user interface 68 on an appliance 12 is desirable. Themes 194 are collections of resources 192 which can be applied to the components or controls of a multi-media user interface 68 through a mapping at runtime. Themeing is the application of themes 194 to the multi-media user interface 64 at runtime such that that the user interface 64 transforms dynamically in response to the application 50.

[0123] Similarly, the capability to create a very dynamic user experience wherein a plurality of user interface controls or stimuli cause other plurality of user interface stimuli to trigger is desirable. Moreover, an additional feature is to have the different pluralities of user interface stimuli related through a mapping so that when the mapping changes, the user experience also changes. An animation framework 196 includes animation execution software and animation definitions connected to other components of the appliance software framework 104, including properties of the UI controls 62 so that the rendering of the UI controls 62 is affected by the animation execution software operating on the animation definition.

[0124] In both cases of themeing and animations 198, creating associations between resources 192, animations, themes 194, and user interface controls 62 is essential and complex. The appliance development toolkit of FIG. 28 is configured to create the necessary object representations and associations therebetween in order to generate the content 20 necessary for the appliance software framework 104 to build the objects at runtime, including UI controls 62, animation definitions (i.e. objects), data objects from resources, and objects which associate or bind the aforementioned together to achieve the dynamic graphical and multi-media user interface 68 for the appliance 12.

[0125] The main output of the toolkit 10 in this embodiment is a builder file 190. The builder file 190 contains information including object identifiers, object type (class) identifiers, and relationships between identifiers so that a builder 200 in the appliance 12 can read the file at startup or on demand and create the runtime object collections, hierarchies, graphs that control the dynamic graphical and multi-media user interface 68 for the appliance 12. The builder file 190 is generated by a model instance converter 34 that traverses the model instance objects resident in the toolkit 10 memory and exports the builder file 190 content 20 in response. The user interface domain data model instance 42A includes instances of objects from the user interface domain data model 40A, which includes class definitions for pages and user interface controls 62 and the relationship definitions therebetween.

[0126] A view or page 202 contains one or more pages, and a user interface control (UI control) 62 contains one or more

UI controls **62**. Pages are objects that display a plurality of user interface components and are generally designed to be navigated to and navigated from. UI controls **62** are generally reusable templates of components that must be combined with data at runtime to create a useful control. UI controls **62** are things like buttons, knobs, slider bars, select boxes, text boxes, check boxes, image frames, movie frames, input windows, and the like. UI controls **62** have a plurality of properties which are named components of the UI control **62** which either receive or emit data. It is also possible to think of a UI control property as a variable wherein the identifier of the variable would be UI control identifier, property identifier (i.e., UI control identifier, control property identifier). Examples of UI control properties are font, color, style, size, data, shrinkable, hideable, hide, and the like.

[0127] The behavior, rendering, visualization and functionality of a UI control **62** is affected by its properties. UI controls **62** can also emit data which can also be associated with a property. Examples of properties include current data, state **246**, current size, current state of visibility and the like. By connecting or associating UI control properties to representations of variables known as data sources or binding objects **204** at runtime, the UI control **62** is able to be affected by other actors in the appliance software framework **104** and to be effectively rendered. Additionally, the connection to properties is able to affect other actors in the appliance software framework **104** which are connected to or are listening to property values of a UI control **62**. For example, a tactile animation can be listening to a pressed property of a UI control **62** so that when the press property is true, the tactile animation executes. The aforementioned UI controls **62**, their properties, representations of variables, binding and actors objects, and the relationships therebetween are created by the builder **200** in response to the builder file **190**.

[0128] To accomplish both themeing and animations, the appliance development toolkit **10** creates a representational hierarchy of objects which can be exported to the builder file **190** and read by the builder **200** to create the aforementioned runtime objects of the appliance software framework **104**. First the toolkit **10** is configured to create objects representing runtime UI controls **62** and to associate a data source identifier **206** with certain properties of the created UI controls **62** wherein the data source identifier **206** is later associated with a resource identifier **210** to create a first binding map, binding map **1**. Next, a set of resource dictionaries **212** are created each having a plurality of resource identifiers **210** and where each resource identifier **210** is associated with a file identifier **214**, which can comprise an address to a resource **192**. The file identifiers **214** can be in the form of a URI, URL, URN, path, and the like. Different resource dictionaries **212** can contain the same resource identifier **210** associated with a different file identifier **214**, thereby creating the basis for themeing.

[0129] The toolkit **10** can also be configured to enable the user **14** to associate a plurality of theme identifiers **216** each with one or more resource dictionary identifiers **218** in a second binding map, binding map **2**, so that when a theme **194** is selected at runtime, data for application to a property of a UI control **62** can be acquired by finding the address of the data through the use of the information contained in binding map **2**, binding map **1** and the resource dictionary **212**.

[0130] Referring still to FIG. **28**, at runtime, the builder **200** reads the builder file **190** and creates the UI control objects and associates them as shown in FIG. **29** with data sources

204. Binding objects/data sources **204** are created for each unique data source identifier **206** in the builder file **190** and locator objects or resource binding objects **220** are created for each unique resource identifier **210** in the builder file **190**. The binding objects **204** are associated with the properties of the UI control objects according to the builder file **190** and associated with the resource binding objects **220** according to the builder file **190**. The addresses of file identifiers **214** associated with the resource identifiers **210** in the resource dictionaries **212** corresponding to the currently selected theme **194** are set into the resource binding objects **220** so that the resource binding objects **220** can acquire the data from the resources **192** when requested.

[0131] Using this arrangement, a theme manager **222** applies a newly selected theme **194** by creating new resource binding objects **220** and associating them with the appropriate binding objects **204** according to the information in the builder file **190**. In this manner, a user **14** of the toolkit **10** can construct multiple mappings between resource data, UI control properties, data streams, animations, and media files, such that changing a the mappings results in a dynamic transformation to the graphical or multi-media interface **68** of an appliance **12**.

[0132] There can be multiple types of resource binding objects **220**. An SQL binding object will know how to execute SQL against a database found at the address of its associated locator resource binding object **220**. A media binding object may know how to un-marshall a binary media file of a certain type. There can also be binding objects pointing to control system domain data **182** associated with the cycle of operation enabling either the UI control objects and or the animation definitions to interact with the appliance control system **90**, appliance software framework **104**, and cycle of operation.

[0133] A special type of resource **192** is a language resource. By choosing a theme **194**, the graphical user interface **68** can transform between a first and second language. Also because of the many to many relationships between two or more of the theme identifiers **216**, resource dictionaries **212**, and resources identifiers **210** are composable, a theme **194** can have resources **192** supporting a Spanish Christmas, and another theme **194** could have resources **192** supporting a Spanish victory in the soccer World Cup, wherein there can be one resource dictionary **212** for the Spanish language, one for Christmas, and one for Soccer.

[0134] Animations **198** work the same way as do other resources **192**. Animations **198** can have two binding points, an input and output. The output of an animation **198** is a function of its input value determined by its binding and its $f(x)$ function, which can be any mathematical function. The binding to an animation is depicted in FIG. **28** wherein the animation is bound to two data sources **204** in the form of resource binding objects **220**, as well as to an animation binding object. In effect, the animation **198** acts like a resource **192** of FIG. **29** having its input connected to one resource binding object and its output connect to another resource binding object. When the theme manager **222** changes themed animations **198**, it creates two new resource binding objects, sets an address of the new animation definitions (either input or output) into each of the new resource binding objects, and optionally loads the animation **198** into memory for execution.

[0135] Additionally, the toolkit **10** can construct resources **192** for access by the appliance software framework **104**. The

appliance **12** can also have an interface for receiving a new builder file **190** and/or new resources **192** and can either combine or interchange the new and the existing files so that the appliance **12** can be updated over time with new pages **202**, new themes **194**, new animations **198**, and new resources **192**.

[0136] Looking now to FIGS. **30-42**, in a first embodiment, a hierarchy of objects starts with a single root object that we can call "root." The root object has 0 to n children and the children may be of different types (i.e., type 1 and type 2). In turn, the 0 to n children may also have children. Therefore, an object A that is a child of root and has children of B and C is considered to be both a child and a parent and can be referred to either as a child or a parent depending on the context. Except for the root, all objects in a hierarchy are a child and those with children are also parents. The root is a parent unless it has no children.

[0137] The first embodiment is a simple example of an implementation of a hierarchy wherein the parent child relationships are direct relationships. In a direct parent child relationship, the parent includes an identifier identifying each of its children. Therefore, the parent cannot be decoupled from its children because it comprises the identifiers of its children.

[0138] A second embodiment exemplifies an indirect parent child relationship wherein neither the parents nor the children include identifiers of the other. Instead, a holder object contains the identifiers of both. For example, object Q is a holder and contains an identifier of object A, object B, and object C, wherein object A is of type 1, object B is of type 2 and object C is of type 3. Objects A, B, and C do not have access to the identifiers of one another. The primary responsibility of object Q is to contain identifiers for objects A, B, and C thereby establishing that there is some type of relationship between objects A, B, and C. There are a number of ways that the nature of the relationship between A, B, and C can be ascertained. In a first example, object Q has access to information defining the possible relationships between objects of type 1, 2, and 3. In this example the information would define a first relationship definition between objects of type 1 and type 2 as being a parent-child relationship wherein type 1 must be the parent and type 2 must be the child. The information would also define a second relationship definition between objects of type 1 and objects of type 3 as being a parent-child relationship wherein type 1 must be the parent and type 3 must be the child. With the information, object Q can interpret the relationship between object A, B, and C as a parent with two children wherein A is the parent of children B and C.

[0139] A third embodiment exemplifies an alternate approach for creating an indirect parent child relationship wherein neither the parents nor the children include identifiers of the other. In this embodiment, multiple holders are used to create a holder hierarchy. For example, object Q is a holder and contains an identifier for object A. Object Q also contains an identifier for a second holder object X. Object X contains an identifier for object B. Holder object Q is a parent holder with respect to holder object X because holder object Q contains the identifier to holder object X. Therefore the relationship between object A and object B can be inferred as a parent child relationship when observed from the perspective of holder object Q and holder object X because holder

object Q are in a direct parent child relationship. In this case, object A and object B are in an indirect parent-child relationship.

[0140] A forking element includes a hierarchy having a first parent object with at least two children where at least one of the two children has one or more second children and where the one or more second children have one or more third children. An interpreter of the first parent, the one of the two children, the one or more second children, and the one or more third children interprets the two children as valid values of the parent and interprets that the one or more second children is applicable to the hierarchy when the first parent is paired with the at least one of the two children that is the parent of the one or more second children

[0141] FIG. **30** illustrates a set of direct parent child relationships having an example of a forking element as part of a message data payload model instance **42D**. The First Element of Byte **0** has two valid values, First Choice and Second Choice. Second Element is a child of First Choice and Third Element is a child of Second Choice. Given this arrangement, when a message data payload **150** corresponding to the illustrated message data payload model instance **42D** is transmitted on a network as part of a network message, the value of Byte **0** would determine the meaning of Byte **1**. For example, if the useable data transmitted in Byte **0** corresponded to the first portion of useable data associated with First Choice, then an interpreter or user of the network message could ascertain that Byte **1** contained useable data associated with the second portion of the Second Element rather than Third Element.

[0142] In an extension of the first example exemplifying a nested forking element, the Second Element also has two children Third and Forth Choice respectively each having a child Forth and Fifth element respectively. Here an interpreter or user of the network message could ascertain the meaning of Byte **2** by looking at the useable data found in Byte **1** and associating the useable data of Byte **1** with corresponding second portion of Byte **2**. For example if the useable data of Byte **1** corresponded to the useable data of Third Choice, an interpreter could then determine that the meaning of the useable data found in Byte **2** would correspond to the second portion of the Forth Element. A forking element comprising at least one additional forking element creates a nested forking element.

[0143] FIG. **37** shows a plurality of models **40** that form a simplified UML class diagram that includes examples of relationship definitions including both direct and indirect parent child relationships. It should be noted that a UML class diagram defines possible relationships between future instances of objects derived from at least one class definition by depicting an arrangement of relationship definitions used to define relationships between class definitions where the possible relationships are a function of the relationship definitions. A UML class diagram is useful because the arrangement of and relationships between each of the future instances of objects derived from at least one class definition may be verified and or at least partially predicted using the UML diagram.

[0144] Generally, in an appliance runtime environment, variables **230** are identifiers which have an associated value **232** where different actors in the runtime system set the value **232** of the variable **230**. However, FIG. **37** depicts additional possibilities for expanded use of variables **230** and their values **232** and illustrates the benefit of holders.

[0145] In some cases, a variable 230 can have a relationship with a value 232 where, for example, the relationship depicts a request for the variable 230 to be set to the value 232 at a future time. In other cases, a variable 230 could be associated with a plurality of values 232 in order to depict the possible values 232 of a variable 230 at some future time.

[0146] Yet in other cases, as in forking elements within a message data payload 150 or a capabilities definition, values 232 are parents of other variables 230. Relationships like this are useful to express hierarchies of choices 234, variable validation, payload validation, command validation, user interface behavior, etc. For example a hierarchy of choices 234 might have a root of question 1 with choices A and B as children, where choice A has a child of question 2 having choices of C and D as children. This hierarchy could be used to drive a wizard, such as the use and care guide 130, such that the answer to question 1 would dictate if another question would need to be asked. For example, if the answer to question 1 was choice A, then question 2 would need to be asked to get an answer of either choice C or choice D. However, if choice B were the answer of question 1, then no further questions would be necessary. Using this technique, the behavior of the wizard could be controlled by the capability definition and an answer sheet comprising the list of questions asked and the answers given could be validated using the capability definition.

[0147] Looking again at FIG. 37, the previous example illustrated by FIG. 30 can be understood in the context of the message data payload model 40C shown in FIG. 37. Also shown is that components of the message data payload model 40C extend or inherit from class definitions in variable model 40D. A message element 156 can be a variable 232 or it can be a variable holder 236. Also, choices 234 and variable definitions 238 extend a value abstract class 240.

[0148] Using the previous example of FIG. 30 and applying it the model of FIG. 37, a forking can occur when an abstract value 242, such as a choice 234, has a child of a variable 230, like a message element 156, which is shown to be a potential arrangement in that a choice 234 extends an abstract value 242 via abstract value class 240, and that abstract value 242 can have a variable 230 as a child, and that message element 156 extends or is a message element 156. These relationship definitions as shown in the simplified UML class diagram define the possibility to have message elements 156 having children of choices 234 with those choices 234 having children of other message elements 156 as shown in FIG. 30, which shows an instance of the message data payload model 40C of FIG. 37.

[0149] However, it can be undesirable to have direct parent child relationships between variables 230 and their values 232 as shown in FIG. 30 and as allowed by the model 40D of FIG. 37. As shown in FIG. 37, a variable holder 236 can include a reference to a variable 230 and a value 232. In this way, an indirect parent child relationship can be formed as described in the second embodiment exemplifying an indirect parent child relationship (above) and as shown in the first and second occurrences of FIG. 39, where a first holder 236 holds a reference to a first parent variable 230 and a first child value 232 and a second holder 236 holds a reference to the first parent variable 230 and a second child value 232. FIG. 39 shows that by using the first and second holder objects, the first parent variable can participate in two different indirect parent child relationships; one with the first child value 232 and the other with the second child value 232.

[0150] Additionally, as shown in FIG. 37, another embodiment shows how an indirect parent child relationship can be formed. According to the figure, an instance of a variable holder 236 can also include a reference to an instance of an object that derives from the abstract value class 240, which includes value holder 244, value 232, variable definition 238, and choice 234. And an instance of value holder 244 can include a reference to an instance of an object that derives from value abstract class 240. In this way, an indirect parent-child relationship can be formed as described in the third embodiment exemplifying an indirect parent child relationship (above) and as shown in the third and fourth occurrences of the third and second hierarchies in FIG. 40, respectively, where in the third occurrence, a first variable holder has a reference to or holds a first parent variable 230 and has a reference to or holds a second value holder 244 which then has a reference to or holds a first child value 232. In this way an indirect parent child relationship is formed between the first parent variable 230 and the first child value 232 via the direct parent child relationship between the first variable holder 236 and the second value holder 244. Likewise in the 2nd hierarchy, the first parent variable 230 is shown for a fourth time in the fourth occurrence (first and second occurrences from FIG. 39) in a similar indirect parent child relationship as is shown in the third hierarchy but with a second child value 232. FIG. 40 illustrates a variable 230 participating in two indirect parent child relationships where each relationship involves a different child by using variable holders 236 and value holders 244 as prescribed by the variable model 40D of FIG. 37.

[0151] Additionally, as shown in FIG. 37, the value abstract class 240 is defined as having a direct parent child relationship with variable holders 236 or variable 230. This is the enabling model relationship definition that supports the forking element of FIG. 30 as well as the relationship between Value:Wool:4 and Attribute:Delay:Default=0 of FIG. 38.

[0152] FIG. 37 also illustrates the model 40 for the capabilities model 40F of an appliance 12. FIG. 38 illustrates a capabilities model instance 40F comprising a hierarchy of variables 230 to values 232 and variables 230 to variable definitions 238 in repeating direct parent child relationships. This hierarchy known as a capabilities tree is a child of the state 246 object idle, meaning that when the appliance 12 is in an idle state, the hierarchy contained by state object idle represents the operational capabilities of the appliance 12 from a command and control perspective. From the command perspective, all valid commands can be derived by observing and interpreting the hierarchy. A command, in its simplest form, is a message that results in one appliance variable 230 being set to a value 232. The variable 230 and the value 232 together are referred to as a paired element 252 (also shown in FIG. 41). In many cases however, a valid command to an appliance 12 includes a plurality of interdependent variables 230 each having a value 232 selected from a plurality of valid values 232 and wherein the selection of the values 232 determines a portion of the other interdependent variables 230 that also must be specified with a value 232 to form a well formed command or command container 250.

[0153] As previously described in the hierarchy of choices 234 example, the appliance capabilities model 40F can be used to determine what additional interdependent variables 230 must be included in a command container 250 based on the selected value 232 of each variable 230. Command containers 250 have at least one paired element 252. A command

container 250 may be validated by traversing the capability tree to observe and verify that each of the variables 230 or variable holders 236 in the command container 250 is one of a root of the tree and a parent in the tree wherein the parent is a value 232 or value holder 244 as part of the plurality of paired elements 252, to observe and verify that each paired element 252 is located at one of the root or a direct descendent of another paired element 252 connected to the root, and to observe and verify that at least one paired element 252 comprises a value 232 or value holder 244 as a leaf node of the tree. As shown in FIGS. 41 and 42, a cycle definition, then, includes a command container 250 wherein the content 20 of the command container 250 affects the cycle of operation of the appliance 12 when the appliance 12 runtime sets the variables 230 specified by the command container 250 to the values 232 specified in the command container 250. Other information included in the cycle definition can be used for graphical user interface 68 rendering and other non-control system domain purposes.

[0154] The capabilities model instance 42F of FIG. 38 is an example of using only direct parent child relationships between variables 230 and values 232. However, according to FIG. 37, a different embodiment using variable holders 236 and value holders 244 can be constructed (similar to FIG. 40) where the capabilities model instance 42F would comprise variable holders 236, variables 230, value holders 244, and values 232.

[0155] It is apparent, by observing FIG. 38, how value holders 244 and variable holders 236 could provide improvement to the compatibility of the two model instances 42D, 42F. Just as in FIG. 37, the variable model 40D provides some common base classes for use by the message data payload model 40C and the capabilities model 40, Content 20 includes variables 230 and values 232 arranged in a nested repeating hierarchy of alternate levels of variables 230 having values 232 and value having variables 230. However, because direct parent child relationships are used in the model instances 42D, 42F, herein referred to as scenario 1, there is less reuse than could be accomplished if variable holder 236 and/or value holders 244 were used as in scenario 2 and scenario 3 of FIGS. 39 and 40, respectively. Referring the variable 'cycle' in the capabilities model instance 42F and the element 'cycle' in the message data payload model instance 42D, it can be observed that these two information elements are the same logical entity. In both cases, the elements refer to the memory variable 230 in the appliance runtime which corresponds to one of the selected, request, and active cycle of the appliance 12. However, the capabilities model instance 42F contains a complete validation hierarchy as exemplified by the 'Delay' variable 230 underneath the 'Wool' value 232. By contrast, the message data payload model instance 42D on the right has two hierarchies, one for the 'cycle' and one for the 'Delay' because the designer of this context made a choice to arrange the information into separate hierarchies. Therefore, because the information is in multiple hierarchies and is partitioned and organized differently, the information must be duplicated in separate information elements as shown in Scenario 1.

[0156] However, if the information were created using the previously described technique of Scenario 3 of FIG. 40, the information would not require duplication and the information elements or identifiers thereof (i.e. variables 230, values 232, message elements 156, choices 234, variable definitions 238, etc.) could be re-used throughout multiple hierarchies each have a different context. Using this approach then, the

multiple contexts can leverage information from the multiple contexts because there are common or shared objects within those contexts which can be used to gather information across multiple contexts by using the shared objects as navigation objects for jumping from and jumping to different contexts. This is further explained and exemplified by FIG. 40 and the description thereof.

[0157] For example, an appliance 12 can communicate its operational capabilities to a client by sending a capabilities model instance 42F to the client. The client can then form a command container 250 and send that command container 250 back to the appliance 12. The appliance 12 can take the variables 230 from the paired elements 252 of the command container 250 and validate the command container 250 by traversing the capabilities tree as previously described. Once validated, the appliance 12 can automatically convert the command container 250 into one or more message data payloads 150 for constructing network messages to execute the command container 250 across multiple control boards communicating on the communications network 18. This automatic conversion and validation is enabled by using variable holders 236 and value holders 244 to construct the capabilities and message data payload model instances, 42F and 42D, respectively.

[0158] When variables 230 and values 232 participate in more than one hierarchy, wherein each hierarchy has a context different from the other hierarchies, it is difficult to only use direct parent child relationships. For this reason, the UML class diagram of FIG. 37 depicts a variable model 40D wherein a user 14 can use either of the at least one variable holder 236 and the at least one value holder 244 in creating at least one hierarchy of elements for content 20 independent of any relationship that may otherwise exist between the variable 230 and other elements and between the value 232 and other elements so that the variable 230 and the value 232 can be used in different contexts with different relationships while maintaining their relationship with each other via the at least one variable holder 236 and the at least one value holder 244.

[0159] FIG. 42 depicts the use of an appliance development toolkit 10 a first set of constraints creating a first set of content 20 with which a second user 14 using an appliance development toolkit 10 having a second set of constraints could use to create a cycle definition 262. As previously described a cycle definition 262 includes a command container 250 with at least one pair element 252 derived from a collection of appliance variables 230 and values 232. The appliance namespace includes a collection of uniquely identifiable and meaningful variables 230 for an appliance 12. Therefore the user 14 of the toolkit 10 with the second set of constraints could create a cycle definition 262 by selecting data from the appliance model instance 42J shown in FIG. 42, which comprises a plurality of model instances 42 used by the appliance 12, and specifically from the appliance namespace 260. As the user 14 constructs the cycle definition 262, the toolkit 10 can validate the cycle definition 262 using the capabilities model instance 42F. The user 14 can associate data about the cycle definition 262 including source identification domain data 186 which includes brand emblems and other licensable data or other data including usage text, help, and one or more identifiers of persons, consumables, and articles, and the like.

[0160] FIG. 43 illustrates the use of a document model instance 42G within a domain model instance 42H interacting with a converter 34 to create content 20 for display in a viewer

38. The purpose of a document model (not shown) is to enable a user **14** to use the model instance editor **32** to create and view content **20** associated with a domain model instance **42H** within the system configurator **28** before final export to a content target **22**. In a sense, the viewer **38** is a content target simulator **52**.

[0161] A domain model (not shown) is an abstraction or model **40** associated with real world constructs like cars, buildings, trees, law, language, media, finance, and just about any topical concept imaginable without respect to non-domain concerns like formatting, language, style, persistence form and the like.

[0162] In FIG. **43** the domain model instance **42H** is an ingredient substitution model and the non-domain model instance is the contained document model instance **42G** shown in the dashed box. As shown, the document model instance **42G** is an arrangement of objects (shown under the UIText object) including markup objects for formatting, special objects for creating spaces or punctuation, text objects for creating static content **20**, and domain objects able to contribute content **20** based on their properties, functionality, and composition.

[0163] A converter **34** traverses the arrangement to create html content **20** for the internet browser based viewer **38** on the right. In this way, a user **14** can specify the behavior of the content target **22** with respect to the content **20** by creating data for simulation of the content target **22**. Additionally, viewing the content **20** aids the user **14** in understanding the meaning of the domain model **40H** in that a portion of the viewable content **20** is a function of the domain model **40H**. Therefore the content **20** and viewer **38** together help the user **14** validate and verify the composition of the domain model **40H**.

[0164] FIG. **44** depicts binding between appliance user domain data **180** and appliance control system domain data **182**. As shown, a cycle outcome model instance **42I** for cooking comprising a food identifier, a vessel identifier and a doneness identifier is bound to a cycle structure **80** identified by SCF5 wherein when the content **20** is generated for the appliance **12** from the cycle outcome model instance **42I** and the sequence model instance for a cycle **42B**, and appliance control functionality of FIG. **8** is created by the appliance software framework **104** of FIG. **7** and FIG. **28**. A user **14** can affect the cycle of operation by selecting elements of the user interface domain data **184** rendered on the user interface **68** and bound to the cycle structure **80** identified by SCF5.

[0165] In this way, the graphical user interface **68** of FIG. **46** can display the source identification domain data **186** and other data on the user interface **64** of the appliance **12** in response to the identifiers either sensed from a sensor like a scanner or selected via the appliance user interface **64**. Moreover, as previously discussed, the cycle definition **262** can be automatically translated into transmittable network messages **266** by a message generator **264** of FIG. **45** using the message data payload model instance **42D** of FIG. **42** and FIG. **45**.

[0166] FIG. **47** shows an example of how an appliance development toolkit **10** according to the invention is used in interaction with a user **14** and an appliance **12** to diagnose an appliance **12**. It further shows additional examples of the use of a constrained toolkit **10** using model instances **42** as the constraining component. The toolkit **10** is configured to create one or more test scripts **270** having at least two steps, each step being separated from its adjacent steps by a transition condition that includes a logic expression resolvable to a

Boolean transition value, at least one command statement associated with one of the at least two steps that instructs what should happen when the at least one step is the current step so that a test engine can execute the at least one command statement contemporaneous with the transition of the at least one step from the current step to the next step. The toolkit **10** also provides information associated with at least one message element **156** in a message data payload **50** so that the message data payload **50** is uniquely identifiable within a universe of pre-defined message data payloads **50** for the appliance **12**. (See the foregoing discussion of identifiers.) A converter **34** will place the test script **270** into a form to be readable or at least useable in diagnosing an appliance **12**.

[0167] There will be associations of command statements and message elements **156** created by the toolkit **10** so that a test engine application **50A** can create a command container **250** based on the test script. Command statements will include such things as questions to a user such as shown in FIGS. **11-15**. Holders **236**, **244** as discussed elsewhere are useful tools for the editor **10** to effect flexibility in creating command sequences for the test script **270**. The test engine application **50A** is configured to observe subsequent network messages **266** and relate those to a transition logic in the test script **270**, and to evaluate the logic for transition to the next step as it traverses a hierarchy in the test script **270**.

[0168] In one embodiment, a second a communications driver can be configured to establish a communication link with the test engine application **50A**, and a fault tree tool application **50B** is configured to access one or more fault trees **110** to construct a command container **250** on instructions in the fault tree(s) **110** and to convey the command container **250** to the test engine application **50A** via the second communication link during execution of a command statement in the fault tree **110**.

[0169] So it can be seen that a model instance editor **32** can use the message data payload model instance **42D** to create the data that a model instance editor **32** uses, along with a sequence model instance for tests **42K**, to create the test script (which is a sequence model instance variant). The test engine application **50A** uses the test script **270** in communication with a smart coupler **56**, such as a smart cable, to communicate with the appliance **12** and with the user **14**. Meanwhile a model instance editor **32** uses a sequence model instance for a fault tree **42C** to create a sequence model instance variant, such as a fault tree, that a fault tree tool application **50B** uses in interaction with the user **14**.

[0170] A sequence model instance for tests **42K** is similar to other instances using the sequence model **40B** in that it allows the user **14** to create a set of steps separated by transition conditions having logic to drive the condition where each step has an associated action specifying the tasks to be done in that step. A sequence model instance for tests **42K** can use message data payload model instances **42D** as constraining elements for the actions in each step. This is accomplished in a similar fashion previously described for FIG. **27** wherein the message data payload model instance **42D** is used to constrain a sequence model instance for a cycle **42B**.

[0171] Referring back to FIG. **47**, the sequence model instance for a fault tree **42C** is constrained as well using the sequence model instance for tests **42K** wherein each test in the sequence model instance for tests **42K** might have an identifier or an identifying test object that can be bound to the action of a step in the sequence model instance for a fault tree **42C** at tool time such that when the fault tree tool application

50B reaches a step wherein a test script 270 should be executed, it can communicate with the test engine application 50A to invoke the test script 270 corresponding to the identification of the test object at runtime.

[0172] The test engine application 50A, having been previously constrained by elements from the message data payload model instance 42D and having actions of steps bound to message data payload model instances 42D can use the binding to automatically construct and transmit useable messages 266 from the test engine application 50A to the appliance 12 using the method as previously described for cycle definition 262 translation to message data payloads 150.

[0173] FIGS. 48, 48A, and 48B illustrate binding between multiple instances of user domain data 180 to control system domain data 182, which is illustrated at a high level in FIG. 23. The control system domain data 182 comprises a cycle outcome model instance 42I, 42B and a sequence model instance for a cycle 4B that can be used for a cycle structure 80 for a cooking appliance 12. To achieve a desired outcome, a set of cooking profiles (FIG. 44) are created each having multiple components specifying various parameters associated with the cooking cycle.

[0174] To get the doneness of crispy donuts, the profiles in FIG. 44 indicate that the user 14 needs to use an iron skillet in a 30" cavity, and in the other case we have a glass crock pot in a 27" cavity; thus, a user 14 can cook those donuts differently to achieve the same outcome, and the desired cycle outcome will point to the specific sequence for the cycle. Different profiles and different cycle structures 80 can therefore achieve the same outcome given a set of appliance user domain data 180 elements like the food type, cavity size, and the pan.

[0175] Using the recipe specified by one of the sequence model instance for a recipe with a first set of portions 42L and the sequence model instance for a recipe with a second set of portions 42M, the selection of which is based on the cooking profiles, the user 14 first gets the ingredients. In this example, the user 14 is using the sequence model instance for a recipe with a first set of portions 42L: get 5 ounces of flour, 2 ounces of sugar. The sequence model instance for a recipe with a first set of portions 42L then transitions to the next state 246 called mix. The user 14 then mixes the ingredients and transitions to the next state to cook. The user 14 puts the mix in the pan and forms the dough, gets a pan, places the dough in the donut forms in the pan, and then transitions into state cook, where the user 14 places the pan in the appliance 12 and uses the user interface 46 to select the food pan and doneness to select the cycle.

[0176] The ingredients substitution model 40N and instance 42N thereof are both appliance user domain data 180. For a portion of flour, there is an alternate portion of crushed seaweed, and a substitution object in the ingredients substitution model instance 42N holds the primary and alternate portion and enables a user 14 to substitute one for the other and still complete the desired cooking cycle.

[0177] Likewise, we have a second substitution that shows a substitution between sugar and Splenda. So the arrows between the ingredients and the alternate portions and the substitution window point up to both the sequence model instance for a recipe with a first set of portions 42L and the sequence model instance for a recipe with a second set of portions 42M, and as seen in the sequence model instance for a recipe with a second set of portions 42M, the ingredients automatically changed out the ingredients from 5 ounces of

flour to 60 ounces of crushed seaweed and from 2 ounces of sugar to 4 ounces of Splenda. This relationship between these models/model instances enables the user 14 to fluidly accommodate issues that arise during cooking.

[0178] The alternate portion can also have nutritional information associated therewith so that as sequence model instance for recipes call for certain portion substitutions, the nutritional information is derived from the portions and then compared that to the constraints from the meal planner discussed below, allowing the meal planner to then actually achieve the substitutions based on nutritional constraints.

[0179] As shown in FIG. 48, this ability to transform and suggest a recipe comprises a meal planner that can query other smart agents of information to figure out how to best plan the meal. The meal can also be a combination of multiple recipes, such as a lasagna followed by donuts for dessert. The meal planner will thus query for the participants in the meal, each person's schedules, the profiles of the participants to note food preferences, allergies, diets, and doctor's orders that would create constraints on the meal planner. The meal planner will then use the information garnered from these queries to select either certain recipes or certain ingredients for recipes to conform to the preferences of the people, the schedules of the people, or the nutritional constraints that people might have based on their diets, allergies, etc.

[0180] The other constraint that a meal planner could look at would be an inventory system constraint where an inventory system actually knows the available portions that are in the house and then the meal planner could take that and select recipes or do ingredient substitutions or recipes based on the inventory at hand. It could also populate a shopping list if there were certain things that it highlighted as not being available or being in conflict with a preference of a person or a diet of a person, then it could kind of spit out a shopping list and say to the user of the meal planner, hey, we better get this. And of course it could automate that transaction by having it ordered, delivered, etc.

[0181] While the invention has been specifically described in connection with certain specific embodiments thereof, it is to be understood that this is by way of illustration and not of limitation, and the scope of the appended claims should be construed as broadly as the prior art will permit.

We claim:

1. An appliance development toolkit to enable creation of content to affect operation of a component in an appliance or to affect user interaction with an appliance, the toolkit comprising:

an editor having a first interface element for creating information associated with the content, a second interface element to select an identifier from a namespace having a universe of identifiers, and a third interface element to associate the identifier with the information,

an interactive user interface on which the editor is displayed for use by a developer to observe and modify the creation, selection and association, and

a converter to generate content using the identifier,

wherein the content identified by the identifier can be used by an appliance to affect operation of a component in an appliance or to affect user interaction with an appliance.

2. The appliance development toolkit of claim 1 wherein the identifier represents functionality.

3. The appliance development toolkit of claim 1 further comprising a persistence component for storing one of the creation, the selection, and the association for later retrieval.

4. The appliance development toolkit of claim 1 wherein the identifier has one of a plurality of states including reserved, available, proposed, approved, published, and deprecated.

5. The appliance development toolkit of claim 4 further comprising a viewer for observing at least one of the creation, the selection, the association, and the state of the identifier.

6. The appliance development toolkit of claim 1 further comprising a persistence component for storing at least one of the creation, the selection, the association, and the state of the identifier.

7. The appliance development toolkit of claim 1 wherein the interactive user interface includes viewing component for displaying at least one of the creation, the selection, the association, and the state of the identifier.

8. The appliance development toolkit of claim 1 wherein the content is the information and the converter is configured to export the content to an appliance.

9. The appliance development toolkit of claim 8 wherein the content is at least one of foods, ingredients, measurements, units, resources, resource profile contexts and functionalities, stains, and fabric types.

10. A development toolkit to enable creation of message data for a communications network, the toolkit comprising: an editor having a first interface element for creating message data, a second interface element to allocate an identifier from a namespace having a universe of identifiers, and a third interface element to associate the identifier with the message data for communication in a message over the communications network wherein the allocation is registered at the namespace, and an interactive user interface on which the editor is displayed for use by a developer to observe and modify the allocation and association of the identifier, wherein no other developer can use an identifier that has been allocated and wherein the message data can be uniquely identified.

11. The development toolkit of claim 10 wherein the identifier represents functionality.

12. The development toolkit of claim 10 further comprising a persistence component for storing one of the creation, the selection, and the association for later retrieval.

13. The development toolkit of claim 10 wherein the identifier has one of a plurality of states including reserved, available, proposed, approved, published, and deprecated.

14. The appliance development toolkit of claim 13 wherein the interactive user interface is configured for observing at least one of the creation, the selection, the association, and the state of the identifier.

15. The appliance development toolkit of claim 10 further comprising a persistence component for storing at least one of the creation, the selection, the association, and the state of the identifier.

16. The appliance development toolkit of claim 10 wherein the interactive user interface includes viewing component for displaying at least one of the creation, the selection, the association, and the state of the identifier.

17. The appliance development toolkit of claim 10 wherein the message data is uniquely identifiable using the registration.

18. A method of allocating identifiers from a namespace for an appliance configured to perform a cycle of operation on an article wherein the appliance has a controller, the method comprising:

- providing a system comprising a database a namespace having a universe of identifiers related to the operation of an appliance,
- storing in memory a state of each identifier in the namespace,
- receiving at least one request from a source to change the state of at least one identifier,
- authenticating in the system credentials associated with the source of the at least one request,
- selecting an identifier from the namespace in response to the request, and
- changing in the memory the state of the selected identifier according to the selection in response to the authentication and the selection,
- wherein the state of the selected identifier determines the availability of the identifier for use by the appliance in performing the cycle of operation.

19. The method of claim 18 wherein the receiving step includes two electronic requests initiated simultaneously.

20. The method of claim 18 wherein the state is selected from available, reserved, in use, published, and deprecated.

* * * * *