



(22) Date de dépôt/Filing Date: 2004/07/28

(41) Mise à la disp. pub./Open to Public Insp.: 2006/01/28

(51) Cl.Int./Int.Cl. A61J 7/04 (2006.01)

(71) Demandeur/Applicant:
FEODOROFF, THOMAS J., CA

(72) Inventeur/Inventor:
FEODOROFF, THOMAS J., CA

(74) Agent: HAUGEN, J. JAY

(54) Titre : SYSTEME ET METHODE DE RAPPEL POUR MEDICAMENTS EN PLAQUETTE ALVEOLEE

(54) Title: BLISTER PACK MEDICATION REMINDER SYSTEM AND METHOD

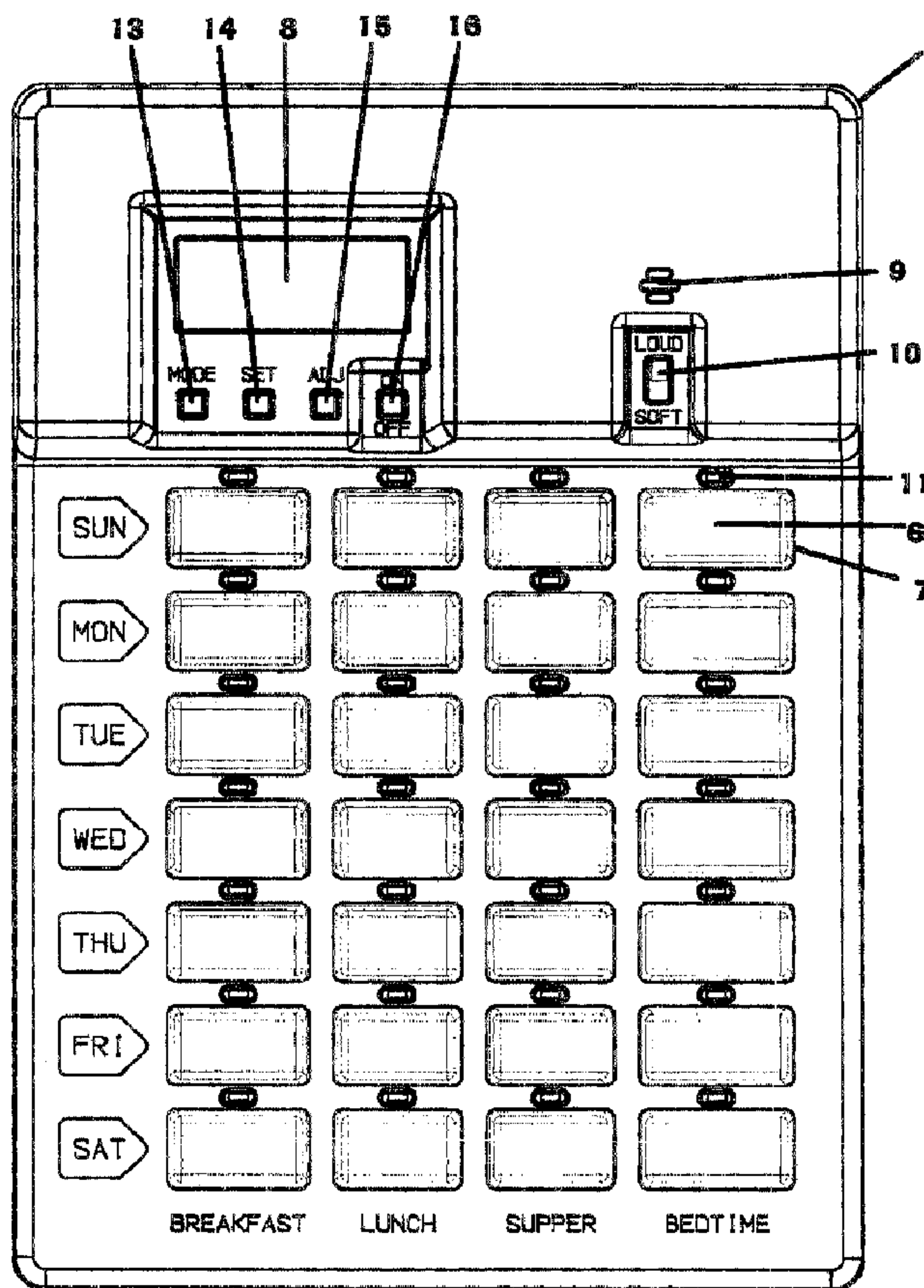

(57) Abrégé/Abstract:

The present invention is a medication reminder system and method for use with blister packs containing medications to be taken by a patient wherein the system alerts the patient when to take the medication contained in a particular blister. An audible alarm and a light indicate which blister is to be opened to remove the medication. The system comprises a case large enough to enclose a

(57) **Abrégé(suite)/Abstract(continued):**

blister pack and has top and bottom halves that are releasably connected together. A circuit board comprising the electronics that operate the system is placed on top of the blister pack and is enclosed in the case along with the blister pack. Both the circuit board and the top case half have openings that allow the blisters of the pack to pass through. Openings on the bottom case half permit the medications in the blisters to be removed. The circuit board is programmable to set the time of an internal clock and to set up to four alarms a day when medications are to be taken. The alarms consist of an audible alarm along with a light flashing by the blister to be expressed by the patient. When the blister pack is depleted, it can be replaced with a new pack without reprogramming the alarm times unless the patient's medical regimen has changed requiring medication to be taken at different times.

1
2
3
4
5
6
7
8
9
10
11
12
13
14
15
16
17

ABSTRACT

The present invention is a medication reminder system and method for use with blister packs containing medications to be taken by a patient wherein the system alerts the patient when to take the medication contained in a particular blister. An audible alarm and a light indicate which blister is to be opened to remove the medication. The system comprises a case large enough to enclose a blister pack and has top and bottom halves that are releasably connected together. A circuit board comprising the electronics that operate the system is placed on top of the blister pack and is enclosed in the case along with the blister pack. Both the circuit board and the top case half have openings that allow the blisters of the pack to pass through. Openings on the bottom case half permit the medications in the blisters to be removed. The circuit board is programmable to set the time of an internal clock and to set up to four alarms a day when medications are to be taken. The alarms consist of an audible alarm along with a light flashing by the blister to be expressed by the patient. When the blister pack is depleted, it can be replaced with a new pack without reprogramming the alarm times unless the patient's medical regimen has changed requiring medication to be taken at different times.

1 **“BLISTER PACK MEDICATION REMINDER SYSTEM AND METHOD”**

2 Inventor – Thomas J. Feodoroff

3 **FIELD OF THE INVENTION**

4 The present invention relates to medication dispensing reminder systems, in
5 particular, reminder systems that work with medications dispensed in blister packs.

6 **BACKGROUND OF THE INVENTION**

7 Medications are often dispensed by pharmacies for patients in blister packs
8 which are prepackaged cards of up to 28 blisters, typically in four column by seven
9 row configuration. Each row represents a day a week whereas each column
10 represents a time during the day “e.g. breakfast, lunch, supper, bedtime” when
11 medication is to be taken. Accordingly, each blister pack represents a week’s worth
12 of medication for a patient. Each blister is, typically, a clear plastic bubble projecting
13 from the blister pack. The pack will have a foil or paper backing whereby depressing
14 the blister from the top will cause the medication to puncture through the rear foil or
15 paper so that the medication is freed from the pack to be taken by the patient.

16 Some patients are forgetful, however, and will lose track of time and not take
17 the appropriate medication at the appropriate time. It is, therefore, desirable to
18 provide a blister pack medication reminder system to alert the patient to take their
19 medication from the appropriate blister at the appropriate time of day.

20 **SUMMARY OF THE INVENTION**

21 The present invention is a medication reminder system and method for use
22 with blister packs containing medications to be taken by a patient. The system
23 includes a case, preferably made of plastic, large enough to enclose a blister pack.
24 The case has top and bottom halves that are releasably connectable together. The top

1 case half has openings, one for each blister on a blister pack to pass through when a
2 blister pack is sandwiched between the top and bottom cases. The system further
3 comprises a circuit board having a microprocessor, a memory, interaction means and
4 alarm means. The circuit board also comprises openings for each blister on a blister
5 pack to pass through and is designed to be placed on top of the blister pack when
6 sandwiched between the top and bottom case halves. A battery cell mounted on the
7 circuit board provides power to the electronics contained thereupon.

8 The memory contains a program code segment operatively connected to the
9 microprocessor whereby the combination of the memory, the program code segment
10 and the microprocessor is adapted to be programmed using the interaction means to
11 set at least one alarm that will indicate when a predetermined blister is to be opened at
12 a predetermined time. As a blister pack will contain up to 28 doses of medication to
13 be taken over a one week period, the system can be programmed to provide up to four
14 alarms a day to alert a patient to take those medications over the one week period.
15 The present invention is programmable such that each of the four alarms can be
16 turned on or off. The time for when each alarm is to be sounded can be programmed.

17 Interaction means are operatively connected to the microprocessor and
18 consists of a display for providing messages to the patient. The interaction means
19 also comprises a series of button-operated switch contacts used to provide input
20 commands for setting the time of an internal clock and for programming the alarm
21 times.

22 The alarm means comprises a speaker used for providing an audible alarm.
23 The alarm means also comprises a light emitting device for each blister on the blister
24 pack. In the preferred embodiment of the present invention, each light emitting

1 device is a light emitting diode (“LED”). Each LED is placed on the circuit board
2 near the blister it is associated with. When it is time to take medication, the LED near
3 the blister to be opened will light visually indicating which blister needs to be opened.
4 The alarm means are operatively connected to the microprocessor and controlled by
5 the microprocessor.

6 To accommodate the interaction means and the alarm means, the top case
7 comprises further openings to allow the display, the buttons and the LEDs to pass
8 through when the system is assembled together so that they are accessible and visible
9 to the patient.

10 The bottom case half is designed to have a plurality of openings, one opening
11 positioned under each blister of the blister pack. These openings permit the removal
12 of medication from the blister by depressing the blister from the top thereby causing
13 the medication to puncture through the rear foil of the blister pack and fall through the
14 opening.

15 When the blister pack has been depleted, the case can be opened to remove the
16 used blister pack and insert a new blister pack. No alarms or settings need to be
17 changed at this time unless the patient’s medication regime has changed.

18 It is an object of the present invention to alert a patient when to take
19 medication from a predetermined blister or a blister pack at a predetermined time.

20 Broadly stated, one aspect of the present invention is a blister pack medication
21 reminder system, comprising a top case having a plurality of openings for allowing a
22 plurality of blisters of a blister pack to pass through, each blister adapted to contain a
23 dose of medication, a bottom case adapted to releasably connect to said top case, said
24 top and bottom cases adapted to receive said blister pack therebetween, a circuit board

1 adapted to be positioned between said top case and said blister pack when said top
2 and bottom cases are releasably connected together, said circuit board comprising a
3 microprocessor and a memory, said memory adapted to contain a program code
4 segment to operate said microprocessor, interaction means for interacting with said
5 reminder system, said interaction means mounted on top of said circuit board and
6 operatively connected to said microprocessor, alarm means for producing an alarm
7 when medication in a predetermined blister is to be taken at a predetermined time,
8 said alarm means operatively connected to said microprocessor, a program code
9 segment operatively contained in said memory, said program code having instructions
10 adapted to operate said microprocessor, the combination of said program code
11 segment, said memory and said microprocessor adapted to be programmed to produce
12 at least one alarm at a predetermined time and to operate said alarm means when said
13 at least one alarm is produced at said predetermined time, and power means for
14 powering said circuit board.

15 Broadly stated, another aspect of the present invention is a method for
16 reminding a user when to take medication from a blister in a blister pack, the method
17 comprising the steps of providing a blister pack medication reminder system, said
18 reminder system adapted to be programmed to provide an alarm indicating when the
19 medication in a predetermined blister is to be taken by said user at a predetermined
20 time, programming said reminder system to produce at least one alarm at a
21 predetermined time, said at least one alarm indicating a predetermined blister of said
22 blister pack to be opened in order to remove the medication contained therein,
23 producing said at least one alarm at said predetermined time, providing an audible
24 alarm when said at least one alarm is produced at said predetermined time, and

1 visually identifying said predetermined blister when said at least one alarm is
2 produced at said predetermined time.

3

4 **BRIEF DESCRIPTION OF THE DRAWINGS**

5 Figure 1 is a top plan view of the present invention with a blister pack
6 inserted.

7 Figure 2 is a perspective exploded view of the present invention showing the
8 top case (2), the circuit board (3), a blister pack (4) and the bottom case (5).

9 Figure 3 is a flowchart describing the logic for setting the current time on the
10 present invention.

11 Figure 4 is a flowchart describing the sub-procedure logic used for setting the
12 current time on the present invention.

13 Figure 5 is a flowchart describing the sub-procedure logic used for setting the
14 minutes for both the current time and alarm time on the present invention.

15 Figure 6 is a flowchart describing the sub-procedure logic used for setting the
16 day of the week for the current time on the present invention.

17 Figure 7 is a flowchart describing the logic used for setting the alarms to on or
18 off and setting the alarm time on the present invention.

19 Figure 8 is a flowchart describing the sub-procedure logic used for setting
20 each of the four alarms to on or off and setting the alarm time for each of the four
21 alarms on the present invention.

22 Figure 9 is a flowchart describing the sub-procedure logic used for setting the
23 alarm time on the present invention.

1 Figure 10 is a flowchart describing the logic used for the present invention to
2 check the alarm times against the current time and activate the alarm if the condition
3 is true.

4 Figure 11 is a flowchart describing the logic used for resetting the alarm once
5 the alarm has become activated on the present invention.

6 DETAILED DESCRIPTION OF THE PREFERRED EMBODIMENT

7 Referring to Figures 1 and 2, Blister Pack Medication Reminder System (1) is
8 comprised of top case (2), circuit board (3), blister pack (4), and bottom case (5).
9 Blisters (6) of blister pack (4) will insert into spaces (7) of top case (2). Display (8)
10 shows the current time and cues when programming. Speaker (9) has loud/soft switch
11 (10) and beeps when the alarm time matches the current time when the system is in
12 operational mode. Light Emitting Diodes (11) centered above each space (7) in
13 system (1) which flash when the alarm time matches the current time to indicate
14 which blister (6) is to be opened. Blister (6) is depressed causing the medication
15 therein to pierce through the rear foil of blister pack (4) and fall through cavity (12) of
16 bottom case (5) in order to retrieve the medication. Located below display (8) are the
17 four buttons: Mode (13), Set (14), Adjust (15) and ON/OFF (16).

18 These buttons are used to set the current time, turn alarms on or off, set alarm
19 times and to turn off an alarm when System (1) is in operation.

20 **Setting Time**

21 Referring to Figure 3, the instructions to set the time are set out in Set_Time
22 Main Program (300). The instructions are as follows:

23 a) Press and hold the "ADJUST" button (15) for a few second until the hours
24 begin to flash.

- 1 b) Press "SET" button (14) until proper hour is flashing.
- 2 c) Press "MODE" button (13) to move to minutes.
- 3 d) Press "SET" button (14) until proper minute is flashing.
- 4 e) Press "MODE" button (13) to set the day of the week.
- 5 f) Press "SET" button (14) until proper day of week indicator is flashing.
- 6 g) Press "ADJUST" button (15) to end procedure.

7 If Adjust button (15) is pressed for more than 3 seconds (step 308), then a
8 listener is activated (step 310). According to this listener, while no other buttons are
9 pressed in a consecutive 20 second time frame (step 312), all attempted setting since
10 the listener was activated will be cancelled (step 332) and display (8) will return to
11 normal running mode showing the current time (step 336). Otherwise, the user will
12 continue to the Set_Time sub-procedure (step 316). Once returning from the
13 Set_Time sub-procedure and the user presses Adjust button (15) (step 320), the
14 changes will be saved (step 324) and display (8) will show the new current time (step
15 328). However, should Adjust button (15) not be pressed within 20 seconds, all
16 attempted settings will be cancelled (step 332) and display (8) will return to normal
17 running mode showing the current time (step 336).

18 When the user is sent to the Set_Time Sub-Procedure (400), illustrated in
19 Figure 4, the Hours on display (8) will flash (step 408) indicating to the user that this
20 setting can now be changed. For every press of Set button (14) (step 412), the hours
21 will increase by one (step 416). Once the hours are set, the user must press Mode
22 button (13) (step 420) to continue to Set_Minutes sub-procedure (step 424). Once the
23 minutes are set, the user must press Mode button (13) (step 428) to continue to
24 Set_Day_of_Week sub-procedure (step 432). Once the day of the week is set, the

1 user will be returned to Setting Time Main Program (step 444). If the user does not
2 press Mode button (13) (step 420) (step 428) within 20 seconds, all attempted settings
3 will be cancelled (step 332) and display (8) will return to normal running mode
4 showing the current time (step 336). Once the time is set, the user will be returned
5 (step 444) to the Set Time Main Program (300).

6 When the user is sent to the Set_Minutes Sub-Procedure (500), illustrated in
7 Figure 5, the Minutes on display (8) will flash (508) indicating to the user that this
8 setting can now be changed. For every press of Set button (14) (step 512), the
9 minutes will increase by one (step 516). Once the minutes are set, the user will be
10 returned (step 520) to the Set Time Sub-Procedure (400).

11 When the user is sent to the Set_Day_of_Week Sub-Procedure (600),
12 illustrated in Figure 6, Light Emitting Diode (11) in first column on the day of week
13 of the current setting will flash (step 608) indicating to the user that this setting can
14 now be changed. For every press of Set button (14) (step 612), Light Emitting Diode
15 (11) will flash on the row representing the next day of the week (step 616). Once the
16 day of the week is set, the user will be returned (step 620) to the Set Time Sub-
17 Procedure (400).

18 **Setting Alarms**

19 The procedure for setting alarms on System (1) are as follows:

- 20 a) Press and hold "MODE" button (13) until "AL 1" (Alarm 1) shows in
21 display (8) alternately with status "SEL" (Select) or "OFF".
- 22 b) Press "ON/OFF" button (16) to turn alarm on or off.
- 23 c) Press "MODE" button (13) and repeat procedure for "AL 2" (Alarm 2),
24 "AL 3" (Alarm 3) and "AL 4" (Alarm 4).

1 d) When "AL 4" (Alarm 4) is displayed, press the "MODE" button (13) to
2 end the procedure.

3 During Setting Alarm Main Procedure (700), illustrated in Figure 7, if Mode
4 button (13) is pressed for more than 3 seconds (step 708), then a listener is activated
5 (step 710). According to this listener, while no other buttons are pressed in a
6 consecutive 20 second time frame (step 712), all attempted setting since the listener
7 was activated will be cancelled (step 728) and display (8) will return to normal
8 running mode showing the current time (step 724). Otherwise, the user will continue
9 to Alarm_Adjust Sub-Procedure (step 716). When the user return from Alarm_Adjust
10 Sub-Procedure 800, illustrated in Figure 8, then the changes are saved (step 720), and
11 display (8) will return to normal running mode showing the current time (step 724).

12 When the user is sent to Alarm_Adjust Sub-Procedure (800), for each of the
13 alarms starting with Alarm 1 (AL1) (step 808), display (8) will show the current alarm
14 being adjusted alternatively with its' status (SEL or OFF) (step 812). If the current
15 alarm's status is SEL (ON) (step 816), then the alarm time will also be displayed
16 alternately (step 820) with the value of the current alarm and its' status. If ON/OFF
17 button (16) is pressed (step 824), then if the current alarm's status is OFF (step 828),
18 it will change it to ON (step 832) and alternately display that alarms' time (step 836),
19 else, it will change it to OFF and alternately display the Alarm number and Status
20 only. If the user is just turning the alarms ON or OFF, then the user needs only to
21 press Mode button (13) (step 856) and increase the alarm by one (step 860). If the
22 Alarm number is no longer in the range from Alarm 1 to Alarm 4 (step 808), then the
23 user is returned (step 868) to Setting Alarms Main Procedure (700).

1 **Setting Alarm Times**

2 Setting the alarm times on System (1) is accomplished as follows:

- 3 a) Press "MODE" button (13) until "AL 1" (Alarm 1) shows in display (8)
- 4 alternately with status "SEL" (Select) or "OFF".
- 5 b) Alarm must be in "SEL" (Select) mode to set the alarm time.
- 6 c) Press the ON/OFF button (16) to change display (8) to "SEL" (Select) if
- 7 needed.
- 8 d) Press and hold the "ADJUST" button (15) for a few seconds until the
- 9 hours begin to flash.
- 10 e) Press "SET" button (14) until proper hour is flashing.
- 11 f) Press "MODE" button (13) to move minutes.
- 12 g) Press "SET" button (14) until proper minute is flashing.
- 13 h) Press "ADJUST" button (15) when proper time is selected.
- 14 i) Repeat process for alarms "AL 2" (Alarm 2), "AL 3" (Alarm 3) and "AL
- 15 4" (Alarm 4) as needed.

16 When setting the Alarm time, if Mode button (13) is pressed for more than 3
17 seconds (step 708), then a listener is activated (step 710). According to this listener,
18 while no other buttons are pressed in a consecutive 20 second time frame (step 712),
19 all attempted settings since the listener was activated will be cancelled (step 728) and
20 display (8) will return to normal running mode showing the current time (step 724).
21 Otherwise, the user will continue to the Alarm_Adjust Sub-Procedure (step 716).
22 When the user returns from the Alarm_Adjust Sub-Procedure (800), then the changes
23 are saved (step 720), and display (8) will return to normal running mode showing the
24 current time (step 724).

1 When the user is sent to the Alarm_Adjust Sub-Procedure (800), for each of
2 the alarms starting with Alarm 1 (AL1) (step 808), display (8) will show the current
3 alarm being adjusted alternately with its' status (SEL or OFF) (step 812). If the
4 current alarm's status is SEL (ON) (step 816), then the alarm time will also be
5 displayed alternately (step 820) with the value of the current alarm and its' status. If
6 ON/OFF button (16) is pressed (step 824), then if the current alarm's status is OFF
7 (step 828), it will change it to ON (step 832) and alternately display that alarms' time
8 (step 836), else, it will change it to OFF and alternately display the Alarm number and
9 Status only. If the Adjust button is pressed for more than 3 seconds, and the Status is
10 equal to ON (step 848), then the user will go through the steps outlined in the
11 Set_Alarm_Time sub-procedure (step 852). If Mode button (13) (step 856) is pressed,
12 then the alarm is increased by one (step 860). If the Alarm number is no longer in the
13 range from Alarm 1 to Alarm 4 (step 808), then the user is returned (step 868) to the
14 setting Alarms Main Procedure (700).

15 When the user is sent to the Set_Alarm_Time Sub-Procedure (900), illustrated
16 in Figure 9, the Hours on display (8) will flash (step 908) indicating to the user that
17 this setting can now be changed. For every press of Set button (14) (step 912), the
18 hours will increase by one (step 916). Once the hours are set, the user must press
19 Mode button (13) (step 920) to continue to the Set_Minutes sub-procedure (step 924).
20 Once the minutes are set, and the user presses Adjust button (15) (step 928), the user
21 will be returned (step 940) to the Alarm Adjust Sub-Procedure (800).

22 Every minute, the system will check if the current time is equal to an alarm
23 time and activate the alarm accordingly as illustrated in Figure 10. A variable called
24 Number is assigned a numeric value from 1 to 4 (step 1008). It will then use this

1 number to check if the current time is equal to one of the 4 alarm times. If an alarm
 2 time equals the current time (step 1012), then a flag is set to True and the column
 3 value is set to the value of the variable Number (1, 2, 3 or 4) (step 1016). The
 4 variable Number is then increased by one (step 1020). Once the variable Number is
 5 greater than 4 (step 1008) then the Flag is checked (step 1024). If the flag is True
 6 (step 1024), then the flag is reset to False (step 1028), the audible alarm is turned on
 7 (step 1032) and Light Emitting Diode (11) at the intersection of the column and the
 8 day of the week is set to flash (step 1036).

9 **Resetting Alarm when System is in Operational Mode**

10 To reset the alarm when System 1 is in operational mode, ON/OFF button (16)
 11 is pressed to turn alarm off.

12 Once an alarm is activated, the user will be able to deactivate the alarm, or
 13 over a period of time, the alarm will sequentially deactivate itself as illustrated in
 14 Figure 11. If the alarm is activated (step 1108), then if the user presses ON/OFF
 15 button (16) (step 1112), audible alarm (9) and Light Emitting Diode (11) are turned
 16 off (step 1116) (step 1120). If ON/OFF button (16) is not pressed (step 1112), then
 17 after one minute of the alarm being active (step 1124), audible alarm (9) will be
 18 turned off by the system (step 1128). If after an hour of the alarm being active (step
 19 1132), then the Light Emitting Diode (11) will be turned off by the system (step
 20 1136).

21 The rows of spaces (7) reflect the days of the week, (Sunday through
 22 Saturday), and the columns of spaces (7) reflect the time of day, (breakfast, lunch,
 23 supper, and bedtime). The software program containing the logistics will determine
 24 which Light Emitting Diode (11) at the intersection of the row and column will be

1 emitted at the specified alarm time indication which blister is to be expressed into
2 cavities (12) of the bottom case.

3 Although a few preferred embodiments have been shown and described, it will
4 be appreciated by those skilled in the art that various changes and modifications might
5 be made without departing from the scope of the invention. The terms and
6 expressions used in the preceding specification have been used herein as terms of
7 description and not of limitation, and there is no intention in the use of such terms and
8 expressions of excluding equivalents of the features shown and described or portions
9 thereof, it being recognized at the scope of the invention as defined and limited only
10 by the claims that follow.

11

1 We claim:

- 2 1. A blister pack medication reminder system, comprising:
- 3 a) a top case having a plurality of openings for allowing a plurality of
4 blisters of a blister pack to pass through, each blister adapted to contain
5 a dose of medication;
- 6 b) a bottom case adapted to releasably connect to said top case, said top
7 and bottom cases adapted to receive said blister pack therebetween;
- 8 c) a circuit board adapted to be positioned between said top case and said
9 blister pack when said top and bottom cases are releasably connected
10 together, said circuit board comprising a microprocessor and a
11 memory, said memory adapted to contain a program code segment to
12 operate said microprocessor;
- 13 d) interaction means for interacting with said reminder system, said
14 interaction means mounted on top of said circuit board and operatively
15 connected to said microprocessor;
- 16 e) alarm means for producing an alarm when medication in a
17 predetermined blister is to be taken at a predetermined time, said alarm
18 means operatively connected to said microprocessor;
- 19 f) a program code segment operatively contained in said memory, said
20 program code having instructions adapted to operate said
21 microprocessor, the combination of said program code segment, said
22 memory and said microprocessor adapted to be programmed to

1 produce at least one alarm at a predetermined time and to operate said
2 alarm means when said at least one alarm is produced at said
3 predetermined time; and

4 g) power means for powering said circuit board.

5 2. The reminder system as set forth in Claim 1 wherein said circuit board
6 comprises an opening for each blister of said blister pack whereupon each
7 blister will pass through said openings in said circuit board to be accessible
8 by said user through the openings in said top case when said top and
9 bottom cases are releasably connected together with said circuit board and
10 said blister pack sandwiched therebetween.

11 3. The reminder system as set forth in Claim 1 wherein said top case further
12 comprises a plurality of openings for said interaction means and said alarm
13 means to be accessible by a user when said top case and said bottom case
14 are releasably connected together with said circuit board and said blister
15 pack sandwiched therebetween.

16 4. The reminder system as set forth in Claim 3 wherein said interaction
17 means comprises:

18 a) a display for displaying messages to the user; and

19 b) at least one button-operated switch contact for programming said
20 combination of said program code segment, said memory and said
21 microprocessor.

- 1 5. The reminder system as set forth in Claim 4 wherein said interaction
2 means comprises four button-operated switch contacts for programming
3 said combination of said program code segment, said memory and said
4 microprocessor.
- 5 6. The reminder system as set forth in Claim 3 wherein said alarm means
6 comprises:
- 7 a) a speaker for providing an audible indication of said alarm; and
- 8 b) visual indication means for visually identifying which blister on said
9 blister pack is to be opened when said alarm is produced.
- 10 7. The reminder system as set forth in Claim 6 wherein said visual indication
11 means comprises a light emitting device for each blister of said blister
12 pack, each of said devices passing through an associated opening in said
13 top case when said top and bottom cases are releasably connected together
14 with said circuit board and said blister pack sandwiched therebetween.
- 15 8. The reminder system as set forth in Claim 7 wherein said light emitting
16 devices are light emitting diodes.
- 17 9. The reminder system as set forth in Claim 2 wherein said bottom case
18 further comprises a plurality of openings, an opening for each of said
19 blisters of said blister pack, each opening located directly under a blister
20 when said top and bottom cases are releasably connected together with
21 said circuit board and said blister pack sandwiched therebetween, whereby
22 the act of depressing a blister from the top forces the medication contained

1 in said blister to puncture through the rear foil of said blister pack and fall
2 through the bottom case opening located beneath said blister.

3 10. The reminder system as set forth in Claim 1 wherein said power means
4 comprises a battery cell operatively attached to said circuit board.

5 11. A method for reminding a user when to take medication from a blister in a
6 blister pack, the method comprising the steps of:

7 a) providing a blister pack medication reminder system, said reminder
8 system adapted to be programmed to provide an alarm indicating when
9 the medication in a predetermined blister is to be taken by said user at
10 a predetermined time;

11 b) programming said reminder system to produce at least one alarm at a
12 predetermined time, said at least one alarm indicating a predetermined
13 blister of said blister pack to be opened in order to remove the
14 medication contained therein;

15 c) producing said at least one alarm at said predetermined time;

16 d) providing an audible alarm when said at least one alarm is produced at
17 said predetermined time; and

18 e) visually identifying said predetermined blister when said at least one
19 alarm is produced at said predetermined time.

1 12. The method as set forth in Claim 11 wherein said reminder system
2 comprises:

3 a) a top case having a plurality of openings for allowing a plurality of
4 blisters of a blister pack to pass through, each blister adapted to contain
5 a dose of medication;

6 b) a bottom case adapted to releasably connect to said top case, said top
7 and bottom cases adapted to receive said blister pack therebetween;

8 c) a circuit board adapted to be positioned between said top case and said
9 blister pack when said top and bottom cases are releasably connected
10 together, said circuit board comprising a microprocessor and a
11 memory, said memory adapted to contain a program code segment to
12 operate said microprocessor;

13 d) interaction means for interacting with said reminder system, said
14 interaction means mounted on top of said circuit board and operatively
15 connected to said microprocessor;

16 e) alarm means for producing an alarm when medication in a
17 predetermined blister is to be taken at a predetermined time, said alarm
18 means operatively connected to said microprocessor;

19 f) a program code segment operatively contained in said memory, said
20 program code having instructions adapted to operate said
21 microprocessor, the combination of said program code segment, said
22 memory and said microprocessor adapted to be programmed to

1 produce at least one alarm at a predetermined time and to operate said
2 alarm means when said at least one alarm is produced at said
3 predetermined time; and

4 g) power means for powering said circuit board.

5

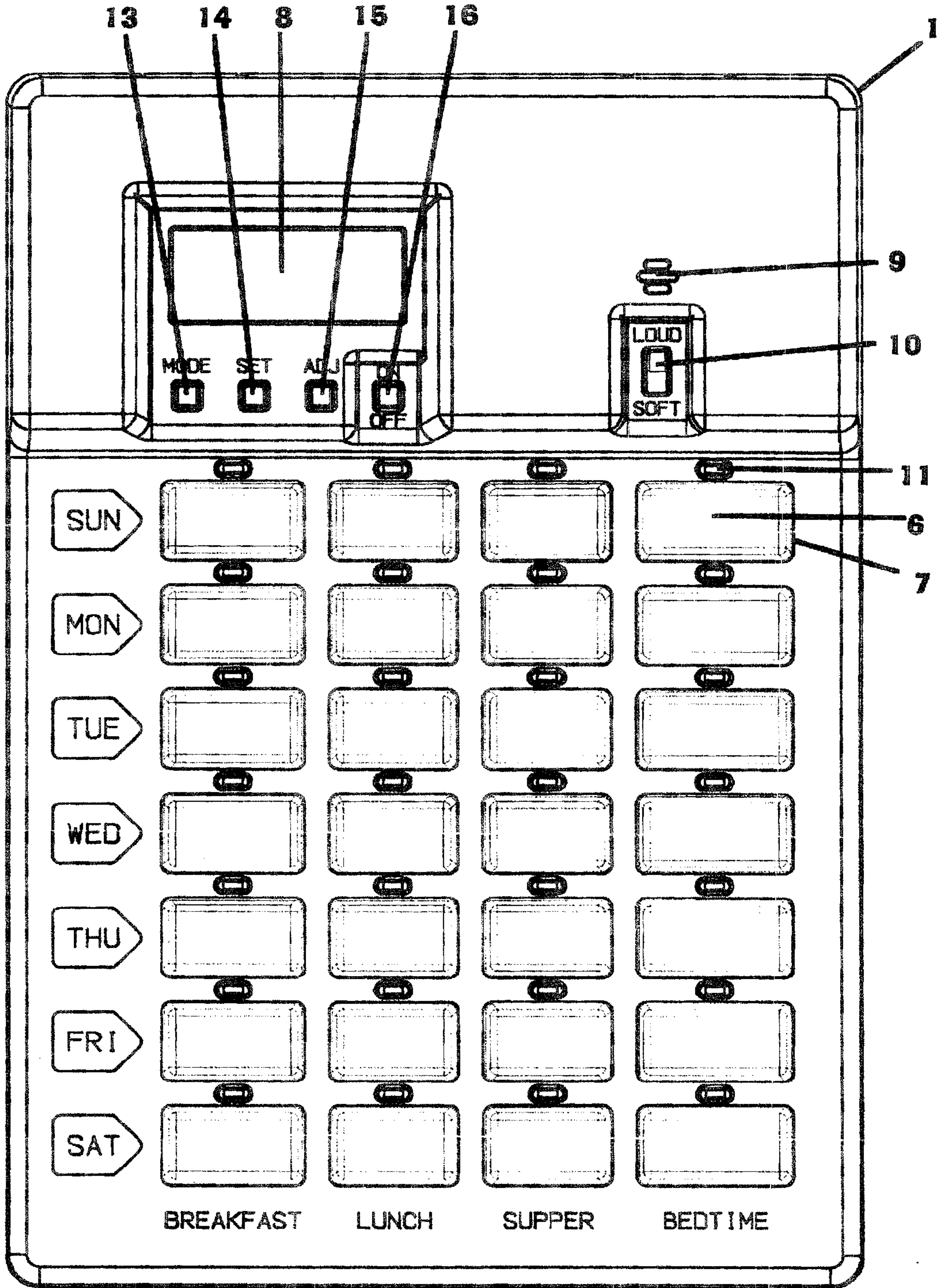

FIG. 1

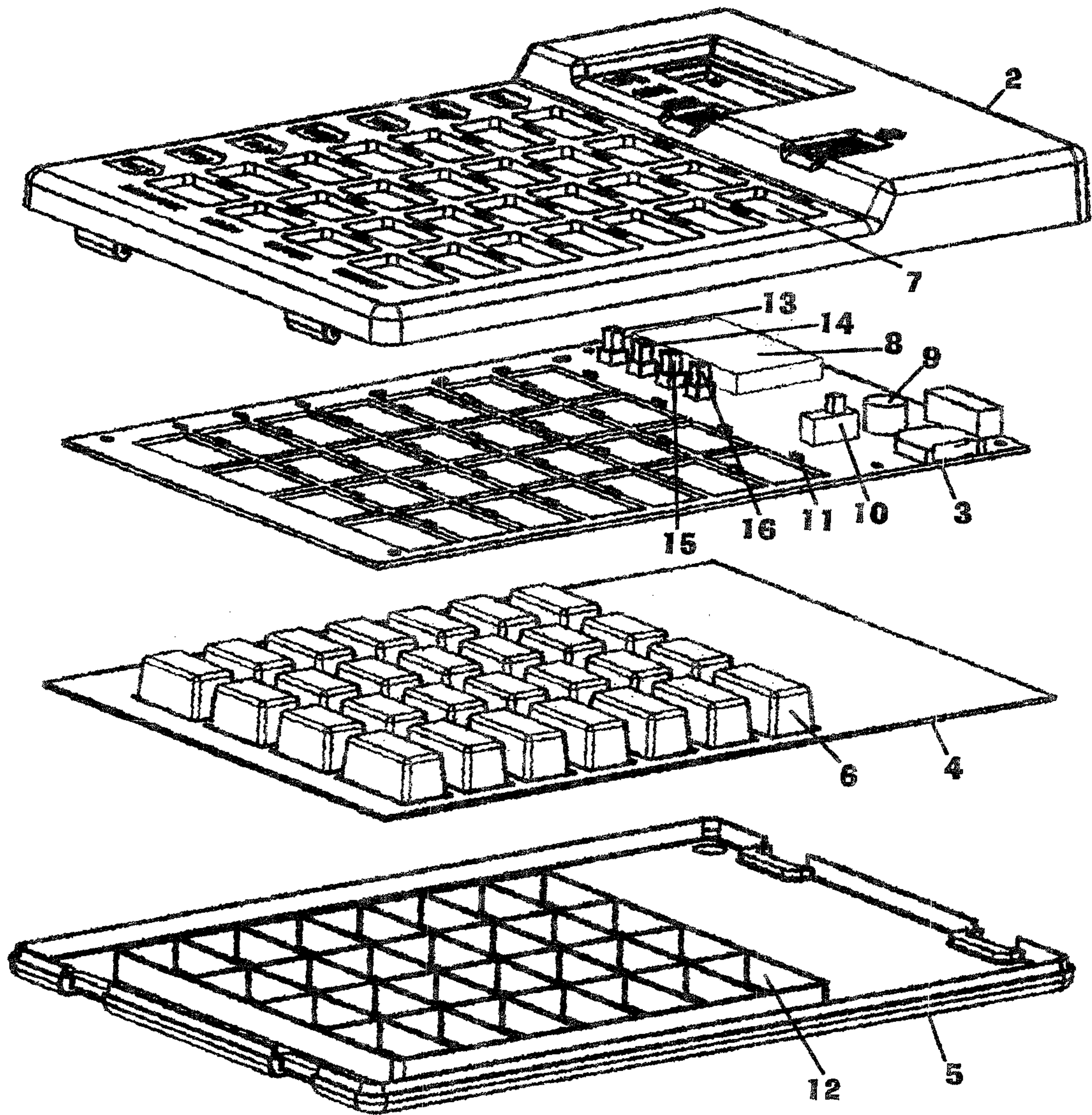

FIG. 2

FIG. 3 Set Time Main Program

300

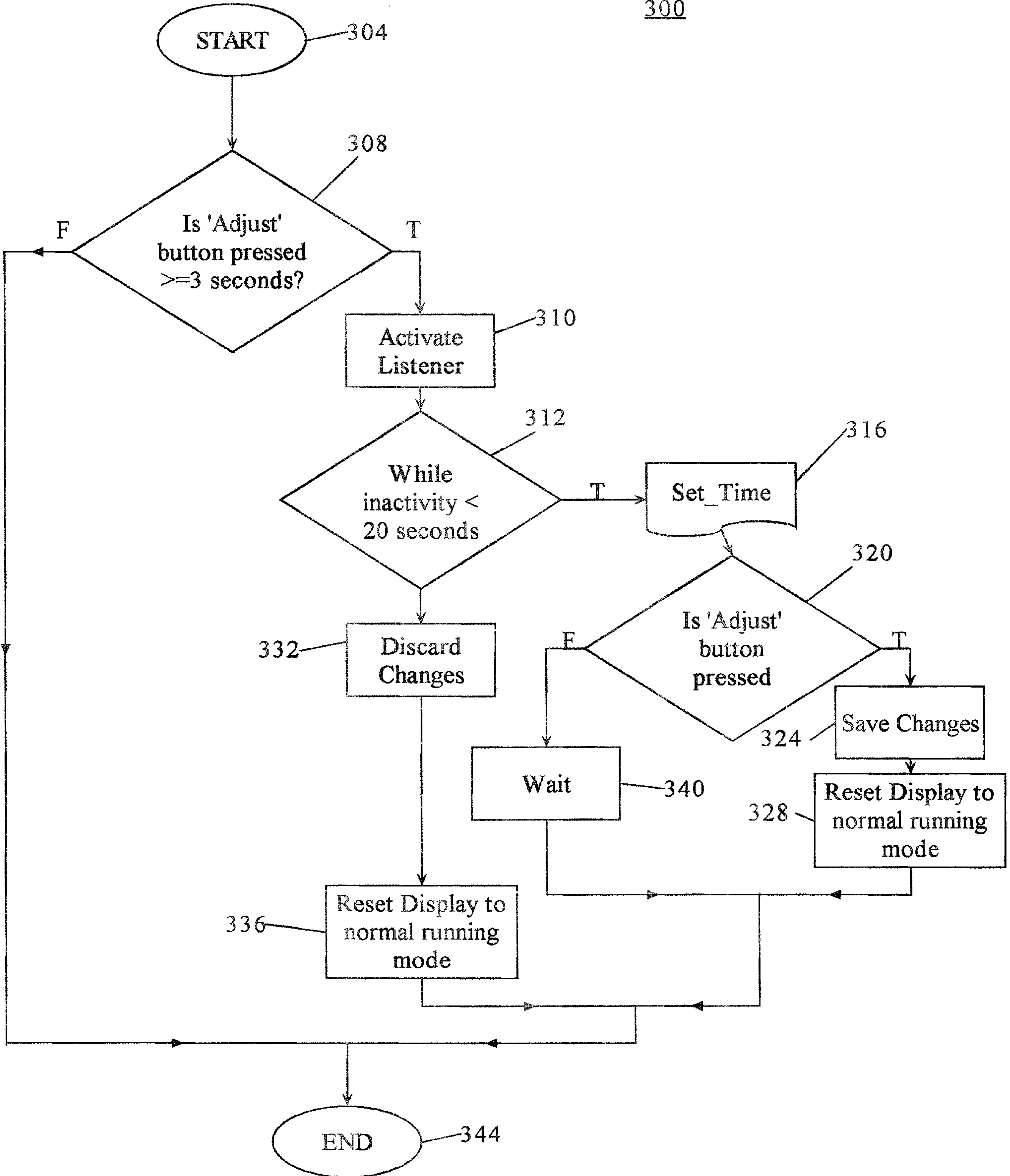

FIG. 4 Set Time Sub-Procedure

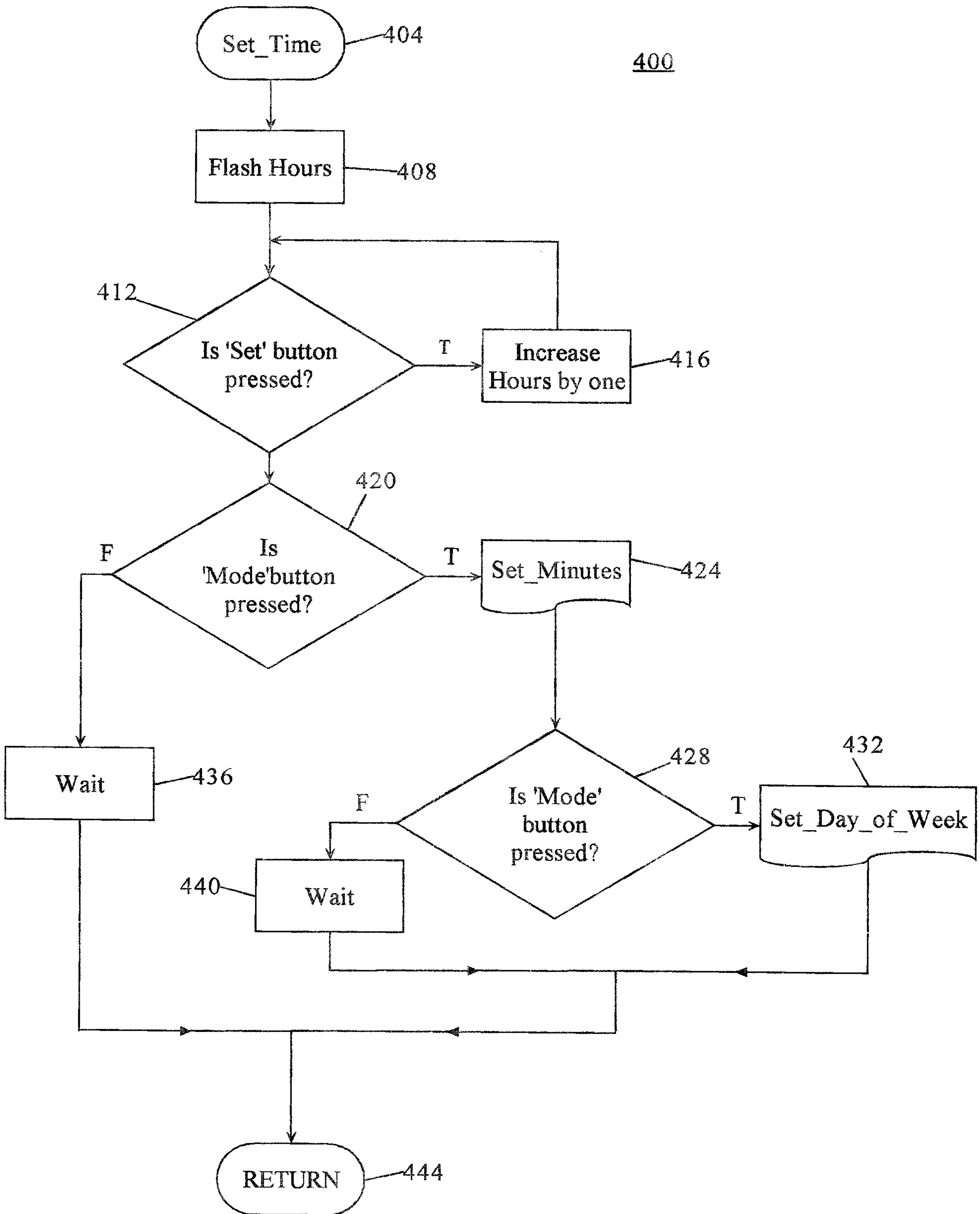

FIG. 5 Set Minutes Sub-Procedure

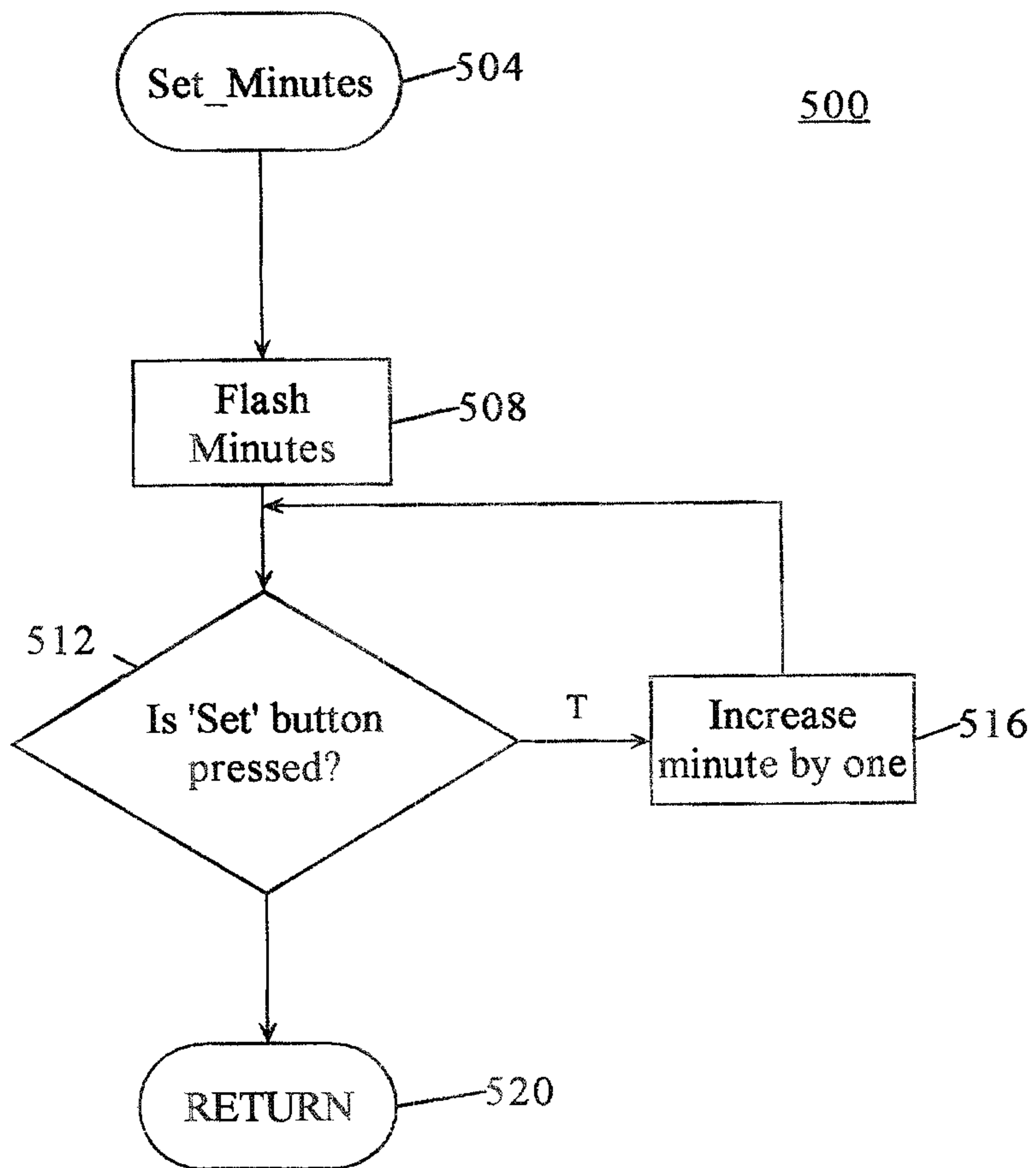

FIG. 6 Set Day of Week Sub-Procedure

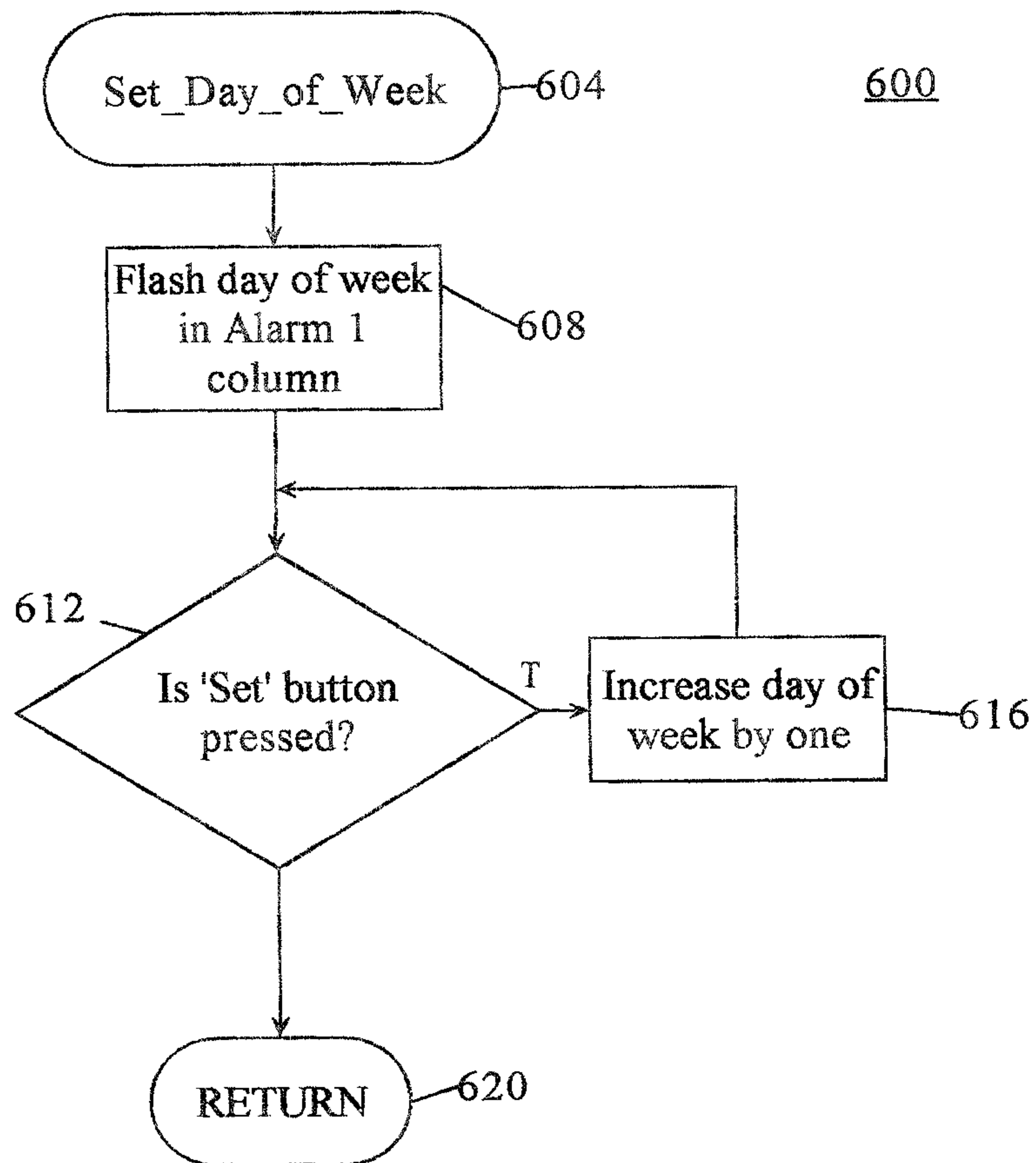

FIG. 7 Setting Alarms Main Procedure

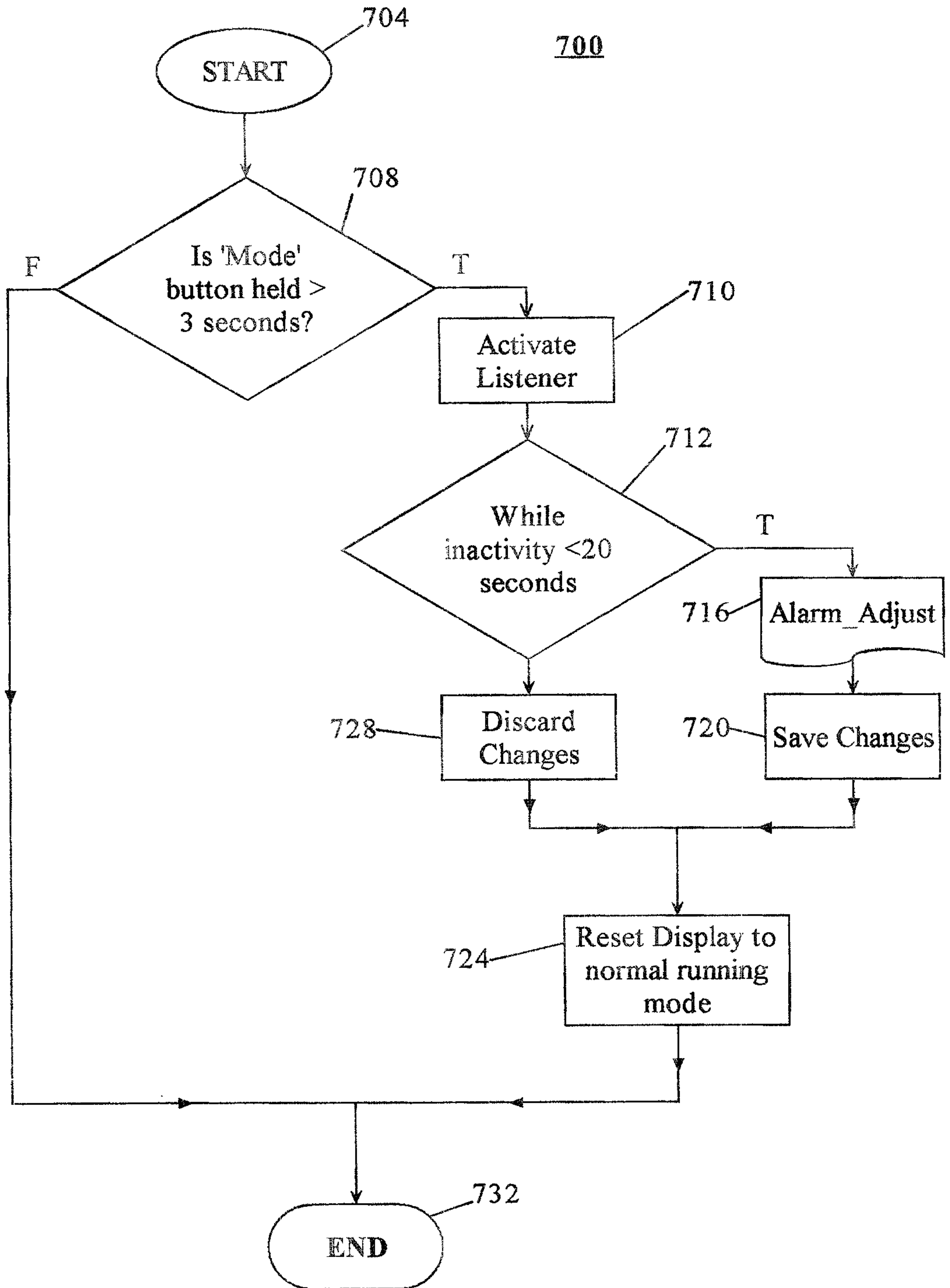

FIG. 8 Alarm Adjust Sub-Procedure
800

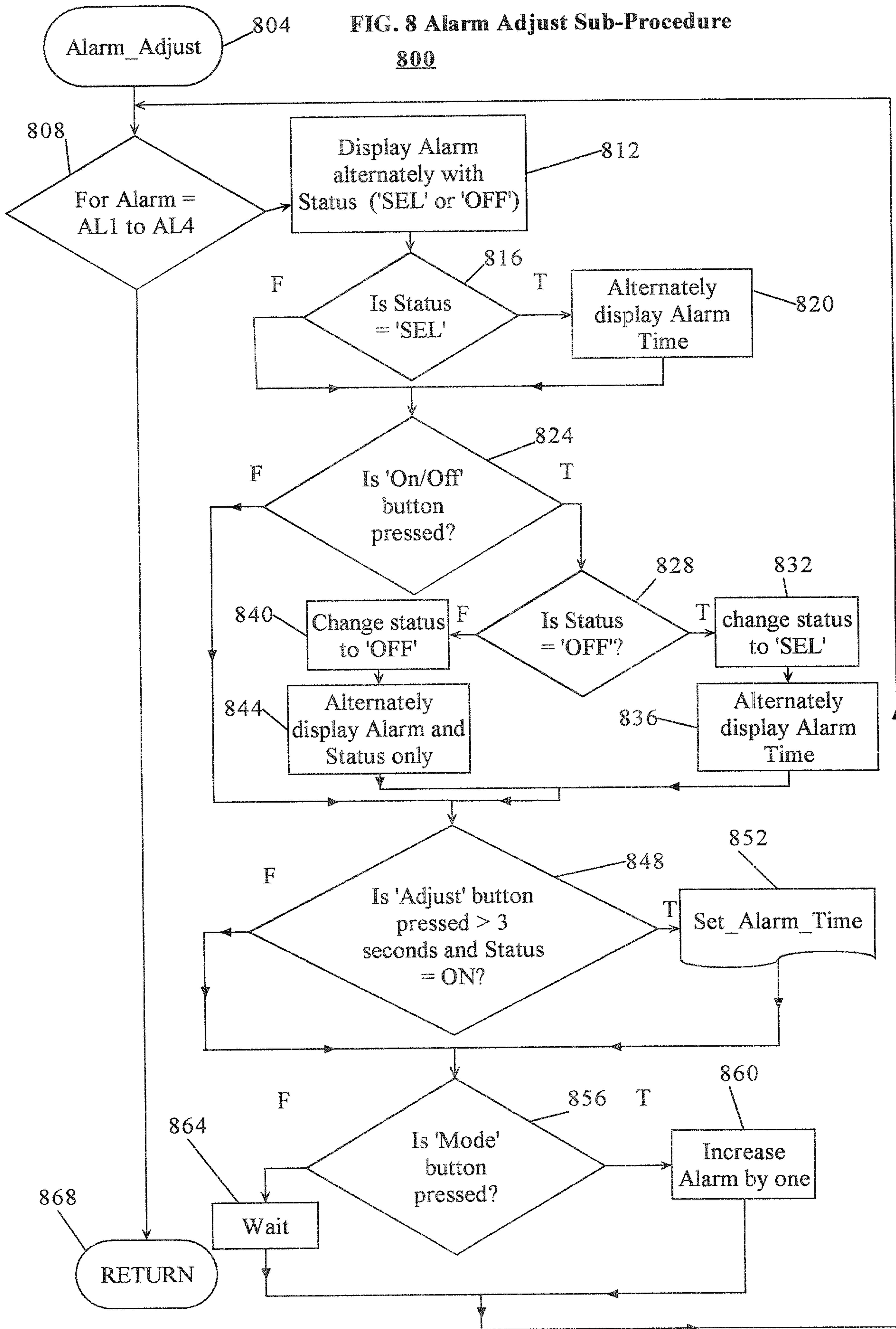

FIG. 9 Setting Alarm Time Sub-Procedure

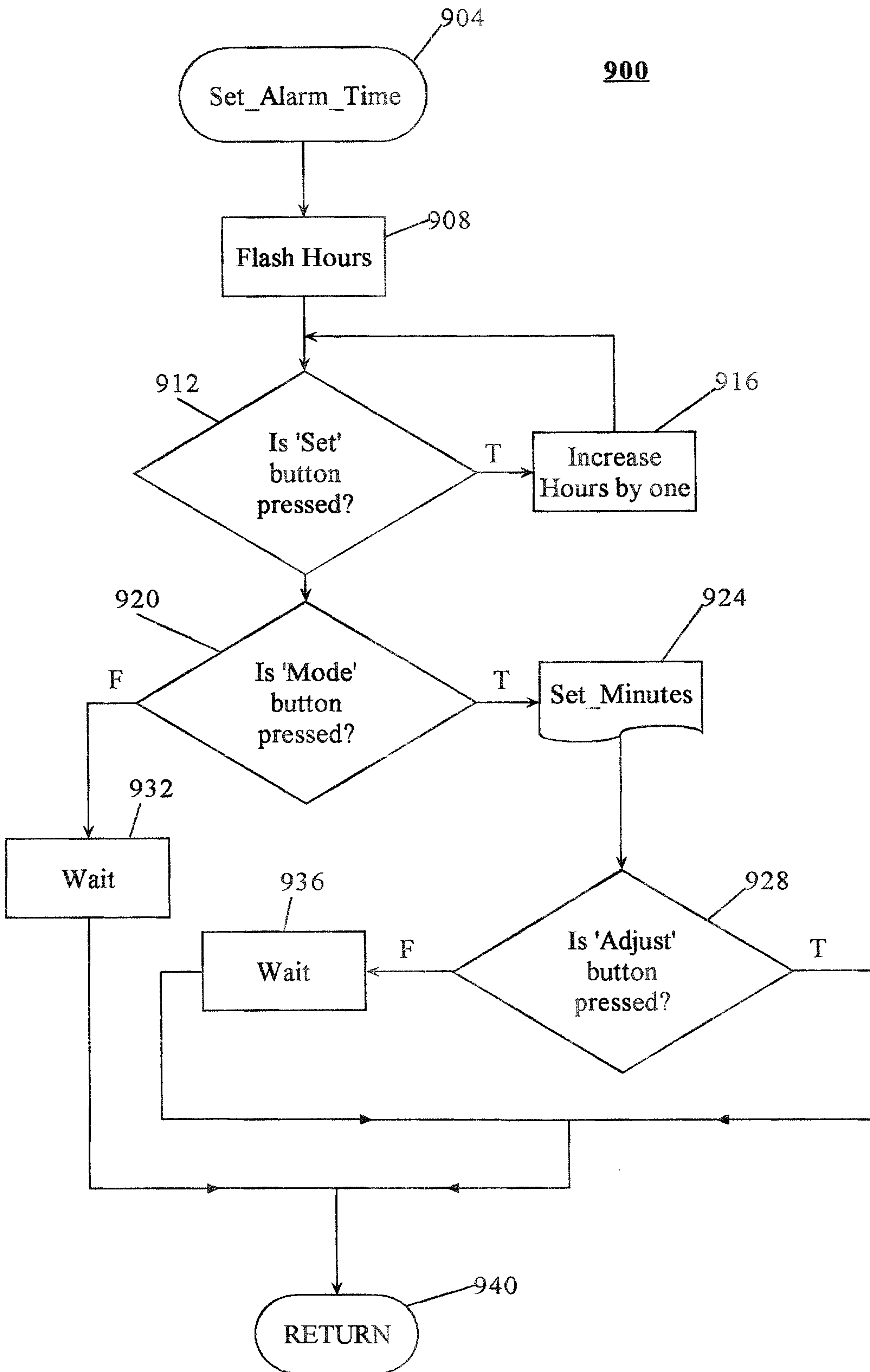

FIG. 10 Activating Alarm

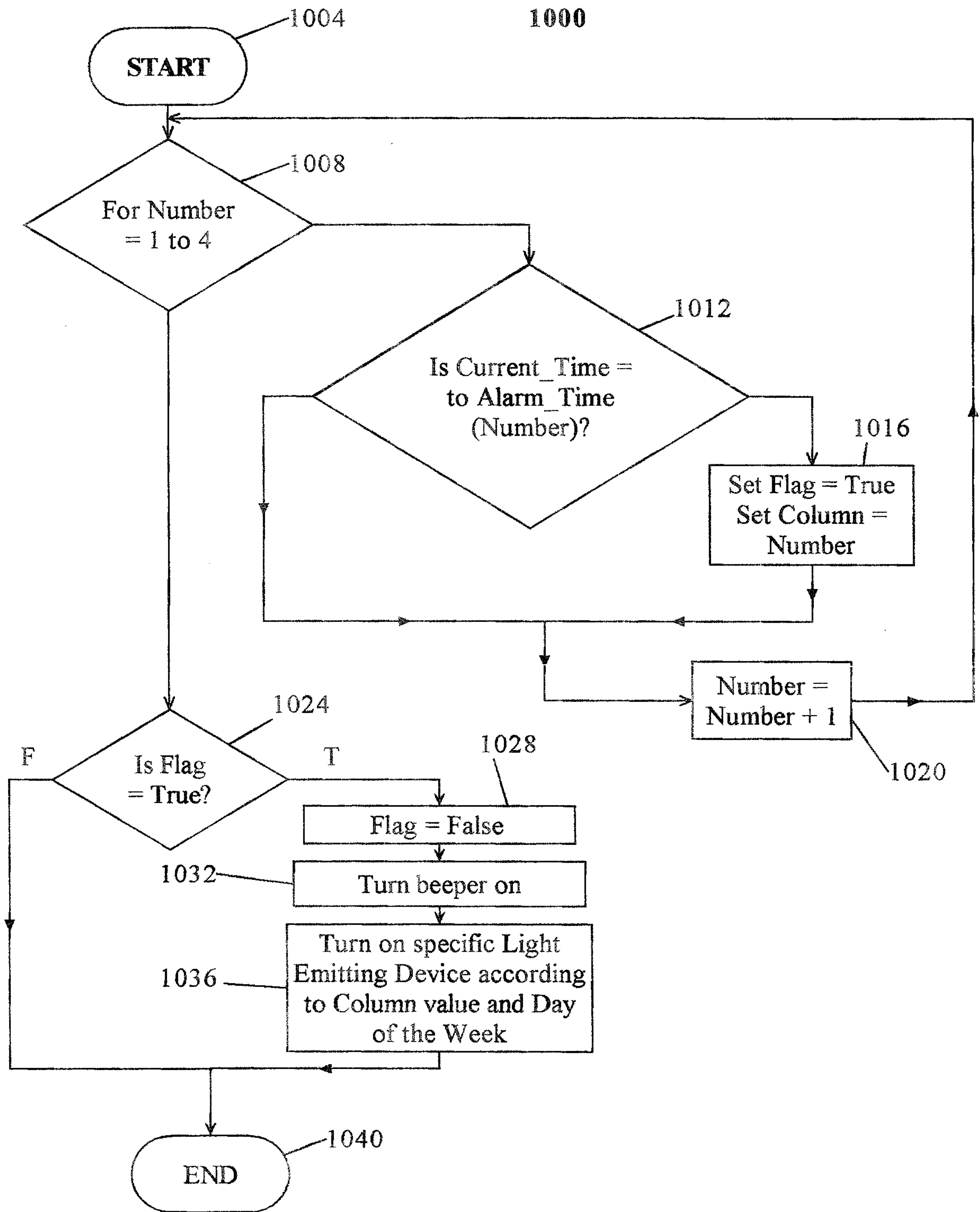

FIG. 11 Resetting Active Alarm

