



(51) International Patent Classification:

A44B 19/32 (2006.01) A44B 19/36 (2006.01)

(21) International Application Number:

PCT/CA2017/050477

(22) International Filing Date:

18 April 2017 (18.04.2017)

(25) Filing Language:

English

(26) Publication Language:

English

(30) Priority Data:

62/334,732 11 May 2016 (11.05.2016) US

(71) Applicant: OCEAN RODEO SPORTS INC. [CA/CA];
41 Cadillac Avenue, Victoria, British Columbia V8Z 1T3
(CA).

(72) Inventors: MYERSCOUGH, Richard Kerr; 41 Cadillac
Avenue, Victoria, British Columbia V8Z 1T3 (CA). HAR-
RINGTON, Ross Davis; 41 Cadillac Avenue, Victoria,
British Columbia V8Z 1T3 (CA).

(74) Agent: THOMPSON, Douglas B. et al.; Thompson Coop-
er LLP, Suite 201, 1007 Fort Street, Victoria, British Co-
lumbia V8V 3K5 (CA).

(81) Designated States (unless otherwise indicated, for every
kind of national protection available): AE, AG, AL, AM,
AO, AT, AU, AZ, BA, BB, BG, BH, BN, BR, BW, BY, BZ,
CA, CH, CL, CN, CO, CR, CU, CZ, DE, DJ, DK, DM, DO,
DZ, EC, EE, EG, ES, FI, GB, GD, GE, GH, GM, GT, HN,
HR, HU, ID, IL, IN, IR, IS, JP, KE, KG, KH, KN, KP, KR,
KW, KZ, LA, LC, LK, LR, LS, LU, LY, MA, MD, ME, MG,
MK, MN, MW, MX, MY, MZ, NA, NG, NI, NO, NZ, OM,
PA, PE, PG, PH, PL, PT, QA, RO, RS, RU, RW, SA, SC,
SD, SE, SG, SK, SL, SM, ST, SV, SY, TH, TJ, TM, TN, TR,
TT, TZ, UA, UG, US, UZ, VC, VN, ZA, ZM, ZW.

(84) Designated States (unless otherwise indicated, for every
kind of regional protection available): ARIPO (BW, GH,
GM, KE, LR, LS, MW, MZ, NA, RW, SD, SL, ST, SZ, TZ,
UG, ZM, ZW), Eurasian (AM, AZ, BY, KG, KZ, RU, TJ,
TM), European (AL, AT, BE, BG, CH, CY, CZ, DE, DK,
EE, ES, FI, FR, GB, GR, HR, HU, IE, IS, IT, LT, LU, LV,
MC, MK, MT, NL, NO, PL, PT, RO, RS, SE, SI, SK, SM,
TR), OAPI (BF, BJ, CF, CG, CI, CM, GA, GN, GQ, GW,
KM, ML, MR, NE, SN, TD, TG).

Published:

- with international search report (Art. 21(3))
- with amended claims and statement (Art. 19(1))

(54) Title: METHOD OF SEALING A ZIPPER CLOSURE AND A SEALED ZIPPER ASSEMBLY

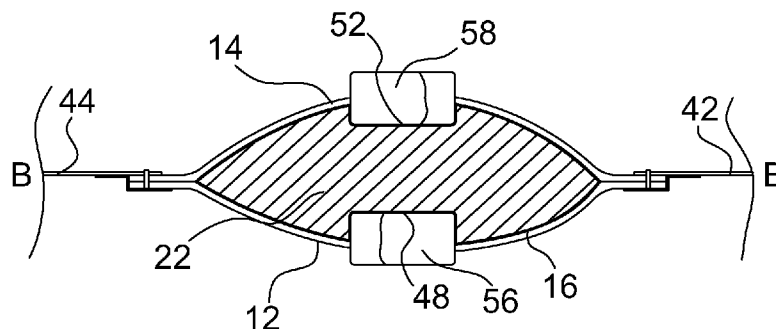

FIG. 9

(57) Abstract: A sealed zipper assembly includes a first zipper segment and a second zipper segment in overlapping relation to create a sealing zone. A sealing element is positioned in the sealing zone to prevent leakage between the first zipper segment and the second zipper segment.



TITLE

[0001] Method of sealing a zipper closure and a sealed zipper assembly

FIELD

5 [0002] There is described a method of sealing a zipper closure and a sealed zipper assembly that can be used in applications involving liquids or potentially harmful gases.

BACKGROUND

[0003] EP Patent specification 1,481,601 (Kallionpaa) titled "Closure for zipper ends",
10 discloses a sealing mechanism for a zipper closure. However, the sealing mechanism taught by the Kallionpaa reference is not ideal. The sealing mechanism is complicated to use and the material around the sealing mechanism tends to become fatigued, eventually leading to failure. The bulk of the sealing mechanism is uncomfortable to wear in some applications. There is, therefore, a need for an alternative method of sealing a zipper closure and an
15 alternative sealed zipper assembly.

SUMMARY

[0004] According to one aspect there is provided a method of sealing a zipper closure. A step is taken of providing a first zipper segment and a second zipper segment in overlapping
20 relation to create at least one sealing zone. A further step is taken of positioning a sealing element in the at least one sealing zone to prevent leakage between the first zipper segment and the second zipper segment.

[0005] According to another aspect there is provided a sealed zipper assembly which
25 includes a first zipper segment and a second zipper segment in overlapping relation to create at least one sealing zone. A sealing element is positioned in the at least one sealing zone to prevent leakage between the first zipper segment and the second zipper segment.

[0006] It will be appreciated that the sealing element used may vary. There will
30 hereinafter be described with reference to the drawings various alternative sealing elements. One sealing element is a resiliently deformable sealing element that is compressed within the sealing zone. Another sealing element is an expandable sealing element that expands to occupy the sealing zone. Yet another sealing element is a plug that is wedged into the at least

one sealing zone. Yet another sealing element is plug that can be compressed lengthwise via an internal screw tensioner.

[0007] It will also be appreciated, that the assembly may involve differing numbers of interlocking zipper fasteners. There will hereinafter be described a first embodiment in which there is a single interlocking zipper fastener and a single sealing zone. The single interlocking zipper fastener has a first series of interlocking teeth and a second series of interlocking teeth and a least one slider. The single interlocking zipper fastener has a first end that serves as the first zipper segment and a second end that serves as the second zipper segment. There will hereinafter be described another embodiment in which there is more than one interlocking zipper fastener and more than one sealing zone. Each interlocking zipper fastener has a first end and a second end. The first end of one interlocking zipper fastener serves as the first zipper segment and the second end of another interlocking zipper fastener serves as the second zipper segment.

[0008] It will also be appreciated that when the first zipper segment and the second zipper segment are overlapping, they are not necessarily parallel to the one or more interlocking zipper fasteners. There will hereinafter be described an embodiment in which the first zipper segment and the second zipper segment, which form the at least one sealing zone, project outwardly from the one or more interlocking zipper fasteners. In a circular configuration, this might be described as projecting radially.

[0009] The method of sealing a zipper closure and the sealed zipper assembly will hereinafter be described with respect to embodiment in which one or more interlocking zipper fastener are arranged in a substantially circular configuration. This configuration is the one that was developed for the applicant's intended application. It will be appreciated that the teachings are equally applicable to linear applications.

BRIEF DESCRIPTION OF THE DRAWINGS

[0010] These and other features will become more apparent from the following description in which reference is made to the appended drawings, the drawings are for the purpose of illustration only and are not intended to be in any way limiting, wherein:

- [0011] FIG. 1 is a front elevation view of a first embodiment of sealed zipper assembly in a closed position.
- [0012] FIG. 2 is a front elevation view of the first embodiment of sealed zipper assembly illustrated in FIG. 1, in an open position.
- 5 [0013] FIG. 3 is a front elevation view of the first embodiment of sealed zipper assembly illustrated in FIG. 1, in a slider starting position.
- [0014] FIG. 4 is a front elevation view of the first embodiment of sealed zipper assembly illustrated in FIG. 1, in a slider closing position.
- [0015] FIG. 5 is a rear elevation view of the first embodiment of sealed zipper assembly
10 illustrated in FIG. 1, in a closed position.
- [0016] FIG. 6 is a section view of the first embodiment of sealed zipper assembly taken along section lines A-A of FIG. 1.
- [0017] FIG. 7 is a top plan view of the first embodiment of sealed zipper assembly illustrated in FIG. 1.
- 15 [0018] FIG. 8 is a front elevation view of the first embodiment of sealed zipper assembly illustrated in FIG. 1, in an open position with a sealing element.
- [0019] FIG. 9 is a section view of the first embodiment of sealed zipper assembly taken along section lines B-B of FIG. 8.
- [0020] FIG. 10 is a top plan view of the first embodiment of sealed zipper assembly
20 illustrated in FIG. 8.
- [0021] FIG. 11 is a perspective view of a sealing element illustrated in FIG. 9
- [0022] FIG. 12 is a front elevation view of a second embodiment of sealed zipper assembly in an open position.
- [0023] FIG. 13 is a section view of the second embodiment of sealed zipper assembly
25 taken along section lines C-C of FIG. 12.
- [0024] FIG. 14 is a top plan view of the second embodiment of sealed zipper assembly illustrated in FIG. 12.
- [0025] FIG. 15 is an exploded perspective view of a sealing element illustrated in FIG. 13.
- [0026] FIG. 16 is a section view of a third embodiment of sealed zipper assembly.
- 30 [0027] FIG. 17 is a perspective view of a sealing element illustrated in FIG. 16.
- [0028] FIG. 18 is a front elevation view of a fourth embodiment of sealed zipper assembly

in a closed position, prior to sealing.

[0029] FIG. 19 is a front elevation view of the fourth embodiment of sealed zipper assembly illustrated in FIG. 18, with sealing element inserted into the sealing zone.

[0030] FIG. 20 is a section view of a fifth embodiment of sealed zipper assembly.

5 [0031] FIG. 21 is a section view of a sixth embodiment of sealed zipper assembly.

[0032] FIG. 22 is a top plan view of a seventh embodiment of sealed zipper assembly.

[0033] FIG. 23 is a top plan view of an eighth embodiment of sealed zipper assembly.

[0034] FIG. 24 is a perspective view of an alternative sealing element having an air transfer tube.

10 [0035] FIG. 25 is a perspective view of an inflatable sealing element.

[0036] FIG. 26 is a front elevation view of an alternative sealing element that is compressible in a lengthwise direction.

DETAILED DESCRIPTION

15 [0037] A first embodiment of sealed zipper assembly will now be described with reference to FIG. 1 through FIG. 11. Embodiment variations will be described with reference to FIG. 12 through FIG. 26.

20 Structure and Relationship of Parts:

[0038] Referring to FIG. 10, first embodiment 10 of sealed zipper assembly includes a first zipper segment 12 and a second zipper segment 14 in overlapping relation to create a sealing zone 16. Referring to FIG. 6 and FIG. 9, sealing zone 16 can be viewed as forming a tunnel. Referring to FIG. 10, in this regard, sealing zone 16 has an exterior opening 18 and an interior opening 20. Referring to FIG. 9 and FIG. 10, a sealing element 22 is positioned in sealing zone 16 to prevent leakage between first zipper segment 12 and second zipper segment 14. Referring to FIG. 11, sealing element 22 is illustrated. Referring to FIG. 9 and FIG. 10, sealing element 22 is resiliently deformable and is compressed within sealing zone 16 by first zipper segment 12 and second zipper segment 14. Referring to FIG. 10, it will be
25
30 noted that with first embodiment 10 first zipper segment 12 and second zipper segment 14 are part of a single interlocking zipper fastener 24 and create a single sealing zone, previously identified as sealing zone 16. As will hereinafter be illustrated and described with reference

to embodiment variations there can be more than one interlocking zipper fastener and more than one sealing zone.

[0039] Referring to FIG. 1 through FIG. 5 and FIG. 8, interlocking zipper fastener 24
5 having a first series of interlocking teeth 26 supported on a band 28 and a second series of interlocking teeth 30 supported on a band 32. At least one slider 34 is provided. Referring to FIG. 7 and FIG. 10, interlocking zipper fastener 24 has a first end 36 that serves as first zipper segment 12 and a second end 38 that serves as second zipper segment 14 in this embodiment.

10 [0040] Referring to FIG. 2, a garment body 40 made with waterproof fabric consists of a first or upper discrete body component 42 and a second or lower discrete body component 44. Interlocking zipper fastener 24 is in a circular configuration that enables first discrete body component 42 to be separated from second discrete body component 44. Referring to FIG. 2, band 28 supporting first series of interlocking teeth 26 constituting a first half of interlocking
15 zipper fastener 24 is secured to first discrete body component 42 in a generally circular configuration to form a first half of first zipper segment 12 and a first half of second zipper segment 14 in overlapping relation. Similarly, band 32 supporting second series of interlocking teeth 30 constituting a second half of interlocking zipper fastener 24 is secured to second discrete body 44 component in a generally circular configuration to form a second half
20 of the first zipper segment 12 and a second half of the second zipper segment 14 in overlapping relation.

[0041] Referring to FIG. 3, slider 34 is used to slides along interlocking zipper fastener 24 in a first direction to bring first series of interlocking teeth 26 and second series of
25 interlocking teeth 30 into engagement as illustrated in FIG. 1. Referring to FIG. 4, slider 34 slides along interlocking zipper fastener 24 in a second direction to disengage first series of interlocking teeth 26 and second series of interlocking teeth 30 to disengage interlocking zipper fastener 24, as illustrated in FIG. 2. Referring to FIG. 6, FIG. 7, FIG. 9 and FIG. 10, as slider 34 interlocks first series of interlocking teeth 26 and second series of interlocking teeth
30 30, it completes first zipper segment 12 and second zipper segment 14, the overlapping of which creates sealing zone 16. Sealing zone 16 is then ready to receive sealing element 22. Referring to FIG. 8, sealing element 22 has ridges 46 that assist in sealing. Sealing element

22 also has a first channel 48 on a first face 50 and a second channel 52 on a second face 54. Referring to FIG. 9, First channel 48 receives interlocked teeth 56 of first zipper segment 12 and second channel 52 receives interlocked teeth 58 of second zipper segment 14.

5 Operation:

[0042] Referring to FIG. 2, band 28 supporting first series of interlocking teeth 26 constituting a first half of interlocking zipper fastener 24 is secured to first discrete body component 42 in a generally circular configuration to form a first half of first zipper segment 12 and a first half of second zipper segment 14 in overlapping relation. Band 32 supporting
10 second series of interlocking teeth 30 constituting a second half of interlocking zipper fastener 24 is secured to second discrete body 44 component in a generally circular configuration to form a second half of the first zipper segment 12 and a second half of the second zipper segment 14 in overlapping relation. Referring to FIG. 3, slider 34 slides along interlocking zipper fastener 24 in a first direction to bring first series of interlocking teeth 26 and second
15 series of interlocking teeth 30 into engagement as illustrated in FIG. 1. Referring to FIG. 6 and FIG. 7, as slider 34 interlocks first series of interlocking teeth 26 and second series of interlocking teeth 30, it completes first zipper segment 12 and second zipper segment 14 the overlapping of which creates sealing zone 16. FIG. 9 and FIG. 10, sealing element 22 is compressed within sealing zone 16 by first zipper segment 12 and second zipper segment 14.

20

Variations:

[0043] There will hereinafter be described variations that may be made to the first embodiment. With each variation, elements that are identical to the first embodiment will be
25 identified by identical reference numerals. Only those aspects that differ from the first embodiment will be described.

[0044] The first embodiment illustrated a single sealing element 22. Referring to FIG. 15, there is illustrated an alternative sealing element 122 that has a first seal component 124 and a
30 second seal component 126. Referring to FIG. 12, first seal component 124 is wedged into and held by friction or otherwise secured to first discrete body component 42. Second seal

component 126 is wedged into and held by friction or otherwise secured to second discrete body component 44. Referring to FIG. 13 and FIG. 14, when interlocking zipper fastener 24 is closed, first seal component 124 and second seal component 126 are forced together to form sealing element 122 which fills sealing zone 16.

5

[0045] In the first embodiment, sealing element 22 was held in place by friction and was removable. Referring to FIG. 16 and FIG. 17, alternative sealing element 222 has a fabric strip 224 moulded into the elastomeric foam. Fabric strip 224 is used to secure alternative sealing element 222 to first discrete body component 42. This is done by stitching through fabric strip 224. Fabric strip 224 serves to anchor alternative sealing element 222 to first discrete body component 42 in a desired position where sealing zone 16 is formed by the overlapping of first zipper segment 12 and second zipper segment 14 of interlocking zipper fastener 24. It will be appreciated that there are other ways to secure alternative sealing element within sealing zone 16.

10

15

[0046] In the first embodiment, sealing element 22 was elastomeric foam. Referring to FIG. 18 and FIG. 19 an alternative sealing element 322 is illustrated. Referring to FIG. 18, sealing element 322 is a plug 324 that is suspended by a tether 326 from slider 34 when not in use. Referring to FIG. 19, plug 324 is intended to be inserted into exterior opening 18 of sealing zone 16 to seal sealing zone 16. It is preferred that plug 324 have a surface profile, such as ribs or ridges, to enhance both the sealing capacity and the holding capacity of plug 324. It will be appreciated that there are other raised surface profiles that would similarly serve this purpose.

20

25

[0047] In the first embodiment, first zipper segment 12 and second zipper segment 14 are positioned substantially parallel to interlocking zipper fastener 24. Referring to FIG. 22, first zipper segment 12 and second zipper segment 14 which form sealing zone 16, can be configured so that they project outwardly or radially from interlocking zipper fastener 24.

30

[0048] In the first embodiment, there was only one interlocking zipper fastener 24 and only one sealing zone 16. Referring to FIG. 23, there is shown a configuration that has more than one interlocking zipper fastener 24 and more than one sealing zone 16. With this

configuration, first end 36 of one interlocking zipper fastener 24 serves as first zipper segment 12 and second end 38 of another interlocking zipper fastener 124 serves as second zipper segment 14 to create a first sealing zone 16. In addition, first end 36 of interlocking zipper fastener 124 serves as first zipper segment 12 and second end 38 of interlocking zipper fastener 24 serves as second zipper segment 14 to create a second sealing zone 116. It will be appreciated that although two interlocking zipper fasteners 24 and 124 have been illustrated in a circular configuration more than two interlocking zipper fastener could also be arranged in a circular configuration in a like manner.

10 [0049] It is not unusual for a garment intended for use in water, such as garment body 40 to have air transfer valves, to provide for air movement. Referring to FIG. 24, alternative sealing element 422 is shown with an air transfer tube 424 extending through the body of alternative sealing element 422. Air transfer tube 424 allows for movement of air in and out of garment body 40. When garment body 40 is to be submerged in water or another liquid, a closure valve 426 can be used to close air transfer tube 424.

[0050] In the first embodiment, sealing element 22 was compressed. Referring to FIG. 25, a bladder like alternative sealing element 522 is shown which is expandable like a balloon. Alternative sealing element 522 has a tube 524 into which a user may blow to inflate alternative sealing element 522 and a closure valve 526 that is to maintain air pressure within alternative sealing element 522. When expanded, alternative sealing element 522 expands to occupy sealing zone 16.

25 [0051] Another alternative sealing element is positioned between two clamping elements with at least one of the clamping elements being movable toward and away from another of the clamping elements. As the clamping elements are moving closer together, the sealing element is forced outwardly to seal the sealing zone. Referring to FIG. 26, one such clamping configuration is illustrated. Alternative sealing element 622 has a bolt 624 that runs through its lengthwise. There is a nut 626 on one end of the bolt 624 and a twist knob 628 on the other end of bolt 624. Nut 626 serves as one clamping element and twist knob 626 serves as another clamping element. Turning twist knob 628 causes axial movement that compresses

alternative sealing element 622 between twist knob 628 and nut 626. When compressed, alternative sealing element 622 expands outwardly increasing the circumference of alternative sealing element 622 until alternative sealing element 622 seals the sealing zone.

5 Advantages:

[0052] The method of sealing a zipper closure and the sealed zipper assemblies described above provide a number of advantages:

[0053] 1. It is relatively simple to use, when compared with the Kallionpaa reference.

[0054] 2. It is less expensive to manufacture, when compared with the Kallionpaa
10 reference.

[0055] 3. It has less bulk and is more comfortable to wear, when compared with the Kallionpaa reference.

[0056] 4. It has greater flex and is less subject to material fatigue, when compared with the Kallionpaa reference.

15 [0057] 5. It will work with any most, if not all, brands and styles of dry zipper.

[0058] 6. It has a degree of adjustability to fit difference circumferences by increasing or decreasing the amount of overlap, whereas the Kallionpaa reference is an endless loop that must be made to a specific circumference.

[0059] 7. If air transfer is desired, an air transfer tube can be positioned through the
20 sealing element to avoid making extra holes in garment 40 to accommodate air transfer valves.

Cautionary Warnings:

[0060] It will be appreciated that not all zippers can function in a liquid environment. In
25 order to avoid leakage, one has to use a waterproof zipper. It will also be appreciated that there are a number of different styles of waterproof zippers. Suitable waterproof zippers will be known to persons familiar with underwater diving and will, therefore, not be listed here.

[0061] In order for the sealing elements described above to be effective, there are a
30 number of leakage points along stitches and seams that must be effectively sealed.

[0062] Referring to FIG. 1, stitches 50 are used to secure interlocking zipper fastener 24 in place. Referring to FIG. 5, waterproof tape 52 is heat sealed or secured by adhesive to reverse side of stitches 50 to prevent liquids weeping through stitches 50.

5 [0063] Referring to FIG. 20 and FIG. 21, sealing zone 16 has edge seams 54 that are subject to leakage. Referring to FIG. 20, leakage can be addressed by sealing edge seams 54 with pliable edge moulding 56. Referring to FIG. 21, leakage can also be addressed by sealing edge seams 54 by using a bead 58 of polymer caulking compound,

10 [0064] In this patent document, the word "comprising" is used in its non-limiting sense to mean that items following the word are included, but items not specifically mentioned are not excluded. A reference to an element by the indefinite article "a" does not exclude the possibility that more than one of the element is present, unless the context clearly requires that there be one and only one of the elements.

15

[0065] The illustrated embodiments have been set forth only as examples and should not be taken as limiting a purposive interpretation of the claims.

What is Claimed is:

- 5 1. A method of sealing a zipper closure, comprising:
 providing at least one first zipper segment and at least one second zipper
 segment in overlapping relation to create at least one sealing zone; and
 positioning a sealing element in the at least one sealing zone to prevent
 leakage between the first zipper segment and the second zipper segment.
- 10 2. The method of Claim 1, wherein the sealing element is a resiliently deformable
 sealing element that is compressed within the at least one sealing zone.
3. The method of Claim 1, wherein the sealing element is an expandable sealing element
15 that expands to occupy the at least one sealing zone.
4. The method of Claim 1, wherein the sealing element is a plug that is wedged into the
 at least one sealing zone.
- 20 5. The method of Claim 4, wherein the plug is secured by a tether to an interlocking
 zipper fastener and is manually movable between an operative sealing position in the
 at least one sealing zone and a stored position withdrawn from the at least one sealing
 zone.
- 25 6. The method of Claim 1, wherein an air transfer tube extends through the sealing
 element, the air transfer tube having a closure valve.
7. The method of Claim 1, wherein the sealing element is attached to an interlocking
 zipper fastener where the first zipper segment and the second zipper segment overlap
30 to form the sealing zone.
8. The method of Claim 1, wherein there is a single interlocking zipper fastener and a

single sealing zone, the single interlocking zipper fastener having a first series of interlocking teeth and a second series of interlocking teeth and a least one slider, the single interlocking zipper fastener having a first end that serves as the first zipper segment and a second end that serves as the second zipper segment.

5

9. The method of Claim 1, wherein there is one or more interlocking zipper fasteners and the first zipper segment and the second zipper segment which form the at least one sealing zone project outwardly from the one or more interlocking zipper fasteners.

10

10. The method of Claim 1, wherein there is more than one interlocking zipper fastener, each interlocking zipper fastener having a first series of interlocking teeth and a second series of interlocking teeth and a least one slider, each interlocking zipper fastener having a first end and a second end, the first end of one interlocking zipper fastener serving as the first zipper segment and the second end of another interlocking zipper fastener serving as the second zipper segment.

15

11. The method of Claim 10, wherein the more than one interlocking zipper fastener is arranged in a circular configuration.

20

12. The method of Claim 1, wherein the sealing element is positioned between two clamping elements with at least one of the clamping elements being movable toward and away from another of the clamping elements, such that the clamping elements are moving closer together forces the sealing element outwardly to seals the sealing zone.

25

13. The method of Claim 1, wherein comprising:

providing a body comprised of a first discrete body component and a second discrete body component;

30

providing one or more interlocking zipper fasteners, each of the one or more interlocking zipper fastener having a first series of interlocking teeth and a second series of interlocking teeth and a least one slider that slides long each interlocking zipper fastener in a first direction to bring the first series of interlocking teeth and the

second series of interlocking teeth into engagement and slides along each interlocking zipper fastener in a second direction to disengage the first series of interlocking teeth and the second series of interlocking teeth, each interlocking zipper fastener having a discrete first end and a discrete second end;

5 securing the first series of interlocking teeth comprising a first half of the one or more interlocking zipper fasteners to the first discrete body component in a generally circular configuration with the first half of the one or more interlocking zipper fasteners providing a first half of the first zipper segment and a first half of the second zipper segment in overlapping relation;

10 securing the second series of interlocking teeth comprising a second half of the one or more interlocking zipper fasteners to the second discrete body component in a generally circular configuration with the second half of the one or more interlocking zipper fasteners providing a second half of the first zipper segment and a second half of the second zipper segment in overlapping relation;

15 sliding the slider on each of the one or more interlocking zipper fasteners interlock the first series of interlocking teeth and the second series of interlocking teeth, thereby completing the first zipper segment and the second zipper segment the overlapping of which create the at least one sealing zone; and

20 positioning the at least one sealing element in the at least one sealing zone to prevent leakage between the first zipper segment and the second zipper segment.

14. A sealed zipper assembly, comprising:

 a first zipper segment and a second zipper segment in overlapping relation to create at least one sealing zone; and

25 a sealing element in the at least one sealing zone to prevent leakage between the first zipper segment and the second zipper segment.

15. The sealed zipper assembly of Claim 14, wherein the sealing element is a resiliently deformable sealing element that is compressed within the at least one sealing zone.

30

16. The sealed zipper assembly of Claim 14, wherein the sealing element is an

expandable sealing element that expands to occupy the at least one sealing zone.

17. The sealed zipper assembly of Claim 14, wherein the sealing element is a plug that is wedged into the at least one sealing zone.
- 5
18. The sealed zipper assembly of Claim 17, wherein the plug is secured by a tether to an interlocking zipper fastener and is manually movable between an operative sealing position in the at least one sealing zone and a stored position withdrawn from the at least one sealing zone.
- 10
19. The sealed zipper assembly of Claim 14, wherein an air transfer tube extends through the sealing element, the air transfer tube having a closure valve.
20. The sealed zipper assembly of Claim 14, wherein the sealing element is attached to an interlocking zipper fastener where the first zipper segment and the second zipper segment overlap to form the sealing zone.
- 15
21. The sealed zipper assembly of Claim 14, wherein there is a single interlocking zipper fastener and a single sealing zone, the single interlocking zipper fastener having a first series of interlocking teeth and a second series of interlocking teeth and a least one slider, the single interlocking zipper fastener having a first end that serves as the first zipper segment and a second end that serves as the second zipper segment.
- 20
22. The sealed zipper assembly of Claim 14, wherein there is one or more interlocking zipper fasteners with the first zipper segment and the second zipper segment which form the at least one sealing zone projecting outwardly from the one or more interlocking zipper fasteners.
- 25
23. The sealed zipper assembly of Claim 14, wherein there is more than one interlocking zipper fastener and more than one sealing zone, each interlocking zipper fastener having a first series of interlocking teeth and a second series of interlocking teeth and a least one slider, each interlocking zipper fastener having a first end and a second end, the first end of one interlocking zipper fastener serving as the first zipper segment
- 30

and the second end of another interlocking zipper fastener serving as the second zipper segment.

24. The sealed zipper assembly of Claim 23, wherein the more than one interlocking zipper fastener are arranged in a circular configuration.
25. The sealed zipper assembly of Claim 14, wherein the sealing element is positioned between two clamping elements with at least one of the clamping elements being movable toward and away from another of the clamping elements, such that the clamping elements are moving closer together forces the sealing element outwardly to seals the sealing zone.
26. The sealed zipper assembly of Claim 14, wherein comprising:
- a body comprised of a first discrete body component and a second discrete body component;
 - one or more interlocking zipper fasteners, each of the one or more interlocking zipper fastener having a first series of interlocking teeth and a second series of interlocking teeth and a least one slider that slides long each interlocking zipper fastener in a first direction to bring the first series of interlocking teeth and the second series of interlocking teeth into engagement and slides along each interlocking zipper fastener in a second direction to disengage the first series of interlocking teeth and the second series of interlocking teeth, each interlocking zipper fastener having a discrete first end and a discrete second end;
 - the first series of interlocking teeth comprising a first half of the one or more interlocking zipper fasteners being secured to the first discrete body component in a generally circular configuration with the first half of the one or more interlocking zipper fasteners providing a first half of the first zipper segment and a first half of the second zipper segment in overlapping relation;
 - the second series of interlocking teeth comprising a second half of the one or more interlocking zipper fasteners being secured the second discrete body component in a generally circular configuration with the second half of the one or more interlocking zipper fasteners providing a second half of the first zipper segment and a

second half of the second zipper segment in overlapping relation;

the slider on each of the one or more interlocking zipper fasteners serving to interlock the first series of interlocking teeth and the second series of interlocking teeth, thereby completing the first zipper segment and the second zipper segment the overlapping of which creates the at least one sealing zone; and

5

the at least one sealing element being positioned in the at least one sealing zone to prevent leakage between the first zipper segment and the second zipper segment.

AMENDED CLAIMS

received by the International Bureau on 16 August 2017 (16.08.2017)

1. A method of sealing a zipper closure, comprising:

providing a single waterproof interlocking zipper fastener having a first series of interlocking teeth, a second series of interlocking teeth and a slide that slides in a first direction to bring the first series of interlocking teeth and the second series of interlocking teeth into engagement and slides in a second direction to disengage the first series of interlocking teeth and the second series of interlocking teeth, the single waterproof interlocking zipper fastener having a first end that serves as a first zipper segment and a second end that serves as a second zipper segment, the first zipper segment and the second zipper segment being in overlapping relation to create an area of overlap with at least one sealing zone; and

positioning a sealing element in the at least one sealing zone to prevent leakage between the first zipper segment and the second zipper segment axially along the area of overlap.

2. The method of Claim 1, wherein the sealing element is a resiliently deformable sealing element that is compressed within the at least one sealing zone.
3. The method of Claim 1, wherein the sealing element is an expandable sealing element that expands to occupy the at least one sealing zone.
4. The method of Claim 1, wherein the sealing element is a plug that is wedged into the at least one sealing zone.
5. The method of Claim 4, wherein the plug is secured by a tether to an interlocking zipper fastener and is manually movable between an operative sealing position in the at least one sealing zone and a stored position withdrawn from the at least one sealing zone.
6. The method of Claim 1, wherein an air transfer tube extends through the sealing element, the air transfer tube having a closure valve.
7. The method of Claim 1, wherein the sealing element is attached to an interlocking zipper fastener where the first zipper segment and the second zipper segment overlap to form the sealing zone.

8. The method of Claim 1, wherein the sealing element is positioned between two clamping elements with at least one of the clamping elements being movable toward and away from another of the clamping elements, such that the clamping elements are moving closer together forces the sealing element outwardly to seals the sealing zone.
9. The method of Claim 1, comprising:
- providing a body comprised of a first discrete body component and a second discrete body component;
 - securing the first series of interlocking teeth to the first discrete body component in a generally circular configuration;
 - securing the second series of interlocking teeth to the second discrete body component in a generally circular configuration.
10. A sealed zipper assembly, comprising:
- a single waterproof interlocking zipper fastener having a first series of interlocking teeth, a second series of interlocking teeth and a slide that slides in a first direction to bring the first series of interlocking teeth and the second series of interlocking teeth into engagement and slides in a second direction to disengage the first series of interlocking teeth and the second series of interlocking teeth, the single waterproof interlocking zipper fastener having a first end that serves as a first zipper segment and a second end that serves as a second zipper segment, the first zipper segment and the second zipper segment being in overlapping relation to create an area of overlap with at least one sealing zone; and
 - a sealing element positioned in the at least one sealing zone to prevent leakage between the first zipper segment and the second zipper segment axially along the area of overlap.
11. The sealed zipper assembly of Claim 10, wherein the sealing element is a resiliently deformable sealing element that is compressed within the at least one sealing zone.
12. The sealed zipper assembly of Claim 10, wherein the sealing element is an expandable sealing element that expands to occupy the at least one sealing zone.
13. The sealed zipper assembly of Claim 10, wherein the sealing element is a plug that is wedged into the at least one sealing zone.

14. The sealed zipper assembly of Claim 13, wherein the plug is secured by a tether to an interlocking zipper fastener and is manually movable between an operative sealing position in the at least one sealing zone and a stored position withdrawn from the at least one sealing zone.
15. The sealed zipper assembly of Claim 10, wherein an air transfer tube extends through the sealing element, the air transfer tube having a closure valve.
16. The sealed zipper assembly of Claim 10, wherein the sealing element is attached to an interlocking zipper fastener where the first zipper segment and the second zipper segment overlap to form the sealing zone.
17. The sealed zipper assembly of Claim 10, wherein the sealing element is positioned between two clamping elements with at least one of the clamping elements being movable toward and away from another of the clamping elements, such that the clamping elements are moving closer together forces the sealing element outwardly to seals the sealing zone.
18. The sealed zipper assembly of Claim 10, comprising:
- a body comprised of a first discrete body component and a second discrete body component;
 - the first series of interlocking teeth secured to the first discrete body component in a generally circular configuration;
 - the second series of interlocking teeth secured to the second discrete body component in a generally circular configuration.

STATEMENT UNDER ARTICLE 19

Responsive to the International Search Report, Claim 1 has been amended to insert subject matter from claim 8, acknowledged by the International Search Report to be patentable, into method Claim 1. A similar amendment has been made to insert subject matter from claim 21, acknowledged by the International Search Report to be patentable, into product Claim 10 (formerly claim 14). Both claims now recite a “single waterproof interlocking zipper fastener having a first end that serves as a first zipper segment and a second end that serves as a second zipper segment, the first zipper segment and the second zipper segment being in overlapping relation to create an area of overlap with at least one sealing zone”.

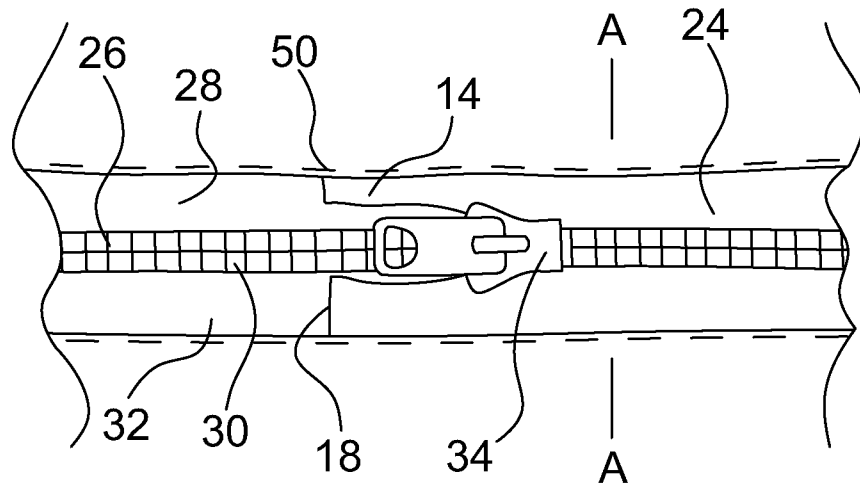

FIG. 1

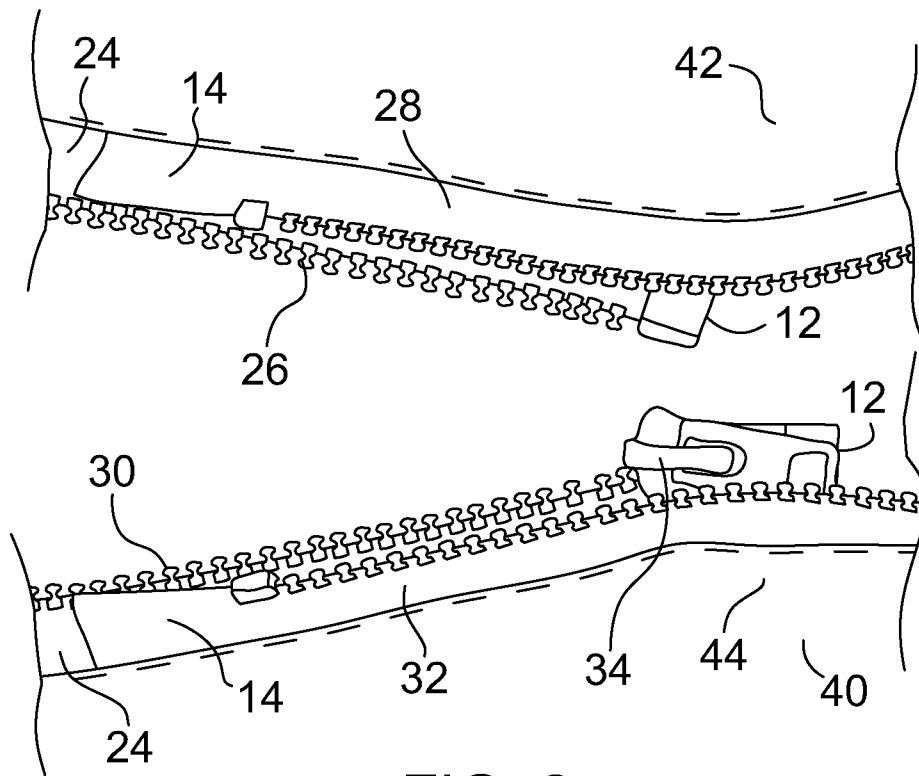

FIG. 2

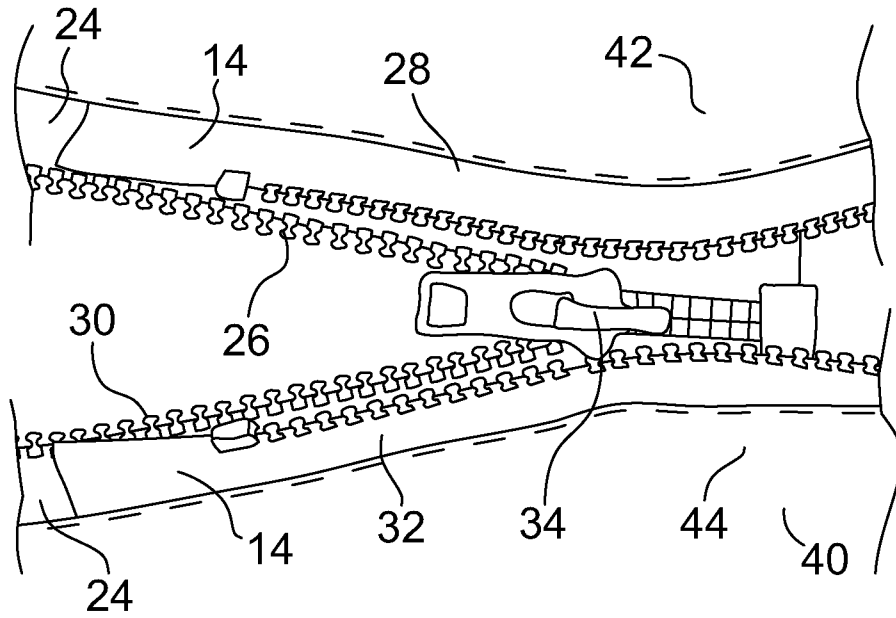

FIG. 3

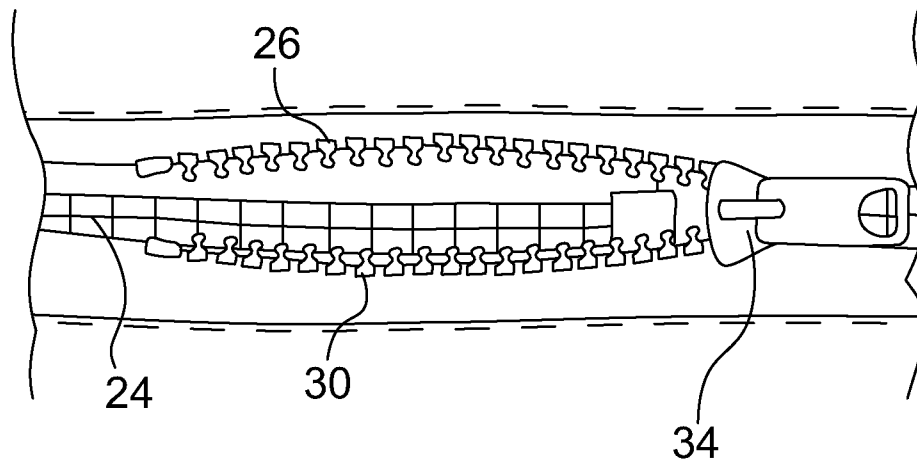

FIG. 4

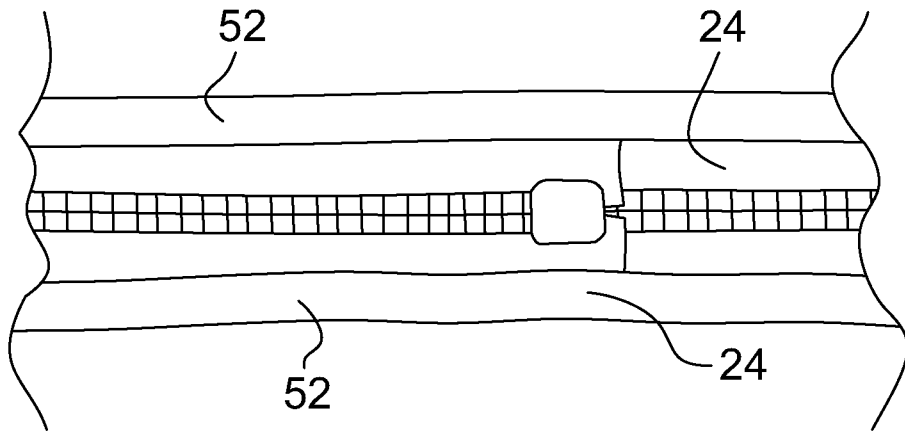

FIG. 5

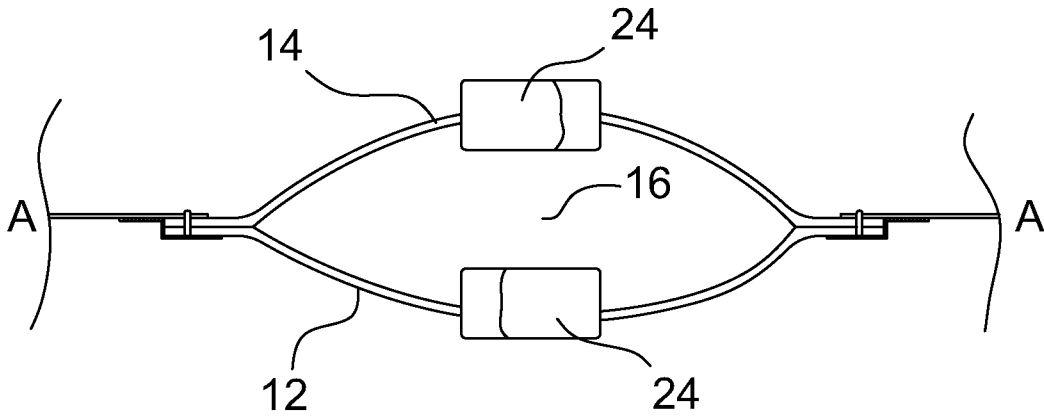

FIG. 6

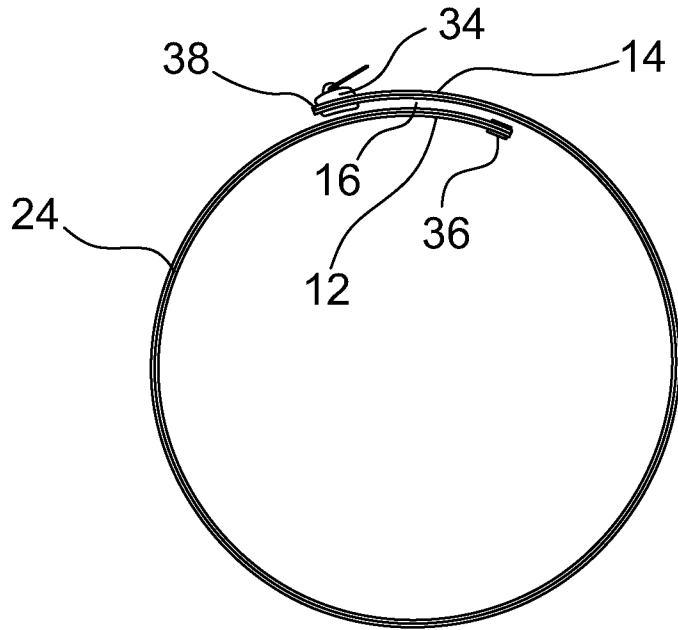

FIG. 7

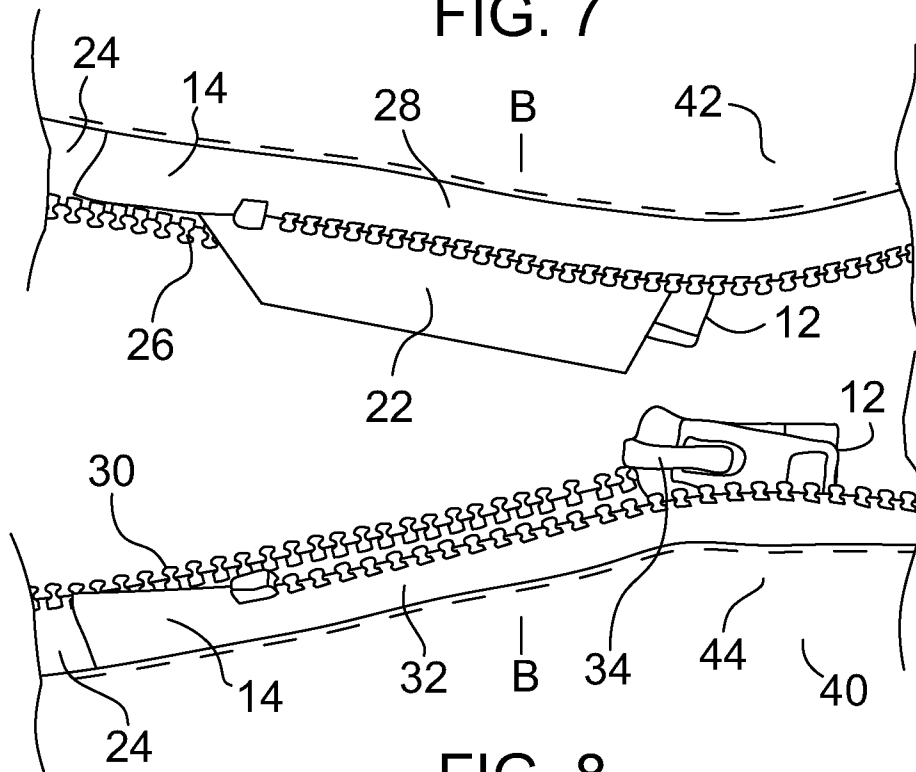

FIG. 8

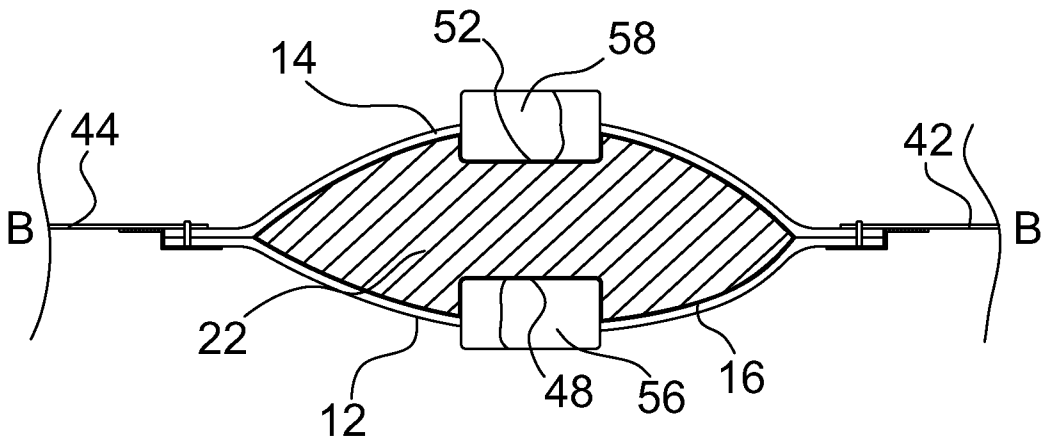

FIG. 9

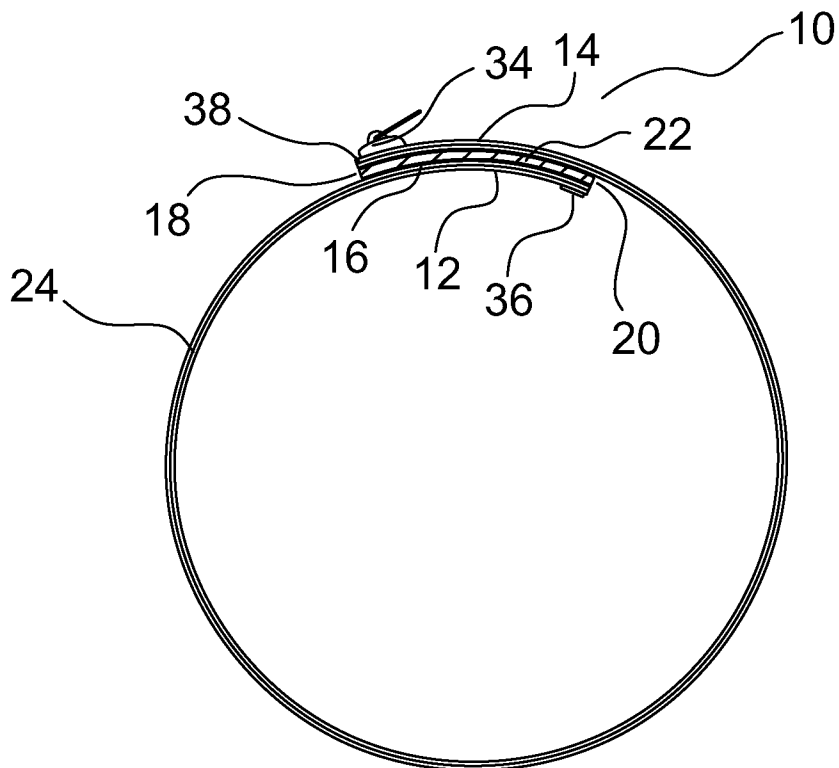

FIG. 10

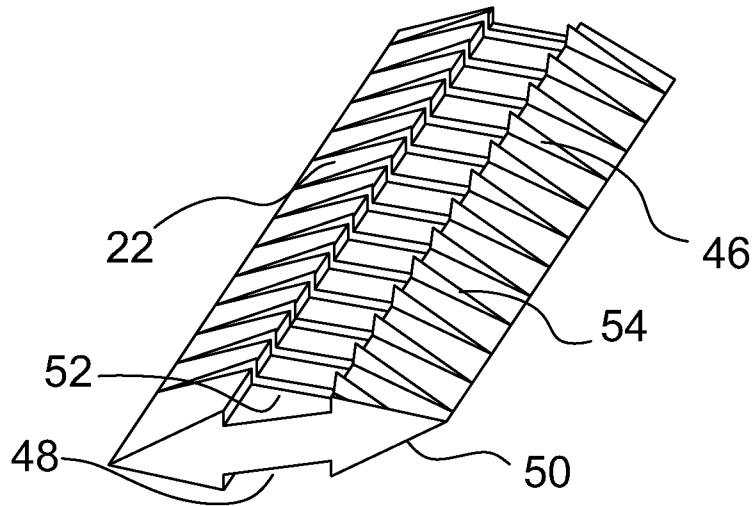

FIG. 11

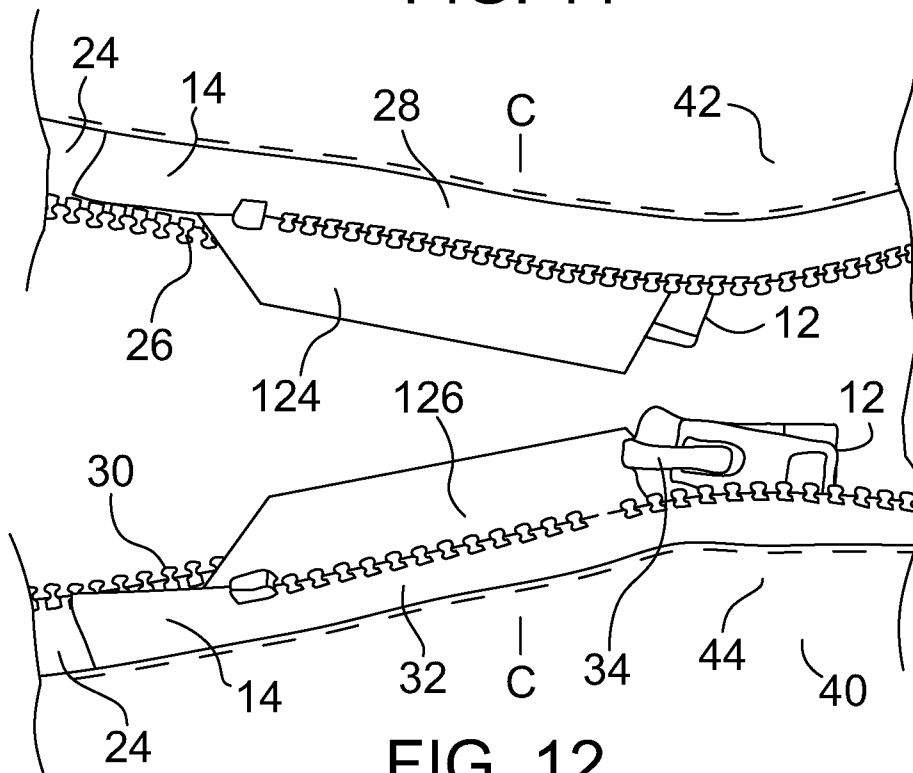

FIG. 12

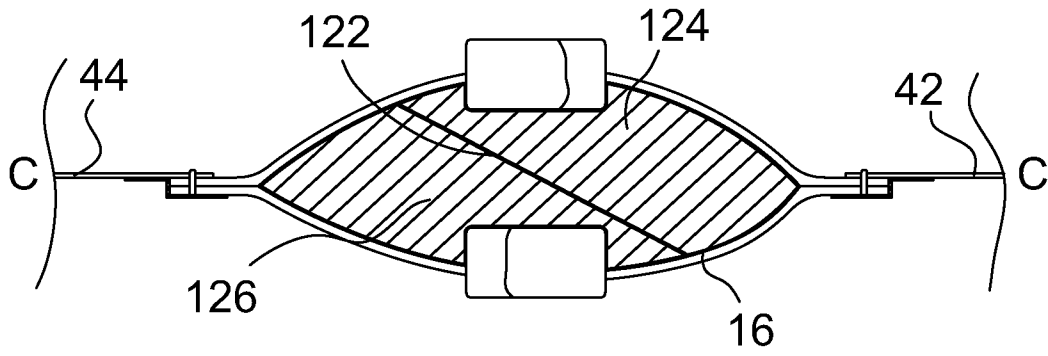

FIG. 13

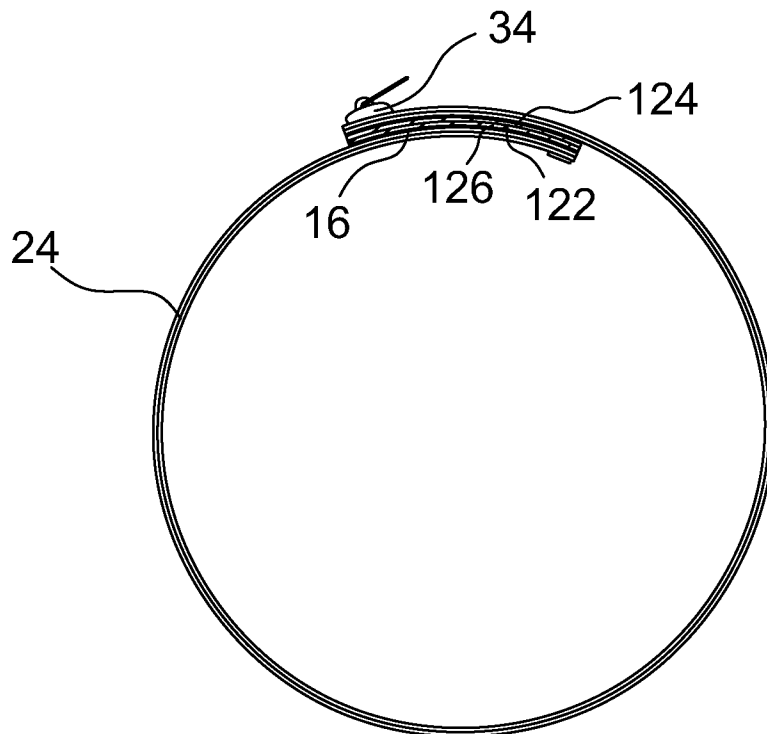

FIG. 14

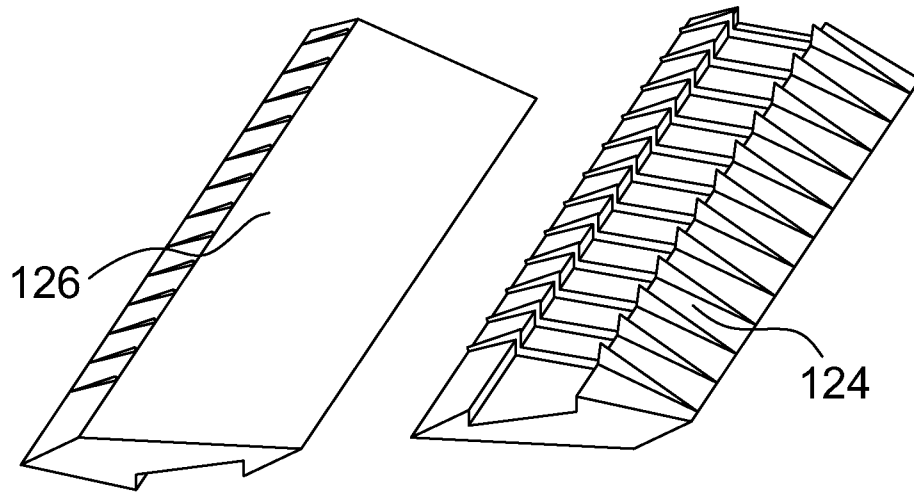

FIG. 15

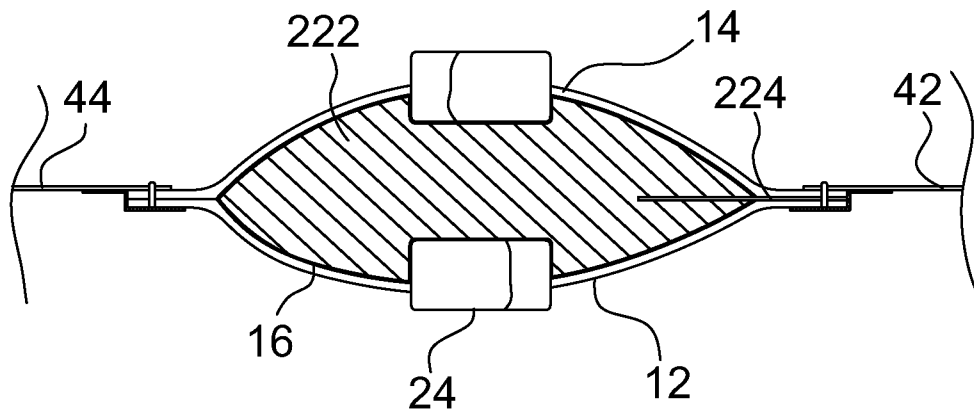

FIG. 16

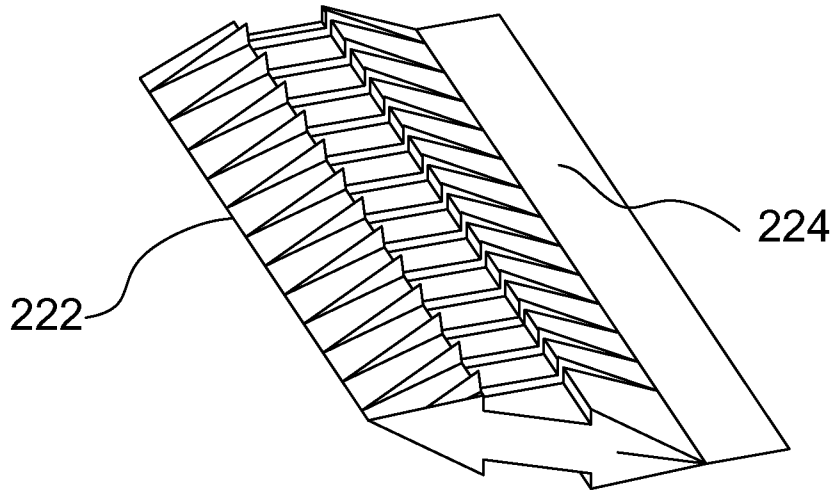

FIG. 17

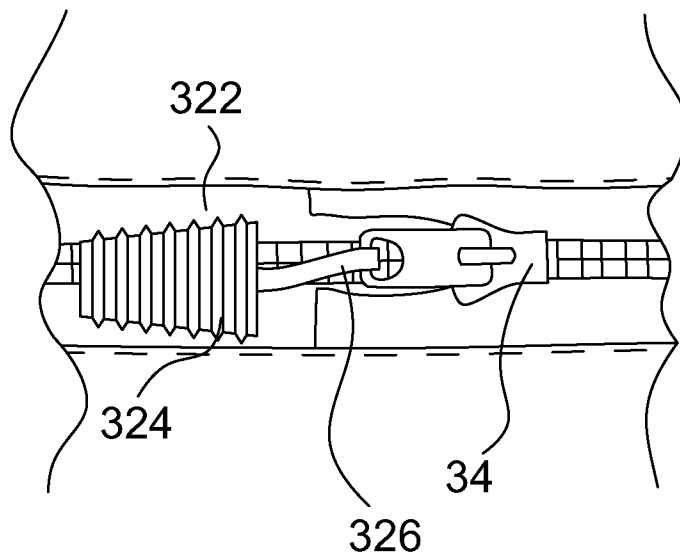

FIG. 18

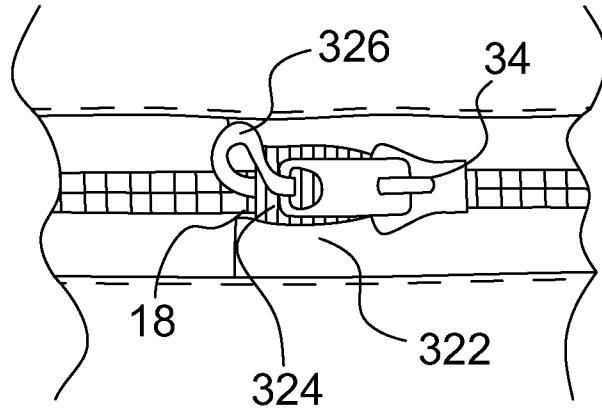

FIG. 19

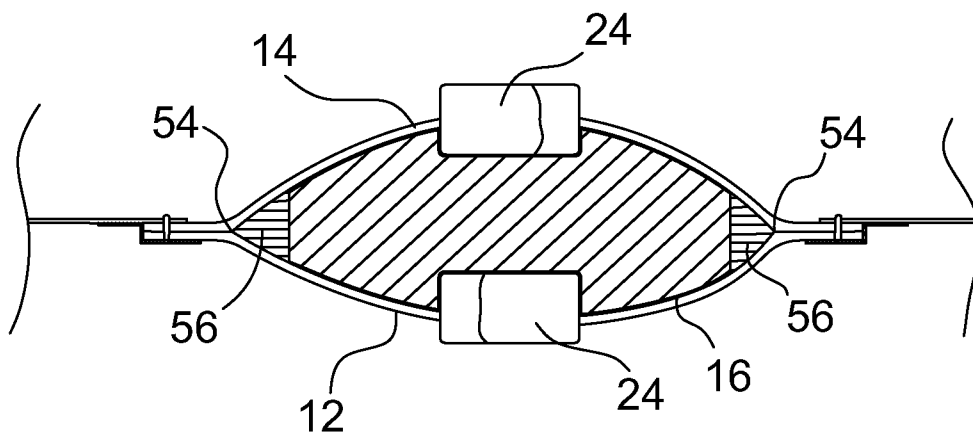

FIG. 20

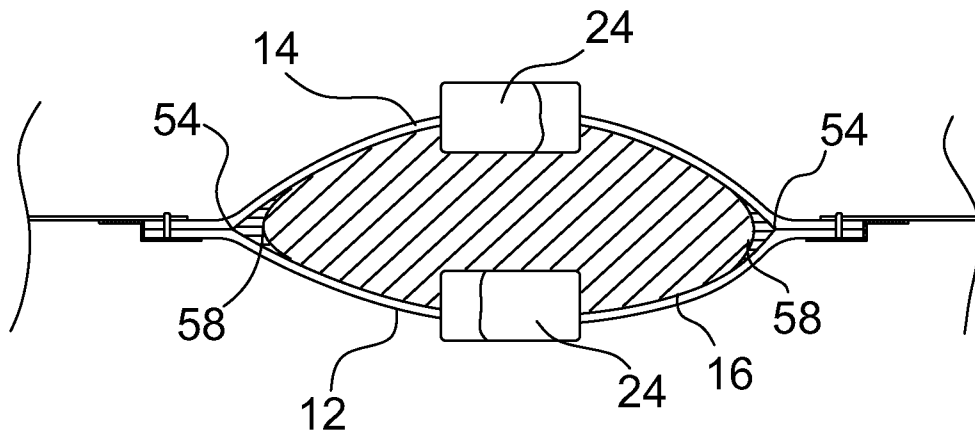

FIG. 21

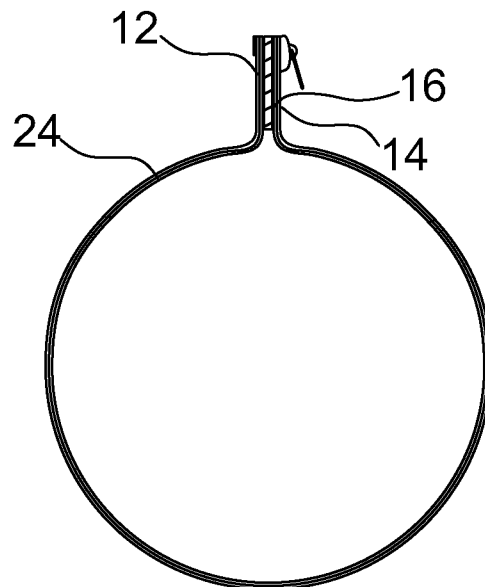

FIG. 22

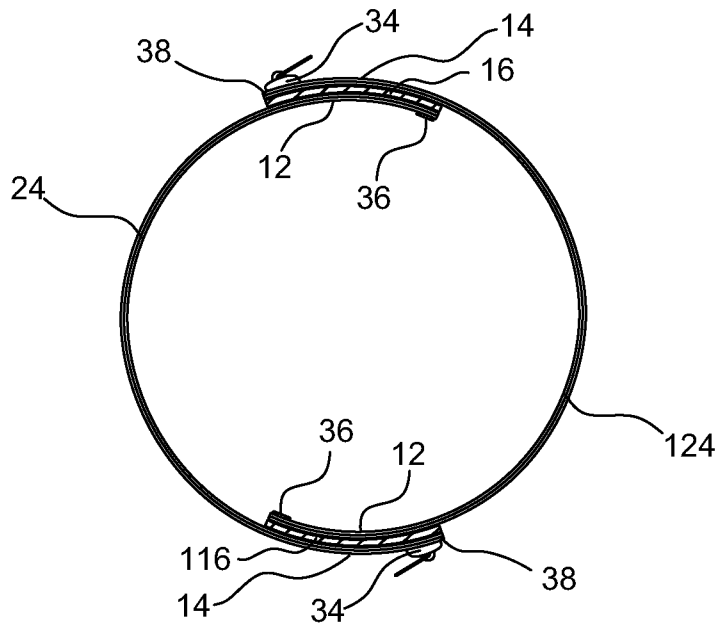

FIG. 23

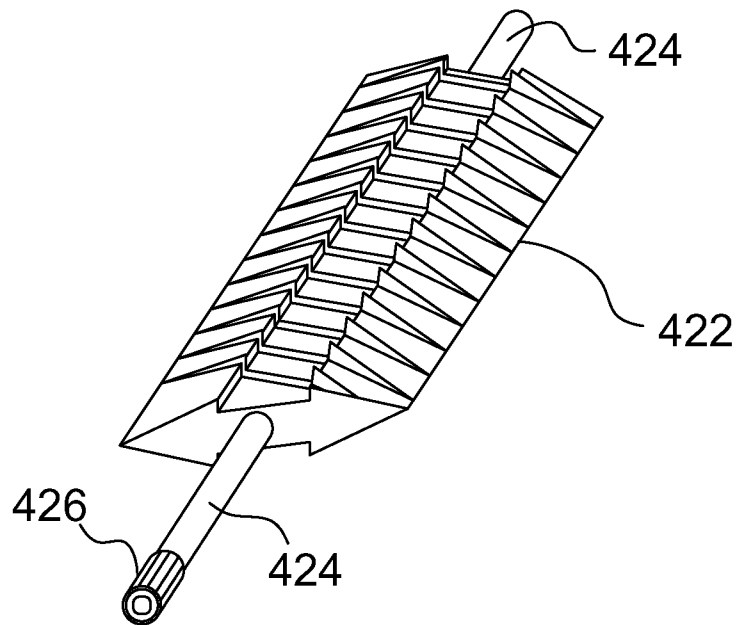

FIG. 24

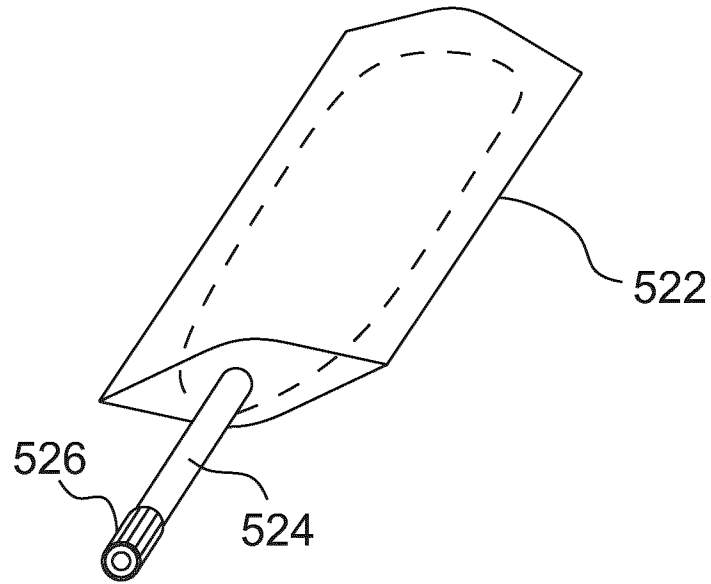

FIG. 25

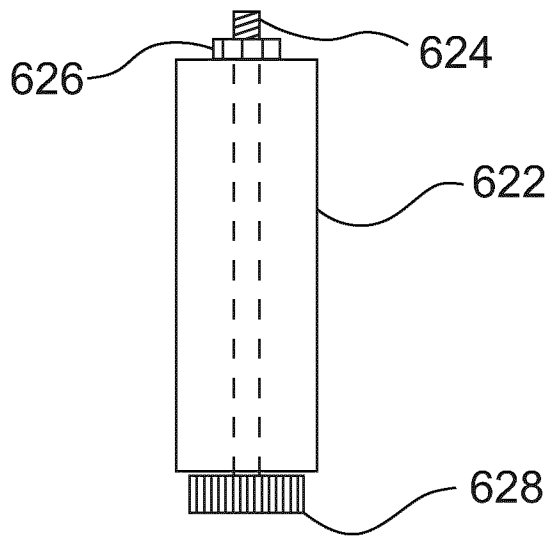

FIG. 26

INTERNATIONAL SEARCH REPORT

International application No.

PCT/CA2017/050477

A. CLASSIFICATION OF SUBJECT MATTER
 IPC: *A44B 19/32* (2006.01), *A44B 19/36* (2006.01)

According to International Patent Classification (IPC) or to both national classification and IPC

B. FIELDS SEARCHED

Minimum documentation searched (classification system followed by classification symbols)
 IPC (2006.01): A44B 16/32

Documentation searched other than minimum documentation to the extent that such documents are included in the fields searched

Electronic database(s) consulted during the international search (name of database(s) and, where practicable, search terms used)

Questel-Orbit: two, second, zip+, expand+, inflat+, plug+, wedge+, tether+, lanyard+, seal+, tube, conduit, duct, valv+, clamp, nut, bolt, knob, squeeze+, press+, forc+, upper, circul+, circl+

C. DOCUMENTS CONSIDERED TO BE RELEVANT

Category*	Citation of document, with indication, where appropriate, of the relevant passages	Relevant to claim No.
X	US3102570, (FAIRCHILDS, B. S.) 03 September 1963 (03-09-1963) *whole document*	1, 3, 6, 7, 9, 10, 11, 13, 14, 16, 19, 20, 22, 23, 24 26
X	US6223349, (ROISER, E.) 01 May 2001 (01-05-2001) *whole document*	1, 2, 7, 9, 10, 11, 13, 14, 15, 20, 22, 23, 24, and 26
A	US2347583, (VARTABEDIAN, K.) 25 April 1944 (25-04-1944) *whole document*	
A	US2454214, (SAPP, J. P.) 16 November 1948 (16-11-1948) *whole document*	
A	US2641037, (GOSSNER, L. E. E.) 09 June 1953 (09-06-1953) *whole document*	

Further documents are listed in the continuation of Box C.

See patent family annex.

* "A" "E" "L" "O" "P"	Special categories of cited documents: document defining the general state of the art which is not considered to be of particular relevance earlier application or patent but published on or after the international filing date document which may throw doubts on priority claim(s) or which is cited to establish the publication date of another citation or other special reason (as specified) document referring to an oral disclosure, use, exhibition or other means document published prior to the international filing date but later than the priority date claimed	"T" "X" "Y" "&"	later document published after the international filing date or priority date and not in conflict with the application but cited to understand the principle or theory underlying the invention document of particular relevance; the claimed invention cannot be considered novel or cannot be considered to involve an inventive step when the document is taken alone document of particular relevance; the claimed invention cannot be considered to involve an inventive step when the document is combined with one or more other such documents, such combination being obvious to a person skilled in the art document member of the same patent family
--------------------------------------	--	--------------------------	--

Date of the actual completion of the international search
 10 May 2017 (10-05-2017)

Date of mailing of the international search report
 25 July 2017 (25-07-2017)

Name and mailing address of the ISA/CA
 Canadian Intellectual Property Office
 Place du Portage I, C114 - 1st Floor, Box PCT
 50 Victoria Street
 Gatineau, Quebec K1A 0C9
 Facsimile No.: 819-953-2476

Authorized officer

Shawn De Salvo (819) 639-7843

INTERNATIONAL SEARCH REPORT

International application No.

PCT/CA2017/050477

C (Continuation). DOCUMENTS CONSIDERED TO BE RELEVANT		
Category*	Citation of document, with indication, where appropriate, of the relevant passages	Relevant to claim No.
A	US2841851, (VAN AMBURG, W. F. et al.) 08 July 1958 (08-07-1958) *whole document*	
A	GB557418, 19 November 1943 (19-11-1943) *whole document*	
A	GB2094396, (ENJALRIC, R.) 15 September 1982 (15-09-1982) *whole document*	

INTERNATIONAL SEARCH REPORT
Information on patent family members

International application No.

PCT/CA2017/050477

Patent Document Cited in Search Report	Publication Date	Patent Family Member(s)	Publication Date
US3102570A	03 September 1963 (03-09-1963)	None	
US6223349B1	01 May 2001 (01-05-2001)	US6223349B1 ATA94599A AT408713B EP1057424A2 EP1057424A3	01 May 2001 (01-05-2001) 15 July 2001 (15-07-2001) 25 February 2002 (25-02-2002) 06 December 2000 (06-12-2000) 10 October 2001 (10-10-2001)
US2347583A	25 April 1944 (25-04-1944)	None	
US2454214A	16 November 1948 (16-11-1948)	None	
US2641037A	09 June 1953 (09-06-1953)	None	
US2841851A	08 July 1958 (08-07-1958)	None	
GB557418A	19 November 1943 (19-11-1943)	None	
GB2094396A	15 September 1982 (15-09-1982)	GB2094396A DE3208026A1 FR2501020A1 FR2501020B1 IT8212457D0 IT1157646B JPS57160404A	15 September 1982 (15-09-1982) 16 September 1982 (16-09-1982) 10 September 1982 (10-09-1982) 16 November 1984 (16-11-1984) 03 March 1982 (03-03-1982) 18 February 1987 (18-02-1987) 02 October 1982 (02-10-1982)