

---

**(12) PATENT ABRIDGMENT (11) Document No. AU-B-38353/89**  
**(19) AUSTRALIAN PATENT OFFICE (10) Acceptance No. 624397**

---

- (54) Title  
**AN APPARATUS FOR WINDING AN INSULATION PLY**
- International Patent Classification(s)  
(51)<sup>4</sup> **F16L 059/02**  
(51)<sup>5</sup> **B65H 018/08 B65H 019/22**
- (21) Application No. : **38353/89** (22) Application Date : **14.06.89**
- (87) PCT Publication Number : **WO89/12776**
- (30) Priority Data
- (31) Number (32) Date (33) Country  
**883043 23.06.88 FI FINLAND**
- (43) Publication Date : **12.01.90**
- (44) Publication Date of Accepted Application : **11.06.92**
- (71) Applicant(s)  
**OY PARTEK AB**
- (72) Inventor(s)  
**OSMO SOIKKELI**
- (74) Attorney or Agent  
**WATERMARK PATENT & TRADEMARK ATTORNEYS , Locked Bag 5, HAWTHORN VIC 3122**
- (56) Prior Art Documents  
**DE 1080827**  
**EP 20574**  
**DE 1571482**
- (57) Claim

1. An apparatus for winding a ply of an insulation material onto a core to form a chute, comprising:

first and second spaced apart support members, said support members being generally parallel to each other and supported for rotating movement about a common axis between a ready position and an operating position;

a moveable endless belt supported for movement along a path located between the support members;

core engaging means located adjacent the support members and moveable relative thereto for engaging empty cores and moving an empty core to a core winding position wherein the cores are generally co-axial with said common axis, and for moving a wound core from the core winding position to a core discharge position; and

a roller mounted on the support members and moveable relative thereto, to engage the endless belt and to move the belt (i) to a position extending around the core in the winding position, wherein the belt guides the insulating material ply onto the cores to form a chute thereon, and (ii) away from the core in the winding position.

PCT

OPI DATE 12/01/90

APPLN. ID 38353 / 89

AOJP DATE 15/02/90

PCT NUMBER PCT/FI89/00115

INTERNATIONAL APPLICATION PUBLISHED UNDER THE PATENT COOPERATION TREATY (PCT)

<b>(51) International Patent Classification 4 :</b> F16L 59/02	A1	<b>(11) International Publication Number:</b> WO 89/12776 <b>(43) International Publication Date:</b> 28 December 1989 (28.12.89) 024397
<b>(21) International Application Number:</b> PCT/FI89/00115 <b>(22) International Filing Date:</b> 14 June 1989 (14.06.89) <b>(30) Priority data:</b> 883043 23 June 1988 (23.06.88) FI <b>(71) Applicant (for all designated States except US):</b> OY PARTEK AB [FI/FI]; SF-21600 Parainen (FI). <b>(72) Inventor; and</b> <b>(75) Inventor/Applicant (for US only) :</b> SOIKKELI, Osmo [FI/FI]; Mäntyläntie 14, SF-53650 Lappeenranta (FI). <b>(74) Agent:</b> OY KOLSTER AB; Stora Robertsgatan 23, P.O. Box 148, SF-00121 Helsinki (FI).	<b>(81) Designated States:</b> AT (European patent), AU, BE (European patent), BG, CH (European patent), DE (European patent), DK, FR (European patent), GB (European patent), HU, IT (European patent), JP, KR, LU (European patent), NL (European patent), NO, RO, SE (European patent), SU, US.  <b>Published</b> With international search report.	

**(54) Title:** AN APPARATUS FOR WINDING AN INSULATION PLY

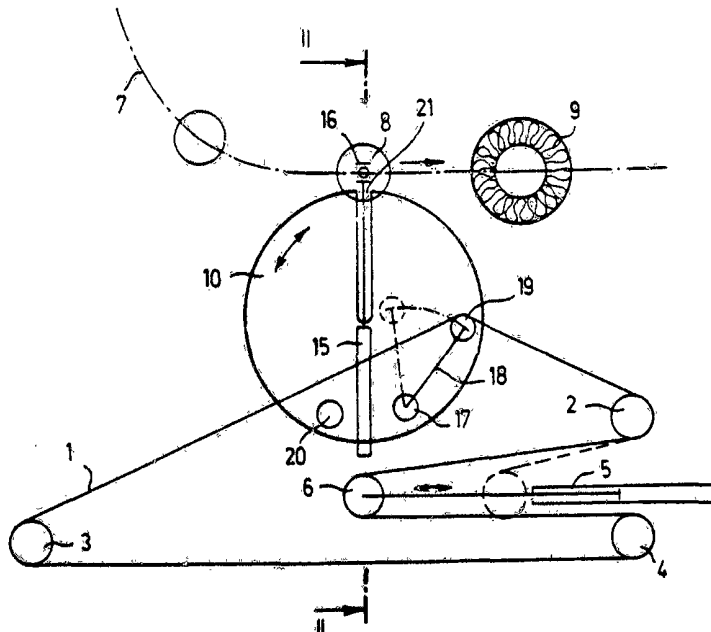

**(57) Abstract**

The invention relates to an apparatus for winding a ply of an insulating material on to a core (8) to form a chute. The apparatus comprises a movable, endless belt (1) which is bent around the core for the time of the winding, so that the insulating material ply is wound between the core and the belt. In order to wind insulating chutes of greatly varying diameter within a space as small as possible, a turnable means (10) is provided outside both edges of the belt in the winding area of the belt, so that they turn perpendicularly to the plane of the belt between a position of readiness and a winding position. The belt (1) is arranged to pass via a roll (19) mounted between said turnable means (10) so as to follow their movement. The roll (19) is displaceable between a receiving/delivering position and a winding position of the core (8). Means (15, 16) are provided in connection with the turnable means (10) for displacing an empty core (8) from the receiving position to the winding position and for displacing a wound core (9) from the winding position to the delivering position.

## An apparatus for winding an insulation ply

This invention relates to an apparatus for winding a ply of an insulating material on to a core to form a chute, comprising a movable, endless belt  
5 arranged to be bent around the core for the time of the winding so that the insulating material ply can be wound on to the core between it and the belt.

The winding of insulating material plies often  
10 forms part of a process for the manufacture of insulating chutes, wherein cores with insulation material wound thereon are cured; the cured insulation is possibly coated with an aluminium foil, for instance; the insulation is sawed open into a chute; and the chutes  
15 are removed from the cores, whereafter the empty cores are recycled to the winding step. In general, the cores are transported by an endless conveyor.

In prior art apparatuses, the winding is carried out while the core is positioned on the conveyor. Previously, the lever movements required for  
20 bending the belt of the winding means around the core have been long and have required plenty of space. Variation in the chute diameter has been possible within very narrow limits only.

25 The object is to provide a new insulation winding apparatus which eliminates the above-mentioned drawbacks and, in particular, is suitable for winding insulation chutes of widely varying diameters.

The winding apparatus according to the invention  
30 is mainly characterized in that in the winding area of the belt, outside both edges of the belt, is provided a means turning perpendicularly to the plane of the belt between a position of readiness and a winding position; that the belt is arranged to pass  
35 via a roll mounted on the turnable means so as to

follow their movement, said roll being displaceable between two positions at different distances from the turning shaft of the turnable means, the position closer to the turning shaft being the winding position of said roll; and that means are provided in connection with the turnable means for displacing an empty core from a receiving position to a winding position and for displacing a wound core from the winding position to a delivering position.

10 In a preferred embodiment, the winding position of the core is in alignment with the turning shaft of the turnable means, whereat the diameter of the wound core can be varied conveniently within wide limits.

15 Further preferred embodiments of the winding apparatus are defined in greater detail in claims 2 to 6; they also appear from the following description, in which a preferred embodiment shown schematically in the attached drawing is referred to, by way of example.

20 Figure 1 is a side view of the winding apparatus.

Figure 2 is a vertical section along the line II-II in Figure 1.

25 Figures 3 to 13 show the main steps of the winding process seen from the side.

In the drawing, the reference numeral 1 designates an endless winding belt; and 2 designates a drive roll for the belt 1. The reference numerals 3 and 4 designate fixedly mounted turning rolls which rotate passively; 5 designates a working cylinder the piston rod of which is provided with a turning roll 6 for maintaining the desired tightness of the belt. The single drive roll 2 could be replaced with, e.g., three drive rolls provided with a common chain drive and arranged principally in the same way as the rolls

30  
35

2, 6 and 4 shown in the drawing, whereby an improved friction transmission is provided when the belt 1 is loose.

5 The reference numeral 7 designates a so called main conveyor commonly used in the manufacture of chutes; 8 designates an empty core transported to the winding apparatus; and 9 designates a core with an insulation wound thereon when it is being transported to a curing step, for instance.

10 The reference numeral 10 designates two discs rotatable on a bearing 12 of a shaft 11 by means of a chain transmission 14 driven by a motor 13. A pneumatic or hydraulic cylinder 15 is fastened to each disc 10, and a support 16 engageable with a journal 8' of the core 8 is provided in the end of the piston rod of each cylinder 15. While resting on the supports, the core 8 is displaceable from the plane of the main conveyor 7 to the plane of the shaft of the discs 10; the last-mentioned position is designated with the reference numeral 8a.

15 Two rolls 17 and 20 are mounted in bearings to the discs 10, and arms 18 are attached to the ends of the shaft of the roll 17. Further, a roll 19 movable between a position close to the periphery of the disc 10 and a position close to the centre of the disc is mounted in bearings to one end of each arm 18. When the roll 19 moves, the roll 17 acts as a joint; the position of the movable roll 19 close to the centre of the disc is indicated with broken lines in Figure 1.

25 The belt 1 moves between the discs.

30 In the following, the main steps of the winding process are described with reference to Figures 3 to 13.

35 In Figure 3, the situation is the same as in Figure 1, that is, an empty core 8 has arrived at the

winding means and it has been displaced on to the supports 16 at the end of the piston rods of the lifting cylinders 15, whereafter the cylinders 15 start to displace the core towards the centre of the discs 10.

5           After the core 8 has been displaced to the position shown in Figure 4, it is stopped momentarily, whereafter the discs 10 start to turn anti-clockwise, while the movement of the core towards the centre of the discs is continued.

10           In Figure 5, the discs 10 have turned through  $90^\circ$ , and the core 8 is positioned about midway between the periphery and the centre of the discs. The belt 1 makes contact with the core 8, and the roll 17 likewise makes contact with the belt 1.

15           In Figure 6, the discs have turned through  $180^\circ$ , and the core 8 has been displaced to the centre of the discs 10, that is, preferably in alignment with the turning shafts 11 of the discs. The roll 20 mounted to the discs 10 makes contact with the belt 1.

20           In Figure 7, the roll 19 has been displaced towards the centre of the discs, into contact with the core 8.

          Thereafter the winding of a ply 22 of a wool material is started as shown in Figure 8, whereby the  
25           roll 19 yields. The roll 19 can be moved, e.g., by means of a pneumatic cylinder not shown in the drawing, and a predetermined counterpressure may prevail in the pneumatic cylinder. The winding is continued until a desired thickness is achieved, whereafter the  
30           ply is cut off. The desired thickness can be determined, e.g., on the basis of the displacement of the belt, or if a thin chute is to be obtained, the ply can be cut into a determined length in advance.

          In Figure 9, the winding process has been completed, and the discs 10 start to turn clockwise, and  
35

the cylinders 15 displace the core with an insulation 9' back towards the periphery of the discs 10, as appears from Figures 10 to 13. In the position of Figure 12, the displacing movement stops momentarily, and the  
5 discs 10 stop, whereafter the cylinders 15 lift the core 8 with the insulation 9' back on to the conveyor 7.

The turning angle of the discs 10 varies with the diameter of the core. If the diameter of the core  
10 8 is small, the turning angle of the discs varies from about  $130^{\circ}$  to about  $150^{\circ}$  when the core is in the winding position near to or in alignment with the shafts 11 of the discs 10. With large-diameter cores, the turning angle of the discs 10 correspondingly varies  
15 from about  $210^{\circ}$  to about  $240^{\circ}$ . The turning angle of  $180^{\circ}$  of the discs in the drawing is possible with one specific core diameter only. The turning angle of the discs is a determined function of the core diameter, and the turning angles for different core diameters  
20 can be precomputed. Further, the stopping of the discs at the right position in each particular case can be ensured by means of an angle gauge known per se.

THE CLAIMS DEFINING THE INVENTION ARE AS FOLLOWS:

1. An apparatus for winding a ply of an insulation material onto a core to form a chute, comprising:

first and second spaced apart support members, said support members being generally parallel to each other and supported for rotating movement about a common axis between a ready position and an operating position;

a moveable endless belt supported for movement along a path located between the support members;

core engaging means located adjacent the support members and moveable relative thereto for engaging empty cores and moving an empty core to a core winding position wherein the cores are generally co-axial with said common axis, and for moving a wound core from the core winding position to a core discharge position; and

a roller mounted on the support members and moveable relative thereto, to engage the endless belt and to move the belt (i) to a position extending around the core in the winding position, wherein the belt guides the insulating material ply onto the cores to form a chute thereon, and (ii) away from the core in the winding position.

2. An apparatus according to Claim 1, wherein:

the support members rotate through a given angle as the support members rotate from the ready position to the operating position;

and the value of the given angle increases as the diameters of the empty cores increase.

3. An apparatus according to Claim 1, wherein the core engaging means is mounted on the first and second support members and is adapted to move the cores to and away from the core winding position while the support members rotate between the ready and operating positions.

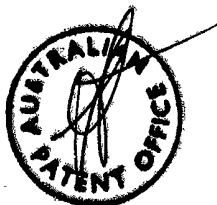

4. An apparatus as claimed in Claim 1, substantially as herein described with reference to the accompanying drawings.

DATED this 17th day of March, 1992

OY PARTEK AB

WATERMARK PATENT & TRADEMARK ATTORNEYS  
THE ATRIUM  
290 BURWOOD ROAD  
HAWTHORN VICTORIA 3122  
AUSTRALIA

1  
2  
3  
4  
5  
6  
7  
8  
9  
10  
11  
12  
13  
14  
15  
16  
17  
18  
19  
20  
21  
22  
23  
24  
25  
26  
27  
28  
29  
30  
31  
32  
33  
34  
35  
36  
37  
38  
39  
40  
41  
42  
43  
44  
45  
46  
47  
48  
49  
50

51  
52  
53  
54  
55  
56  
57  
58  
59  
60

61  
62  
63  
64  
65  
66  
67  
68  
69  
70

71  
72  
73  
74  
75  
76  
77  
78  
79  
80

AU3835389.WPC(DOC.013) / RCTS:EK





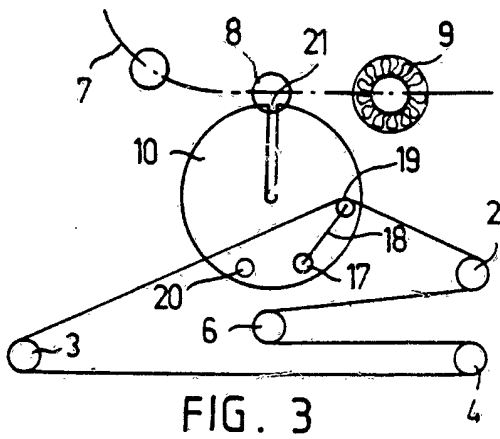

FIG. 3

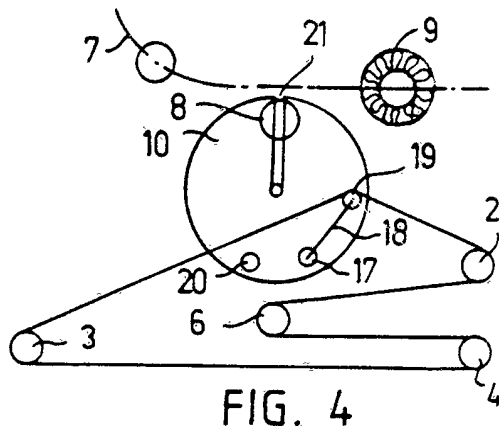

FIG. 4

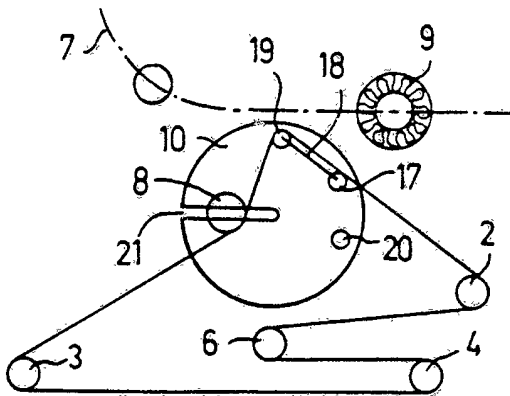

FIG. 5

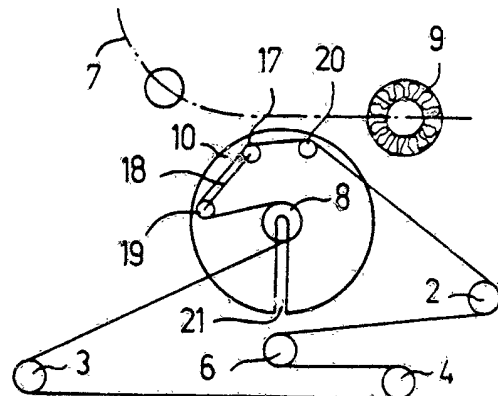

FIG. 6

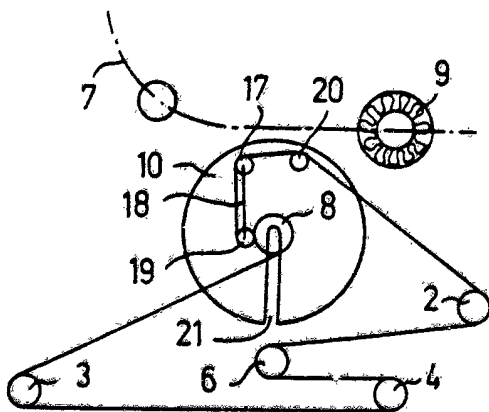

FIG. 7

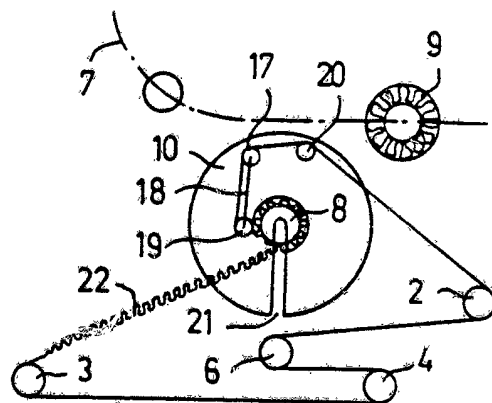

FIG. 8

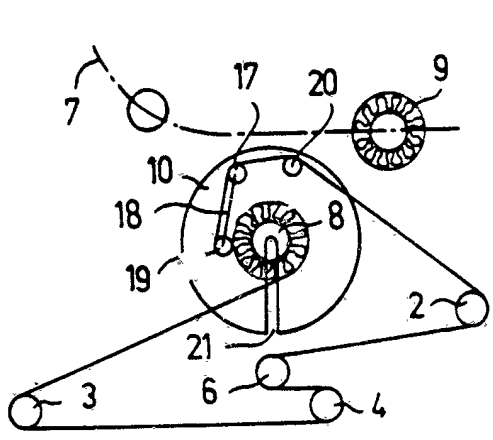

FIG. 9

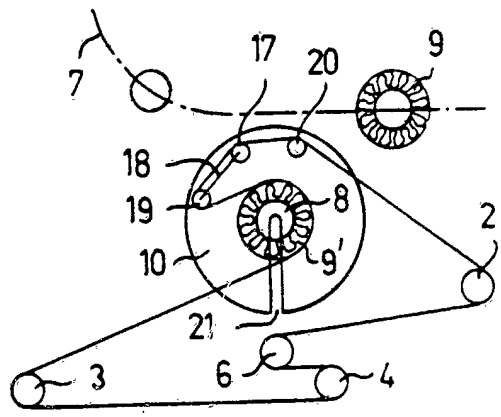

FIG. 10

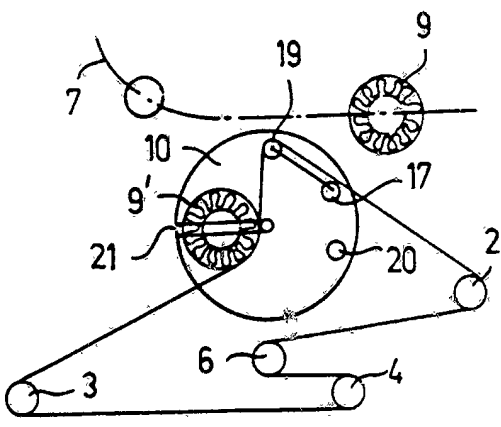

FIG. 11

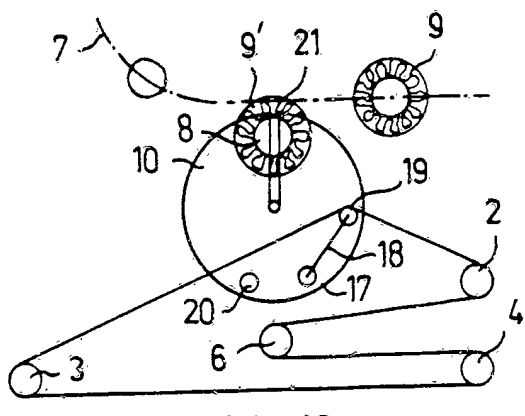

FIG. 12

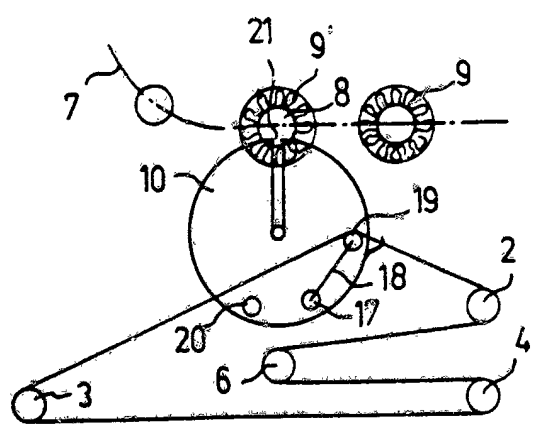



FIG. 13

# INTERNATIONAL SEARCH REPORT

International Application No PCT/FI89/00115

<b>I. CLASSIFICATION OF SUBJECT MATTER</b> (if several classification symbols apply, indicate all) *		
According to International Patent Classification (IPC) or to both National Classification and IPC 4		
F 16 L 59/02		
<b>H. FIELDS SEARCHED</b>		
Minimum Documentation Searched 7		
Classification System	Classification Symbols	
IPC 4	F 16 L 59/00, /02, /04, /14	
US C1	138:129,131,144-149; 156:443,446,450	
Documentation Searched other than Minimum Documentation to the Extent that such Documents are Included in the Fields Searched 8		
SE, NO, DK, FI classes as above.		
<b>III. DOCUMENTS CONSIDERED TO BE RELEVANT 9</b>		
Category *	Citation of Document, 11 with indication, where appropriate, of the relevant passages 12	Relevant to Claim No. 13
X Y	DE, B1, I 080 827 (GUSTIN-BACON MANUFACTURING COMPANY, INC) 28 April 1960 See column 2, line 44 - column 3, line 22, column 4 line 56 - column 5, line 7 and figures 1 and 3.	1-6 1-6
X Y	EP, A1, 0 205 714 (ISOVER SAINT-GOBAIN) 30 December 1986 See page 8 line 38 - page 10, line 20 and figure 2 & FR, 2583498 JP, 61290003 US, 4830808	1-6 1-6
Y	DE, A1, 1 571 482 (FA. FRANCISOL) 12 February 1970 See page 11, lines 9-16 and figure 4 & NL, 6614135 BE, 687799  .../...	1-6
<p>* Special categories of cited documents: 10</p> <p>"A" document defining the general state of the art which is not considered to be of particular relevance</p> <p>"E" earlier document but published on or after the international filing date</p> <p>"L" document which may throw doubts on priority claim(s) or which is cited to establish the publication date of another citation or other special reason (as specified)</p> <p>"O" document referring to an oral disclosure, use, exhibition or other means</p> <p>"P" document published prior to the international filing date but later than the priority date claimed</p> <p>"T" later document published after the international filing date or priority date and not in conflict with the application but cited to understand the principle or theory underlying the invention</p> <p>"X" document of particular relevance; the claimed invention cannot be considered novel or cannot be considered to involve an inventive step</p> <p>"Y" document of particular relevance; the claimed invention cannot be considered to involve an inventive step when the document is combined with one or more other such documents, such combination being obvious to a person skilled in the art.</p> <p>"A" document member of the same patent family</p>		
<b>IV. CERTIFICATION</b>		
Date of the Actual Completion of the International Search	Date of Mailing of this International Search Report	
1989-09-25	1989-09-27	
International Searching Authority	Signature of Authorized Officer	
Swedish Patent Office	 Erik Svensson	

III. DOCUMENTS CONSIDERED TO BE RELEVANT (CONTINUED FROM THE SECOND SHEET)		
Category *	Citation of Document, with indication, where appropriate, of the relevant passages	Relevant to Claim No
Y	SE, C, 206 757 (ROCKWOOL AB) 9 August 1966 See page 2, column 1, lines 12-36, column 2, lines 22-24 and figure 2 details 88,89,91'' and 101-108	1-6