



(12) **EUROPEAN PATENT APPLICATION**

(43) Date of publication:
05.08.1998 Bulletin 1998/32

(51) Int. Cl.⁶: **F02D 41/14**

(21) Application number: **98105227.7**

(22) Date of filing: **09.11.1994**

(84) Designated Contracting States:
DE ES FR GB SE

• **Serra, Gabriele**
40068 S. Lazzaro Di Savena (IT)

(30) Priority: **12.11.1993 IT TO930857**

(74) Representative:
Prato, Roberto et al
STUDIO TORTA S.r.l.,
Via Viotti 9
10121 Torino (IT)

(62) Document number(s) of the earlier application(s) in accordance with Art. 76 EPC:
94117678.6 / 0 657 637

(71) Applicant:
MAGNETI MARELLI S.p.A.
20145 Milano (IT)

Remarks:

This application was filed on 23 - 03 - 1998 as a divisional application to the application mentioned under INID code 62.

(72) Inventors:
• **Biagini, Luca**
42019 Scandiano (IT)

(54) **Electronic system for calculating mixture strength**

(57) System for calculating mixture strength in which an electronic panel (7) is capable of comparing the voltage generated by exhaust gas sensors, in particular from a lambda probe (19) located in the exhaust manifold (21) of a petrol engine (4), with a threshold value (Str) such as to distinguish between a first and a

second state (rich state/lean state), corresponding to an air/petrol mixture supplied to the engine which contains more or less petrol, respectively, than is required by the stoichiometric ratio. The system enables this threshold to be updated periodically.

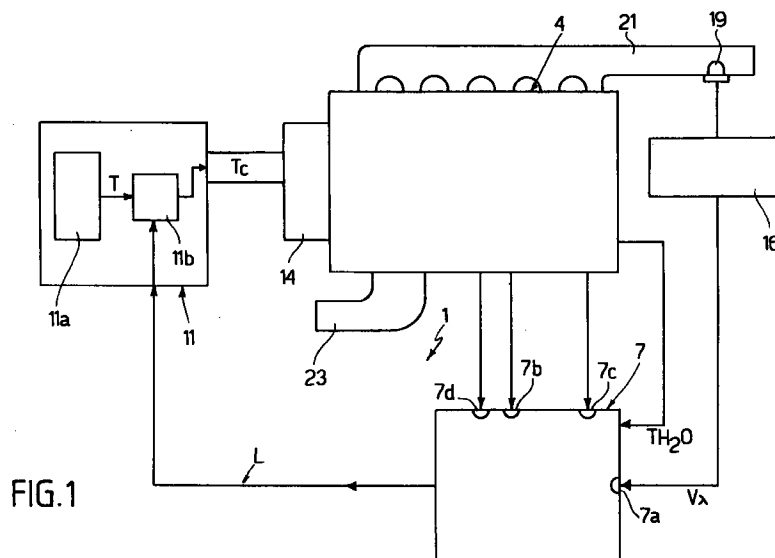

FIG.1

Description

The present invention relates to an electronic system for calculating mixture strength.

5 Electronic systems are known for calculating mixture strength in which an electronic panel with a microprocessor receives as input a series of information signals measured in the engine (for example, signals proportional to the quantity of fuel supplied to the engine, to the temperature of the air drawn into the engine, to the temperature of the water in the engine cooling system, etc.), and processes these signals to generate in open loop a control time T for the injection device.

10 This time T is corrected by means of a reaction signal from exhaust gas sensors, in particular a lambda probe located in the engine's exhaust manifold, the function of which is to monitor the strength of the air/petrol mixture supplied to the engine.

The signal generated by the lambda probe is substantially digital in nature and therefore assumes two different states (high/low) corresponding to an air/petrol mixture supplied to the engine that contains respectively more or less petrol than is required by the stoichiometric ratio (rich mixture/lean mixture).

15 Electronic systems of the known type compare the voltage generated by the lambda probe with a lower and an upper reference threshold in order to determine the status of the probe and therefore the strength (rich or lean) of the mixture supplied to the engine.

However, these systems are extremely complicated and costly.

20 The thresholds used in the known systems, moreover, are fixed voltages independent of the amplitude of the signal generated by the lambda probe; for these reasons, any fluctuations in the amplitude of the signal generated by the lambda probe may give rise to errors.

The purpose of this invention is to create a system that will overcome the drawback of the known systems and utilize a dynamic type of threshold.

This purpose is achieved by the present invention in that it relates to a system as described in Claim 1.

25 The invention will now be illustrated with particular reference to the attached figures which present a preferred, non-limiting embodiment and in which:

Figure 1 illustrates in schematic form an internal-combustion engine equipped with an electronic system for calculating the mixture strength produced according to the procedures of the present invention;

30 Figures 2a, 2b, 2c, 2d and 2e show a block diagram of the operations carried out by the system of the present invention;

Figures 3 and 4a, 4b illustrate particular details of the block diagram shown in Figures 2a-2e; and

Figure 5 illustrates the changes in the time of the signal generated by a lambda probe utilized in the system according to the present invention.

35 In Figure 1, the number 1 indicates the overall electronic system for calculating the strength of the air/petrol mixture supplied to an internal-combustion engine 4, specifically a petrol engine (represented schematically).

40 The system 1 includes an electronic panel with a microprocessor 7, which receives a number of information signals from the engine 4 and works in conjunction with an electronic injection control panel 11 that controls a fuel injection device 14 (shown schematically), coupled to the engine 4.

In particular, the electronic panel 7 has a first input 7a which is connected through an interface circuit 16 (of a known type) with exhaust gas sensors, in particular a lambda probe 19 located in the exhaust manifold 21 of the engine 4.

45 The panel 7 also has second, third and fourth inputs 7b, 7c, 7d connected to sensors (not shown) which read, respectively, the temperature TH₂O of the engine 4 cooling fluid, the number of revolutions (rpm) of the engine 4 and the position of the butterfly valve (not shown) of the engine 4.

The panel 7 conducts a periodic test of the lambda probe 19 and generates an output signal L that contains substantial information on the state of the probe and on the stoichiometric composition of the exhaust gas.

In particular, the signal L generated by the panel 7 reports the following information:

- 50
- probe O.K./probe not O.K.;
 - probe failed/probe not failed;
 - air/petrol mixture supplied to the engine has more petrol than required by the stoichiometric ratio (rich state);
 - air/petrol mixture supplied to the engine has less petrol than required by the stoichiometric ratio (lean state);
 - 55 - authorization to quickly increase the percentage of petrol in the mixture (fast enrichment);
 - authorization to quickly increase the percentage of air in the mixture (fast thinning).

The panel 11 receives a number of input information signals (for example, number of engine revolutions, tempera-

ture of air drawn in through the intake manifold 23 of the engine 4, temperature of the engine 4 cooling fluid, position of the engine butterfly valve, etc.) and develops, through a calculation circuit 11a (of known type) an open loop injection time T. The open loop injection time T is supplied to a correction circuit 11b which modifies (in a known manner) this time T on the basis of the information L from the panel 7, generating a closed loop injection time Tc that is supplied to the fuel injection device 14.

Figure 2 is a block diagram of the operations carried out by the panel 7 of the electronic system according to the present invention.

The process starts with a block 100 capable of reading that the engine 4 has been turned on (KEY-ON); if the engine 4 starts, the process moves from block 100 to a block 110; otherwise, the system remains on hold.

The block 110 initializes a variable L that describes the state of the lamoda probe and the stoichiometric composition of the air/petrol mixture supplied to the engine; in particular, the probe state variable is set as: probe not failed not O.K.

The block 110 is followed by a block 120 in which a variable Str (transition probe variable) is initialized; in particular, the variable Str is set equal to a stored calibration value, namely Str=calibration value.

In block 120, the variable T1 of a first counter (not shown) is initialized and set equal to a stored calibration value, i.e. T1=calibration value.

The block 120 is followed by a block 130 that reduces the variable T1 for each stroke of the engine.

The block 130 is followed by a block 140 that compares the value of the variable T1 with a threshold value; if these values are not equal, the system goes back from block 140 to block 130; otherwise it moves to a block 150.

The block 150 sets the probe state variable as: probe not failed not O.K.

The blocks 100-140 define a first system state known as the starting state. The system 1 remains in this state in order to obtain heating of the lamoda probe and initialization of a number of variables of the system.

The starting state is exited after a preset number of engine strokes (block 140), in other words at the end of a preset time after the engine 4 has been turned on and the lambda probe has warmed up.

The block 150 is followed by a block 160 in which the variable T2 of a second counter (not shown) is initialized and set equal to a calculated calibration value (for example, by means of a table) as a function of the temperature of the water in the engine cooling system, i.e. T2=calibration value (as a function of TH₂O).

The block 160 is followed by a block 170 in which the Vlambda voltage generated by the lambda probe is read.

The block 170 is followed by a block 180 in which the Vlambda voltage value previously read is compared with the present value of the transition threshold variable Str; in particular, if the Vlambda voltage is greater than the transition threshold Str (Vlambda > Str), the system moves from block 180 to a block 190 (corresponding to a "rich" state detailed below); otherwise, it goes to a block 200 that reduces the content of the second counter.

The block 200 is followed by a block 210 in which the Vlambda voltage value previously read is compared with a threshold that is substantially equal to zero; in particular, if the Vlambda voltage is substantially equal to zero, the system moves from block 210 to a block 220; otherwise, it goes to a block 230.

In block 220, the number of engine accelerations Nacc is checked; if the Nacc number is less than a calibration value, the system goes from block 220 to block 230; otherwise, it goes to a block 240 ("failure" state) that sets the lambda state variable as: probe not failed not O.K.

The block 230 compares the value of the variable T2 with a threshold value; if these values are not equal, the system goes back from block 230 to block 170; otherwise it goes to a block 250 (corresponding to a "lean" state detailed below) which sets the probe state variable as: not failed, O.K. lean.

The blocks 150-230 define a second system state, known as the operational idle state. In this state, a first test is conducted on the voltage generated by the lambda probe (block 180) in order to identify a voltage higher than the transition threshold Str and corresponding to an air/petrol mixture which has more petrol than required by the stoichiometric ratio (rich state).

In this state a lamoda probe malfunction situation is also identified, a situation due for example to a break in the connections between the panel 7 and the said lambda probe. This malfunction situation is identified if the voltage generated by the probe is substantially equal to zero (block 210), despite the fact that the engine has accelerated a preset number of times (block 220); in this case, the air/petrol mixture has shifted to the "rich" state and the failure to note this state is, therefore, an indication of a malfunction.

Switchover from the optional idle state to the lean state (block 250) takes place if, after a preset number of engine strokes (block 230), a voltage higher than the threshold (block 180) is not read, or no malfunction of the type described above is found.

The block 190 is followed by a block 300 in which a Vmax-ric variable is initialized, representing the maximum value of the voltage read on the lambda probe while it is in the "rich" state.

In block 300 a counter CNT_KO2 (not shown) is also initialized, the content of which is increased by a preset unit with each engine stroke.

The block 300 is followed by a block 310 in which the Vlambda voltage generated by the lambda probe is read.

The block 310 is followed by a block 320 in which the V_{λ} voltage value read is compared with the present value of the $V_{\max-ric}$ variable; in particular, if the V_{λ} voltage measured is greater than the current maximum voltage value ($V_{\lambda} > V_{\max-ric}$), the system moves from block 320 to a block 330 which updates the $V_{\max-ric}$ variable, setting the maximum voltage value read on the lambda probe equal to the value previously measured ($V_{\max-ric}=V_{\lambda}$); otherwise, it moves to a block 340 (detailed below) which sends control signals to the panel 11 to reduce the percentage of petrol in the air/petrol mix (thinning of the mixture).

The block 340 is followed by a block 370 in which the V_{λ} voltage value previously noted is compared with the current value of the transition threshold variable Str ; in particular, if the V_{λ} voltage is lower than the transition threshold Str ($V_{\lambda} < Str$), the system goes from block 370 to a block 375; otherwise, it goes to a block 380.

The block 375 checks a variable Ctr which represents the number of transitions of state of the lambda probe; in particular, if the variable Ctr is equal to (or greater than) one, in other words, if there has been at least one transition from the rich state to the lean state, the system moves from block 375 to a block 390; otherwise, it returns to block 370.

The block 390 updates the transition threshold Str and is followed by a block 400 in which the variable Ctr is reset to zero ($Ctr=0$).

The block 400 is then followed by the "lean" state block 250 which sets the lambda probe state variable to: not failed, O.K. lean.

In block 380, a counter CNT_COFF of engine strokes that remain in cut-off (supply interruption) is initialized; in particular, if the engine remains in the cut-off state for a preset number of strokes and the V_{λ} voltage is over the threshold, the system goes from block 380 to block 240; otherwise, it goes to a block 430.

In block 430, the content of counter CNT_KO2 (not shown) is compared with a threshold value n ; if the content of the counter matches this threshold value n , in other words, if n engine cycles have occurred since going into the rich state and there has been no changeover to the lean state, the system moves from block 430 to block 240 (failure state); otherwise, it returns to block 310.

The blocks 190, 300-430 define a third system state known as the "rich" state; the system remains in this state when the air/petrol mixture has more petrol than required by the stoichiometric ratio.

In this state, a test is periodically conducted (block 370) on the voltage generated by the lambda probe in order to identify a voltage below the transition threshold Str (corresponding to an air/petrol mixture that has less petrol than is required by the stoichiometric ratio) and to move to the lean state.

In the event of a transition between the "rich" state and the "lean" state, the transition threshold (block 390) is updated.

In the rich state, the strength (thinning of the air/petrol mixture, block 340) is corrected and two malfunction situations are also identified. The first malfunction situation is found (block 380) if the engine is in cut-off state (fuel supply interruption and, therefore, a necessarily "lean" mixture) and at the same time a V_{λ} voltage above the threshold is found, corresponding in other words to a "rich" mixture fed to the engine.

The second malfunction situation is found if, for n engine cycles in the rich state (block 430) no switchover to the lean state has occurred; in other words, if the system remains indefinitely in the rich state despite the reduction in the petrol percentage produced by block 340 (mixture thinning), it can be assumed that the switchover to the lean state was not recognized by the probe and that the probe has therefore failed.

The block 250 is followed by a block 500 in which a $V_{\min-mag}$ variable, representing the lowest voltage reading on the lambda probe while in the "lean" state, is initialized.

Moreover, a counter CNT_KO2 (not shown) is initialized in block 500, the content of this counter being increased by a preset unit with each engine stroke.

The block 500 is followed by a block 510 in which the V_{λ} voltage generated by the lambda probe is read.

The block 510 is followed by a block 520 in which the V_{λ} voltage read is compared with the current value of the $V_{\min-mag}$ variable; in particular, if the V_{λ} voltage measured is less than the current minimum value of the $V_{\min-mag}$ voltage ($V_{\lambda} < V_{\min-mag}$), the system goes from block 520 to a block 550 that updates the $V_{\min-mag}$ variable, setting $V_{\min-mag}=V_{\lambda}$; otherwise, the system goes to a block 540 (detailed below) which sends control signals to the panel 11 to increase the percentage of petrol in the air/petrol mixture enrichment of mixture).

The block 540 is followed by a block 570 in which the V_{λ} voltage value previously read is compared with the current value of the transition threshold variable Str ; in particular, if the V_{λ} voltage is greater than the transition threshold Str ($V_{\lambda} > Str$), the system goes from block 570 to a block 575; otherwise, it goes to a block 580.

In block 575, the variable Ctr is increased by one unit following the transition of state; the system then returns again from block 575 to block 190 (rich state).

In block 580, the content of the counter CNT_KO2 (not shown) is compared with a threshold value m ; if the content of the counter matches this threshold value m , in other words, if m engine cycles have taken place since going into the rich state and there has been no switchover to the lean state, the system goes from block 580 to block 240 (failure state); otherwise, it returns to block 510.

The blocks 250, 500-580 define a fourth system state known as the "lean" state; the system remains in this state

when the air/petrol mixture has less petrol than required by the stoichiometric ratio.

In this state, a test is periodically conducted (block 570) on the voltage generated by the lambda probe in order to identify a voltage greater than the transition threshold Str (corresponding to an air/petrol mixture with more petrol in it than required by the stoichiometric ratio) and to move to the "rich" state.

5 In the event of a transition from the "lean" state to the "rich" state, the transition threshold is not updated.

In this state, the strength is corrected (enriching of the air/petrol mixture, block 540) and a malfunction situation is also identified.

10 This malfunction situation is found if for m engine cycles in the lean state (block 580), there has not been any switchover to the rich state; in other words, if the system remains indefinitely in the lean state despite the increase in the petrol percentage produced by block 540 (mixture enrichment), it can be assumed that the switchover to the rich state was not noted by the probe and that the probe has therefore failed.

In block 240, the state variable L is set as: probe O.K. and failed.

The block 240 is followed by a block 610 in which the transition counter is reset to zero, i.e. Ctr=0.

The block 610 is followed by a block 615 in which the Vlambda voltage generated by the probe is read.

15 The block 615 is followed by a block 620 in which the system checks whether the Vlambda voltage passes through the threshold value; if not, it remains in idle and the system returns to block 615; otherwise, it goes to a block 630 which increases the variable Ctr by one unit following the transition.

20 The block 630 is followed by a block 640 in which the content of the variable Ctr is compared with a threshold value C1; if the variable Ctr exceeds the threshold value C1, the system goes from block 640 to a block 650; otherwise, it returns to block 615.

In block 650, the value of the Vlambda voltage is compared with the current threshold value Vst; if the Vlambda voltage exceeds the Vst threshold, the system goes to a block 660, otherwise it goes to a block 670. In blocks 660 and 670, the counter Ctr is reset to zero; also, the system goes from these blocks 660 and 670 to blocks 190 and 250, respectively.

25 The blocks 240, 610-670 define a probe malfunction state (failure state).

30 Exiting from the failure state is possible only after the lambda probe has switched over a preset number of times (block 640) after going into the failure state. Indeed, entry into the failure state occurs when the lambda probe continues to furnish the same value (high or low) constantly, despite the fact that the changed operating conditions of the engine indicate a switching of the signal from the probe. For this reason, when the probe starts switching again, this indicates that the probe has returned to normal operation.

Figure 3 illustrates in detail block 390 which updates the transition threshold Str.

The block 390 consists of a first block 392 in which a term is calculated, known as a transition fraction (FTR), as follows:

35
$$FTR = (V_{maxric} - V_{minmag}) * \text{coeff-trans} / \text{cost} + V_{minmag}$$
 in which Vmaxric and Vminmag are, respectively, the maximum and minimum values of the voltage generated by the lambda probe in the "rich" and "lean" cycles (read by blocks 330, 550) and coeff-trans and cost are two numerical coefficients obtained experimentally.

The block 392 is followed by a block 394 in which the transition function FTR thus calculated is compared with the transition threshold Str currently in use.

40 In particular, if the transition function is greater than the transition threshold (FTR>Str), the system goes from block 394 to a block 396; otherwise (FTR<Str), it goes to a block 398.

The block 396 corrects the transition threshold by increasing by one unit the current digital value of the threshold, as follows:

45
$$\text{Str (new)} = \text{Str (in use)} + 1 \text{ (bit)}.$$

The block 398 corrects the transition threshold by decreasing by one unit the current digital value of the threshold, as follows:

50
$$\text{Str (new)} = \text{Str (in use)} - 1 \text{ (bit)}.$$

The system then moves from blocks 396 and 398 to block 400.

The block 340 is illustrated in detail with particular reference to Figure 4a.

55 The block 340 contains a first block 342 which reads the transition time Ttr1 (Figure 5) taken by the decreasing voltage of the lambda probe 19 to go from a first and higher value equal to Vmaxric less a parameter sgl1, to a second value equal to the transition threshold Str.

The block 342 is followed by a block 344 in which the transition time Ttr1 as previously calculated is compared with a threshold value t1; in particular, if the transition time Ttr1 is less than the threshold t1 (Ttr1<t1), the system goes from block 344 to a block 346; otherwise (Ttr1>t1), it goes to a block 348.

The block 346 sends control signals to the electronic panel 11 authorizing it to reduce gradually the percentage of petrol in the mixture, while block 348 sends control signals to the electronic panel 11 authorizing it to reduce quickly (fast thinning) the percentage of petrol in the mixture.

5 The system then goes from blocks 346 and 348 to block 370. The block 340 makes it possible to modulate the speed with which the

percentage of petrol is decreased (thinning of the mixture) in the air/petrol mixture.

Indeed, in the event that the thinning of the mixture occurs too slowly, the transition time T_{r1} is greater than the transition threshold; this situation is recognized by block 344, which therefore selects block 348 in which the thinning occurs more quickly.

10 The block 540 is illustrated in detail with particular reference to Figure 4b.

The block 540 includes a first block 542 which reads the transition time T_{tr2} taken by the rising voltage of the probe to go from a first and lower value equal to V_{minmag} plus a parameter $sgl2$, to a second value, equal to the transition threshold.

15 The block 542 is followed by a block 544 in which the transition time T_{tr2} as previously calculated is compared with a threshold value $t2$; in particular, if the transition time T_{tr2} is greater than the threshold $t2$ ($T_{tr2} > t2$), the system goes from block 544 to a block 548; otherwise ($T_{tr2} < t2$), it goes to a block 546.

The block 546 sends control signals to the electronic panel 11 authorizing it to increase gradually the percentage of petrol in the mixture while block 548 sends control signals to the electronic panel 11 authorizing it to increase quickly the percentage of petrol in the mixture.

20 The system then goes from blocks 346 and 348 to block 570.

The block 540 makes it possible to modulate the speed with which the percentage of petrol (mixture enrichment) is increased in the air/petrol mixture.

25 Indeed, in the event that the enrichment of the mixture occurs too slowly, the transition time T_{r2} is greater than the transition threshold $t2$; this situation is recognized by block 544 which thus selects block 548 in which the enrichment occurs more quickly.

From what has been indicated above, the advantages of the present invention over known systems are evident.

The system 1, in fact, uses a single transition threshold Str to search for the "rich" state and the "lean" state. The threshold is moreover "dynamic", since it is periodically updated and adapted on the basis of the signal generated by the lambda probe.

30 The system 1 makes it possible accurately to identify five different states (start, operational idle, rich, lean and failure), and to identify a number of malfunction situations.

The system 1 also makes it possible to speed up an excessively slow "thinning" or "enrichment".

Finally, it is clear that modifications and variations may be made to the system described above without thereby departing from the scope of protection of the invention itself.

35

Claims

1. Electronic system for calculating mixture strength, comprising:

- 40
- an electronic unit (7) receiving at least one input signal generated by exhaust gas sensors, in particular by a lambda probe located in the exhaust manifold (21) of an internal-combustion engine (4);
 - the said electronic unit (7) being capable of generating a sensor state signal (L) that reports information on the stoichiometric composition of the air/petrol mixture supplied to the said engine (4);
 - the said electronic unit (7) working in conjunction with an electronic injection control panel (11) that in use calculates an open loop injection time (T) and also modifies the said open loop injection time (T) by means of the said state signal (L) in order to generate a closed loop injection time (T_c); the said electronic unit (7) including means (120, 390) capable of generating a reference threshold (Str) and means of comparison (180, 370, 570) that can compare the signal (V_{lambda}) generated by the said exhaust gas sensors, in particular from the said lambda probe, with the said reference threshold (Str) in order to select alternately electronic means that determine a rich state, corresponding to an air/petrol mixture supplied to the engine which has more petrol than required by the stoichiometric ratio, and electronic means that determine a lean state, corresponding to an air/petrol mixture supplied to the engine which contains less petrol than required by the stoichiometric ratio;
- 45
- 50

55 the said electronic panel also comprising means of correction (390) which in use dynamically modify the said threshold (Str) on the basis of values (V_{maxric} , V_{minmag}) of the signal generated by the said exhaust gas sensors, in particular by the said lambda probe, identified in the said rich and lean states, characterized by the fact that the said electronic unit comprises means for starting (100, 110, 120, 130, 140) that in use recognize a state in which the said exhaust gas sensors, in particular the said probe, are heated;

the said starting means (100, 110, 120, 130, 140) comprising means (100) capable of recognizing that the said engine (4) has been turned on; and first counting means (130, 140) that can count the engine strokes following the said startup and can enable exit from the said heating state by identifying a preset number of engine strokes.

5

2. System according to Claim 1, characterized by the fact that the said starting means comprise means of initializing (120) the said transition threshold (Str).

10

3. System according to Claims 1 or 2, characterized by the fact that the said electronic unit has means of operational idling (150, 160, 170, 180, 200, 210, 220, 230) capable of being selected upon exit from the said starting means (100, 110, 120, 130, 140);

the said means of operational idling comprising first means of comparison (180) capable of comparing a value read (170) (Vlambda) for the signal of the said exhaust gas sensors, and in particular of the said probe, with the said transition threshold (Str);

15

the said first means of comparison (180) being able to control access to the said electronic means that determine the rich state if the said value read (Vlambda) exceeds the said threshold (Vst).

20

4. System according to Claim 3, characterized by the fact that the said means of operational idling comprise second counting means (200, 230) that can count the engine strokes following entry into the said operational idle state, and that can enable exit from the said operational idle state towards the said means for defining the lean state by identifying a preset number of engine strokes.

25

5. System according to Claim 3 or 4, characterized by the fact that the said means of operational idling comprise second means of comparison (210) capable of comparing a value read (170) (Vlambda) for the signal from the said exhaust gas sensors, in particular the said probe, with a reference threshold substantially equal to zero;

the said second means of comparison (210) enabling access to first reading means (220) if the said value read (Vlambda) is substantially equal to the said threshold;

the said first reading means (220) being able to recognize a preset number of accelerations of the said engine in order to control access to means that define a state of malfunction if the said number exceeds a threshold value.

30

6. System according to any one of the preceding claims, characterized by the fact that the said means capable of defining the said rich state comprise second reading means (380, 430) capable of identifying an interruption in the fuel supply (CUT_OFF) to the said engine;

35

the said second reading means (380, 430) being able to control access to means defining a state of malfunction if, during the fuel cut off, the said voltage generated by the said exhaust gas sensors, in particular the said probe, remains greater than the said threshold value.

40

7. System according to Claims 5 or 6, characterized by the fact that the said means capable of identifying a malfunction condition comprise third counting means (620, 630) capable of counting the number of transitions of the said signal generated by the said exhaust gas sensors, and in particular the said lambda probe, through the said threshold (Str);

the said means capable of reading a state of malfunction, also comprising third means of comparison (640), that can compare the said number of transitions with a preset number (C1) and can also control exit from the said state of malfunction when the said preset number is exceeded.

45

8. System according to Claim 7, characterized by the fact that the said means capable of recognizing a malfunction condition comprise fourth means of comparison (650), following the said third means of comparison (640), which can compare the said signal generated by the said exhaust gas sensors, in particular by the said lambda probe, with the said reference threshold;

50

the said fourth means of comparison (650) being capable of allowing access to the said electronic means defining the said lean state if the said value read (Vlambda) is below the said threshold (Vst) and also able to allow access to the said electronic means defining the said rich state if the said value read (Vlambda) exceeds the said threshold (Vst).

55

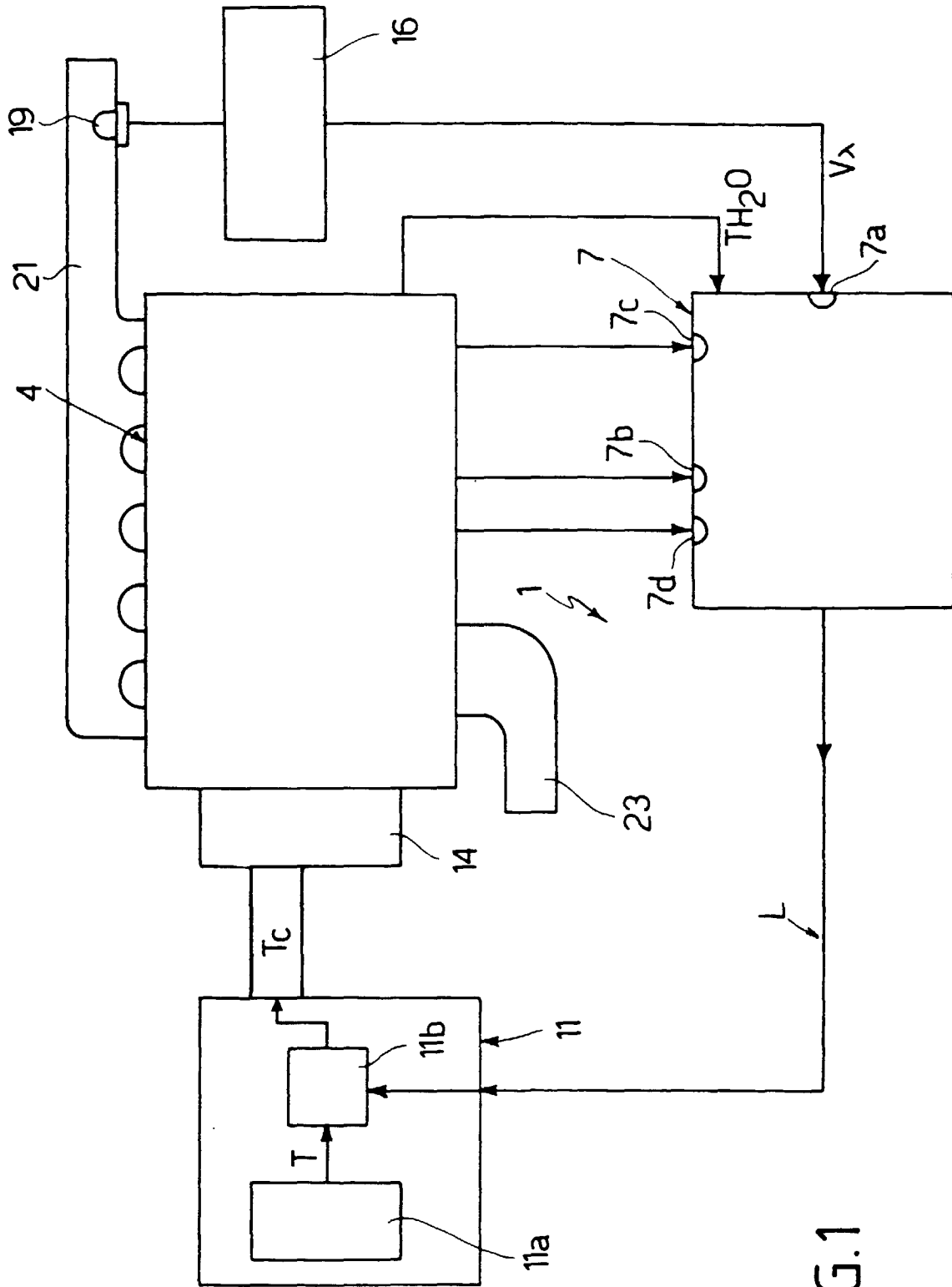

FIG.1

FIG. 2a

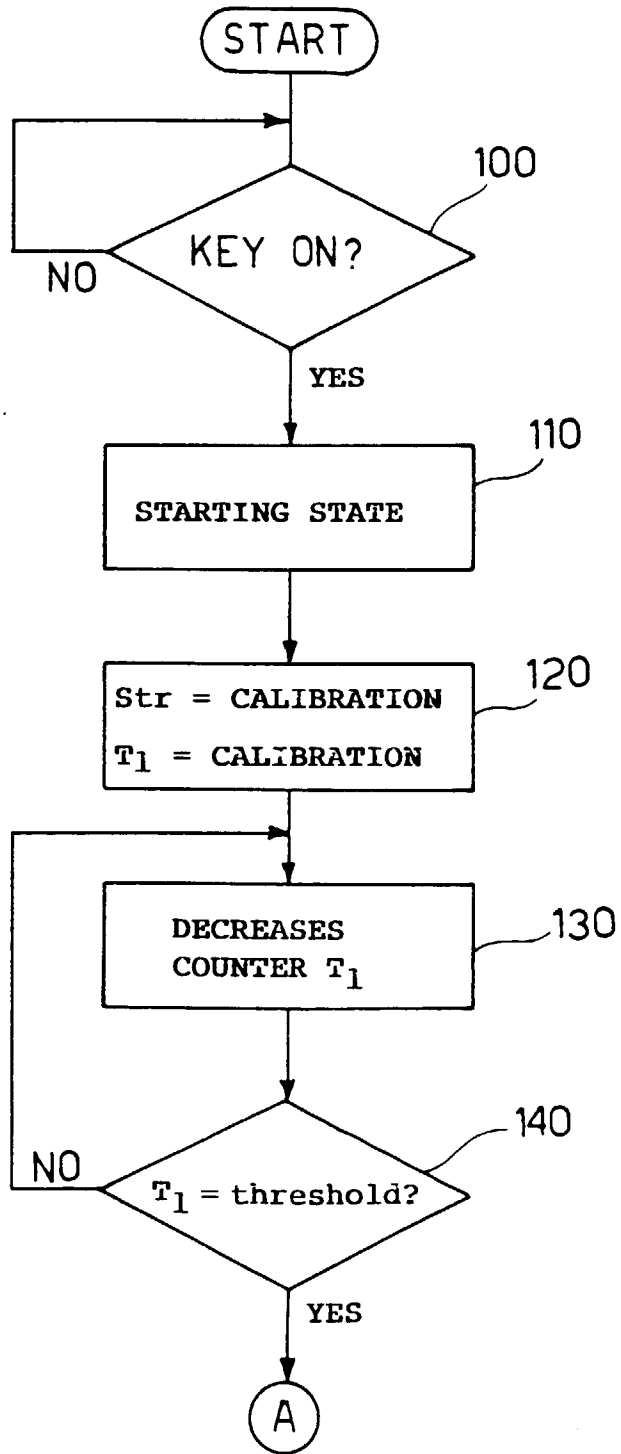
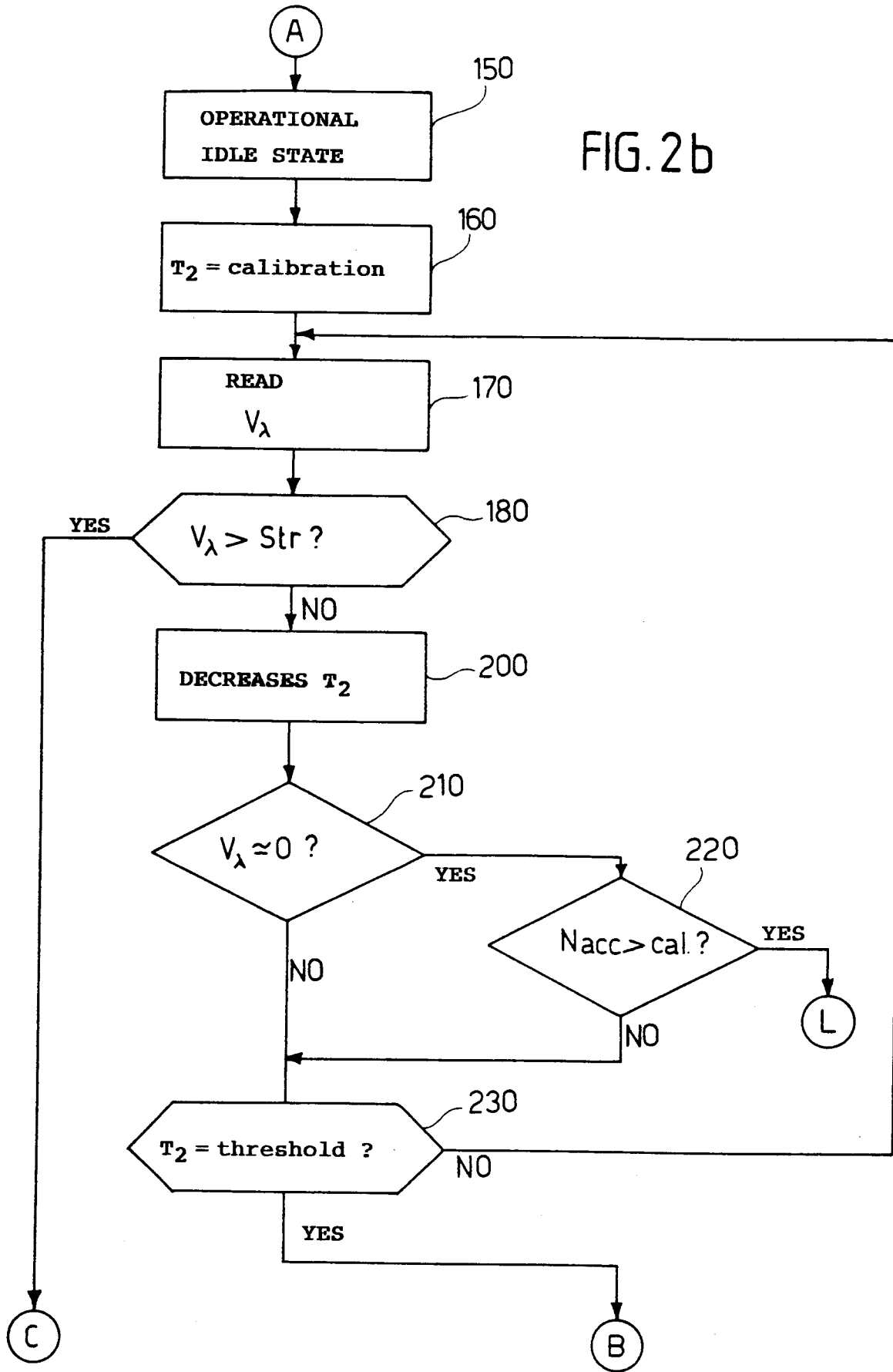
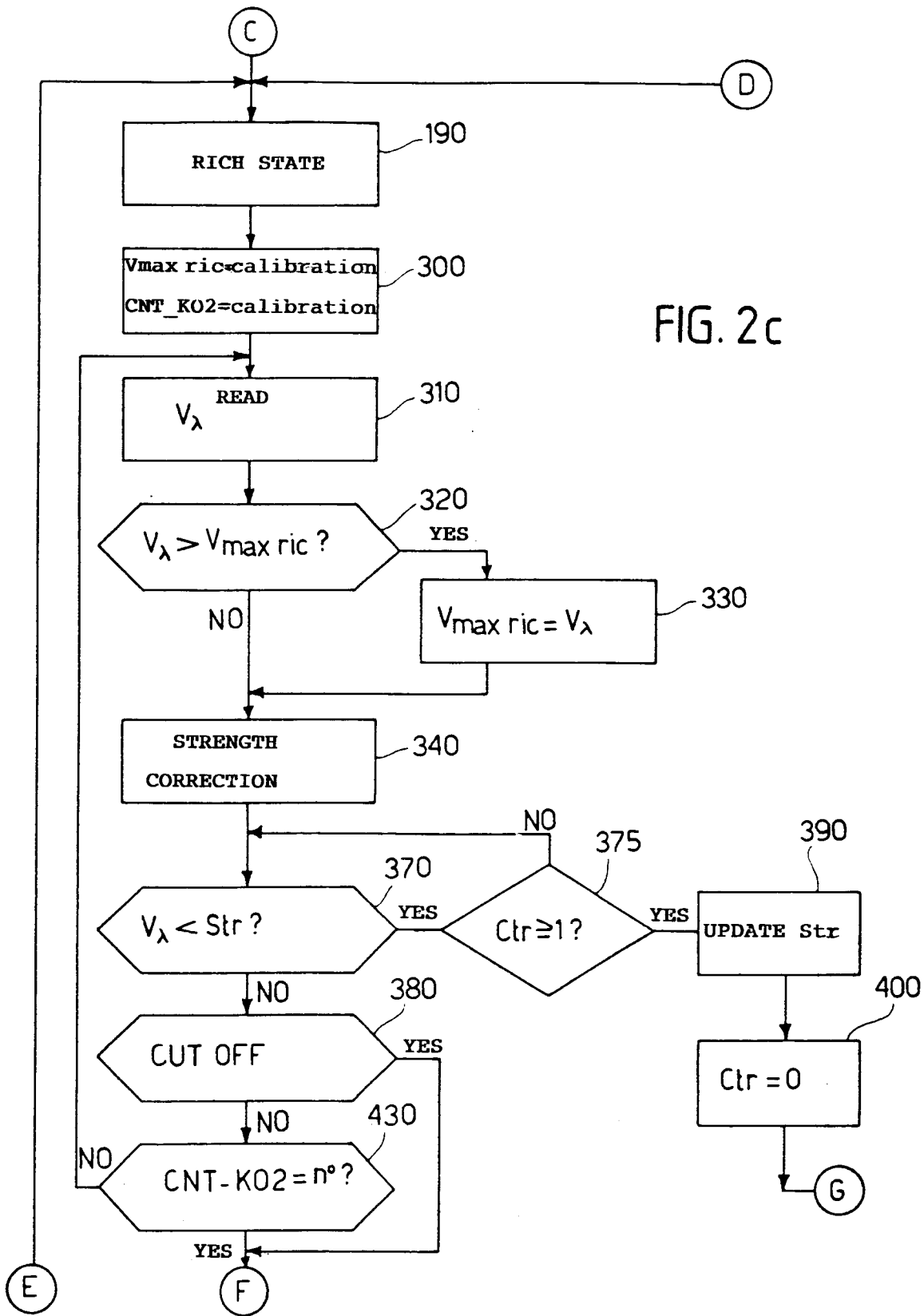

FIG. 2b





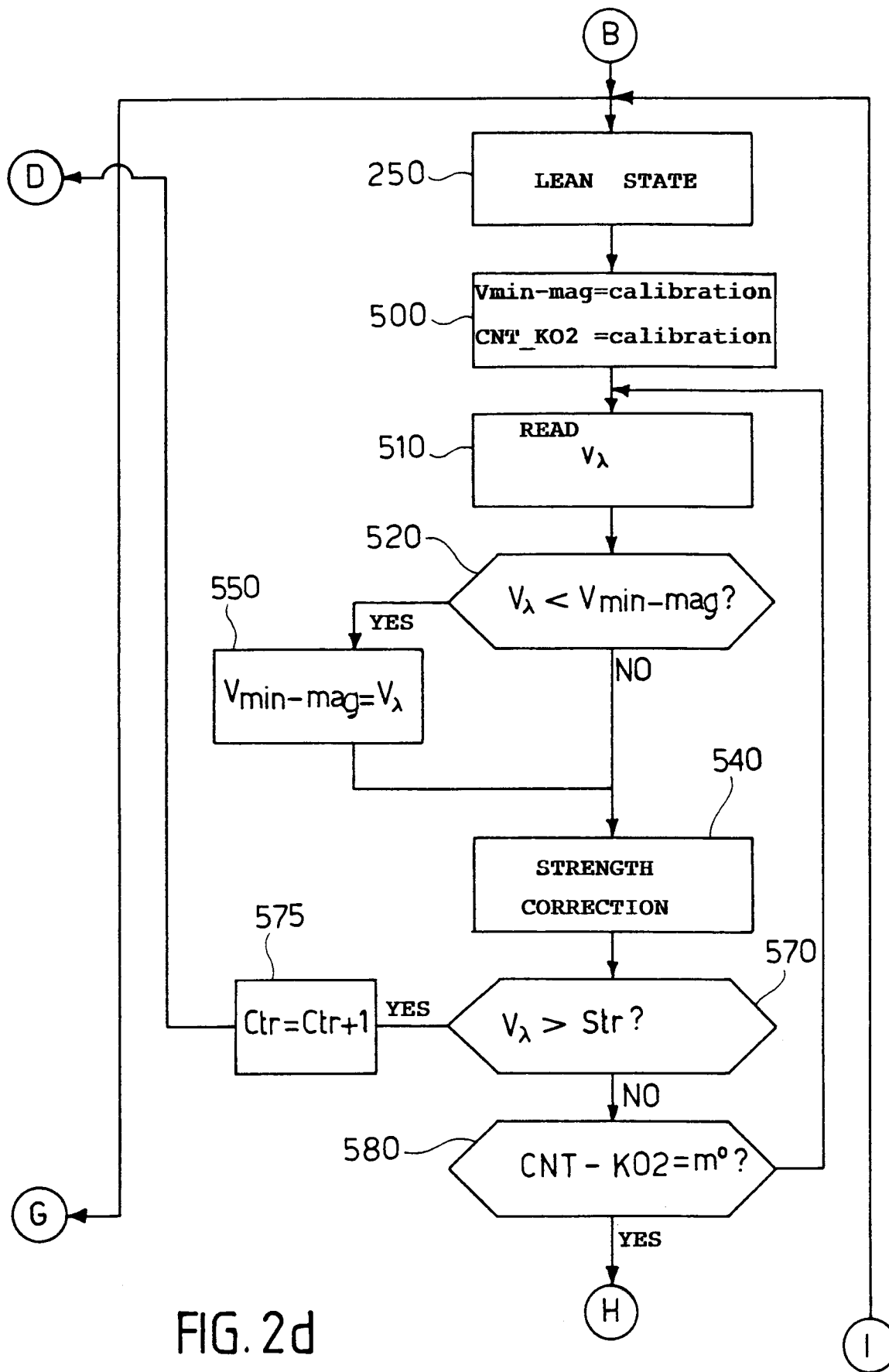

FIG. 2d

FIG. 2e

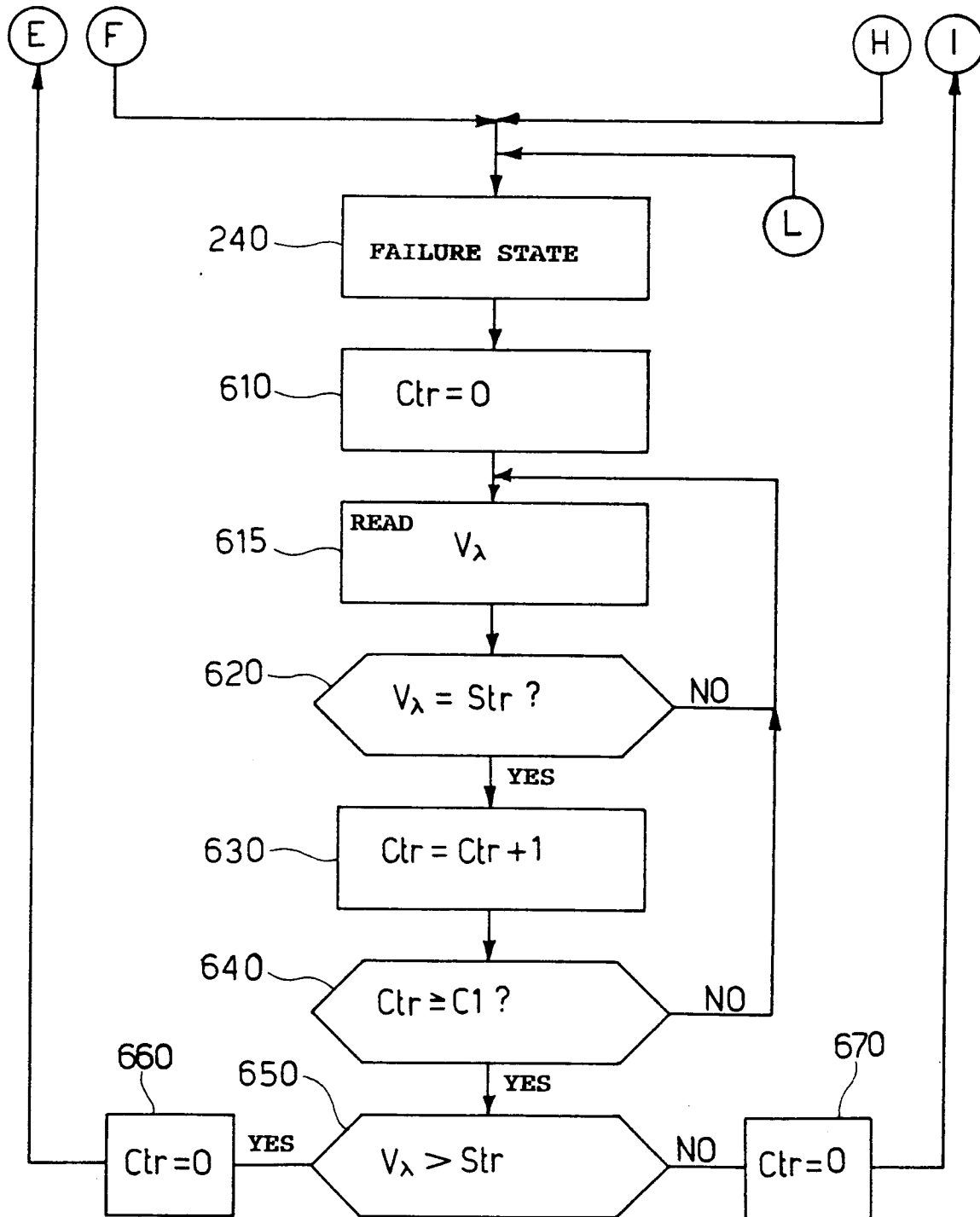

FIG. 3

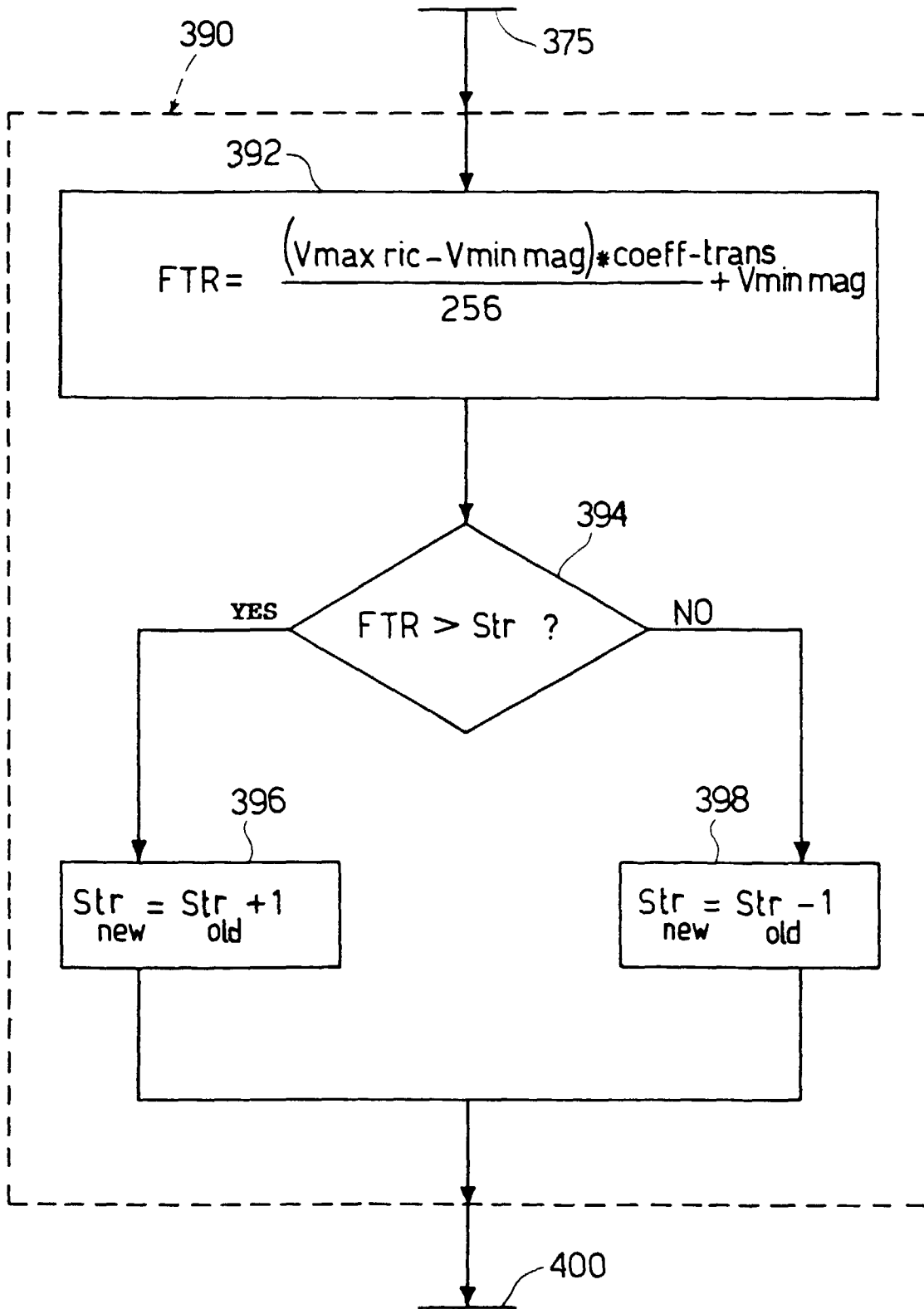

FIG. 4a

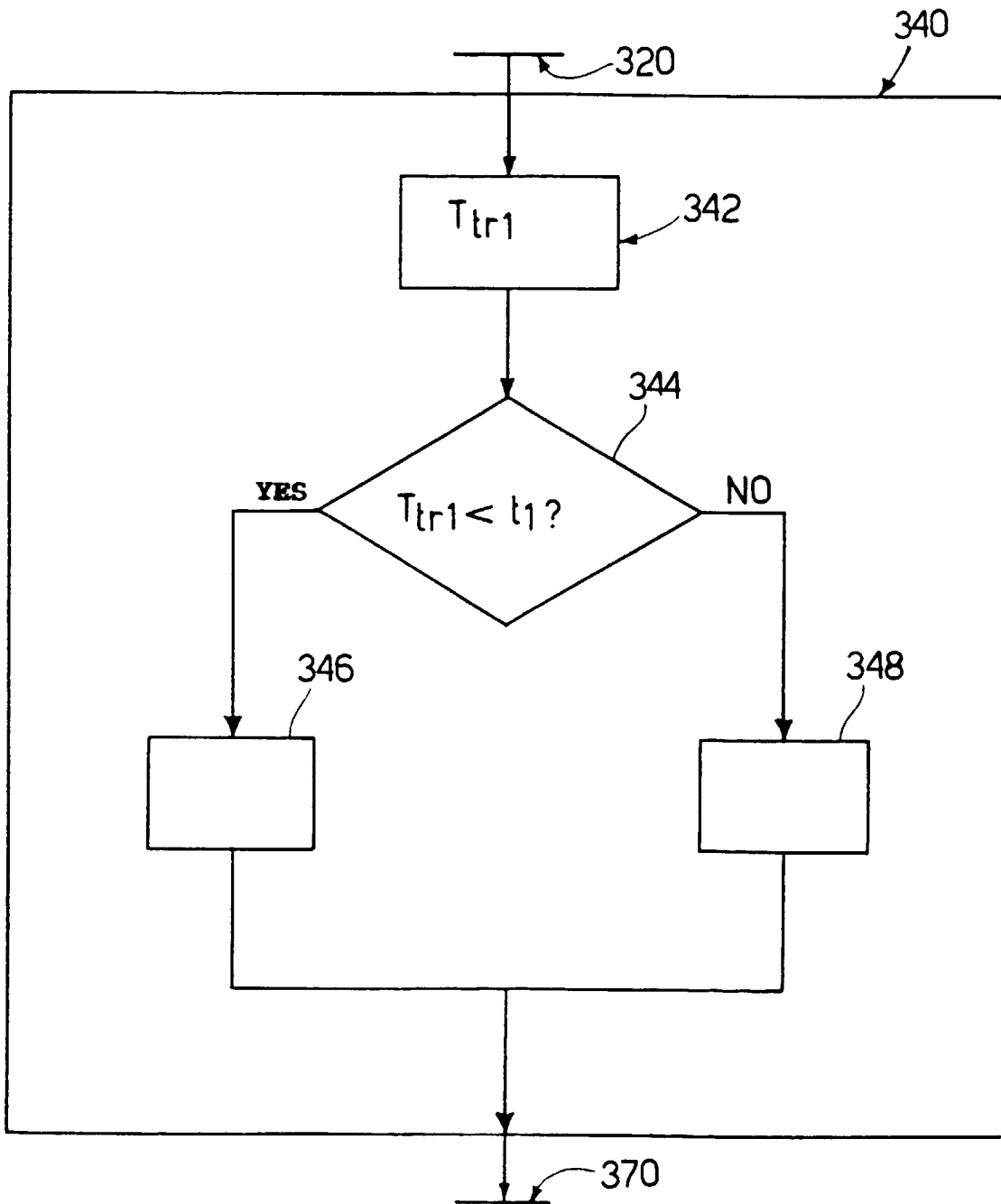

FIG. 4b

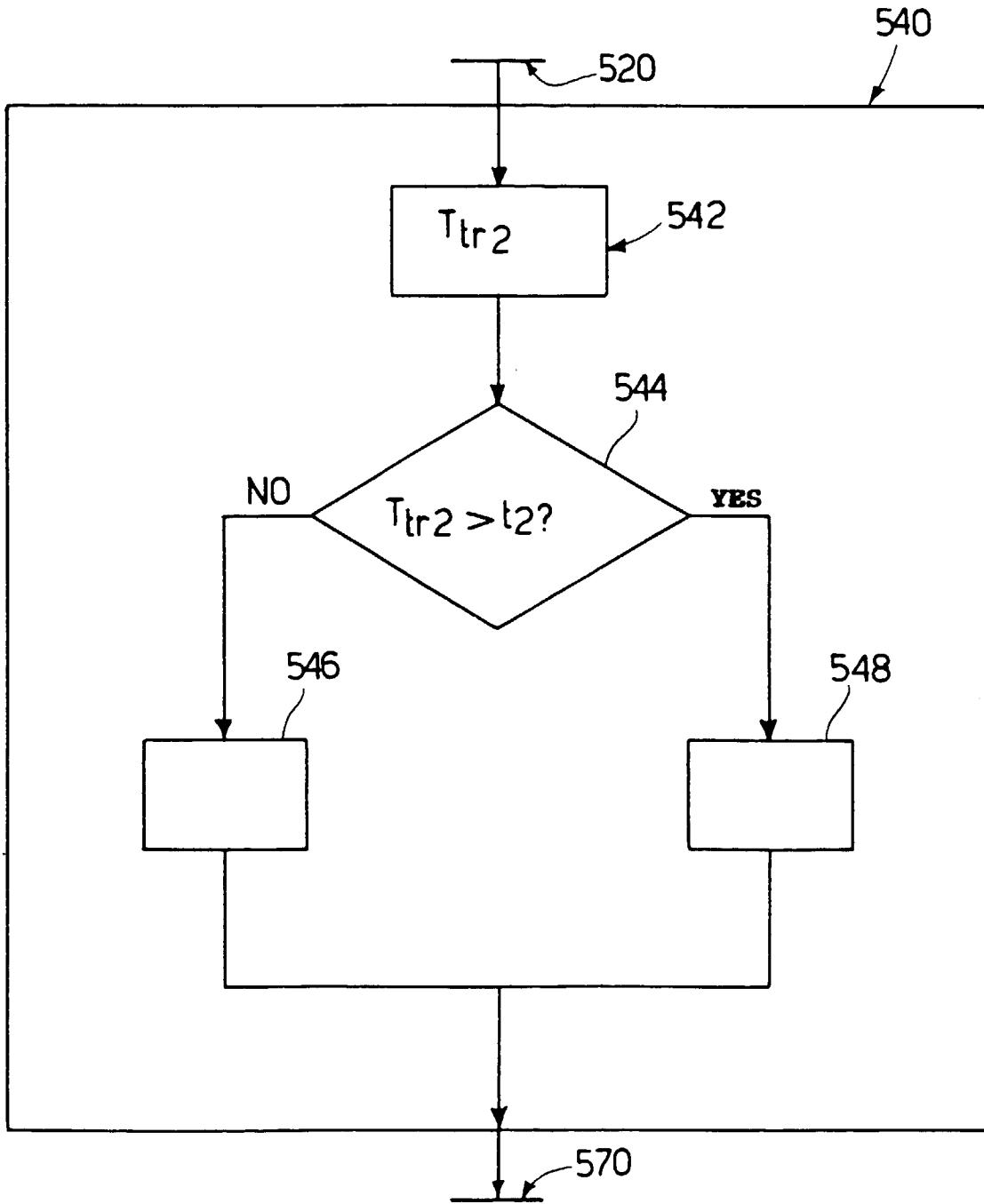

FIG. 5

