

(19) World Intellectual Property Organization  
International Bureau



(43) International Publication Date  
30 October 2008 (30.10.2008)

PCT

(10) International Publication Number  
WO 2008/131223 A1

- (51) International Patent Classification:  
F02G 1/043 (2006.01)
- (21) International Application Number:  
PCT/US2008/060827
- (22) International Filing Date: 18 April 2008 (18.04.2008)
- (25) Filing Language: English
- (26) Publication Language: English
- (30) Priority Data:  
60/925,814 23 April 2007 (23.04.2007) US  
60/925,818 23 April 2007 (23.04.2007) US
- (71) Applicant (for all designated States except US): NEW  
POWER CONCEPTS, LLC [US/US]; 340 Commercial  
Street, Manchester, NH 03101-1108 (US).
- (72) Inventors; and
- (75) Inventors/Applicants (for US only): KAMEN, Dean  
[US/US]; 15 Westwind Drive, Bedford, NH 03110 (US).  
LANGENFELD, Christopher, C. [US/US]; 35 Cathed-  
ral Circle, Nashua, NH 03063 (US). BHAT, Prashant

[IN/US]; 197 Streamside Drive, Manchester, NH 03102  
(US). SMITH, Stanley, B. [US/US]; 78 Main Street,  
Raymond, NH 03077 (US).

(74) Agent: TEMPLE, Michelle, Saquet; DEKA Research &  
Development Corp., 340 Commercial Street, Manchester,  
NH 03101 (US).

(81) Designated States (unless otherwise indicated, for every  
kind of national protection available): AE, AG, AL, AM,  
AO, AT, AU, AZ, BA, BB, BG, BH, BR, BW, BY, BZ, CA,  
CH, CN, CO, CR, CU, CZ, DE, DK, DM, DO, DZ, EC, EE,  
EG, ES, FI, GB, GD, GE, GH, GM, GT, HN, HR, HU, ID,  
IL, IN, IS, JP, KE, KG, KM, KN, KP, KR, KZ, LA, LC,  
LK, LR, LS, LT, LU, LY, MA, MD, ME, MG, MK, MN,  
MW, MX, MY, MZ, NA, NG, NI, NO, NZ, OM, PG, PH,  
PL, PT, RO, RS, RU, SC, SD, SE, SG, SK, SL, SM, SV,  
SY, TJ, TM, TN, TR, TT, TZ, UA, UG, US, UZ, VC, VN,  
ZA, ZM, ZW.

(84) Designated States (unless otherwise indicated, for every  
kind of regional protection available): ARIPO (BW, GH,  
GM, KE, LS, MW, MZ, NA, SD, SL, SZ, TZ, UG, ZM,

[Continued on next page]

(54) Title: STIRLING CYCLE MACHINE

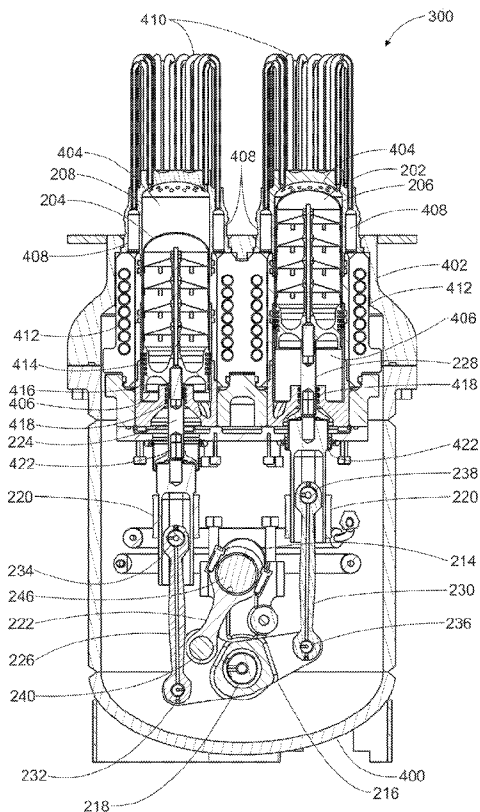

FIG. 4

(57) Abstract: A Stirling cycle machine. The machine in-  
cludes at least one rocking drive mechanism which includes:  
a rocking beam having a rocker pivot, at least one cylinder  
and at least one piston. The piston is housed within a respec-  
tive cylinder and is capable of substantially linearly reciprocating  
within the respective cylinder. Also, the drive mechanism  
includes at least one coupling assembly having a proximal  
end and a distal end. The proximal end is connected to the  
piston and the distal end is connected to the rocking  
beam by an end pivot. The linear motion of the piston is converted  
to rotary motion of the rocking beam. Also, a crankcase  
housing the rocking beam and housing a first portion of the  
coupling assembly is included. A crankshaft coupled to the  
rocking beam by way of a connecting rod is also included.  
The rotary motion of the rocking beam is transferred to the  
crankshaft. The machine also includes a working space housing  
the at least one cylinder, the at least one piston and a second  
portion of the coupling assembly. A seal is included for  
sealing the workspace from the crankcase.

WO 2008/131223 A1



ZW), Eurasian (AM, AZ, BY, KG, KZ, MD, RU, TJ, TM),  
European (AT, BE, BG, CH, CY, CZ, DE, DK, EE, ES, FI,  
FR, GB, GR, HR, HU, IE, IS, IT, LT, LU, LV, MC, MT, NL,  
NO, PL, PT, RO, SE, SI, SK, TR), OAPI (BF, BJ, CF, CG,  
CI, CM, GA, GN, GQ, GW, ML, MR, NE, SN, TD, TG).

**Published:**

- *with international search report*
- *before the expiration of the time limit for amending the claims and to be republished in the event of receipt of amendments*

**Declaration under Rule 4.17:**

- *of inventorship (Rule 4.17(iv))*

## STIRLING CYCLE MACHINE

### CROSS REFERENCE TO RELATED APPLICATIONS

The present application claims priority from Provisional Patent Application No.  
5 60/925,818, filed April 23, 2007 and entitled Four Cylinder Stirling Engine; and Provisional  
Patent Application No. 60/925,814, filed April 23, 2007 and entitled Rocking Beam Drive,  
both of which are incorporated herein by reference.

### TECHNICAL FIELD

10 The present invention relates to machines and more particularly, to a Stirling cycle  
machine and components thereof.

### BACKGROUND INFORMATION

Many machines, such as internal combustion engines, external combustion engines,  
15 compressors, and other reciprocating machines, employ an arrangement of pistons and drive  
mechanisms to convert the linear motion of a reciprocating piston to rotary motion. In most  
applications, the pistons are housed in a cylinder. A common problem encountered with  
such machines is that of friction generated by a sliding piston resulting from misalignment  
of the piston in the cylinder and lateral forces exerted on the piston by linkage of the piston  
20 to a rotating crankshaft. These increased side loads increase engine noise, increase piston  
wear, and decrease the efficiency and life of the engine. Additionally, because of the side  
loads, the drive requires more power to overcome these frictional forces, thus reducing the  
efficiency of the machine.

Improvements have been made on drive mechanisms in an attempt to reduce these  
25 side loads, however, many of the improvements have resulted in heavier and bulkier  
machines.

Accordingly, there is a need for practical machines with minimal side loads on  
pistons.

### SUMMARY

30 In accordance with one aspect of the present invention, a rocking beam drive  
mechanism for a machine is disclosed. The drive mechanism includes a rocking beam  
having a rocker pivot, at least one cylinder and at least one piston. The piston is housed  
within a respective cylinder. The piston is capable of substantially linearly reciprocating  
within the respective cylinder. Also, the drive mechanism includes at least one coupling

assembly having a proximal end and a distal end. The proximal end is connected to the piston and the distal end is connected to the rocking beam by an end pivot. The linear motion of the piston is converted to rotary motion of the rocking beam.

Some embodiments of this aspect of the present invention include one or more of the following: where the rocking beam is coupled to a crankshaft by way of a connecting rod. In this embodiment, the rotary motion of the rocking beam is transferred to the crankshaft. Also, where the cylinder may further include a closed end and an open end. The open end further includes a linear bearing connected to the cylinder. The linear bearing includes an opening to accommodate the coupling assembly. Also, where the coupling assembly further includes a piston rod and a link rod. The piston rod and link rod are coupled together by a coupling means. The coupling means is located beneath the linear bearing. Also, where the drive mechanism also includes a seal, where the seal is sealably connected to the piston rod. Also, where the seal is a rolling diaphragm. Also, in some embodiments, the coupling means is a flexible joint. In some embodiments, the coupling means is a roller bearing. In some embodiments, the coupling means is a hinge. In some embodiments, the coupling means is a flexure. In some embodiments, the coupling means is a journal bearing joint.

In accordance with another aspect of the present invention, a Stirling cycle machine is disclosed. The machine includes at least one rocking drive mechanism where the rocking drive mechanism includes: a rocking beam having a rocker pivot, at least one cylinder and at least one piston. The piston is housed within a respective cylinder. The piston is capable of substantially linearly reciprocating within the respective cylinder. Also, the drive mechanism includes at least one coupling assembly having a proximal end and a distal end. The proximal end is connected to the piston and the distal end is connected to the rocking beam by an end pivot. The linear motion of the piston is converted to rotary motion of the rocking beam. Also, a crankcase housing the rocking beam and housing a first portion of the coupling assembly is included. A crankshaft coupled to the rocking beam by way of a connecting rod is also included. The rotary motion of the rocking beam is transferred to the crankshaft. The machine also includes a working space housing the at least one cylinder, the at least one piston and a second portion of the coupling assembly. A seal is included for sealing the workspace from the crankcase.

Some embodiments of this aspect of the present invention include one or more of the following: where the seal is a rolling diaphragm. Also, the cylinder may further include a closed end and an open end. The open end further includes a linear bearing connected to the cylinder. The linear bearing includes an opening to accommodate the coupling

assembly. Also, where the coupling assembly further includes a piston rod and a link rod. The piston rod and link rod are coupled together by a coupling means. The coupling means may be located beneath the linear bearing. Also, the machine may also include a lubricating fluid pump in the crankcase. In some embodiments, the lubricating fluid pump is a  
5 mechanical lubricating fluid pump driven by a pump drive assembly, the pump drive assembly being connected to and driven by the crankshaft. In some embodiments, the lubricating fluid pump is an electric lubricating fluid pump. The machine may also include a motor connected to the crankshaft. The machine may also include a generator connected to the crankshaft.

10 In accordance with another aspect of the present invention, a Stirling cycle machine is disclosed. The machine includes at least two rocking drive mechanisms. The rocking drive mechanisms each include a rocking beam having a rocker pivot, two cylinders, and two pistons. The pistons each housed within a respective cylinder. The pistons are capable of substantially linearly reciprocating within the respective cylinder. Also, the drive  
15 mechanisms include two coupling assemblies having a proximal end and a distal end, the proximal end being connected to the piston and the distal end being connected to the rocking beam by an end pivot. The linear motion of the piston is converted to rotary motion of the rocking beam. The machine also includes a crankcase housing the rocking beam and housing a first portion of the coupling assemblies. Also, a crankshaft coupled to the rocking  
20 beam by way of a connecting rod. The rotary motion of the rocking beam is transferred to the crankshaft. The machine also includes a lubricating fluid pump in the crankcase for pumping lubricating fluid to lubricate the crankshaft and the rocking beam and the first portion of the coupling assemblies. Also, a working space housing the cylinders, the pistons and the second portion of the coupling assemblies. A rolling diaphragm for sealing  
25 the workspace from the crankcase is also included.

Some embodiments of this aspect of the present invention include one or more of the following: where the cylinder may further include a closed end and an open end. The open end further includes a linear bearing connected to the cylinder. The linear bearing includes an opening to accommodate the coupling assembly. Also, where the coupling assembly  
30 further includes a piston rod and a link rod. The piston rod and link rod are coupled together by a coupling means. The coupling means may be located beneath the linear bearing. Also, where the coupling means is a flexible joint. In some embodiments, also disclosed is where the coupling means is a roller bearing.

These aspects of the invention are not meant to be exclusive and other features, aspects, and advantages of the present invention will be readily apparent to those of ordinary skill in the art when read in conjunction with the appended claims and accompanying drawings.

5

#### BRIEF DESCRIPTION OF THE DRAWINGS

These and other features and advantages of the present invention will be better understood by reading the following detailed description, taken together with the drawings wherein:

- FIGS. 1A-1E depict the principle of operation of a prior art Stirling cycle machine;
- 10 FIG. 2 shows a view of a rocking beam drive in accordance with one embodiment;
- FIG. 3 shows a view of a rocking beam drive in accordance with one embodiment;
- FIG. 4 shows a view of an engine in accordance with one embodiment;
- FIGS. 5A-5D depicts various views of a rocking beam drive in accordance with one embodiment;
- 15 FIG. 6 shows a bearing style rod connector in accordance with one embodiment;
- FIGS. 7A-7B show a flexure in accordance with one embodiment;
- FIG. 8 shows a four cylinder double rocking beam drive arrangement in accordance with one embodiment;
- FIG. 9 shows a cross section of a crankshaft in accordance with one embodiment;
- 20 FIG. 10A shows a view of an engine in accordance with one embodiment;
- FIG. 10B shows a crankshaft coupling in accordance with one embodiment;
- FIG. 10C shows a view of a sleeve rotor in accordance with one embodiment;
- FIG. 10D shows a view of a crankshaft in accordance with one embodiment;
- FIG. 10E is a cross section of the sleeve rotor and spline shaft in accordance with
- 25 one embodiment;
- FIG. 10F is a cross section of the crankshaft and the spline shaft in accordance with one embodiment;
- FIG. 10G are various views a sleeve rotor, crankshaft and spline shaft in accordance with one embodiment;
- 30 FIG. 11 shows the operation of pistons of an engine in accordance with one embodiment;
- FIG. 12A shows an unwrapped schematic view of a working space and cylinders in accordance with one embodiment;

FIG. 12B shows a schematic view of a cylinder, heater head, and regenerator in accordance with one embodiment;

FIG. 12C shows a view of a cylinder head in accordance with one embodiment;

FIG. 13A shows a view of a rolling diaphragm, along with supporting top seal piston  
5 and bottom seal piston, in accordance with one embodiment;

FIG. 13B shows an exploded view of a rocking beam driven engine in accordance with one embodiment;

FIG. 13C shows a view of a cylinder, heater head, regenerator, and rolling diaphragm, in accordance with one embodiment;

10 FIGS. 13D-13E show various views of a rolling diaphragm during operation, in accordance with one embodiment;

FIG. 13F shows an unwrapped schematic view of a working space and cylinders in accordance with one embodiment;

FIG. 13G shows a view of an external combustion engine in accordance with one;

15 FIGS. 14A-14E show views of various embodiments of a rolling diaphragm;

FIG. 15A shows a view of a metal bellows and accompanying piston rod and pistons in accordance with one embodiment;

FIGS. 15B-15D show views of metal bellows diaphragms, in accordance with one embodiment;

20 FIGS. 15E-15G show a view of metal bellows in accordance with various embodiments;

FIG. 15H shows a schematic of a rolling diaphragm identifying various load regions;

25 FIG. 15I shows a schematic of the rolling diaphragm identifying the convolution region;

FIG. 16 shows a view of a piston and piston seal in accordance with one embodiment;

FIG. 17 shows a view of a piston rod and piston rod seal in accordance with one embodiment;

30 FIG. 18A shows a view of a piston seal backing ring in accordance with one embodiment;

FIG. 18B shows a pressure diagram for a backing ring in accordance with one embodiment;

FIGS. 18C and 18D show a piston seal in accordance with one embodiment;

FIGS. 18E and 18F show a piston rod seal in accordance with one embodiment;

FIG. 19A shows a view of a piston seal backing ring in accordance with one embodiment;

FIG. 19B shows a pressure diagram for a piston seal backing ring in accordance with one embodiment;

FIG. 20A shows a view of a piston rod seal backing ring in accordance with one embodiment;

FIG. 20B shows a pressure diagram for a piston rod seal backing ring in accordance with one embodiment;

FIG. 21 shows views of a piston guide ring in accordance with one embodiment;

FIG. 22 shows an unwrapped schematic illustration of a working space and cylinders in accordance with one embodiment;

FIG. 23A shows a view of an engine in accordance with one embodiment;

FIG. 23B shows a view of an engine in accordance with one embodiment;

FIG. 24 shows a view of a crankshaft in accordance with one embodiment;

FIGS. 25A-25C show various configurations of pump drives in accordance with various embodiments;

FIGS. 26A show various views of an oil pump in accordance with one embodiment;

FIG. 26B shows a view of an engine in accordance with one embodiment;

FIG. 26C shows another view of the engine depicted in FIG. 26B;

FIGS. 27A and 27B show views of an engine in accordance with one embodiment;

FIG. 27C shows a view of a coupling joint in accordance with one embodiment;

FIG. 27D shows a view of a crankshaft and spline shaft of an engine in accordance with one embodiment;

FIG. 28 shows a view of a heater exchanger and burner for an engine in accordance with one embodiment;

FIG. 29 shows a view of a tube heat exchanger in accordance with one embodiment;

FIG. 30 shows a view of a tube heat exchanger in accordance with one embodiment;

FIG. 31 shows a view of a tube heat exchanger in accordance with one embodiment;

FIG. 32 shows a view of heater tubes of a heat exchanger in accordance with one embodiment;

FIG. 33 shows a view of heater tubes of a heat exchanger in accordance with one embodiment;

FIG. 34 shows a view of a tube heat exchanger in accordance with one embodiment;

FIG. 35 shows a view of a tube heat exchanger in accordance with one embodiment;

FIG. 36 shows a view of a heater head of an engine in accordance with one embodiment;

FIG. 37 shows a view of a tube heat exchanger in accordance with one embodiment;

5 FIG. 38 shows a view of a tube heat exchanger in accordance with one embodiment;

FIG. 39 shows a portion of a cross section of a tube heat exchanger in accordance with one embodiment;

FIG. 40 shows a view of a tube heat exchanger in accordance with one embodiment;

10 FIG. 41 shows a portion of a cross section of a tube heat exchanger in accordance with one embodiment;

FIG. 42 shows a view of a heater head of an engine in accordance with one embodiment;

FIG. 43A shows a view of a tube heat exchanger in accordance with one embodiment;

15 FIG. 43B shows a view of a tube heat exchanger in accordance with one embodiment;

FIG. 44A shows a view of a tube heat exchanger in accordance with one embodiment;

20 FIG. 44B shows a view of a tube heat exchanger in accordance with one embodiment;

FIG. 45A shows view of a tube heat exchanger in accordance with one embodiment;

FIG. 45B shows a view of a tube heat exchanger in accordance with one embodiment;

25 FIGS. 46A-46D show various configurations of a tube heat exchanger in accordance with various embodiments;

FIG. 47 shows a view of a tube heat exchanger in accordance with one embodiment;

FIG. 48 shows a view of a tube heat exchanger in accordance with one embodiment;

FIG. 49 shows a view of a heater head of an engine in accordance with one embodiment;

30 FIG. 50 shows a view of a tube heat exchanger in accordance with one embodiment;

FIGS. 51A and 51B show views of heat exchangers of an engine in accordance with various embodiments;

FIGS. 52A-52C show various views of a heat exchanger in accordance with one embodiment;

FIG. 52D shows a view of a heat exchanger in accordance with one embodiment;  
FIGS. 53A and 53B show views of a heat exchanger in accordance with one  
embodiment;

FIG. 53C shows a view of a heat exchanger of an engine in accordance with one  
5 embodiment;

FIGS. 53D-53F show views of a heat exchanger of an engine in accordance with one  
embodiment;

FIGS. 54A and 54B show views of a heat exchanger of an engine in accordance with  
one embodiment;

10 FIGS. 55A-55D show various views of a heat exchanger in accordance with one  
embodiment;

FIGS. 56A-56C show various configurations of a heat exchanger in accordance with  
various embodiments;

15 FIGS. 57A and 57B show various diagrams depicting physical properties of a heat  
exchanger in accordance with one embodiment;

FIG. 58 shows a view of a heater head in accordance with one embodiment;

FIG. 59 shows a view of a heater head in accordance with one embodiment;

FIGS. 60A and 60B show views of a heater head in accordance with one  
embodiment;

20 FIGS. 61A and 61B show views of a heater head in accordance with one  
embodiment;

FIGS. 62A and 62B show views of a heater head in accordance with one  
embodiment;

FIG. 62C shows a views of a heater head in accordance with one embodiment;

25 FIG. 62D shows a view of a heater head in accordance with one embodiment;

FIG. 62E shows a view of a heater head in accordance with one embodiment;

FIGS. 63A and 63B show a regenerator of a Stirling cycle engine in accordance with  
one embodiment;

30 FIGS. 64A-64E show various configurations of a regenerator of a Stirling cycle  
engine in accordance with various embodiments;

FIGS. 65A-65G show various views of an engine in accordance with several  
embodiments;

FIGS. 66A and 66B show views of a cooler for an engine in accordance with some  
embodiments;

FIG. 67A shows a view of a cooler for an engine in accordance with one embodiment;

FIG. 67B shows a view of a cooler for an engine in accordance with one embodiment;

5 FIG. 67C shows a view of the embodiment of a cooler for an engine depicted in FIG. 67A;

FIG. 68 shows a view of an intake manifold for an engine in accordance with one embodiment;

10 FIGS. 69A and 69B show various views of an intake manifold for an engine in accordance with one embodiment;

FIG. 70 shows a view of a heater head of an engine in accordance with yet another embodiment of the invention;

FIG. 71A and 71B show views of a burner of an engine in accordance with one embodiment;

15 FIG. 72 is a gaseous fuel burner coupled to a Stirling cycle engine, where the ejector is a venturi, according to one embodiment;

FIG. 73A is the burner of FIG. 72 showing the air and fuel flow paths;

FIG. 73B is a graphical representation of the pressure across the burner;

FIG. 74 shows a view of a venturi as shown in the burner of FIG. 72;

20 FIGS. 75 and 75A are embodiments of the venturi in FIG. 72;

FIG. 75B shows a schematic of a multiple fuel system with multiple fuel restrictions and valves;

FIG. 76 shows a schematic of an embodiment of the burner with automated fuel control for variable fuel properties;

25 FIG. 77 shows a schematic of another embodiment of the burner with temperature sensor and engine speed control loop;

FIG. 78 shows a schematic of yet another embodiment of the burner with temperature sensor and oxygen sensor control loop;

30 FIG. 79 shows an alternative embodiment of the ejector wherein the fuel is fed directly into the ejector;

FIG. 80 is a block diagram showing a system for controlling a pressurized combustion chamber of an engine according to an embodiment;

FIG. 81 shows a piston pump according to one embodiment;

FIG. 82 shows an alternating current waveform suitable for driving the piston pump of FIG. 81;

FIG. 83 shows a pulse-width-modulated direct current waveform suitable for driving the piston pump of FIG. 81, according to one embodiment;

5 FIG. 84 is schematic diagram of a diaphragm pump according to one embodiment;

FIG. 85 is a schematic diagram of a center-tapped coil for a diaphragm pump according to one embodiment;

FIGS. 86A and 86B shows pulse-width-modulated direct current waveforms suitable for driving the center-tapped coil of FIG. 85, according to some embodiments;

10 FIGS. 87A-87D show embodiments of including a filter between the fuel pump and combustion chamber;

FIG. 88 shows a view of an engine in accordance with one embodiment;

FIGS. 89A -- 89C show views of a burner for an engine in accordance with various embodiments;

15 FIG. 90 shows a view of an engine with multiple burners in accordance with yet another embodiment of the invention;

FIGS. 91A and 91B show views of multiple burners for an engine in accordance with various embodiments;

FIG. 91C shows a view of a tube heater head in accordance with one embodiment;

20 and

FIG. 91D shows a cross section of the tube heater head depicted in FIG. 91C.

#### DETAILED DESCRIPTION OF THE PREFERRED EMBODIMENTS

25 Stirling cycle machines, including engines and refrigerators, have a long technological heritage, described in detail in Walker, Stirling Engines, Oxford University Press (1980), incorporated herein by reference. The principle underlying the Stirling cycle engine is the mechanical realization of the Stirling thermodynamic cycle: isovolumetric heating of a gas within a cylinder, isothermal expansion of the gas (during which work is performed by driving a piston), isovolumetric cooling, and isothermal compression.

30 Additional background regarding aspects of Stirling cycle machines and improvements thereto is discussed in Hargreaves, The Phillips Stirling Engine (Elsevier, Amsterdam, 1991), which is herein incorporated by reference.

The principle of operation of a Stirling cycle machine is readily described with reference to FIGS. 1A-1E, wherein identical numerals are used to identify the same or

similar parts. Many mechanical layouts of Stirling cycle machines are known in the art, and the particular Stirling cycle machine designated generally by numeral **10** is shown merely for illustrative purposes. In FIGS. 1A to 1D, piston **12** and a displacer **14** move in phased reciprocating motion within the cylinders **16** which, in some embodiments of the Stirling cycle machine, may be a single cylinder, but in other embodiments, may include greater than a single cylinder. A working fluid contained within cylinders **16** is constrained by seals from escaping around piston **12** and displacer **14**. The working fluid is chosen for its thermodynamic properties, as discussed in the description below, and is typically helium at a pressure of several atmospheres, however, any gas, including any inert gas, may be used, including, but not limited to, hydrogen, argon, neon, nitrogen, air and any mixtures thereof. The position of the displacer **14** governs whether the working fluid is in contact with the hot interface **18** or the cold interface **20**, corresponding, respectively, to the interfaces at which heat is supplied to and extracted from the working fluid. The supply and extraction of heat is discussed in further detail below. The volume of working fluid governed by the position of the piston **12** is referred to as the compression space **22**.

During the first phase of the Stirling cycle, the starting condition of which is depicted in FIG. 1A, the piston **12** compresses the fluid in the compression space **22**. The compression occurs at a substantially constant temperature because heat is extracted from the fluid to the ambient environment. The condition of the Stirling cycle machine **10** after compression is depicted in FIG. 1B. During the second phase of the cycle, the displacer **14** moves in the direction of the cold interface **20**, with the working fluid displaced from the region of the cold interface **20** to the region of the hot interface **18**. This phase may be referred to as the transfer phase. At the end of the transfer phase, the fluid is at a higher pressure since the working fluid has been heated at constant volume. The increased pressure is depicted symbolically in FIG. 1C by the reading of the pressure gauge **24**.

During the third phase (the expansion stroke) of the Stirling cycle machine, the volume of the compression space **22** increases as heat is drawn in from outside the Stirling cycle machine **10**, thereby converting heat to work. In practice, heat is provided to the fluid by means of a heater head (not shown) which is discussed in greater detail in the description below. At the end of the expansion phase, the compression space **22** is full of cold fluid, as depicted in FIG. 1D. During the fourth phase of the Stirling cycle machine **10**, fluid is transferred from the region of the hot interface **18** to the region of the cold interface **20** by motion of the displacer **14** in the opposing sense. At the end of this second transfer phase, the fluid fills the compression space **22** and cold interface **20**, as depicted in FIG. 1A, and is

ready for a repetition of the compression phase. The Stirling cycle is depicted in a P-V (pressure-volume) diagram as shown in FIG. 1E.

Additionally, on passing from the region of the hot interface **18** to the region of the cold interface **20**. In some embodiments, the fluid may pass through a regenerator (shown as **408** in FIG. 4). A regenerator is a matrix of material having a large ratio of surface area to volume which serves to absorb heat from the fluid when it enters from the region of the hot interface **18** and to heat the fluid when it passes from the region of the cold interface **20**.

Stirling cycle machines have not generally been used in practical applications due to several daunting challenges to their development. These involve practical considerations such as efficiency and lifetime. Accordingly, there is a need for more Stirling cycle machines with minimal side loads on pistons, increased efficiency and lifetime.

The principle of operation of a Stirling cycle machine or Stirling engine is further discussed in detail in U.S. Patent No. 6,381,958, issued May 7, 2002, to *Kamen et al.*, which is herein incorporated by reference in its entirety.

15

#### **Rocking Beam Drive**

Referring now to FIGS. 2-4, embodiments of a Stirling cycle machine, according to one embodiment, are shown in cross-section. The engine embodiment is designated generally by numeral **300**. While the Stirling cycle machine will be described generally with reference to the Stirling engine **300** embodiments shown in FIGS. 2-4, it is to be understood that many types of machines and engines, including but not limited to refrigerators and compressors may similarly benefit from various embodiments and improvements which are described herein, including but not limited to, external combustion engines and internal combustion engines.

FIG. 2 depicts a cross-section of an embodiment of a rocking beam drive mechanism **200** (the term "rocking beam drive" is used synonymously with the term "rocking beam drive mechanism") for an engine, such as a Stirling engine, having linearly reciprocating pistons **202** and **204** housed within cylinders **206** and **208**, respectively. The cylinders include linear bearings **220**. Rocking beam drive **200** converts linear motions of pistons **202** and **204** into the rotary motion of a crankshaft **214**. Rocking beam drive **200** has a rocking beam **216**, rocker pivot **218**, a first coupling assembly **210**, and a second coupling assembly **212**. Pistons **202** and **204** are coupled to rocking beam drive **200**, respectively, via first coupling assembly **210** and second coupling assembly **212**. The rocking beam drive is coupled to crankshaft **214** via a connecting rod **222**.

In some embodiments, the rocking beam and a first portion of the coupling assembly may be located in a crankcase, while the cylinders, pistons and a second portion of the coupling assembly is located in a workspace.

In FIG. 4 a crankcase **400** most of the rocking beam drive **200** is positioned below  
5 the cylinder housing **402**. Crankcase **400** is a space to permit operation of rocking beam drive **200** having a crankshaft **214**, rocking beam **216**, linear bearings **220**, a connecting rod **222**, and coupling assemblies **210** and **212**. Crankcase **400** intersects cylinders **206** and **208** transverse to the plane of the axes of pistons **202** and **204**. Pistons **202** and **204** reciprocate in respective cylinders **206** and **208**, as also shown in FIG 2. Cylinders **206** and **208** extend  
10 above crankshaft housing **400**. Crankshaft **214** is mounted in crankcase **400** below cylinders **206** and **208**.

FIG. 2 shows one embodiment of rocking beam drive **200**. Coupling assemblies **210** and **212** extend from pistons **202** and **204**, respectively, to connect pistons **202** and **204** to rocking beam **216**. Coupling assembly **212** for piston **204**, in some embodiments, may  
15 comprise a piston rod **224** and a link rod **226**. Coupling assembly **210** for piston **202**, in some embodiments, may comprise a piston rod **228** and a link rod **230**. Piston **204** operates in the cylinder **208** vertically and is connected by the coupling assembly **212** to the end pivot **232** of the rocking beam **216**. The cylinder **208** provides guidance for the longitudinal motion of piston **204**. The piston rod **224** of the coupling assembly **212** attached to the  
20 lower portion of piston **204** is driven axially by its link rod **226** in a substantially linear reciprocating path along the axis of the cylinder **208**. The distal end of piston rod **224** and the proximate end of link rod **226**, in some embodiments, may be jointly hinged via a coupling means **234**. The coupling means **234**, may be any coupling means known in the art, including but not limited to, a flexible joint, roller bearing element, hinge, journal  
25 bearing joint (shown as **600** in FIG. 6), and flexure (shown as **700** in FIGS. 7A and 7B). The distal end of the link rod **226** may be coupled to one end pivot **232** of rocking beam **216**, which is positioned vertically and perpendicularly under the proximate end of the link rod **226**. A stationary linear bearing **220** may be positioned along coupling assembly **212** to further ensure substantially linear longitudinal motion of the piston rod **224** and thus  
30 ensuring substantially linear longitudinal motion of the piston **204**. In an exemplary embodiment, link rod **226** does not pass through linear bearing **220**. This ensures, among other things, that piston rod **224** retains a substantially linear and longitudinal motion.

[0001] In the exemplary embodiment, the link rods may be made from aluminum, and the piston rods and connecting rod are made from D2 Tool Steel. Alternatively, the link rods,

piston rods, connecting rods, and rocking beam may be made from 4340 steel. Other materials may be used for the components of the rocking beam drive, including, but not limited to, titanium, aluminum, steel or cast iron. In some embodiments, the fatigue strength of the material being used is above the actual load experienced by the components during operation.

Still referring to FIGS. 2-4, piston **202** operates vertically in the cylinder **206** and is connected by the coupling assembly **210** to the end pivot **236** of the rocking beam **216**. The cylinder **206** serves, amongst other functions, to provide guidance for longitudinal motion of piston **202**. The piston rod **228** of the coupling assembly **210** is attached to the lower portion of piston **202** and is driven axially by its link rod **230** in a substantially linear reciprocating path along the axis of the cylinder **206**. The distal end of the piston rod **228** and the proximate end of the link rod **230**, in some embodiments, is jointly hinged via a coupling means **238**. The coupling means **238**, in various embodiments may include, but are not limited to, a flexure (shown as **700** in FIGS. 7A and 7B, roller bearing element, hinge, journal bearing (shown as **600** in FIG. 6), or coupling means as known in the art. The distal end of the link rod **230**, in some embodiments, may be coupled to one end pivot **236** of rocking beam **216**, which is positioned vertically and perpendicularly under the proximate end of link rod **230**. A stationary linear bearing **220** may be positioned along coupling assembly **210** to further ensure linear longitudinal motion of the piston rod **228** and thus ensuring linear longitudinal motion of the piston **202**. In an exemplary embodiment, link rod **230** does not pass through linear bearing **220** to ensure that piston rod **228** retains a substantially linear and longitudinal motion.

[0002] The coupling assemblies **210** and **212** change the alternating longitudinal motion of respective pistons **202** and **204** to oscillatory motion of the rocking beam **216**. The delivered oscillatory motion is changed to the rotational motion of the crankshaft **214** by the connecting rod **222**, wherein one end of the connecting rod **222** is rotatably coupled to a connecting pivot **240** positioned between an end pivot **232** and a rocker pivot **218** in the rocking beam **216**, and another end of the connecting rod **222** is rotatably coupled to crankpin **246**. The rocker pivot **218** may be positioned substantially at the midpoint between the end pivots **232** and **236** and oscillatorily support the rocking beam **216** as a fulcrum, thus guiding the respective piston rods **224** and **228** to make sufficient linear motion. In the exemplary embodiment, the crankshaft **214** is located above the rocking beam **216**, but in other embodiments, the crankshaft **214** may be positioned below the rocking beam **216** (as shown in FIGS. 5B and 5D) or in some embodiments, the crankshaft

214 is positioned to the side of the rocking beam 216, such that it still has a parallel axis to the rocking beam 216.

Still referring to FIGS. 2-4, the rocking beam oscillates about the rocker pivot 218, the end pivots 232 and 236 follow an arc path. Since the distal ends of the link rods 226 and 230 are connected to the rocking beam 216 at pivots 232 and 236, the distal ends of the link rods 226 and 230 also follow this arc path, resulting in an angular deviation 242 and 244 from the longitudinal axis of motion of their respective pistons 202 and 204. The coupling means 234 and 238 are configured such that any angular deviation 244 and 242 from the link rods 226 and 230 experienced by the piston rods 224 and 228 is minimized.

Essentially, the angular deviation 244 and 242 is absorbed by the coupling means 234 and 238 so that the piston rods 224 and 228 maintain substantially linear longitudinal motion to reduce side loads on the pistons 204 and 202. A stationary linear bearing 220 may also be placed inside the cylinder 208 or 206, or along coupling assemblies 212 or 210, to further absorb any angular deviation 244 or 242 thus keeping the piston push rod 224 or 228 and the piston 204 or 202 in linear motion along the longitudinal axis of the piston 204 or 202.

Therefore, in view of reciprocating motion of pistons 202 and 204, it is necessary to keep the motion of pistons 202 and 204 as close to linear as possible because the deviation 242 and 244 from longitudinal axis of reciprocating motion of pistons 202 and 204 causes noise, reduction of efficiency, increase of friction to the wall of cylinder, increase of side-load, and low durability of the parts. The alignment of the cylinders 206 and 208 and the arrangement of crankshaft 214, piston rods 224 and 228, link rods 226 and 230, and connecting rod 222, hence, may influence on, amongst other things, the efficiency and/or the volume of the device. For the purpose of increasing the linearity of the piston motion as mentioned, the pistons (shown as 202 and 204 in FIGS. 2-4) are preferably as close to the side of the respective cylinders 206 and 208 as possible.

In another embodiment reducing angular deviation of link rods, link rods 226 and 230 substantially linearly reciprocate along longitudinal axis of motion of respective pistons 204 and 202 to decrease the angular deviation and thus to decrease the side load applied to each piston 204 and 202. The angular deviation defines the deviation of the link rod 226 or 230 from the longitudinal axis of the piston 204 or 202. Numerals 244 and 242 designate the angular deviation of the link rods 226 and 230, as shown in FIG. 2. Therefore, the position of coupling assembly 212 influences the angular displacement of the link rod 226, based on the length of the distance between the end pivot 232 and the rocker pivot 218 of the rocking beam 216. Thus, the position of the coupling assemblies may be such that the

angular displacement of the link rod **226** is reduced. For the link rod **230**, the length of the coupling assembly **210** also may be determined and placed to reduce the angular displacement of the link rod **230**, based on the length of the distance between the end pivot **236** and the rocker pivot **218** of the rocking beam **216**. Therefore, the length of the link rods **226** and **230**, the length of coupling assemblies **212** and **210**, and the length of the rocking beam **216** are significant parameters that greatly influence and/or determine the angular deviation of the link rods **226** and **230** as shown in FIG. 2.

The exemplary embodiment has a straight rocking beam **216** having the end points **232** and **236**, the rocker pivot **218**, and the connecting pivot **240** along the same axis. However, in other embodiments, the rocking beam **216** may be bent, such that pistons may be placed at angles to each other, as shown in FIGS. 5C and 5D.

Referring now to FIGS. 2-4 and FIGS. 7A-7B, in some embodiments of the coupling assembly, the coupling assemblies **212** and **210**, may include a flexible link rod that is axially stiff but flexible in the rocking beam **216** plane of motion between link rods **226** and **230**, and pistons **204** and **202**, respectively. In this embodiment, at least one portion, the flexure (shown as **700** in FIGS. 7A and 7B), of link rods **226** and **230** is elastic. The flexure **700** acts as a coupling means between the piston rod and the link rod. The flexure **700** may absorb the crank-induced side loads of the pistons more effectively, thus allowing its respective piston to maintain linear longitudinal movement inside the piston's cylinder. This flexure **700** allows small rotations in the plane of the rocking beam **216** between the link rods **226** and **230** and pistons **204** or **202**, respectively. Although depicted in this embodiment as flat, which increases the elasticity of the link rods **226** and **230**, the flexure **700**, in some embodiments, is not flat. The flexure **700** also may be constructed near to the lower portion of the pistons or near to the distal end of the link rods **226** and **230**. The flexure **700**, in one embodiment, may be made of #D2 Tool Steel Hardened to 58-62 RC. In some embodiments, there may be more than one flexure (not shown) on the link rod **226** or **230** to increase the elasticity of the link rods.

In alternate embodiment, the axes of the pistons in each cylinder housing may extend in different directions, as depicted in FIGS. 5C and 5D. In the exemplary embodiment, the axes of the pistons in each cylinder housing are substantially parallel and preferably substantially vertical, as depicted in FIGS. 2 - 4, and FIGS. 5A and 5B. FIGS. 5A-5D include various embodiments of the rocking beam drive mechanism including like numbers as those shown and described with respect to FIGS. 2-4. It will be understood by

those skilled in that art that changing the relative position of the connecting pivot **240** along the rocking beam **216** will change the stroke of the pistons.

Accordingly, a change in the parameters of the relative position of the connecting pivot **240** in the rocking beam **216** and the length of the piston rods **224** and **228**, link rods **230** and **226**, rocking beam **216**, and the position of rocker pivot **218** will change the angular deviation of the link rods **226** and **230**, the phasing of the pistons **204** and **202**, and the size of the device **300** in a variety of manner. Therefore, in various embodiments, a wide range of piston phase angles and variable sizes of the engine may be chosen based on the modification of one or more of these parameters. In practice, the link rods **224** and **228** of the exemplary embodiment have substantially lateral movement within from -0.5 degree to +0.5 degree from the longitudinal axis of the pistons **204** and **202**. In various other embodiments, depending on the length of the link rod, the angle may vary anywhere from approaching 0 degrees to .75 degrees. However, in other embodiments, the angle may be higher including anywhere from approaching 0 to the approximately 20 degrees. As the link rod length increases, however, the crankcase/overall engine height increases as well as the weight of the engine.

One feature of the exemplary embodiment is that each piston has its link rod extending substantially to the attached piston rod so that it is formed as a coupling assembly. In one embodiment, the coupling assembly **212** for the piston **204** includes a piston rod **224**, a link rod **226**, and a coupling means **234** as shown in FIG. 2. More specifically, one proximal end of piston rod **224** is attached to the lower portion of piston **204** and the distal end piston rod **224** is connected to the proximate end of the link rod **226** by the coupling means **234**. The distal end of the link rod **226** extends vertically to the end pivot **232** of the rocking beam **216**. As described above, the coupling means **234** may be, but is not limited to, a joint, hinge, coupling, or flexure or other means known in the art. In this embodiment, the ratio of the piston rod **224** and the link rod **226** may determine the angular deviation of the link rod **226** as mentioned above.

In one embodiment of the machine, an engine, such as a Stirling engine, employs more than one rocking beam drive on a crankshaft. Referring now to FIG. 8, an unwrapped "four cylinder" rocking beam drive mechanism **800** is shown. In this embodiment, the rocking beam drive mechanism has four pistons **802**, **804**, **806**, and **808** coupled to two rocking beam drives **810** and **812**. In the exemplary embodiment, rocking beam drive mechanism **800** is used in a Stirling engine comprising at least four pistons **802**, **804**, **806**, and **808**, positioned in a quadrilateral arrangement coupled to a pair of rocking beam drives

**810** and **812**, wherein each rocking beam drive is connected to crankshaft **814**. However, in other embodiments, the Stirling cycle engine includes anywhere from 1-4 pistons, and in still other embodiments, the Stirling cycle engine includes more than 4 pistons. In some  
5 beam drives described above with respect to FIGS. 2-4 (shown as **210** and **212** in FIGS. 2 - 4). Although in this embodiment, the pistons are shown outside the cylinders, in practice, the pistons would be inside cylinders.

Still referring to FIG. 8, in some embodiments, the rocking beam drive mechanism **800** has a single crankshaft **814** having a pair of longitudinally spaced, radially and  
10 oppositely directed crank pins **816** and **818** adapted for being journaled in a housing, and a pair of rocking beam drives **810** and **812**. Each rocking beam **820** and **822** is pivotally connected to rocker pivots **824** and **826**, respectively, and to crankpins **816** and **818**, respectively. In the exemplary embodiment, rocking beams **820** and **822** are coupled to a rocking beam shaft **828**.

15 In some embodiments, a motor/generator may be connected to the crankshaft in a working relationship. The motor may be located, in one embodiment, between the rocking beam drives. In another embodiment, the motor may be positioned outboard. The term "motor/generator" is used to mean either a motor or a generator.

FIG. 9 shows one embodiment of crankshaft **814**. Positioned on the crankshaft is a  
20 motor/generator **900**, such as a Permanent Magnetic ("PM") generator. Motor/generator **900** may be positioned between, or inboard of the rocking beam drives (not shown, shown in FIG. 8 as **810** and **812**), or may be positioned outside, or outboard of, rocking beam drives **810** and **812** at an end of crankshaft **814**, as depicted by numeral **1000** in FIG 10A.

When motor/generator **900** is positioned between the rocking beam drives (not  
25 shown, shown in FIG. 8 as **810** and **812**), the length of motor/generator **900** is limited to the distance between the rocking beam drives. The diameter squared of motor/generator **900** is limited by the distance between the crankshaft **814** and the rocking beam shaft **828**. Because the capacity of motor/generator **900** is proportional to its diameter squared and length, these dimension limitations result in a limited-capacity "pancake" motor/generator **900** having  
30 relatively short length, and a relatively large diameter squared. The use of a "pancake" motor/generator **900** may reduce the overall dimension of the engine, however, the dimension limitations imposed by the inboard configuration result in a motor/generator having limited capacity.

Placing motor/generator **900** between the rocking beam drives exposes motor/generator **900** to heat generated by the mechanical friction of the rocking beam drives. The inboard location of motor/generator **900** makes it more difficult to cool motor/generator **900**, thereby increasing the effects of heat produced by motor/generator **900** as well as heat absorbed by motor/generator **900** from the rocking beam drives. This may lead to overheating, and ultimately failure of motor/generator **900**.

Referring to both FIGS. 8 and 9, the inboard positioning of motor/generator **900** may also lead to an unequilateral configuration of pistons **802**, **804**, **806**, and **808**, since pistons **802**, **804**, **806**, and **808** are coupled to rocking beam drives **810** and **812**, respectively, and any increase in distance would also result in an increase in distance between pistons **802**, **804**, and pistons **806** and **808**. An unequilateral arrangement of pistons may lead to inefficiencies in burner and heater head thermodynamic operation, which, in turn, may lead to a decrease in overall engine efficiency. Additionally, an unequilateral arrangement of pistons may lead to larger heater head and combustion chamber dimensions.

The exemplary embodiment of the motor/generator arrangement is shown in FIG. 10A. As shown in FIG. 10A, the motor/generator **1000** is positioned outboard from rocking beam drives **1010** and **1012** (shown as **810** and **812** in FIGS. 8) and at an end of crankshaft **1006**. The outboard position allows for a motor/generator **1000** with a larger length and diameter squared than the "pancake" motor/generator described above (shown as **900** in FIG. 9). As previously stated, the capacity of motor/generator **1000** is proportional to its length and diameter squared, and since outboard motor/generator **1000** may have a larger length and diameter squared, the outboard motor/generator **1000** configuration shown in FIG. 10A may allow for the use of a higher capacity motor/generator in conjunction with engine.

By placing motor/generator **1000** outboard of drives **1010** and **1012** as shown in the embodiment in FIG. 10A, motor/generator **1000** is not exposed to heat generated by the mechanical friction of drives **1010** and **1012**. Also, the outboard position of motor/generator **1000** makes it easier to cool the motor/generator, thereby allowing for more mechanical engine cycles per a given amount of time, which in turn allows for higher overall engine performance.

Also, as motor/generator **1000** is positioned outside and not positioned between drives **1010** and **1012**, rocking beam drives **1010** and **1012** may be placed closer together thereby allowing the pistons which are coupled to drives **1010** and **1012** to be placed in an equilateral arrangement. In some embodiments, depending on the burner type used,

particularly in the case of a single burner embodiment, equilateral arrangement of pistons allows for higher efficiencies in burner and heater head thermodynamic operation, which in turn allows higher overall engine performance. Equilateral arrangement of pistons also advantageously allows for smaller heater head and combustion chamber dimensions.

5 Referring again to FIGS. 8 and 9, crankshaft **814** may have concentric ends **902** and **904**, which in one embodiment are crank journals, and in various other embodiments, may be, but are not limited to, bearings. Each concentric end **902**, **904** has a crankpin **816**, **818** respectively, that may be offset from a crankshaft center axis. At least one counterweight **906** may be placed at either end of crankshaft **814** (shown as **1006** in FIG. 10A), to  
10 counterbalance any instability the crankshaft **814** may experience. This crankshaft configuration in combination with the rocking beam drive described above allows the pistons (shown as **802**, **804**, **806**, and **808** in FIG. 8) to do work with one rotation of the crankshaft **814**. This characteristic will be further explained below. In other embodiments, a flywheel (not shown) may be placed on crankshaft **814** (shown as **1006** in FIG. 10A) to  
15 decrease fluctuations of angular velocity for a more constant speed.

Still referring to FIGS. 8 and 9, in some embodiments, a cooler (not shown) may be also be positioned along the crankshaft **814** (shown as **1006** in FIG. 10A) and rocking beam drives **810** and **812** (shown as **1010** and **1012** in FIG. 10A) to cool the crankshaft **814** and rocking beam drives **810** and **812**. In some embodiments, the cooler may be used to cool  
20 the working gas in a cold chamber of a cylinder and may also be configured to cool the rocking beam drive. Various embodiments of the cooler are discussed in detail below.

FIGS. 10A-10G depict some embodiments of various parts of the machine. As shown in this embodiment, crankshaft **1006** is coupled to motor/generator **1000** via a motor/generator coupling assembly. Since motor/generator **1000** is mounted to crankcase  
25 **1008**, pressurization of crankcase with a charge fluid may result in crankcase deformation, which in turn may lead to misalignments between motor/generator **1000** and crankshaft **1006** and cause crankshaft **1006** to deflect. Because rocking beam drives **1010** and **1012** are coupled to crankshaft **1006**, deflection of crankshaft **1006** may lead to failure of rocking beam drives **1010** and **1012**. Thus, in one embodiment of the machine, a motor/generator  
30 coupling assembly is used to couple the motor/generator **1000** to crankshaft **1006**. The motor/generator coupling assembly accommodates differences in alignment between motor/generator **1000** and crankshaft **1006** which may contribute to failure of rocking beam drives **1010** and **1012** during operation.

Still referring to FIGS. 10A-10G, in one embodiment, the motor/generator coupling assembly is a spline assembly that includes spline shaft **1004**, sleeve rotor **1002** of motor/generator **1000**, and crankshaft **1006**. Spline shaft **1004** couples one end of crankshaft **1006** to sleeve rotor **1002**. Sleeve rotor **1002** is attached to motor/generator **1000** by mechanical means, such as press fitting, welding, threading, or the like. In one embodiment, spline shaft **1004** includes a plurality of splines on both ends of the shaft. In other embodiments, spline shaft **1004** includes a middle splineless portion **1014**, which has a diameter smaller than the outer diameter or inner diameter of splined portions **1016** and **1018**. In still other embodiments, one end portion of the spline shaft **1016** has splines that extend for a longer distance along the shaft than a second end portion **1018** that also includes splines thereon.

In some embodiments, sleeve rotor **1002** includes an opening **1020** that extends along a longitudinal axis of sleeve rotor **1002**. The opening **1020** is capable of receiving spline shaft **1004**. In some embodiments, opening **1020** includes a plurality of inner splines **1022** capable of engaging the splines on one end of spline shaft **1004**. The outer diameter **1028** of inner splines **1022** may be larger than the outer diameter **1030** of the splines on spline shaft **1004**, such that the fit between inner splines **1022** and the splines on spline shaft **1004** is loose (as shown in FIG. 10E). A loose fit between inner splines **1022** and the splines on spline shaft **1004** contributes to maintain spline engagement between spline shaft **1004** and rotor sleeve **1002** during deflection of spline shaft **1004**, which may be caused by crankcase pressurization. In other embodiments, longer splined portion **1016** of spline shaft **1004** may engage inner splines **1022** of rotor **1002**.

Still referring to FIGS. 10A-10G, in some embodiments, crankshaft **1006** has an opening **1024** on an end thereof, which is capable of receiving one end of spline shaft **1004**. Opening **1024** preferably includes a plurality of inner splines **1026** that engage the splines on spline shaft **1004**. The outer diameter **1032** of inner splines **1026** may be larger than the outer diameter **1034** of the splines on spline shaft **1004**, such that the fit between inner splines **1026** and the splines on spline shaft **1004** is loose (as shown in FIG. 10F). As previously discussed, a loose fit between inner splines **1026** and the splines on spline shaft **1004** contributes to maintain spline engagement between spline shaft **1004** and crankshaft **1006** during deflection of spline shaft **1004**, which may be caused by crankcase pressurization. The loose fit between the inner splines **1026** and **1022** on the crankshaft **1006** and the sleeve rotor **1002** and the splines on the spline shaft **1004** may contribute to maintain deflection of spline shaft **1004**. This may allow misalignments between crankshaft

**1006** and sleeve rotor **1002**. In some embodiments, shorter splined portion **1018** of spline shaft **1004** may engage opening **1024** of crankshaft **1006** thus preventing these potential misalignments.

In some embodiments, opening **1020** of sleeve rotor **1002** includes a plurality of  
5 inner splines that extend the length of opening **1020**. This arrangement contributes to spline shaft **1004** being properly inserted into opening **1020** during assembly. This contributes to proper alignment between the splines on spline shaft **1004** and the inner splines on sleeve rotor **1002** being maintained.

Referring now to FIG. 4, one embodiment of the engine is shown. Here the pistons  
10 **202** and **204** of engine **300** operate between a hot chamber **404** and a cold chamber **406** of cylinders **206** and **208** respectively. Between the two chambers there may be a regenerator **408**. The regenerator **408** may have variable density, variable area, and, in some embodiments, is made of wire. The varying density and area of the regenerator may be adjusted such that the working gas has substantially uniform flow across the regenerator  
15 **408**. Various embodiments of the regenerator **408** are discussed in detail below, and in U.S. Patents No. 6,591,609, issued July 17, 2003, to *Kamen et al.*, and No. 6,862,883, issued March 8, 2005, to *Kamen et al.*, which are herein incorporated by reference in their entireties. When the working gas passes through the hot chamber **404**, a heater head **410** may heat the gas causing the gas to expand and push pistons **202** and **204** towards the cold  
20 chamber **406**, where the gas compresses. As the gas compresses in the cold chamber **406**, pistons **202** and **204** may be guided back to the hot chamber to undergo the Stirling cycle again. The heater head **410** may be a pin head (as shown in FIGS. 52A through 53B), a fin head (as shown in FIGS. 56A through 56C), a folded fin head (as shown in FIGS. 56A through 56C), heater tubes as shown in FIG. 4 (also shown as **2904** in FIG. 29), or any other  
25 heater head embodiment known, including, but not limited to, those described below.

Various embodiments of heater head **410** are discussed in detail below, and in U.S. Patents No. 6,381,958, issued May 7, 2002, to *Kamen et al.*, No. 6,543,215, issued April 8, 2003, to *Langenfeld et al.*, No. 6,966,182, issued November 22, 2005, to *Kamen et al.*, and No. 7,308,787, issued December 18, 2007, to *LaRocque et al.*, which are herein incorporated by  
30 reference in their entireties.

In some embodiments, a cooler **412** may be positioned alongside cylinders **206** and **208** to further cool the gas passing through to the cold chamber **406**. Various embodiments of cooler **412** are discussed in detail in the proceeding sections, and in U.S. Patent No.

7,325,399, issued Feb. 5, 2008, to *Strimling et al*, which is herein incorporated by reference in its entirety.

In some embodiments, at least one piston seal **414** may be positioned on pistons **202** and **204** to seal the hot section **404** off from the cold section **406**. Additionally, at least one piston guide ring **416** may be positioned on pistons **202** and **204** to help guide the pistons' motion in their respective cylinders. Various embodiments of piston seal **414** and guide ring **416** are described in detail below, and in U.S. Patent Application Ser. No. 10/175,502, filed June 19, 2002, published February 6, 2003 (now abandoned), which is herein incorporated by reference in its entirety.

In some embodiments, at least one piston rod seal **418** may be placed against piston rods **224** and **228** to prevent working gas from escaping into the crankcase **400**, or alternatively into airlock space **420**. The piston rod seal **418** may be an elastomer seal, or a spring-loaded seal. Various embodiments of the piston rod seal **418** are discussed in detail below.

In some embodiments, the airlock space may be eliminated, for example, in the rolling diaphragm and/or bellows embodiments described in more detail below. In those cases, the piston rod seals **224** and **228** seal the working space from the crankcase.

In some embodiments, at least one rolling diaphragm/bellows **422** may be located along piston rods **224** and **228** to prevent airlock gas from escaping into the crankcase **400**. Various embodiments of rolling diaphragm **422** are discussed in more detail below.

Although FIG. 4 shows a cross section of engine **300** depicting only two pistons and one rocking beam drive, it is to be understood that the principles of operation described herein may apply to a four cylinder, double rocking beam drive engine, as designated generally by numeral **800** in FIG. 8.

## Piston Operation

Referring now to FIGS. 8 and 11, FIG. 11 shows the operation of pistons **802**, **804**, **806**, and **808** during one revolution of crankshaft **814**. With a  $\frac{1}{4}$  revolution of crankshaft **814**, piston **802** is at the top of its cylinder, otherwise known as top dead center, piston **806** is in upward midstroke, piston **804** is at the bottom of its cylinder, otherwise known as bottom dead center, and piston **808** is in downward midstroke. With a  $\frac{1}{2}$  revolution of crankshaft **814**, piston **802** is in downward midstroke, piston **806** is at top dead center, piston **804** is in upward midstroke, and piston **808** is at bottom dead center. With  $\frac{3}{4}$  revolution of crankshaft **814**, piston **802** is at bottom dead center, piston **806** is in downward midstroke, piston **804** is at top dead center, and piston **808** is in upward midstroke. Finally,

with a full revolution of crankshaft **814**, piston **802** is in upward midstroke, piston **806** is at bottom dead center, piston **804** is in downward midstroke, and piston **808** is at top dead center. During each  $\frac{1}{4}$  revolution, there is a 90 degree phase difference between pistons **802** and **806**, a 180 degree phase difference between pistons **802** and **804**, and a 270 degree phase difference between pistons **802** and **808**. FIG. 12A illustrates the relationship of the pistons being approximately 90 degrees out of phase with the preceding and succeeding piston. Additionally, FIG. 11 shows the exemplary embodiment machine means of transferring work. Thus, work is transferred from piston **802** to piston **806** to piston **804** to piston **808** so that with a full revolution of crankshaft **814**, all pistons have exerted work by moving from the top to the bottom of their respective cylinders.

Referring now to FIG. 11, together with FIGS. 12A-12C, illustrate the 90 degree phase difference between the pistons in the exemplary embodiment. Referring now to FIGS. 12A, although the cylinders are shown in a linear path, this is for illustration purposes only. In the exemplary embodiment of a four cylinder Stirling cycle machine, the flow path of the working gas contained within the cylinder working space follows a figure eight pattern. Thus, the working spaces of cylinders **1200**, **1202**, **1204**, and **1206** are connected in a figure eight pattern, for example, from cylinder **1200** to cylinder **1202** to cylinder **1204** to cylinder **1208**, the fluid flow pattern follows a figure eight. Still referring to FIG. 12A, an unwrapped view of cylinders **1200**, **1202**, **1204**, and **1206**, taken along the line B-B (shown in FIG. 12C) is illustrated. The 90 degree phase difference between pistons as described above allows for the working gas in the warm section **1212** of cylinder **1204** to be delivered to the cold section **1222** of cylinder **1206**. As piston **802** and **808** are 90 degrees out of phase, the working gas in the warm section **1214** of cylinder **1206** is delivered to the cold section **1216** of cylinder **1200**. As piston **802** and piston **806** are also 90 degrees out of phase, the working gas in the warm section **1208** of cylinder **1200** is delivered to the cold section **1218** of cylinder **1202**. And as piston **804** and piston **806** are also 90 degrees out of phase, so the working gas in the warm section **1210** of cylinder **1202** is delivered to the cold section **1220** of cylinder **1204**. Once the working gas of a warm section of a first cylinder enters the cold section of a second cylinder, the working gas begins to compress, and the piston within the second cylinder, in its down stroke, thereafter forces the compressed working gas back through a regenerator **1224** and heater head **1226** (shown in FIG. 12B), and back into the warm section of the first cylinder. Once inside the warm section of the first cylinder, the gas expands and drives the piston within that cylinder downward, thus causing the working gas within the cold section of that first cylinder to be driven through

the preceding regenerator and heater head, and into the cylinder. This cyclic transmigration characteristic of working gas between cylinders **1200**, **1202**, **1204**, and **1206** is possible because pistons **802**, **804**, **806**, and **808** are connected, via drives **810** and **812**, to a common crankshaft **814** (shown in FIG. 11), in such a way that the cyclical movement of each piston is approximately 90 degrees in advance of the movement of the proceeding piston, as depicted in FIG. 12A.

#### **Rolling Diaphragm, Metal Bellows, Airlock, and Pressure Regulator**

In some embodiments of the Stirling cycle machine, lubricating fluid is used. To prevent the lubricating fluid from escaping the crankcase, a seal is used.

Referring now to FIGS. 13A-15, some embodiments of the Stirling cycle machine include a fluid lubricated rocking beam drive that utilizes a rolling diaphragm **1300** positioned along the piston rod **1302** to prevent lubricating fluid from escaping the crankcase, not shown, but the components that are housed in the crankcase are represented as **1304**, and entering areas of the engine that may be damaged by the lubricating fluid. It is beneficial to contain the lubricating fluid for if lubricating fluid enters the working space, not shown, but the components that are housed in the working space are represented as **1306**, it would contaminate the working fluid, come into contact with the regenerator **1308**, and may clog the regenerator **1308**. The rolling diaphragm **1300** may be made of an elastomer material, such as rubber or rubber reinforced with woven fabric or non-woven fabric to provide rigidity. The rolling diaphragm **1300** may alternatively be made of other materials, such as fluorosilicone or nitrile with woven fabric or non-woven fabric. The rolling diaphragm **1300** may also be made of carbon nanotubes or chopped fabric, which is non-woven fabric with fibers of polyester or KEVLAR®, for example, dispersed in an elastomer. In the some embodiments, the rolling diaphragm **1300** is supported by the top seal piston **1328** and the bottom seal piston **1310**. In other embodiments, the rolling diaphragm **1300** as shown in FIG. 13A is supported via notches in the top seal piston **1328**.

In some embodiments, a pressure differential is placed across the rolling diaphragm **1300** such that the pressure above the seal **1300** is different from the pressure in the crankcase **1304**. This pressure differential inflates seal **1300** and allows seal **1300** to act as a dynamic seal as the pressure differential ensures that rolling diaphragm maintains its form throughout operation. FIGS. 13A, and FIGS. 13C-13H illustrate how the pressure differential effects the rolling diaphragm. The pressure differential causes the rolling diaphragm **1300** to conform to the shape of the bottom seal piston **1310** as it moves with the piston rod **1302**, and prevents separation of the seal **1300** from a surface of the piston **1310**

during operation. Such separation may cause seal failure. The pressure differential causes the rolling diaphragm **1300** to maintain constant contact with the bottom seal piston **1310** as it moves with the piston rod **1302**. This occurs because one side of the seal **1300** will always have pressure exerted on it thereby inflating the seal **1300** to conform to the surface of the bottom seal piston **1310**. In some embodiments, the top seal piston **1328** 'rolls over' the corners of the rolling diaphragm **1300** that are in contact with the bottom seal piston **1310**, so as to further maintain the seal **1300** in contact with the bottom seal piston **1310**. In the exemplary embodiment, the pressure differential is in the range of 10 to 15 PSI. The smaller pressure in the pressure differential is preferably in crankcase **1304**, so that the rolling diaphragm **1300** may be inflated into the crankcase **1304**. However, in other embodiments, the pressure differential may have a greater or smaller range of value.

The pressure differential may be created by various methods including, but not limited to, the use of the following: a pressurized lubrication system, a pneumatic pump, sensors, an electric pump, by oscillating the rocking beam to create a pressure rise in the crankcase **1304**, by creating an electrostatic charge on the rolling diaphragm **1300**, or other similar methods. In some embodiments, the pressure differential is created by pressurizing the crankcase **1304** to a pressure that is below the mean pressure of the working space **1306**. In some embodiments the crankcase **1304** is pressurized to a pressure in the range of 10 to 15 PSI below the mean pressure of the working space **1306**, however, in various other embodiments, the pressure differential may be smaller or greater. Further detail regarding the rolling diaphragm is included below.

Referring now to FIGS. 13C, 13G, and 13H, however, another embodiment of the Stirling machine is shown, wherein airlock space **1312** is located between working space **1306** and crankcase **1304**. Airlock space **1312** maintains a constant volume and pressure necessary to create the pressure differential necessary for the function of rolling diaphragm **1300** as described above. In one embodiment, airlock **1312** is not absolutely sealed off from working space **1306**, so the pressure of airlock **1312** is equal to the mean pressure of working space **1306**. Thus, in some embodiments, the lack of an effective seal between the working space and the crankcase contributes to the need for an airlock space. Thus, the airlock space, in some embodiments, may be eliminated by a more efficient and effective seal.

During operation, the working space **1306** mean pressure may vary so as to cause airlock **1312** mean pressure to vary as well. One reason the pressure may tend to vary is that during operation the working space may get hotter, which in turn may increase the pressure

in the working space, and consequently in the airlock as well since the airlock and working space are in fluid communication. In such a case, the pressure differential between airlock **1312** and crankcase **1304** will also vary, thereby causing unnecessary stresses in rolling diaphragms **1300** that may lead to seal failure. Therefore, some embodiments of the machine, the mean pressure within airlock **1312** is regulated so as to maintain a constant desired pressure differential between airlock **1312** and crankcase **1304**, and ensuring that rolling diaphragms **1300** stay inflated and maintains their form. In some embodiments, a pressure transducer is used to monitor and manage the pressure differential between the airlock and the crankcase, and regulate the pressure accordingly so as to maintain a constant pressure differential between the airlock and the crankcase. Various embodiments of the pressure regulator that may be used are described in further detail below, and in U.S. Patent No. 7,310,945, issued Dec. 25, 2007, to *Gurski et al.*, which is herein incorporated by reference in its entirety.

A constant pressure differential between the airlock **1312** and crankcase **1304** may be achieved by adding or removing working fluid from airlock **1312** via a pump or a release valve. Alternatively, a constant pressure differential between airlock **1312** and crankcase **1304** may be achieved by adding or removing working fluid from crankcase **1304** via a pump or a release valve. The pump and release valve may be controlled by the pressure regulator. Working fluid may be added to airlock **1312** (or crankcase **1304**) from a separate source, such as a working fluid container, or may be transferred over from crankcase **1304**. Should working fluid be transferred from crankcase **1304** to airlock **1312**, it may be desirable to filter the working fluid before passing it into airlock **1312** so as to prevent any lubricant from passing from crankcase **1304** into airlock **1312**, and ultimately into working space **1306**, as this may result in engine failure.

In some embodiments of the machine, crankcase **1304** may be charged with a fluid having different thermal properties than the working fluid. For example, where the working gas is helium or hydrogen, the crankcase may be charged with argon. Thus, the crankcase is pressurized. In some embodiments, helium is used, but in other embodiments, any inert gas, as described herein, may be used. Thus, the crankcase is a wet pressurized crankcase in the exemplary embodiment. In other embodiments where a lubricating fluid is not used, the crankcase is not wet.

In the exemplary embodiments, rolling diaphragms **1300** do not allow gas or liquid to pass through them, which allows working space **1306** to remain dry and crankcase **1304** to be wet sumped with a lubricating fluid. Allowing a wet sump crankcase **1304** increases

the efficiency and life of the engine as there is less friction in rocking beam drives **1316**. In some embodiments, the use of roller bearings or ball bearings in drives **1316** may also be eliminated with the use of lubricating fluid and rolling diaphragms **1300**. This may further reduce engine noise and increase engine life and efficiency.

5           FIGS. 14A-14E show cross sections of various embodiments of the rolling diaphragm (shown as **1400**, **1410**, **1412**, **1422** and **1424**) configured to be mounted between top seal piston and bottom seal piston (shown as **1328** and **1310** in FIGS. 13A and 13H), and between a top mounting surface and a bottom mounting surface (shown as **1320** and **1318** in FIG. 13A). In some embodiments, the top mounting surface may be the surface of  
10 an airlock or working space, and the bottom mounting surface may be the surface of a crankcase.

          FIG. 14A shows one embodiment of the rolling diaphragm **1400**, where the rolling diaphragm **1400** includes a flat inner end **1402** that may be positioned between a top seal piston and a bottom seal piston, so as to form a seal between the top seal piston and the  
15 bottom seal piston. The rolling diaphragm **1400** also includes a flat outer end **1404** that may be positioned between a top mounting surface and a bottom mounting surface, so as to form a seal between the top mounting surface and the bottom mounting surface. FIG. 14B shows another embodiment of the rolling diaphragm, wherein rolling diaphragm **1410** may include a plurality of bends **1408** leading up to flat inner end **1406** to provide for additional support and sealing contact between the top seal piston and the bottom seal piston. FIG. 14C shows  
20 another embodiment of the rolling diaphragm, wherein rolling diaphragm **1412** includes a plurality of bends **1416** leading up to flat outer end **1414** to provide for additional support and sealing contact between the top mounting surface and the bottom mounting surface.

          FIG. 14D shows another embodiment of the rolling diaphragm where rolling  
25 diaphragm **1422** includes a bead along an inner end **1420** thereof, so as to form an 'o-ring' type seal between a top seal piston and a bottom seal piston, and a bead along an outer end **1418** thereof, so as to form an 'o-ring' type seal between a bottom mounting surface and a top mounting surface. FIG. 14E shows another embodiment of the rolling diaphragm, wherein rolling diaphragm **1424** includes a plurality of bends **1428** leading up to beaded  
30 inner end **1426** to provide for additional support and sealing contact between the top seal piston and the bottom seal piston. Rolling diaphragm **1424** may also include a plurality of bends **1430** leading up to beaded outer end **1432** to provide for additional support and sealing contact between the top seal piston and the bottom seal piston.

Although FIGS. 14A through 14E depict various embodiments of the rolling diaphragm, it is to be understood that rolling diaphragms may be held in place by any other mechanical means known in the art.

Referring now to FIG. 15A, a cross section shows one embodiment of the rolling diaphragm embodiment. A metal bellows **1500** is positioned along a piston rod **1502** to seal off a crankcase (shown as **1304** in FIG. 13G) from a working space or airlock (shown as **1306** and **1312** in FIG. 13G). Metal bellows **1500** may be attached to a top seal piston **1504** and a stationary mounting surface **1506**. Alternatively, metal bellows **1500** may be attached to a bottom seal piston (not shown), and a top stationary mounting surface. In one embodiment the bottom stationary mounting surface may be a crankcase surface or an inner airlock or working space surface, and the top stationary mounting surface may be an inner crankcase surface, or an outer airlock or working space surface. Metal bellows **1500** may be attached by welding, brazing, or any mechanical means known in the art.

FIGS. 15B-15G depict a perspective cross sectional view of various embodiments of the metal bellows, wherein the metal bellows is a welded metal bellows **1508**. In some embodiments of the metal bellows, the metal bellows is preferably a micro-welded metal bellows. In some embodiments, the welded metal bellows **1508** includes a plurality of diaphragms **1510**, which are welded to each other at either an inner end **1512** or an outer end **1514**, as shown in FIGS. 15C and 15D. In some embodiments, diaphragms **1510** may be crescent shaped **1516**, flat **1518**, rippled **1520**, or any other shape known in the art.

Additionally, the metal bellows may alternatively be formed mechanically by means such as die forming, hydroforming, explosive hydroforming, hydramolding, or any other means known in the art.

The metal bellows may be made of any type of metal, including but not limited to, steel, stainless steel, stainless steel 374, AM-350 stainless steel, Inconel, Hastelloy, Haynes, titanium, or any other high-strength, corrosion-resistant material.

In one embodiment, the metal bellows used are those available from Senior Aerospace Metal Bellows Division, Sharon, MA, or American BOA, Inc., Cumming, GA.

#### **Rolling Diaphragm and/or Bellows Embodiments**

Various embodiments of the rolling diaphragm and/or bellows, which function to seal, are described above. Further embodiments will be apparent to those of skill in the art based on the description above and the additional description below relating to the parameters of the rolling diaphragm and/or bellows.

In some embodiments, the pressure atop the rolling diaphragm or bellows, in the airlock space or airlock area (both terms are used interchangeably), is the mean-working-gas pressure for the machine, which, in some embodiments is an engine, while the pressure below the rolling diaphragm and/or bellows, in the crankcase area, is ambient/atmospheric pressure. In these embodiments, the rolling diaphragm and/or bellows is required to operate with as much as 3000psi across it (and in some embodiments, up to 1500psi or higher). In this case, the rolling diaphragm and/or bellows seal forms the working gas (helium, hydrogen, or otherwise) containment barrier for the machine (engine in the exemplary embodiment). Also, in these embodiments, the need for a heavy, pressure-rated, structural vessel to contain the bottom end of the engine is eliminated, since it is now required to simply contain lubricating fluid (oil is used as a lubricating fluid in the exemplary embodiment) and air at ambient pressure, like a conventional internal combustion ("IC") engine.

The capability to use a rolling diaphragm and/or bellows seal with such an extreme pressure across it depends on the interaction of several parameters. Referring now to FIG. 15H, an illustration of the actual load on the rolling diaphragm or bellows material is shown. As shown, the load is a function of the pressure differential and the annular gap area for the installed rolling diaphragm or bellows seal.

**Region 1** represents the portions of the rolling diaphragm and/or bellows that are in contact with the walls formed by the piston and cylinder. The load is essentially a tensile load in the axial direction, due to the pressure differential across the rolling diaphragm and/or bellows. This tensile load due to the pressure across the rolling diaphragm and/or bellows can be expressed as:

$$L_t = P_d * A_a$$

Where

$L_t$  = Tensile Load and

$P_d$  = Pressure Differential

$A_a$  = Annular Area

and

$$A_a = \pi / 4 * (D^2 - d^2)$$

Where

$D$  = Cylinder Bore and

$d$  = Piston Diameter

The tensile component of stress in the bellows material can be approximated as:

$$S_t = L_t / (p * (D+d) * t_b)$$

Which reduces to:

$$S_t = P_d / 4 * (D-d) / t_b$$

Later, we will show the relationship of radius of convolution,  $R_c$ , to Cylinder bore (D) and

5 Piston Diameter (d) to be defined as:

$$R_c = (D-d)/4$$

So, this formula for  $S_t$  reduces to its final form:

$$S_t = P_d * R_c / t_b$$

Where

10  $t_b$  = thickness of bellows material

Still referring to FIG. 15H, **Region 2** represents the convolution. As the rolling diaphragm and/or bellows material turns the corner, in the convolution, the hoop stress imposed on the rolling diaphragm and/or bellows material may be calculated. For the

15 section of the bellows forming the convolution, the hoop component of stress can be closely approximated as:

$$S_h = P_d * R_c / t_b$$

The annular gap that the rolling diaphragm and/or bellows rolls within is generally referred to as the convolution area. The rolling diaphragm and/or bellows fatigue life is generally limited by the combined stress from both the tensile (and hoop) load, due to pressure differential, as well as the fatigue due to the bending as the fabric rolls through the convolution. The radius that the fabric takes on during this 'rolling' is defined here as the radius of convolution,  $R_c$ .

$$R_c = (D-d)/4$$

25 The bending stress,  $S_b$ , in the rolling diaphragm and/or bellows material as it rolls through the radius of convolution,  $R_c$ , is a function of that radius, as well as the thickness of the materials in bending. For a fiber-reinforced material, the stress in the fibers themselves (during the prescribed deflection in the exemplary embodiments) is reduced as the fiber diameter decreases. The lower resultant stress for the same level of bending allows for an increased fatigue life limit. As the fiber diameter is further reduced, flexibility to decrease the radius of convolution  $R_c$  is achieved, while keeping the bending stress in the fiber under its endurance limit. At the same time, as  $R_c$  decreases, the tensile load on the fabric is reduced since there is less unsupported area in the annulus between the piston and cylinder.

30

The smaller the fiber diameter, the smaller the minimum  $R_c$ , the smaller the annular area, which results in a higher allowable pressure differential.

For bending around a prescribed radius, the bending moment is approximated by:

$$M = E * I / R$$

5 Where:

$M$  = Bending Moment

$E$  = Elastic Modulus

$I$  = Moment of Inertia

$R$  = Radius of Bend

10 Classical bending stress,  $S_b$ , is calculated as:

$$S_b = M * Y / I$$

Where:

$Y$  = Distance above neutral axis of bending

Substituting yields:

$$15 \quad S_b = (E * I / R) * Y / I$$

$$S_b = E * Y / R$$

Assuming bending is about a central neutral axis:

$$Y_{\max} = t_b / 2$$

$$S_b = E * t_b / (2 * R)$$

20 In some embodiments, rolling diaphragm and/or bellows designs for high cycle life are based on geometry where the bending stress imposed is kept about one order of magnitude less than the pressure-based loading (hoop and axial stresses). Based on the equation:  $S_b = E * t_b / (2 * R)$ , it is clear that minimizing  $t_b$  in direct proportion to  $R_c$  should not increase the bending stress. The minimum thickness for the exemplary

25 embodiments of the rolling diaphragm and/or bellows material or membrane is directly related to the minimum fiber diameter that is used in the reinforcement of the elastomer. The smaller the fibers used, the smaller resultant  $R_c$  for a given stress level.

Another limiting component of load on the rolling diaphragm and/or bellows is the hoop stress in the convolution (which is theoretically the same in magnitude as the axial

30 load while supported by the piston or cylinder). The governing equation for that load is as follows:

$$S_h = P_d * R_c / t_b$$

Thus, if  $R_c$  is decreased in direct proportion to  $t_b$ , then there is no increase of stress on the membrane in this region. However, if this ratio is reduced in a manner that decreases

Rc to a greater ratio than  $t_b$  then parameters must be balanced. Thus, decreasing  $t_b$  with respect to Rc requires the rolling diaphragm and/or bellows to carry a heavier stress due to pressure, but makes for a reduced stress level due to bending. The pressure-based load is essentially constant, so this may be favorable---since the bending load is cyclic, therefore it is the bending load component that ultimately limits fatigue life.

For bending stress reduction,  $t_b$  ideally should be at a minimum, and Rc ideally should be at a maximum. E ideally is also at a minimum. For hoop stress reduction, Rc ideally is small, and  $t_b$  ideally is large.

Thus, the critical parameters for the rolling diaphragm and/or bellows membrane material are:

E, Elastic Modulus of the membrane material;

$t_b$ , membrane thickness (and/or fiber diameter);

Sut, Ultimate tensile strength of the rolling diaphragm and/or bellows; and

Slcf, The limiting fatigue strength of the rolling diaphragm and/or bellows.

Thus, from E,  $t_b$  and Sut, the minimum acceptable Rc may be calculated. Next, using Rc, Slcf, and  $t_b$ , the maximum Pd may be calculated. Rc may be adjusted to shift the bias of load (stress) components between the steady state pressure stress and the cyclic bending stress. Thus, the ideal rolling diaphragm and/or bellows material is extremely thin, extremely strong in tension, and very limber in flexion.

Thus, in some embodiments, the rolling diaphragm and/or bellows material (sometimes referred to as a "membrane"), is made from carbon fiber nanotubes. However, additional small fiber materials may also be used, including, but not limited to nanotube fibers that have been braided, nanotube untwisted yarn fibers, or any other conventional materials, including but not limited to KEVLAR, glass, polyester, synthetic fibers and any other material or fiber having a desirable diameter and/or other desired parameters as described in detail above.

### **Piston Seals and Piston Rod Seals**

Referring now to FIG. 13G, an embodiment of the machine is shown wherein an engine **1326**, such as a Stirling cycle engine, includes at least one piston rod seal **1314**, a piston seal **1324**, and a piston guide ring **1322**, (shown as **1616** in FIG. 16). Various embodiments of the piston seal **1324** and the piston guide ring **1322** are further discussed below, and in U.S. Patent Application Ser. No. 10/175,502 (now abandoned), which, as mentioned before, is incorporated by reference.

FIG. 16 shows a partial cross section of the piston **1600**, driven along the central axis **1602** of cylinder, or the cylinder **1604**. The piston seal (shown as **1324** in FIG. 13G) may include a seal ring **1606**, which provides a seal against the contact surface **1608** of the cylinder **1604**. The contact surface **1608** is typically a hardened metal (preferably 58-62 RC) with a surface finish of 12 RMS or smoother. The contact surface **1608** may be metal which has been case hardened, such as 8260 hardened steel, which may be easily case hardened and may be ground and/or honed to achieve a desired finish. The piston seal may also include a backing ring **1610**, which is sprung to provide a thrust force against the seal ring **1606** thereby providing sufficient contact pressure to ensure sealing around the entire outward surface of the seal ring **1606**. The seal ring **1606** and the backing ring **1610** may together be referred to as a piston seal composite ring. In some embodiments, the at least one piston seal may seal off a warm portion of cylinder **1604** from a cold portion of cylinder **1604**.

Referring now to FIG. 17, some embodiments include a piston rod seal (shown as **1314** in FIG. 13G) mounted in the piston rod cylinder wall **1700**, which, in some embodiments, may include a seal ring **1706**, which provides a seal against the contact surface **1708** of the piston rod **1604** (shown as **1302** in FIG. 13G). The contact surface **1708** in some embodiments is a hardened metal (preferably 58-62 RC) with a surface finish of 12 RMS or smoother. The contact surface **1708** may be metal which has been case hardened, such as **8260** hardened steel, which may be easily case hardened and may be ground and/or honed to achieve a desired finish. The piston seal may also include a backing ring **1710**, which is sprung to provide a radial or hoop force against the seal ring **1706** thereby providing sufficient contact hoop stress to ensure sealing around the entire inward surface of seal ring **1706**. The seal ring **1706** and the backing ring **1710** may together be referred to as a piston rod seal composite ring.

In some embodiments, the seal ring and the backing ring may be positioned on a piston rod, with the backing exerting an outward pressure on the seal ring, and the seal ring may come into contact with a piston rod cylinder wall **1702**. These embodiments require a larger piston rod cylinder length than the previous embodiment. This is because the contact surface on the piston rod cylinder wall **1702** will be longer than in the previous embodiment, where the contact surface **1708** lies on the piston rod itself. In yet another embodiment, piston rod seals may be any functional seal known in the art including, but not limited to, an o-ring, a graphite clearance seal, graphite piston in a glass cylinder, or any air pot, or a spring energized lip seal. In some embodiments, anything having a close clearance

may be used, in other embodiments, anything having interference, for example, a seal, is used. In the exemplary embodiment, a spring energized lip seal is used. Any spring energized lip seal may be used, including those made by BAL SEAL Engineering, Inc., Foothill Ranch, CA. In some embodiments, the seal used is a BAL SEAL Part Number  
5 X558604.

The material of the seal rings **1606** and **1706** is chosen by considering a balance between the coefficient of friction of the seal rings **1606** and **1706** against the contact surfaces **1608** and **1708**, respectively, and the wear on the seal rings **1606** and **1706** it engenders. In applications in which piston lubrication is not possible, such as at the high  
10 operating temperatures of a Stirling cycle engine, the use of engineering plastic rings is used. The embodiments of the composition include a nylon matrix loaded with a lubricating and wear-resistant material. Examples of such lubricating materials include PTFE/silicone, PTFE, graphite, etc. Examples of wear-resistant materials include glass fibers and carbon fibers. Examples of such engineering plastics are manufactured by LNP Engineering  
15 Plastics, Inc. of Exton, PA. Backing rings **1610** and **1710** is preferably metal.

The fit between the seal rings **1606** and **1706** and the seal ring grooves **1612** and **1712**, respectively, is preferably a clearance fit (about 0.002"), while the fit of the backing rings **1610** and **1710** is preferably a looser fit, of the order of about 0.005" in some  
20 embodiments. The seal rings **1606** and **1706** provide a pressure seal against the contact surfaces **1608** and **1708**, respectively, and also one of the the surfaces **1614** and **1714** of the seal ring grooves **1612** and **1712**, respectively, depending on the direction of the pressure difference across the rings **1606** and **1706** and the direction of the piston **1600** or the piston rod **1704** travel.

FIGS. 18A and 18B show that if the backing ring **1820** is essentially circularly  
25 symmetrical, but for the gap **1800**, it will assume, upon compression, an oval shape, as shown by the dashed backing ring **1802**. The result may be an uneven radial or hoop force (depicted by arrows **1804**) exerted on the seal ring (not shown, shown as **1606** and **1706** in FIGS. 16 and 17), and thus an uneven pressure of the seal rings against the contact surfaces (not shown, shown as **1608** and **1708** in FIGS. 16 and 17) respectively, causing uneven  
30 wear of the seal rings and in some cases, failure of the seals.

A solution to the problem of uneven radial or hoop force exerted by the piston seal backing ring **1820**, in accordance with an embodiment, is a backing ring **1822** having a cross-section varying with circumferential displacement from the gap **1800**, as shown in FIGS. 18C and 18D. A tapering of the width of the backing ring **1822** is shown from the

position denoted by numeral **1806** to the position denoted by numeral **1808**. Also shown in FIGS. 18C and 18D is a lap joint **1810** providing for circumferential closure of the seal ring **1606**. As some seals will wear significantly over their lifetime, the backing ring **1822** should provide an even pressure (depicted by numeral **1904** in FIG. 19B) of a range of movement. The tapered backing ring **1822** shown in FIGS. 18C and 18D may provide this advantage.

FIGS. 19A and 19B illustrate another solution to the problem of uneven radial or hoop force of the piston seal ring against the piston cylinder, in accordance with some embodiments. As shown in FIG. 19A, backing ring **1910** is fashioned in an oval shape, so that upon compression within the cylinder, the ring assumes the circular shape shown by dashed backing ring **1902**. A constant contact pressure between the seal ring and the cylinder contact surface may thus be provided by an even radial force **1904** of backing ring **1902**, as shown in FIG. 19B.

A solution to the problem of uneven radial or hoop force exerted by the piston rod seal backing ring, in accordance with some embodiments, is a backing ring **1824** having a cross-section varying with circumferential displacement from gap **1812**, as shown in FIGS. 18E and 18F. A tapering of the width of backing ring **1824** is shown from the position denoted by numeral **1814** to the position denoted by numeral **1816**. Also shown in FIGS. 18E and 18F is a lap joint **1818** providing for circumferential closure of seal ring **1706**. As some seals will wear significantly over their lifetime, backing ring **1824** should provide an even pressure (depicted by numeral **2004** in FIG. 20B) of a range of movement. The tapered backing ring **1824** shown in FIGS. 18E and 18F may provide this advantage.

FIGS. 20A and 20B illustrate another solution to the problem of uneven radial or hoop force of the piston rod seal ring against the piston rod contact surface, in accordance with some embodiments. As shown in FIG. 20A, backing ring (shown by dashed backing ring **2000**) is fashioned as an oval shape, so that upon expansion within the cylinder, the ring assumes the circular shape shown by backing ring **2002**. A constant contact pressure between the seal ring **1706** and the cylinder contact surface may thus be provided by an even radial thrust force **2004** of backing ring **2002**, as shown in FIG. 20B.

Referring again to FIG. 16, at least one guide ring **1616** may also be provided, in accordance with some embodiments, for bearing any side load on piston **1600** as it moves up and down the cylinder **1604**. Guide ring **1616** is also preferably fabricated from an engineering plastic material loaded with a lubricating material. A perspective view of guide

ring **1616** is shown in FIG. 21. An overlapping joint **2100** is shown and may be diagonal to the central axis of guide ring **1616**.

### **Lubricating Fluid Pump and Lubricating Fluid Passageways**

Referring now to FIG. 22, a representative illustration of one embodiment of the engine **2200** for the machine is shown having a rocking beam drive **2202** and lubricating fluid **2204**. In some embodiments, the lubricating fluid is oil. The lubricating fluid is used to lubricate engine parts in the crankcase **2206**, such as hydrodynamic pressure fed lubricated bearings. Lubricating the moving parts of the engine **2200** serves to further reduce friction between engine parts and further increase engine efficiency and engine life. In some embodiments, lubricating fluid may be placed at the bottom of the engine, also known as an oil sump, and distributed throughout the crankcase. The lubricating fluid may be distributed to the different parts of the engine **2200** by way of a lubricating fluid pump, wherein the lubricating fluid pump may collect lubricating fluid from the sump via a filtered inlet. In the exemplary embodiment, the lubricating fluid is oil and thus, the lubricating fluid pump is herein referred to as an oil pump. However, the term "oil pump" is used only to describe the exemplary embodiment and other embodiments where oil is used as a lubricating fluid, and the term shall not be construed to limit the lubricating fluid or the lubricating fluid pump.

Referring now to FIGS. 23A and 23B, one embodiment of the engine is shown, wherein lubricating fluid is distributed to different parts of the engine **2200** that are located in the crankcase **2206** by a mechanical oil pump **2208**. The oil pump **2208** may include a drive gear **2210** and an idle gear **2212**. In some embodiments, the mechanical oil pump **2208** may be driven by a pump drive assembly. The pump drive assembly may include a drive shaft **2214** coupled to a drive gear **2210**, wherein the drive shaft **2214** includes an intermediate gear **2216** thereon. The intermediate gear **2216** is preferably driven by a crankshaft gear **2220**, wherein the crankshaft gear **2220** is coupled to the primary crankshaft **2218** of the engine **2200**, as shown in FIG. 24. In this configuration, the crankshaft **2218** indirectly drives the mechanical oil pump **2208** via the crankshaft gear **2220**, which drives the intermediate gear **2216** on the drive shaft **2214**, which, in turn, drives the drive gear **2210** of the oil pump **2208**.

The crankshaft gear **2220** may be positioned between the crankpins **2222** and **2224** of crankshaft **2218** in some embodiments, as shown in FIG. 24. In other embodiments, the crankshaft gear **2220** may be placed at an end of the crankshaft **2218**, as shown in FIGS. 25A - 25C.

For ease of manufacturing, the crankshaft **2218** may be composed of a plurality of pieces. In these embodiments, the crankshaft gear **2220** may be to be inserted between the crankshaft pieces during assembly of the crankshaft.

The drive shaft **2214**, in some embodiments, may be positioned perpendicularly to the crankshaft **2218**, as shown in FIGS. 23A and 25A. However, in some embodiments, the drive shaft **2214** may be positioned parallel to the crankshaft **2218**, as shown in FIGS. 25B and 25C.

In some embodiments, the crankshaft gear **2234** and the intermediate gear **2232** may be sprockets, wherein the crankshaft gear **2234** and the intermediate gear **2232** are coupled by a chain **2226**, as shown in FIGS. 25C and 26C. In such an embodiments, the chain **2226** is used to drive a chain drive pump (shown as **2600** in FIGS. 26A through 26C).

In some embodiments, the gear ratio between the crankshaft **2218** and the drive shaft **2214** remains constant throughout operation. In such an embodiment, it is important to have an appropriate gear ratio between the crankshaft and the drive shaft, such that the gear ratio balances the pump speed and the speed of the engine. This achieves a specified flow of lubricant required by a particular engine RPM (revolutions per minute) operating range.

In some embodiments, lubricating fluid is distributed to different parts of an engine by an electric pump. The electric pump eliminates the need for a pump drive assembly, which is otherwise required by a mechanical oil pump.

Referring back to FIGS. 23A and 23B, the oil pump **2208** may include an inlet **2228** to collect lubricating fluid from the sump and an outlet **2230** to deliver lubricating fluid to the various parts of the engine. In some embodiments, the rotation of the drive gear **2212** and the idle gear **2210** cause the lubricating fluid from the sump to be drawn into the oil pump through the inlet **2228** and forced out of the pump through the outlet **2230**. The inlet **2228** preferably includes a filter to remove particulates that may be found in the lubricating fluid prior to its being drawn into the oil pump. In some embodiments, the inlet **2228** may be connected to the sump via a tube, pipe, or hose. In some embodiments, the inlet **2228** may be in direct fluid communication with the sump.

In some embodiments, the oil pump outlet **2230** is connected to a series of passageways in the various engine parts, through which the lubricating fluid is delivered to the various engine parts. The outlet **2230** may be integrated with the passageways so as to be in direct communication with the passageways, or may be connected to the passageways via a hose or tube, or a plurality of hoses or tubes. The series of passageways are preferably an interconnected network of passageways, so that the outlet **2230** may be connected to a

single passageway inlet and still be able to deliver lubricating fluid to the engine's lubricated parts.

FIGS 27A-27D show one embodiments, wherein the oil pump outlet (shown as **2230** in FIG. 23B) is connected to a passageway **2700** in the rocker shaft **2702** of the rocking beam drive **2704**. The rocker shaft passageway **2700** delivers lubricating fluid to the rocker pivot bearings **2706**, and is connected to and delivers lubricating fluid to the rocking beam passageways (not shown). The rocking beam passageways deliver lubricating fluid to the connecting wrist pin bearings **2708**, the link rod bearings **2710**, and the link rod passageways **2712**. The link rod passageways **2712** deliver lubricating fluid to the piston rod coupling bearing **2714**. The connecting rod passageway (not shown) of the connecting rod **2720** delivers lubricating fluid to a first crank pin **2722** and the crankshaft passageway **2724** of the crankshaft **2726**. The crankshaft passageway **2724** delivers lubricating fluid to the crankshaft journal bearings **2728**, the second crank pin bearing **2730**, and the spline shaft passageway **2732**. The spline shaft passageway **2732** delivers lubricating fluid to the spline shaft spline joints **2734** and **2736**. The oil pump outlet (not shown, shown in FIG. 23B as **2230**) in some embodiments is connected to the main feed **2740**. In some embodiments, an oil pump outlet may also be connected to and provide lubricating fluid to the coupling joint linear bearings **2738**. In some embodiments, an oil pump outlet may be connected to the linear bearings **2738** via a tube or hose, or plurality of tubes or hoses. Alternatively, the link rod passageways **2712** may deliver lubricating fluid to the linear bearings **2738**.

Thus, the main feed **2740** delivers lubricating fluid to the journal bearings surfaces **2728**. From the journal bearing surfaces **2728**, the lubricating fluid is delivered to the crankshaft main passage. The crankshaft main passage delivers lubricating fluid to both the spline shaft passageway **2732** and the connecting rod bearing on the crank pin **2724**.

Lubricating fluid is delivered back to the sump, preferably by flowing out of the aforementioned bearings and into the sump. In the sump, the lubricating fluid will be collected by the oil pump and redistributed throughout the engine.

#### Tube Heat Exchanger

External combustion engines, such as, for example, Stirling cycle engines, may use tube heater heads to achieve high power. FIG. 28 is a cross-sectional view of a cylinder and tube heater head of an illustrative Stirling cycle engine. A typical configuration of a tube heater head **2800**, as shown in FIG. 28, uses a cage of U-shaped heater tubes **2802** surrounding a combustion chamber **2804**. A cylinder **2806** contains a working fluid, such

as, for example, helium. The working fluid is displaced by the piston **2808** and driven through the heater tubes **2802**. A burner **2810** combusts a combination of fuel and air to produce hot combustion gases that are used to heat the working fluid through the heater tubes **2802** by conduction. The heater tubes **2802** connect a regenerator **2812** with the  
5 cylinder **2806**. The regenerator **2812** may be a matrix of material having a large ratio of surface to area volume which serves to absorb heat from the working fluid or to heat the working fluid during the cycles of the engine. Heater tubes **2802** provide a high surface area and a high heat transfer coefficient for the flow of the combustion gases past the heater tubes **2802**. Various embodiments of tube heater heads are discussed below, and in U.S.  
10 Patents No. 6,543,215 and No. 7,308,787, which are, as previously mentioned, incorporated by reference in their entireties.

FIG. 29 is a side view in cross section of a tube heater head and a cylinder. The heater head **2906** is substantially a cylinder having one closed end **2920** (otherwise referred to as the cylinder head) and an open end **2922**. Closed end **2920** includes a plurality of U-  
15 shaped heater tubes **2904** that are disposed in a burner **3036** (shown in FIG. 30). Each U-shaped tube **2904** has an outer portion **2916** (otherwise referred to herein as an "outer heater tube") and an inner portion **2918** (otherwise referred to herein as an "inner heater tube"). The heater tubes **2904** connect the cylinder **2902** to regenerator **2910**. Cylinder **2902** is disposed inside heater head **2906** and is also typically supported by the heater head **2906**. A  
20 piston **2924** travels along the interior of cylinder **2902**. As the piston **2924** travels toward the closed end **2920** of the heater head **2906**, working fluid within the cylinder **2902** is displaced and caused to flow through the heater tubes **2924** and regenerator **2910** as illustrated by arrows **2930** and **2932** in FIG. 29. A burner flange **2908** provides an attachment surface for a burner **3036** (shown in FIG. 30) and a cooler flange **2912** provides  
25 an attachment surface for a cooler (not shown).

Referring to FIG. 30, as mentioned above, the closed end of heater head **3006**, including the heater tubes **3004**, is disposed in a burner **3036** that includes a combustion chamber **3038**. Hot combustion gases (otherwise referred to herein as "exhaust gases") in combustion chamber **3038** are in direct thermal contact with heater tubes **3004** of heater  
30 head **3006**. Thermal energy is transferred by conduction from the exhaust gases to the heater tubes **3004** and from the heater tubes **3004** to the working fluid of the engine, typically helium. Other gases, such as nitrogen, for example, or mixtures of gases, may be used, with a preferable working fluid having high thermal conductivity and low viscosity. Non-combustible gases are used in various embodiments. Heat is transferred from the exhaust

gases to the heater tubes **3004** as the exhaust gases flow around the surfaces of the heater tubes **3004**. Arrows **3042** show the general radial direction of flow of the exhaust gases. Arrows **3040** show the direction of flow of the exhaust gas as it exits from the burner **3036**. The exhaust gases exiting from the burner **3036** tend to overheat the upper part of the heater tubes **3004** (near the U-bend) because the flow of the exhaust gases is greater near the upper part of the heater tubes than at the bottom of the heater tubes (i.e., near the bottom of the burner **3036**).

The overall efficiency of an external combustion engine is dependent in part on the efficiency of heat transfer between the combustion gases and the working fluid of the engine.

Returning to FIG. 29, in general, the inner heater tubes **2918** are warmer than the outer heater tubes **2916** by several hundred degrees Celsius. The burner power and thus the amount of heating provided to the working fluid is therefore limited by the inner heater tube **2918** temperatures. The maximum amount of heat will be transferred to the working gas if the inner and outer heater tubes are nearly the same temperature. Generally, embodiments, as described herein, either increase the heat transfer to the outer heater tubes or decrease the rate of heat transfer to the inner heater tubes.

FIG. 31 is a perspective view of an exhaust flow concentrator and a tube heater head in accordance with one embodiment. Heat transfer to a cylinder, such as a heater-tube, in cross-flow, is generally limited to only the upstream half of the tube. Heat transfer on the back side (or downstream half) of the tube, however, is nearly zero due to flow separation and recirculation. An exhaust flow concentrator **3102** may be used to improve heat transfer from the exhaust gases to the downstream side of the outer heater tubes by directing the flow of hot exhaust gases around the downstream side (i.e. the back side) of the outer heater tubes. As shown in FIG. 31, exhaust flow concentrator **3102** is a cylinder placed outside the bank of heater tubes **3104**. The exhaust flow concentrator **3102** may be fabricated from heat resistant alloys, preferably high nickel alloys such as Inconel 600, Inconel 625, Stainless Steels 310 and 316 and more preferably Hastelloy X. Openings **3106** in the exhaust flow concentrator **3102** are lined up with the outer heater tubes. The openings **3106** may be any number of shapes such as a slot, round hole, oval hole, square hole etc. In FIG. 31, the openings **3106** are shown as slots. In some embodiments, the slots **3106** have a width approximately equal to the diameter of a heater tube **3104**. The exhaust flow concentrator **3102** is preferably a distance from the outer heater tubes equivalent to one to two heater tube diameters.

FIG. 32 illustrates the flow of exhaust gases using the exhaust flow concentrator as shown in FIG. 31. As mentioned above, heat transfer is generally limited to the upstream side **3210** of a heater tube **3204**. Using the exhaust flow concentrator **3202**, the exhaust gas flow is forced through openings **3206** as shown by arrows **3212**. Accordingly, as shown in  
5 FIG. 32, the exhaust flow concentrator **3202** increases the exhaust gas flow **3212** past the downstream side **3214** of the heater tubes **3204**. The increased exhaust gas flow past the downstream side **3214** of the heater tubes **3204** improves the heat transfer from the exhaust gases to the downstream side **3214** of the heater tubes **3204**. This in turn increases the efficiency of heat transfer to the working fluid which can increase the overall efficiency and  
10 power of the engine.

Returning to FIG. 31, the exhaust flow concentrator **3102** may also improve the heat transfer to the downstream side of the heater tubes **3104** by radiation. Referring to FIG. 33, given enough heat transfer between the exhaust gases and the exhaust flow concentrator, the temperature of the exhaust flow concentrator **3302** will approach the temperature of the  
15 exhaust gases. In some embodiments, the exhaust flow concentrator **3302** does not carry any load and may therefore, operate at 1000.degree. C. or higher. In contrast, the heater tubes **3304** generally operate at 700.degree. C. Due to the temperature difference, the exhaust flow concentrator **3302** may then radiate thermally to the much cooler heater tubes **3304** thereby increasing the heat transfer to the heater tubes **3304** and the working fluid of  
20 the engine. Heat transfer surfaces (or fins) **3310** may be added to the exhaust flow concentrator **3302** to increase the amount of thermal energy captured by the exhaust flow concentrator **3302** that may then be transferred to the heater tubes by radiation. Fins **3310** are coupled to the exhaust flow concentrator **3302** at positions outboard of and between the openings **3306** so that the exhaust gas flow is directed along the exhaust flow concentrator,  
25 thereby reducing the radiant thermal energy lost through each opening in the exhaust flow concentrator. The fins **3310** are preferably attached to the exhaust flow concentrator **3302** through spot welding. Alternatively, the fins **3310** may be welded or brazed to the exhaust flow concentrator **3302**. The fins **3310** should be fabricated from the same material as the exhaust flow concentrator **3302** to minimize differential thermal expansion and subsequent  
30 cracking. The fins **3310** may be fabricated from heat resistant alloys, preferably high nickel alloys such as Inconel 600, Inconel 625, Stainless Steels 310 and 316 and more preferably Hastelloy X.

As mentioned above with respect to FIG. 30, the radial flow of the exhaust gases from the burner is greatest closest to the exit of the burner (i.e., the upper U-bend of the

heater tubes). This is due in part to the swirl induced in the flow of the exhaust gases and the sudden expansion as the exhaust gases exit the burner. The high exhaust gas flow rates at the top of the heater tubes creates hot spots at the top of the heater tubes and reduces the exhaust gas flow and heat transfer to the lower sections of the heater tubes. Local  
5 overheating (hot spots) may result in failure of the heater tubes and thereby the failure of the engine. FIG. 34 is a perspective view of an exhaust flow axial equalizer in accordance with an embodiment. The exhaust flow axial equalizer **3420** is used to improve the distribution of the exhaust gases along the longitudinal axis of the heater tubes **3404** as the exhaust gases flow radially out of the tube heater head. (The typical radial flow of the exhaust gases is  
10 shown in FIG. 30.) As shown in FIG. 34, the exhaust flow axial equalizer **3420** is a cylinder with openings **3422**. As mentioned above, the openings **3422** may be any number of shapes such as a slot, round hole, oval hole, square hole etc. The exhaust flow axial equalizer **3420** may be fabricated from heat resistant alloys, preferably high nickel alloys including Inconel 600, Inconel 625, Stainless Steels 310 and 316 and more preferably Hastelloy X.

15 In some embodiments, the exhaust flow axial equalizer **3420** is placed outside of the heater tubes **3404** and an exhaust flow concentrator **3402**. Alternatively, the exhaust flow axial equalizer **3420** may be used by itself (i.e., without an exhaust flow concentrator **3402**) and placed outside of the heater tubes **3404** to improve the heat transfer from the exhaust gases to the heater tubes **3404**. The openings **3422** of the exhaust flow axial equalizer **3420**,  
20 as shown in FIG. 34, are shaped so that they provide a larger opening at the bottom of the heater tubes **3404**. In other words, as shown in FIG. 34, the width of the openings **3422** increases from top to bottom along the longitudinal axis of the heater tubes **3404**. The increased exhaust gas flow area through the openings **3422** of the exhaust flow axial equalizer **3420** near the lower portions of the heater tubes **3404** counteracts the tendency of  
25 the exhaust gas flow to concentrate near the top of the heater tubes **3404** and thereby equalizes the axial distribution of the radial exhaust gas flow along the longitudinal axis of the heater tubes **3404**.

In another embodiment, as shown in FIG. 35, spacing elements **3504** may be added to an exhaust flow concentrator **3502** to reduce the spacing between the heater tubes **3506**.  
30 Alternatively, the spacing elements **3504** could be added to an exhaust flow axial equalizer **3520** (shown in FIG. 34) when it is used without the exhaust flow concentrator **3504**. As shown in FIG. 35, the spacing elements **3504** are placed inboard of and between the openings. The spacers **3504** create a narrow exhaust flow channel that forces the exhaust gas to increase its speed past the sides of heater tubes **3506**. The increased speed of the

combustion gas thereby increases the heat transfer from the combustion gases to the heater tubes **3506**. In addition, the spacing elements may also improve the heat transfer to the heater tubes **3506** by radiation.

FIG. 36 is a cross-sectional side view, of a tube heater head **3606** and burner **3608** in accordance with an alternative embodiment. In this embodiment, a combustion chamber of a burner **3608** is placed inside a set of heater tubes **3604** as opposed to above the set of heater tubes **3604** as shown in FIG. 30. A perforated combustion chamber liner **3615** is placed between the combustion chamber and the heater tubes **3604**. Perforated combustion chamber liner **3615** protects the inner heater tubes from direct impingement by the flames in the combustion chamber. Like the exhaust flow axial equalizer **3420**, as described above with respect to FIG. 34, the perforated combustion chamber liner **3615** equalizes the radial exhaust gas flow along the longitudinal axis of the heater tubes **3604** so that the radial exhaust gas flow across the top of the heater tubes **3604** (near the U-bend) is roughly equivalent to the radial exhaust gas flow across the bottom of the heater tubes **3604**. The openings in the perforated combustion chamber liner **3615** are arranged so that the combustion gases exiting the perforated combustion chamber liner **3615** pass between the inner heater tubes **3604**. Diverting the combustion gases away from the upstream side of the inner heater tubes **3604** will reduce the inner heater tube temperature, which in turn allows for a higher burner power and a higher engine power. An exhaust flow concentrator **3602** may be placed outside of the heater tubes **3604**. The exhaust flow concentrator **3602** is described above with respect to FIGS. 31 and 32.

Another method for increasing the heat transfer from the combustion gas to the heater tubes of a tube heater head so as to transfer heat, in turn, to the working fluid of the engine is shown in FIG. 37. FIG. 37 is a perspective view of a tube heater head including flow diverter fins in accordance with an embodiment. Flow diverter fins **3702** are used to direct the exhaust gas flow around the heater tubes **3704**, including the downstream side of the heater tubes **3704**, in order to increase the heat transfer from the exhaust gas to the heater tubes **3704**. Flow diverter fin **3702** is thermally connected to a heater tube **3704** along the entire length of the flow diverter fin. Therefore, in addition to directing the flow of the exhaust gas, flow diverter fins **3702** increase the surface area for the transfer of heat by conduction to the heater tubes **3704**, and thence to the working fluid.

FIG. 38 is a top view in cross-section of a tube heater head including flow diverter fins in accordance with an embodiment. Typically, the outer heater tubes **3806** have a large inter-tube spacing. Therefore, some embodiments as shown in FIG. 38, the flow diverter

fins **3802** are used on the outer heater tubes **3806**. In an alternative embodiment, the flow diverter fins could be placed on the inner heater tubes **3808** (also shown in FIG. 39 as **3908**). As shown in FIG. 38, a pair of flow diverter fins is connected to each outer heater tube **3806**. One flow diverter fin is attached to the upstream side of the heater tube and one flow diverter fin is attached to the downstream side of the heater tube. In some  
5       embodiments, the flow diverter fins **3802** are "L" shaped in cross section as shown in FIG. 38. Each flow diverter fin **3802** is brazed to an outer heater tube so that the inner (or upstream) flow diverter fin of one heater tube overlaps with the outer (or downstream) flow diverter fin of an adjacent heater tube to form a serpentine flow channel. The path of the  
10       exhaust gas flow caused by the flow diverter fins is shown by arrows **3814**. The thickness of the flow diverter fins **3802** decreases the size of the exhaust gas flow channel thereby increasing the speed of the exhaust gas flow. This, in turn, results in improved heat transfer to the outer heater tubes **3806**. As mentioned above, with respect to FIG. 37, the flow diverter fins **3802** also increase the surface area of the outer heater tubes **3806** for the  
15       transfer of heat by conduction to the outer heater tubes **3806**.

FIG. 39 is a cross-sectional top view of a section of the tube heater head of FIG. 37 in accordance with an embodiment. As mentioned above, with respect to FIG. 38, a pair of flow diverter fins **3902** is brazed to each of the outer heater tubes **3906**. In some  
20       embodiments, the flow diverter fins **3902** are attached to an outer heater tube **3906** using a nickel braze along the full length of the heater tube. Alternatively, the flow diverter fins could be brazed with other high temperature materials, welded or joined using other techniques known in the art that provide a mechanical and thermal bond between the flow diverter fin and the heater tube.

An alternative embodiment of flow diverter fins is shown in FIG. 40. FIG. 40 is a  
25       top view of a section of a tube heater head including single flow diverter fins in accordance with an embodiment. In this embodiment, a single flow diverter fin **4002** is connected to each outer heater tube **4004**. In some embodiments, the flow diverter fins **4002** are attached to an outer heater tube **4004** using a nickel braze along the full length of the heater tube. Alternatively, the flow diverter fins may be brazed with other high temperature materials,  
30       welded or joined using other techniques known in the art that provide a mechanical and thermal bond between the flow diverter fin and the heater tube. Flow diverter fins **4002** are used to direct the exhaust gas flow around the heater tubes **4004**, including the downstream side of the heater tubes **4004**. In order to increase the heat transfer from the exhaust gas to the heater tubes **4004**, flow diverter fins **4002** are thermally connected to the heater tube

4004. Therefore, in addition to directing the flow of exhaust gas, flow diverter fins 4002 increase the surface area for the transfer of heat by conduction to the heater tubes 4004, and thence to the working fluid.

FIG. 41 is a top view in cross-section of a section of a tube heater head including the single flow diverter fins as shown in FIG. 40 in accordance with an embodiment. As shown in FIG. 41, a flow diverter fin 4110 is placed on the upstream side of a heater tube 4106. The diverter fin 4110 is shaped so as to maintain a constant distance from the downstream side of the heater tube 4106 and therefore improve the transfer of heat to the heater tube 4106. In an alternative embodiment, the flow diverter fins could be placed on the inner heater tubes 4108.

Engine performance, in terms of both power and efficiency, is highest at the highest possible temperature of the working gas in the expansion volume of the engine. The maximum working gas temperature, however, is typically limited by the properties of the heater head. For an external combustion engine with a tube heater head, the maximum temperature is limited by the metallurgical properties of the heater tubes. If the heater tubes become too hot, they may soften and fail resulting in engine shut down. Alternatively, at too high of a temperature the tubes will be severely oxidized and fail. It is, therefore, important to engine performance to control the temperature of the heater tubes. A temperature sensing device, such as a thermocouple, may be used to measure the temperature of the heater tubes. The temperature sensor mounting scheme may thermally bond the sensor to the heater tube and isolate the sensor from the much hotter combustion gases. The mounting scheme should be sufficiently robust to withstand the hot oxidizing environment of the combustion-gas and impinging flame that occur near the heater tubes for the life of the heater head. One set of mounting solutions include brazing or welding thermocouples directly to the heater tubes. The thermocouples would be mounted on the part of the heater tubes exposed to the hottest combustion gas. Other possible mounting schemes permit the replacement of the temperature sensor. In one embodiment, the temperature sensor is in a thermowell thermally bonded to the heater tube. In another embodiment, the mounting scheme is a mount, such as a sleeve, that mechanically holds the temperature sensor against the heater tube.

FIG. 42 is a side view in cross section of a cylinder 4204 and a burner 4210. A temperature sensor 4202 is used to monitor the temperature of the heater tubes and provide feedback to a fuel controller (not shown) of the engine in order to maintain the heater tubes at the desired temperature. In some embodiments, the heater tubes are fabricated using Inconel 625 and the desired temperature is 930.degree. C. The desired temperature will be

different for other heater tube materials. The temperature sensor **4202** should be placed at the hottest, and therefore the limiting, part of the heater tubes. Generally, the hottest part of the heater tubes will be the upstream side of an inner heater tube **4206** near the top of the heater tube. FIG. 42 shows the placement of the temperature sensor **4202** on the upstream  
5 side of an inner heater tube **4206**. In some embodiments, as shown in FIG. 42, the temperature sensor **4202** is clamped to the heater tube with a strip of metal **4212** that is welded to the heater tube in order to provide good thermal contact between the temperature sensor **4202** and the heater tube **4206**. In one embodiment, both the heater tubes **4206** and the metal strip **4212** may be Inconel 625 or other heat resistant alloys such as Inconel 600,  
10 Stainless Steels 310 and 316 and Hastelloy X. The temperature sensor **4202** should be in good thermal contact with the heater tube, otherwise it may read too high a temperature and the engine will not produce as much power as possible. In an alternative embodiment, the temperature sensor sheath may be welded directly to the heater tube.

In another embodiment, as shown in FIG. 43A-B, a temperature sensor mount **4320**  
15 is created with a formed strip or sheath of a refractory or high temperature resistant metal such as Inconel that is bonded to the exterior of the heater tube **4310**. The sensor mount sheath **4320** is formed or shaped into a channel that when attached to the heater tube creates a void that accommodates a device. In a specific embodiment, the channel is V-shaped to accommodate the insertion of a thermal sensor such as a thermocouple device. The shaped  
20 channel is then bonded to the exterior of a heater tube **4310** as shown in FIG. 43A.

FIG. 43A shows a side view of the sensor mount sheath **4320** on the heater tube **4310**, while FIG. 43B is a view along the axis of the sensor mount sheath **4320**. The metal should be thin enough to form, yet thick enough to survive for the rated life of the heater head. In some embodiments, the metal is approximately between 0.005" and 0.020" thick.  
25 The metal may be bent such that the bend is along the length of the strip. This "V-channel" sheath **4320** is then affixed to the exterior of the heater tube by high temperature brazing. Prior to brazing, the sheath may be tack welded in several places to insure that the sheath does not move during the brazing process, as shown in FIG. 43A. Preferably, the braze compound used during brazing is typically a high nickel alloy; however, any compound  
30 which will withstand the brazing temperature will work. Alternatively the sheath may be bonded to the heater tube by electron beam or laser welding.

Now referring to FIG. 43B, a cavity **4330** is formed by affixing the sheath to the heater tube. This cavity **4330** is formed such that it may accept a device such as a thermocouple. When formed and brazed, the cavity may advantageously be sized to fit the

thermocouple. Preferably, the fit is such that the thermocouple is pressed against the exterior of the heater tube. Preferably, the sheath is thermally connected to the heater tube. If the sheath is not thermally connected to the heater tube, the sheath may not be "cooled" by the working gas. The lack of cooling may cause the sheath to operate at or near the combustion gas temperatures, which are typically high enough to eventually burn through any metal. Brazing the sensor mount to the heater tube leads to a good thermal contact. Alternatively, the sensor mount sheath **4320** could be continuously welded along both sides to provide sufficient thermal connection.

In another embodiment, as shown in FIGS. 44A-B, a second strip of metal can be formed to create a shield **4450** over the sensor mount **4420**. The shield **4420** may be used to improve the thermal connection between the temperature sensor, in cavity **4430**, and the heater tube **4410**. The shield insulates the sensor mount sheath **4420** from the convective heating of the hot combustion gases and thus improves the thermal connection to the heater tube. Furthermore, there is preferably an insulating space **4440** to help further insulate the temperature sensor from the hot combustion gases as shown in FIG. 44B.

In another specific embodiment, as shown in FIGS. 45A and 45B, the temperature sensor mount **4520** can be a small diameter tube or sleeve **4540** joined to the leading edge of the heater tube **4510**. FIG. 45A shows a side view of the mount on the heater tube **4510**, while FIG. 45B is a view along the axis of the tube **4540** or sleeve. The sensor tube **4540** is preferably brazed to the heater tube with a substantial braze fillet **4530**. The large braze fillet **4530** will maximize the thermal bond between the heater tube and the sensor mount. In another embodiment, the tube or sleeve **4540** may have a shield. As described supra, an outer shield cover may help insulate the temperature sensor mount **4520** from convective heat transfer and improve the thermal connection to the heater tube.

In an alternative embodiment of the tube heater head, the U-shaped heater tubes may be replaced with several helical wound heater tubes. Typically, fewer helical shaped heater tubes are required to achieve similar heat transfer between the exhaust gases and the working fluid. Reducing the number of heater tubes reduces the material and fabrication costs of the heater head. In general, a helical heater tube does not require the additional fabrication steps of forming and attaching fins. In addition, a helical heater tube provides fewer joints that could fail, thus increasing the reliability of the heater head.

FIGS. 46A-46D are perspective views of a helical heater tube in accordance some embodiments. The helical heater tube, **4602**, as shown in FIG. 46A, may be formed from a single long piece of tubing by wrapping the tubing around a mandrel to form a tight helical

coil **4604**. The tube is then bent around at a right angle to create a straight return passage out of the helix **4606**. The right angle may be formed before the final helical loop is formed so that the return can be clocked to the correct angle. FIGS. 46B and 46C show further views of the helical heater tube. FIG. 46D shows an alternative embodiment of the helical heater tube in which the straight return passage **4606** goes through the center of the helical coil **4604**. FIG. 47 shows a helical heater tube in accordance with one embodiment. In FIG. 47, the helical heater tube **4702** is shaped as a double helix. The heater tube **4702** may be formed using a U-shaped tube wound to form a double helix.

FIG. 48 is a perspective view of a tube heater head with helical heater tubes (as shown in FIG. 46A) in accordance with one embodiment. Helical heater tubes **4802** are mounted in a circular pattern on the top of a heater head **4803** to form a combustion chamber **4806** in the center of the helical heater tubes **4802**. The helical heater tubes **4802** provide a significant amount of heat exchange surface around the outside of the combustion chamber **4806**.

FIG. 49 is a cross sectional view of a burner and a tube heater head with helical heater tubes in accordance with some embodiments. Helical heater tubes **4902** connect the hot end of a regenerator **4904** to a cylinder **4905**. The helical heater tubes **4902** are arranged to form a combustion chamber **4906** (also shown in FIG. 50 as **5006**) for a burner **4907** that is mounted coaxially and above the helical heater tubes **4902**. Fuel and air are mixed in a throat **4908** of the burner **4907** and combusted in the combustion chamber **4906**. The hot combustion (or exhaust) gases flow, as shown by arrows **4914**, across the helical heater tubes **4902**, providing heat to the working fluid as it passes through the helical heater tubes **4902**.

In one embodiment, the heater head **4903** (also shown in FIG. 50 as **5003**) further includes a heater tube cap **4910** at the top of each helical coiled heater tubes **4902** to prevent the exhaust gas from entering the helical coil portion **4901** (also shown in FIG. 50 as **5001**) of each heater tube and exiting out the top of the coil. In another embodiment, an annular shaped piece of metal covers the top of all of the helical coiled heater tubes. The heater tube cap **4910** prevents the flow of the exhaust gas along the heater head axis to the top of the helical heater tubes between the helical heater tubes. In one embodiment, the heater tube cap **4910** may be Inconel 625 or other heat resistant alloys such as Inconel 600, Stainless Steels 310 and 316 and Hastelloy X.

In another embodiment, the top of the heater head **4903** under the helical heater tubes **4902** is covered with a moldable ceramic paste. The ceramic paste insulates the heater

head 4903 from impingement heating by the flames in the combustion chamber 4906 as well as from the exhaust gases. In addition, the ceramic blocks the flow of the exhaust gases along the heater head axis to the bottom of the helical heater tubes 4902 either between the helical heater tubes 4902 or inside the helical coil portion 4901 of each heater tube.

5 FIG. 50 is a top view of a tube heater head with helical heater tubes in accordance with one embodiment. As shown in FIG. 50, the return or straight section 5002 of each helical heater tube 5000 is advantageously placed outboard of gap 5009 between adjacent helical heater tubes 5000. It is important to balance the flow of exhaust gases through the helical heater tubes 5000 with the flow of exhaust gases through the gaps 5009 between the  
10 helical heater tubes 5000. By placing the straight portion 5002 of the helical heater tube outboard of the gap 5009, the pressure drop for exhaust gas passing through the helical heater tubes is increased, thereby forcing more of the exhaust gas through the helical coils where the heat transfer and heat exchange area are high. Exhaust gas that does not pass between the helical heater tubes will impinge on the straight section 5002 of the helical  
15 heater tube, providing high heat transfer between the exhaust gases and the straight section. Both FIGS. 49 and 50 show the helical heater tubes placed as close together as possible to minimize the flow of exhaust gas between the helical heater tubes and thus maximize heat transfer. In one embodiment, the helical coiled heater tubes 4901 may be arranged so that the coils nest together.

## 20 Pin or Fin Heat Exchanger

Now referring to FIGS. 51A and 51B, fins or pins may alternatively be used to increase the interfacial area between the hot fluid combustion products and the solid heater head so as to transfer heat, in turn, to the working fluid of the engine. Heater head 5100 may have heat transfer pins 5124, here shown on the interior surface of heater head 5100, in the  
25 space between the heater head and expansion cylinder liner 5115. Additionally, as shown in FIG. 51B in a cross section of Stirling cycle engine 5196 taken along a different diameter of expansion volume 5198 from that of FIG. 51A, heat transfer pins 5130 may also be disposed on the exterior surface of heater head 5100 so as to provide a large surface area for the transfer of heat by conduction to heater head 5100, and thence to the working fluid,  
30 from combustion gases flowing from combustor 5122 past the heat transfer pins. Dashed line 5131 represents the longitudinal axis of the expansion cylinder. FIG. 51B also shows heat transfer pins 5133 lining the interior and exterior surfaces of the top of heater head 5100, in accordance with one embodiment. Interior-facing heat transfer pins 5124 serve to provide a large surface area for the transfer of heat by conduction from heater head 5100 to

working fluid displaced from expansion volume **5198** by the expansion piston and driven through regenerator chamber **5132**. Additional embodiments of heater head **5100** are disclosed in U.S. Patents No. 6,381,958, and No. 6,966,182, which, as previously mentioned, are incorporated by reference in their entireties.

5 Depending on the size of heater head **5100**, hundreds or thousands of inner transfer pins **5124** and outer heat transfer pins **5130** may be desirable.

One method for manufacturing heater head **5100** with heat transfer pins **5124** and **5130** includes casting the heater head and pins (or other protuberances) as an integral unit. Casting methods for fabricating the heater head and pins as an integral unit include, for  
10 example, investment casting, sand casting, or die casting.

While the use of pin fins is known for improving heat transfer between a surface and a fluid, the integral casting of radial pin fins on the cylindrical heater head of a Stirling engine has not been practiced nor suggested in the art, despite the fact that casting the heater head and its heat exchange surfaces in a single step is one of the most cost effective  
15 methods to produce a heater head. The difficulty encountered in integral casting of radial pin fins is discussed further below. A pin fin that could be cast as part of cylindrical wall would allow the inexpensive fabrication of a highly effective heater head and/or cooler for a Stirling engine.

Castings are made by creating negative forms of the desired part. All forms of  
20 production casting (sand, investment and injection) involves forming extended surfaces and details by injecting material into a mold and then removing the mold from the material leaving the desired negative or positive form behind. Removing the mold from the material requires that all the extended surfaces are at least parallel. In fact, good design practice requires slight draft on these extended surfaces so that they release cleanly. Forming radial  
25 pins on the outside or inside of a cylinder would require the molds to contain tens or hundreds of parts that pull apart in different directions. Such a mold would be cost prohibitive.

In accordance various embodiments, pins or fins may be cast onto the inside and outside surface of Stirling heat exchangers using production sand, investment or metal  
30 injection casting methods. Referring to FIGS. 52A-52D and 53D, and, first, to FIG. 52A, pins **5202** are arranged into several groups **5208** of parallel pins **5202** around cylindrical wall **5210** of heater head **5100**, shown in cross section parallel to the central axis in FIG. 52B and in cross section transverse to the central axis, in FIG. 52C. It should be noted that the technology herein described may advantageously be applied more generally in any other

heat exchanger application. All the pins **5202** in each group **5208** are parallel to each other. Only the pins **5202** in the center of the group are truly radial. The pins on the outside of the group, such as those designated by numeral **5204** in FIGS. 52C and 53D, are angled inward from a local radius such as to be substantially parallel to a radial line **5212** toward the center of the group. In addition, the pins on the outside of the group are preferably longer, typically by a small amount, than pins closer to the center of the group. However, the heat transfer only changes only slightly from the center of the group to the outside in the embodiment depicted in FIGS. 52A-52C, and 53D in which 5 groups **5208** of parallel pins provide approximately radial pin fins around cylinder **5210**.

10 In the casting process in accordance with some embodiments, positive or negative molds of each group of parallel fins are formed in a single piece. Several mold pieces are then assembled to form the negative form for a sand casting. In investment mold casting, the wax positive can be formed in an injection mold with only a handful of separate parts that pull apart in different directions. The resulting mold is formed at an acceptable cost, thereby making production of a pin fin heater head economically practical.

15 Casting of a heater head having protuberances, such as pins, extending to the interior and exterior of a part with cylindrical walls may be achieved, in accordance with various embodiments, by investment, or lost-wax, casting, as well as by sand casting, die casting, or other casting processes. The interior or exterior protuberances, or both, may be integrally cast as part of the head.

20 While typically more cheaply accomplished than machining or assembly of the pin arrays, casting pin arrays may still have attendant difficulties and substantial costs. Additionally, the casting process may result in a heater head that is less than fully densely populated with pins, thus increasing the fraction of gases failing to collide with the heater head surface and reducing the efficiency of heat transfer.

25 One embodiment of the method for populating the surfaces of heater head **5100** with heat transfer pins entails fabrication of heater **5100** and arrays of heat transfer pins in separate fabrication processes. An array **5250** (also shown in FIG. 53B as **5350**) of heat transfer pins **5252** may be cast or injection molded with panel **5254** resulting in an integral backing panel structure shown in FIG. 52D. Pin arrays **5250**, after casting or molding, are mounted to the inner and outer surfaces of the heater head by a high temperature braze. Thus, a more densely populated head with a resultant low rate of gas leakage past the pins may advantageously be achieved. In other embodiments, panels **5254** may be secured by various mechanical means to the heater head.

Transient liquid-phase (TLP) bonding, as described, for example, in the Aerospace Structural Metals Handbook, Code 4218, p. 6 (1999) is particularly advantageous for brazing the panels to the head, since nickel based superalloys, typically employed for fabrication of the head, is difficult to weld by conventional processes, and operates in a high stress and high temperature environment. Advantages of TLP bonding in this application are that the parts braced by TLP are effectively welded using the parent material and have nearly the same tensile strength properties as integrally cast parts. TLP bonds do not remelt at elevated temperatures, whereas typical brazes will remelt at the brazing temperature. This is of particular significance in the case of continuous operation at elevated temperatures where temperature excursions may occur, as in the present application.

The panels **5254** of pins may be attached to the interior or exterior of either the heater head or the cooler by other means. In one alternative embodiment, the panel may be mechanically attached into slots at its lateral edges. The slots are provided in dividers **5306** (described in the following discussion). In another embodiment, the panels are attached to the heater head or cooler by brazing. In yet another embodiment, the panels are attached to the heater head or cooler by sintering the panels to the cylindrical walls of the heater head or cooler.

Dividers **5306**, as shown in FIGS. 52C, 53A, and 53B, may advantageously improve the heat transfer rate of the pin fin panels. Additionally, they may provide a convenient location for locating temperature sensors. Lastly, the dividers may advantageously provide a convenient structure to which to attach panels of pins to the heater head, in one embodiment, and a parting line for casting operations, in accordance with a further embodiment.

Dividers **5306** may serve to improve the thermal effectiveness of the pin fin arrays in the following manner. Referring, once again, to FIG. 52A, the rate of heat transfer for a fluid flowing through staggered pin fins is significantly higher than for fluid flowing through aligned pin fins. Fluid approaching a staggered pin array **5208** would travel at a 45-degree angle to an axial path along the length of the cylinder, with the skew direction designated by numeral **5214**. In order to provide for improved thermal transfer, dividers **5206**, **5306** are provided, in accordance some embodiments, to force the fluid flow through the staggered array of pin fins along a path designated by numeral **5212**. In addition to forcing the flow to travel axially, the dividers provide convenient interfaces and joining planes for the casting molds described above.

In certain embodiments, individual arrays **5250**, each with its associated panel segment **5254**, comprise arcuate fractions of the circumferential distance around the heater head. This is apparent in the top view of the heater head assembly shown in perspective in FIG. 53A. Cylinder head **5320** is shown, as is exterior surface **5302** of the heater head.

5 Backer segments supporting arrays of heat transfer pins are not shown but are inserted, during assembly, in spaces **5304** surrounding exterior surface **5302** of the heater head. Between successive heat transfer pin array segments are trapezoidal dividers **5306** which are baffled to block the flow of exhaust gases in a downward direction through any path other than past the heat transfer pins.

10 In one embodiment, flow dividers **5306** include structures for mechanically retaining the panel segments **5254** during assembly, before brazing, or simply to mechanically retain the panels **5254** against heater head **5302**.

In order to maximize engine power, the hottest part of the heater head is preferably at the highest temperature allowed, considering the metallurgical creep and tensile strength, stress, and appropriate factors of safety. Maintaining the hottest part of the heater head at the highest temperature requires measuring the temperature of the hottest part of the heater head. The dividers provide a convenient location and routing for temperature sensors on the heater had to any axial location along the pin fin arrays. Hot gas flow path **5313** (shown also in FIG. 51A), is defined, on the outside, by gas flow channel cover **5340**. Since exhaust gases do not flow through dividers **5306**, a temperature sensor, such as thermocouple **5138** (shown in FIGS. 51A and 53C) is advantageously disposed in divider **5306** in order to monitor the temperature of heater head **5100** with which the temperature sensor is in thermal contact. The position of pin arrays **5250** and temperature sensor **5138** mounted within divider **5306** is shown more clearly in the view of FIG. 53B in which the pin backer has been removed.

Temperature sensing device **5138** is preferably disposed within divider **5306** as depicted in FIG. 53B. More particularly, temperature sensing tip **5339** of temperature sensor **5138** is preferably located in the slot corresponding to divider **5306** as nearly as possible to cylinder head **5320** in that this area is typically the hottest part of the heater head.

30 Alternatively, temperature sensor **5138** may be mounted directly to cylinder head **5320**, however location of the sensor in the slot, as described, is used in some embodiments. Engine performance, in terms of both power and efficiency, is highest at the highest possible temperature, yet the maximum temperature is typically limited by metallurgical properties. Therefore, sensor **5138** should be placed to measure the temperature of the

hottest, and therefore the limiting, part of the heater head. Additionally, temperature sensor 5138 should be insulated from combustion gases and walls of divider 5306 by ceramic insulation 5342, as shown in FIG. 53C. The ceramic can also form an adhesive bond with the walls of the divider to retain the temperature sensor in place. Electrical leads 5344 of temperature sensor 5138 should also be electrically insulated.

Although the burner is designed to have circumferential symmetry, hot spots may develop on heater head 5320. Adding to the problem, the alloys typically employed for fabrication of the heater head, on account of their high melting point, have relatively poor thermal conductivity. Once hot spots form, they are apt to endure because the gas flow outside the head is axial rather than circumferential, since dividers 5306 (shown in FIG. 53A) impede any circumferential flow. Additionally, heating may increase local gas viscosity thereby redirecting more flow to other channels. In order to even out the temperature distribution on the heater head, a layer of highly thermally conductive metal, such as copper, of thickness greater than 0.001 in. and preferably about 0.005 in. is applied to interior surface 5348 of heater head 5320, by deposition or plating, or other application method. Alternatively, a similar coating may be applied to the exterior surface, in accordance with another embodiment.

In order to keep the size of the Stirling cycle engine small, it is important to maximize the heat flux from the combustion gas through the heater head. Whereas prior art employed loops of pipe in which heat transfer to the working fluid is achieved, loops engender both low reliability (since the loops are mechanically vulnerable) and higher cost, due to the more complicated loop geometry and extra materials. The limiting constraint on the heat flux are the thermo-mechanical properties of the heater head material that must be able to withstand the high temperatures of the combustion chamber while maintaining the structural integrity of the pressurized head. The maximum design temperature is determined by the hottest point on the heater head which is typically at the top of the wall. Ideally, the entire heater wall hot section would be at this maximum temperature, as may be controlled, for example, by controlling the fuel flow.

As combustion gases travel past the heater head in gas flow channels 5113, 5313 (shown in FIG. 51A), the gas temperature decreases as heat is transferred from the gas to the heater head. As a result, the maximum allowed heater head temperature at the top of the gas flow channel must be set by the material used for the heater head. The material is preferably chosen from the family of high nickel alloys, commonly known as super alloys, such as Inconel 600 (having a maximum temperature  $T_{sub,max} = 800$ .degree. C. before

softening), Inconel 625 (T.sub.max =900.degree. C.), Inconel 754 (T.sub.max =1080.degree. C.), or Hastelloy GMR 235 (T.sub.max =935.degree. C.). The gas in gas channel 5113, 5313 may cool by as much as 350.degree. C. on transit through the channel, resulting in underheating of the bottom of the hot zone.

5 In accordance with some embodiments, the temperature profile of the heater wall is controlled by means of heat transfer geometry, as now described. One method for controlling the geometry is by means of providing a variable cross-section gas flow channel **5113**, **5313** (shown in FIGS. 51A and 54A). The radial dimension (perpendicular to the wall of the heater head), and thus the cross-section of the channel, is large at the top of the heater  
10 wall, thereby allowing much of the gas to bypass the pin array at the top of the wall. The bypass allows hotter gas to reach the pin array at the bottom of the wall thereby allowing the bottom pin array to operate closer to its maximum temperature. The temperature gradient from the top of the heater to the bottom of the hot section (before regenerator volume **5132**, shown in FIG. 51A) has been reduced from as much as 350.degree. C. to 100.degree. C.  
15 using a variable cross-section gas flow channel.

A second method for controlling the geometry is by varying the population density and the geometry of the pin array as a function of position along the gas flow channel. The geometry of the pins may be adjusted by varying the height/diameter (H/D) ratio of the pins. If a casting process is used to form the pin array, the range of H/D ratios may be limited by  
20 the process. If pin rings are used, the range of H/D ratios may be extended.

Referring now to FIGS. 53E, 53F, 54A and 54B, arrow **5402** designates the path of heated exhaust gases past heater head 5100. Outer heat transfer pins **5130** intercept the heated exhaust gases and transfer heat via heater head **5100** and inner heat transfer pins **5124** to the working fluid that is driven from expansion cylinder **5115** along path **5404**. (For  
25 clarity, heat transfer pins **5130** and **5124** are shown schematically in FIG. 54A. Additional heat transfer pins **5130** and **5124** had been depicted, not to scale, in the view of FIGS. 53E, 53F, and 54B.) Successive heat transfer pins **5406**, **5408**, and **5410**, for example, present a progressively larger cross section to the flow of exhaust gas along path **5402**. Thus, while the exhaust gas has transferred some fraction of its heat prior to arrival at the lower pins,  
30 heat is extracted there with a greater conduction rate, thereby reducing the temperature gradient between the top **5412** and bottom **5414** of the path of working fluid between expansion volume **5198** and regenerator volume **5132**. Typical temperatures of the surface of expansion cylinder **5115** are indicated in FIG. 54A: 850.degree. C. at the top of the

cylinder, 750.degree. C. at the center of the cylinder, and 600.degree. C. at the end of the cylinder closest to the regenerator volume.

Another method for achieving more even distribution of heat from the exhaust gases to the heater head is to create a tapered divider on the outside diameter of the heater head by means of concentric tapered pin backer **5146**, as shown in FIG. 54A. The cross-sectional  
5 view of FIG. 54A shows how tapered pin backer **5146** allows some of the hottest exhaust gas to bypass the pins near the top of the heater head. Pin backer **5146** creates a narrowing annular gap on the outside of the pins that progressively forces more and more of the exhaust gases into the pin heat exchanger.

10 Another method for increasing the surface area of the interface between a solid such as heater head **5100** and a fluid such as combustion gases as discussed above is now described with reference to FIGS. 55A-55D. An effect analogous to that of fabricating heat transfer pins by casting or otherwise may be obtained by punching holes **5160** into a thin annular ring **5162** shown in top view in FIG. 55A and in side view in FIG. 55B. The  
15 thickness of ring **5162**, which may be referred to as a 'heat transfer pin ring' is comparable to the thickness of the heat transfer pins discussed above, and is governed by the strength of the heat-conductive material at the high temperature of the combustion gases traversing holes **5160**. The shape and disposition of holes **5160** within each ring is a matter of design for a particular application, indeed, holes **5160** may not be surrounded by solid material.  
20 The material of rings **5162** is preferably an oxidation-resistant metal such as Inconel 625 or Hastelloy GMR 235, though other heat-conducting materials may be used. Rings **5162** may be produced inexpensively by a metal stamping process. Rings **5162** are then mounted and brazed, or otherwise bonded, to the outer surface heater head **5100**, as shown with respect to outer pin rings **5164** in FIG. 55C, and with respect to inner pin rings **5166** in FIG. 55D.  
25 Additional rings may be interspersed between the pin rings to control the vertical spacing between the pins. Expansion cylinder liner **5115** is shown in the interior of inner pin rings **5166**.

Heat transfer rings **5162** may be advantageously applied to the interior of the heater head as well as to both the exterior and interior of the cooler of a thermal cycle engine. In  
30 these applications, the rings need not be oxidation resistant. Materials including copper and nickel are preferably used on the interior of the heater head, while the rings for the cooler are preferably made of one of various high thermal conductivity materials including aluminum, copper, zinc, etc.

The total cross sectional area of the heat transfer pins taken in a slice perpendicular to cylinder axis **5168** need not be constant, indeed, it is advantageously varied, as discussed in detail above, in reference to FIG. 54.

Referring to FIGS. 56A through 56C, the interior or exterior heat exchange surfaces may also be formed from various folded fin structures **5600**, **5602**, or **5604**. The folded fin structures may be made of material similar to that of the heater head pressure dome or of high thermal conductivity materials such as copper which may provide improved fin efficiency. Fins fabricated from high melting-point materials such as that of the heater head **5100** (shown in FIG. 51A) may be continuous from the top to the bottom of the heater head. Folded fins may be fabricated from sheet metal and brazed to the interior surface of the heater head. Three folded fin configurations are shown by way of example: wavy fins **5600**, lanced fins **5602**, and offset fins **5604**. In each case, the gas flow direction is indicated by an arrow designated by numeral **5606**.

Fins formed from a dissimilar metal to that of heater head **5100** are attached in axial segments to avoid differential thermal expansion from breaking the brazed joint between the fins and the head. The offset fin configuration of FIG. 56C advantageously provides a superior heat transfer coefficient to that of plain fins.

The use of high thermal conductivity metal for the folded fins may advantageously allow the fins to be made longer, thereby improving heat transfer and reducing resistance to flow of the gas and improving engine efficiency.

#### **Heater Head Support Ribs**

The walls of the heater head must be sufficiently strong, at operating temperatures, to withstand the elevated pressure of the working gas. It is typically desirable to operate Stirling cycle engines at as high a working gas pressure as possible, thus, enabling the head to withstand higher pressures is highly advantageous. In designing the heater head, it must be borne in mind that increasing the pressure at a given operating temperature typically requires increasing the heater head wall thickness in direct proportion. On the other had, thickening the heater head wall results in a longer thermal conduction path between the exterior heat source and the working gas.

Moreover, thermal conduction increases with heat exchanger surface area, thus thermal efficiency is increased by increasing the diameter of the heater head. Stress in the wall, however, is substantially proportional to the diameter of the head, thus increasing the head diameter, at a given temperature and interior gas pressure, requires increasing the wall thickness in direct proportion.

The strength considerations are tantamount at typical Stirling engine head temperatures, in fact, they drive the maximum operating temperature, since, as discussed, efficiency increases with temperature. Both creep and ultimate tensile strengths of materials tend to fall off precipitously when specified elevated temperatures are reached. Referring to FIG. 57A, the yield strength at 0.2% offset and ultimate tensile strength are shown for the GMR 235 nickel alloy in typical representation of the qualitative behavior of nickel alloys. Similarly, in FIG. 57B, it can be seen that the 0.01% per hour creep rate strength of GMR 235 falls from 40 ksi to half as the temperature rises from 1500.degree. F. to 1700.degree. F.

Some embodiments provide interior ribs (or hoops) **5800**, such as those disclosed in U.S. Patents No. 6,381,958, and No. 6,966,182, that enhance structural support of heater head **5801**, as shown in cross-section in FIG. 58. Ribs **5800** are characterized by an interior bore **5802**. The creep strength and rupture strength of heater head **5801** is thus determined predominantly by an effective thickness **5804** of the heater head and the interior bore diameter **5802**. Heat conduction through the heater head is not limited by thickness **5804** since intervening segments **5806** of the head are narrower and provide enhanced heat conduction. Ribs **5800** not only relieve hoop stresses on outer wall **5808** of head **5801** but additionally provide supplemental surface area interior to the heater head and thus advantageously enhance heat transfer to the working fluid.

Further advantages of providing ribs **5800** interior to the heater head include reducing the temperature gradient across the head wall **5808** for a given rate of heat transfer, as well as allowing operation at higher hot end working temperatures. Additionally, by reducing the stress requirements on the outer wall, alternative materials to nickel based superalloys may be used, advantageously providing superior conductivity at reduced cost.

A cross section of heater head **5801** with ribs **5800** is further shown in FIG. 59. Dashed line **5910** designates the central longitudinal axis of the expansion cylinder. In accordance with various embodiments expansion cylinder hot sleeve **5912** may have transverse flow diverters **5914** for directing the flow of working gas, represented by around **5916**, around circumferential ribs **5800** for enhancing heat transfer to the working gas. The additional width  $h$  of ribs **5800** contributes to the hoop strength of heater head **5101**, whereas heat transfer is governed predominantly by the narrower thickness  $t$  of outer heater head wall **5808**. In typical Stirling engine applications, while the heater head exterior may be run as hot as 1800.degree. F., ribs **5800** that provide structure strength typically run no hotter than 1300.degree. F.

Advantages of enhanced hoop strength concurrent with enhanced thermal conductivity, as discussed above with reference to FIG. 58 may additionally be obtained in accordance with several alternate embodiments. Referring to FIGS. 60A and 60B, cross sections are shown of a heater head **6030**, wherein tubular openings **6032** run parallel to heater head wall **6008**. As shown in the cross sectional view of FIG. 60B, taken along line AA, tubes **6032** allow working gas to pass down the wall, enhancing heat transfer from outside the head to the working gas. Additionally, the wall **6008** may be thicker, for the same rate of heat transfer, thus providing additional strength. Moreover, the thick wall section **6010** (also shown in FIG. 61B as **6110**) interior to passages **6032** remains cooler than would otherwise be the case, providing further additional strength. Heater head **6030** is preferably cast with tubular passages **6032** which may be round in cross section or of other shapes.

FIG. 61A shows a further heater head **6140** wherein tubular openings **6132** run parallel to heater head wall **6108** and are interrupted by openings that run out to thinner sections **6142** of the heater head wall. As shown in the cross sectional view of FIG. 62B, taken along line AA, tubes **6132** allow working gas to pass down the wall, enhancing heat transfer from outside the head to the working gas to a degree substantially enhanced over that of the straight tube design shown in FIGS. 62A and 62B. Additionally, openings **6144** provide additional area for removal of ceramic cores used in the casting process to create such long, thin holes. Increased access to the holes allows faster chemical leaching of the core in the course of the manufacturing process.

FIG. 62B shows yet another heater head **6250**, wherein ribs **6252** are disposed in a helix within heater head wall **6208**, thereby providing the wall with enhanced rigidity in both the circumferential and axial directions. The working gas flows through the spiral **6254** on a path between the expansion piston and the heater head, on its way to the regenerator. FIG. 62B shows a transverse cross section of the heater head of FIG. 62A taken along line AA. Various embodiments include employing a linear, or other, approximation to spiral **6254**, to obtain comparable advantages of stiffening and heat transfer.

Heater head **6250** of FIGS. 62A and 62B is preferably fabricated by casting. A side view of core assembly **6260** for use in the casting process is shown in FIG. 62C. It is additionally advantageous to provide ribs for internal support of the dome of the heater head and to provide additional heat exchange on the dome, thereby cooling the inner surface of the dome. The complementary core structure of the dome is shown in FIG. 62D, and, in

cross section, as viewed from the top, in FIG. 62D. A perspective view of core assembly **6260** is shown in FIG. 62E.

It is to be understood that the various heater head embodiments and methods for their manufacture described herein may be adapted to function in a multiple heater head  
5 configuration.

### Regenerator

A regenerator is used in a Stirling cycle machine, as discussed above and as described in U.S. Patents No. 6,591,609, and No. 6,862,883, to add and remove heat from the working fluid during different phases of the Stirling cycle. The regenerator used in a  
10 Stirling cycle machine must be capable of high heat transfer rates which typically suggests a high heat transfer area and low flow resistance to the working fluid. Low flow resistance also contributes to the overall efficiency of the engine by reducing the energy required to pump the working fluid. Additionally, a regenerator must be fabricated in such a manner as to resist spalling or fragmentation because fragments may be entrained in the working fluid  
15 and transported to the compression or expansion cylinders and result in damage to the piston seals.

One regenerator design uses several hundred stacked metal screens. While exhibiting a high heat transfer surface, low flow resistance and low spalling, metal screens may suffer the disadvantage that their cutting and handling may generate small metal  
20 fragments that must be removed before assembling the regenerator. Additionally, stainless steel woven wire mesh contributes appreciably to the cost of the Stirling cycle engine.

[0003] A three dimensional random fiber network, such as stainless steel wool or ceramic fiber, for example, may be used as the regenerator, as now described with reference to FIG. 63A. Stainless steel wool regenerator **6300** advantageously provides a large surface area to  
25 volume ratio, thereby providing favorable heat transfer rates at low fluid flow friction in a compact form. Additionally, cumbersome manufacturing steps of cutting, cleaning and assembling large numbers of screens are advantageously eliminated. The low mechanical strength of steel wool and the tendency of steel wool to spall may both be overcome as now described. In some embodiments, the individual steel wires **6302** and **6304** are “cross-  
30 linked” into a unitary 3D wire matrix.

[0004] The starting material for the regenerator may be fibrilose and of random fiber form such as either steel or nickel wool. The composition of the fiber may be a glass or a ceramic or a metal such as steel, copper, or other high temperature materials. The diameter of the fiber is preferably in the range from 10 micrometers to 1 millimeter depending on the size

of the regenerator and the properties of the metal. The starting material is placed into a form corresponding to the final shape of the regenerator which is depicted in cross-section in FIG. 63B. Inner canister cylindrical wall **6320**, outer canister cylindrical wall **6322**, and regenerator network **6300** are shown. The density of the regenerator is controlled by the amount of starting material placed in the form. The form may be porous to allow fluids to pass through the form.

In some embodiments, unsintered steel wool is employed as regenerator network **6300**. Regenerator network **6300** is then retained within the regenerator canister by regenerator retaining screens **6324** or other filter, thereby comprising a "basket" which may advantageously capture steel wool fragments.

In one embodiment, applicable to starting material that is electrically conducting, the starting material is placed in a porous form and placed in an electrolyte bath. The starting material may be a metal, such as stainless steel, for example. An electrical connection is made with the starting material thereby forming an electrode. Cross-linking of the individual fibers in the starting material is accomplished by electrically depositing a second material **6306** onto the starting material. The selection of the starting material will depend on such factors as the particular deposition technique chosen and the chemical compatibility of the first and second materials, as known to one of ordinary skill in the electrochemical art. During deposition, the second material will build up on the starting material and form bridges **6308** between the individual fibers of the starting material in places where the individual fibers are in close proximity to each other. The deposition is continued until the bridges have grown to a sufficient size to hold the two individual fibers rigidly in place.

The deposition duration depends on the particular deposition process and is easily determined by one of ordinary skill in the art. After the deposition is completed, the regenerator is removed from the bath and the form and is cleaned.

In another embodiment the starting material is placed in a form that may be porous or not. The form containing the starting material is placed in a furnace and is partially sintered into a unitary piece. The selection of the sintering temperature and sintering time is easily determined by one of ordinary skill in the sintering art.

In another embodiment the starting material is placed in a porous form. The form containing the starting material is placed in a chemical bath and a second material, such as nickel, is chemically deposited to form bridges between the individual fibers.

In another embodiment the starting material is a silica glass fiber which is placed into a porous form. The glass fiber and form is dipped in a solution of tetraethylorthosilicate

(TEOS) and ethanol so that the fiber is completely wetted by the solution. The fiber and form are removed from the solution and allowed to drain in a humid atmosphere. The solution will form meniscoidal shapes bridging fibers in close proximity to each other. The humidity of the atmosphere will start the hydrolysis-condensation reaction that converts the TEOS to silica forming a cross link between the two fibers. The fiber and form may be heat  
5 treated at a temperature less than 1000° C, most preferably less than 600° C, to remove the reactant products and form a silica bridge between the fibers.

In another embodiment a ceramic slurry is deposited onto a reticulated foam having the shape of the regenerator. The slurry is dried on the reticulated foam and heat treated to  
10 burn off the foam and sinter the ceramic. The ceramic may be composed of an oxide ceramic such as cordierite, alumina, or zirconia. The composition of the ceramic slurry and the heat treatment profile is easily specified by one of ordinary skill in the ceramic processing art.

In yet other embodiments, knit or woven wire is employed in fabrication of a  
15 regenerator as now described with reference to FIG. 64A . In accordance with these embodiments, knit or woven wire tube **6401** is flattened by rollers **6402** into tape **6404**, in which form it is wound about mandrel **6406** into annular layers **6408**. Stainless steel is advantageously used for knit wire tube **6401** because of its ability to withstand elevated temperature operation, and the diameter of the wire used is typically in the range of 1-2  
20 mils, however other materials and gauges may be used in various embodiments. Alternatively, a plurality, typically 5-10, of the stainless steel wires may be loosely wound into a multi-filament thread prior to knitting into a wire tube. This process advantageously strengthens the resulting tube **6401**. When mandrel **6406** is removed, annular assembly **6410** may be used as a regenerator in a thermal cycle engine.

25 Still another embodiment is now described with reference to FIGS. 64B through 64E. Knit or woven wire tube **6401**, shown in its right cylindrical form in FIG. 64B, is shown scored and partially compressed in FIG. 64C. Alternatively, the scoring may be at an angle **6414** with respect to the central axis **6412** of the tube, as shown in FIG. 64D. Tube **6401** is then axially compressed along central axis **6412** to form the bellows form **6416**  
30 shown in FIG. 64E that is then disposed as a regenerator within the regenerator volume **408** (shown in FIG. 4) of a Stirling cycle engine.

It is to be understood that the various regenerator embodiments and methods for their manufacture described herein may be adapted to function in a multiple cylinder configuration.

### Coolant Penetrating Cold-End Pressure Vessel

Referring now to FIGS. 65A-C, various cross-sections of an engine, such as a Stirling cycle engine, are shown in accordance with some embodiments. Engine **6500** is hermetically sealed. A crankcase **6502** serves as the cold-end pressure vessel and contains a charge gas in an interior volume **6504**. Crankcase **6502** can be made arbitrarily strong without sacrificing thermal performance by using sufficiently thick steel or other structural material. A heater head **6506** serves as the hot-end pressure vessel and is preferably fabricated from a high temperature super-alloy such as Inconel 625, GMR-235, etc. Heater head **6506** is used to transfer thermal energy by conduction from an external thermal source (not shown) to the working fluid. Thermal energy may be provided from various heat sources such as solar radiation or combustion gases. For example, a burner, as previously discussed, may be used to produce hot combustion gases (shown as **6507** in FIG. 65B) that are used to heat the working fluid. An expansion area of cylinder (or warm section) **6522** is disposed inside the heater head **6506** and defines part of a working gas volume as discussed above with respect to FIG. 1. A piston **6528** is used to displace the working fluid contained in the expansion area of cylinder **6522**.

In accordance with an embodiment, crankcase **6502** is welded directly to heater head **6506** at joints **6508** to create a pressure vessel that can be designed to hold any pressure without being limited, as are other designs, by the requirements of heat transfer in the cooler. In an alternative embodiment, the crankcase **6502** and heater head **6506** are either brazed or bolted together. The heater head **6506** has a flange or step **6510** that axially constrains the heater head and transfers the axial pressure force from the heater head **6506** to the crankcase **6502**, thereby relieving the pressure force from the welded or brazed joints **6508**. Joints **6508** serve to seal the crankcase **6502** (or cold-end pressure vessel) and bear the bending and planar stresses. In an alternative embodiment, the joints **6508** are mechanical joints with an elastomer seal. In yet another embodiment, step **6510** is replaced with an internal weld in addition to the exterior weld at joints **6508**.

Crankcase **6502** is assembled in two pieces, an upper crankcase **6512** and a lower crankcase **6516**. The heater head **6506** is first joined to the upper crankcase **6512**. Second, a cooler **6520** is installed with a coolant tubing (shown as **6514** in FIG. 65B) passing through holes in the upper crankcase **6512**. Third, the double acting pistons **6528** and drive components (designated generally as numeral **6540** in FIGS. 65A and 65C, not shown in FIG. 65B) are installed. In one embodiment, lower crankcase **6516** is assembled in three pieces, an upper section **6513**, a middle section **6515**, and a lower section **6517**, as shown in

FIGS. 65A and 65C. Middle section **6515** is may be connected to upper and lower sections **6513** and **6517** at joints **6519** and **6521**, respectively, by any mechanical means known in the art, or by welding.

The lower crankcase **6516** is then joined to the upper crankcase **6512** at joints **6518**.  
5 Preferably, the upper crankcase **6512** and the lower crankcase **6516** are joined by welding. Alternatively, a bolted flange may be employed (as shown in FIGS. 65B and 65C).

In some embodiments a motor/generator (shown as **6501** in FIG. 65C), such as a PM generator, may be installed into motor/generator housing (shown as **6503** in FIG. 65C), which is attached to the lower crankcase **6516**, as shown in FIG. 65C. Motor/generator  
10 housing **6503** may be attached to lower crankcase **6516** by any mechanical means known in the art, or may be welded to lower crankcase **6516**. Motor/generator housing **6503** may assembled in two pieces, a front section **6505**, which is attached to lower crankcase **6516**, and a rear section **6509**, which may be welded or bolted to front section **6505**. In one embodiment a seal **6511** may be positioned between the rear section **6509** and the front  
15 section **6505** of the motor/generator housing **6503**. In some embodiments rear section **6509** is removable attached to front section **6505**, which serves, among other functions, to allow for easy removal and installation of motor/generator **6501** during engine **6500** assembly.

In order to allow direct coupling of the heater head **6506** to the upper crankcase **6512**, the cooling function of the thermal cycle is performed by a cooler **6520** that is  
20 disposed within the crankcase **6502**, thereby advantageously reducing the pressure containment requirements placed upon the cooler. By placing the cooler **6520** within crankcase **6502**, the pressure across the cooler is limited to the pressure difference between the working gas in the working gas volume, and the charge gas in the interior volume **6504** of the crankcase. The difference in pressure is created by the compression and expansion of  
25 the working gas, and is typically limited to a percentage of the operating pressure. In one embodiment, the pressure difference is limited to less than 30% of the operating pressure.

Coolant tubing **6514** advantageously has a small diameter relative to the diameter of the cooler **6520**. The small diameter of the coolant passages, such as provided by coolant tubing **6514**, is key to achieving high heat transfer and supporting large pressure  
30 differences. The required wall thickness to withstand or support a given pressure is proportional to the tube or vessel diameter. The low stress on the tube walls allows various materials to be used for coolant tubing **6514** including, but not limited to, thin-walled stainless steel tubing or thicker-walled copper tubing.

An additional advantage of locating the cooler **6520** entirely within the crankcase **6502** (or cold-end pressure vessel) volume is that any leaks of the working gas through the cooler **6520** will only result in a reduction of engine performance. In contrast, if the cooler were to interface with the external ambient environment, a leak of the working gas through the cooler would render the engine useless due to loss of the working gas unless the mean pressure of working gas is maintained by an external source. The reduced requirement for a leak-tight cooler allows for the use of less expensive fabrication techniques including, but not limited to, powder metal and die casting.

Cooler **6520** is used to transfer thermal energy by conduction from the working gas and thereby cool the working gas. A coolant, either water or another fluid, is carried through the crankcase **6502** and the cooler **6520** by coolant tubing **6514**. The feedthrough of the coolant tubing **6514** through upper crankcase **6512** may be sealed by a soldered or brazed joint for copper tubes, welding, in the case of stainless steel and steel tubing, or as otherwise known in the art.

The charge gas in the interior volume **6504** may also require cooling due to heating resulting from heat dissipated in the motor/generator windings, mechanical friction in the drive, the non-reversible compression/expansion of the charge gas, and the blow-by of hot gases from the working gas volume. Cooling the charge gas in the crankcase **6502** increases the power and efficiency of the engine as well as the longevity of bearings used in the engine.

In one embodiment, an additional length of coolant tubing (shown as **6530** in FIG. 65B) is disposed inside the crankcase **6502** to absorb heat from the charge gas in the interior volume **6504**. The additional length of coolant tubing **6530** may include a set of extended heat transfer surfaces (shown as **6548** in FIG. 65B), such as fins, to provide additional heat transfer. As shown in FIG. 65B, the additional length of coolant tubing **6530** may be attached to the coolant tubing **6514** between the crankcase **6502** and the cooler **6520**. In an alternative embodiment, the length of coolant tubing **6530** may be a separate tube with its own feedthrough of the crankcase **6502** that is connected to the cooling loop by hoses outside of the crankcase **6502**.

In another embodiment the extended coolant tubing **6530** may be replaced with extended surfaces on the exterior surface of the cooler **6520** or the drive housing (shown as **6572** in FIGS. 65A and 65C). Alternatively, a fan (shown as **6534** in FIG. 65B) may be attached to the engine crankshaft (shown as **6542** in FIG. 65C) to circulate the charge gas in interior volume **6504**. The fan **6534** may be used separately or in conjunction with the

additional coolant tubing **6530** or the extended surfaces on the cooler **6520** or drive housing **6572** to directly cool the charge gas in the interior volume **6504**.

Preferably, coolant tubing **6514** is a continuous tube throughout the interior volume **6504** of the crankcase and the cooler **6520**. Alternatively, two pieces of tubing could be  
5 used between the crankcase and the feedthrough ports of the cooler. One tube carries coolant from outside the crankcase **6502** to the cooler **6520**. A second tube returns the coolant from the cooler **6520** to the exterior of the crankcase **6502**. In another embodiment, multiple pieces of tubing may be used between the crankcase **6502** and the cooler in order to add tubing with extended heat transfer surfaces inside the crankcase volume **6504** or to  
10 facilitate fabrication. The tubing joints and joints between the tubing and the cooler may be brazed, soldered, welded or mechanical joints.

Various methods may be used to join coolant tubing **6514** to cooler **6520**. Any known method for joining the coolant tubing **6514** to the cooler **6520** may be used in various embodiments. In one embodiment, the coolant tubing **6514** may be attached to the  
15 wall of the cooler **6520** by brazing, soldering or gluing. Cooler **6520** is in the form of a cylinder placed around the cylinder **6522** and the annular flow path of the working gas outside of the cylinder **6522**. Accordingly, the coolant tubing **6514** may be wrapped around the interior of the cooler cylinder wall and attached as mentioned above.

Alternative cooler configurations are presented in FIGS. 65D-65G that reduce the  
20 complexity of the cooler body fabrication. FIG. 65D shows one embodiment of a side view of a Stirling cycle engine including coolant tubing. In FIG. 65D, cooler **6552** includes a cooler working space **6550**. Coolant tubing **6548** is placed within the cooler working space **6550**, so that the working gas can flow over an outside surface of coolant tubing **6548**. The working gas is confined to flow past the coolant tubing **6548** by the cooler body **6552** and a  
25 cooler liner **6526**. The coolant tube passes into and out-of the working space **6550** through ports in either the cooler **6552** or the drive housing **6572** (shown in FIGS. 65A and 65C ). The cooler casting process is simplified by having a seal around coolant lines **6548**. In addition, placing the coolant line **6548** in the working space improves the heat transfer between the working fluid and the coolant fluid. The coolant tubing **6548** may be smooth or  
30 may have extended heat transfer surfaces or fins on the outside of the tubing to increase heat transfer between the working gas and the coolant tubing **6548**. In another embodiment, as shown in FIG. 65E, spacing elements **6554** may be added to the cooler working space **6550** to force the working gas to flow closer to the coolant tubes **6548**. The spacing elements are

separate from the cooler liner **6526** and the cooler body **6552** to allow insertion of the coolant tube and spacing elements into the working space.

In another embodiment, as shown in FIG. 65F, coolant tubing **6548** is overcast to form an annular heat sink **6556** where the working gas can flow on both sides of the cooler body **6552**. The annular heat sink **6556** may also include extended heat transfer surfaces on its inner and outer surfaces **6560**. The body of the cooler **6552** constrains the working gas to flow past the extended heat exchange surfaces on heat sink **6556**. The heat sink **6556** is typically a simpler part to fabricate than the cooler **6520** in FIGS. 65A and 65B. The annular heat sink **6556** provides roughly double the heat transfer area of cooler **6520** shown in FIGS. 65A and 65B. In another embodiment, as shown in FIG. 65G, the cooler liner **6526** can be cast over the coolant lines **6548**. The cooler body **6552** constrains the working gas to flow past the cooler liner **6562**. Cooler liner **6526** may also include extended heat exchange surfaces on a surface **6560** to increase heat transfer.

Returning to FIG. 65B, one method for joining coolant tubing **6514** to cooler **6520** is to overcast the cooler around the coolant tubing. This method is described, with reference to FIGS. 66A and 66B, and may be applied to a pressurized close-cycle machine as well as in other applications where it is advantageous to locate a cooler inside the crankcase.

Referring to FIG. 66A, a heat exchanger, for example, a cooler **6520** (shown in FIGS. 65A and 65B) may be fabricated by forming a high-temperature metal tubing **6602** into a desired shape. In one embodiment, the metal tubing **6602** is formed into a coil using copper. A lower temperature (relative to the melting temperature of the tubing) casting process is then used to overcast the tubing **6602** with a high thermal conductivity material to form a gas interface **6604** (and **6532** in FIG. 65B), seals **6606** (and **6524** in FIG. 65B) to the rest of the engine and a structure to mechanically connect the drive housing **6572** (shown in FIG. 2) to the heater head **6506** (shown in FIG. 65B). In one embodiment, the high thermal conductivity material used to overcast the tubing is aluminum. Overcasting the tubing **6602** with a high thermal conductivity metal assures a good thermal connection between the tubing and the heat transfer surfaces in contact with the working gas. A seal is created around the tubing **6602** where the tubing exits the open mold at **6610**. This method of fabricating a heat exchanger advantageously provides cooling passages in cast metal parts inexpensively.

FIG. 66B is a perspective view of a cooling assembly cast over the cooling coil of FIG. 66A. The casting process can include any of the following: die casting, investment casting, or sand casting. The tubing material is chosen from materials that will not melt or

collapse during the casting process. Tubing materials include, but are not limited to, copper, stainless steel, nickel, and super-alloys such as Inconel. The casting material is chosen among those that melt at a relatively low temperature compared to the tubing. Typical casting materials include aluminum and its various alloys, and zinc and its various alloys.

5           The heat exchanger may also include extended heat transfer surfaces to increase the interfacial area **6604** (and **6532** shown in FIG. 65B) between the hot working gas and the heat exchanger so as to improve heat transfer between the working gas and the coolant. Extended heat transfer surfaces may be created on the working gas side of the heat exchanger **6520** by machining extended surfaces on the inside surface (or gas interface)  
10 **6604**. Referring to FIG. 65B, a cooler liner **6526** (shown in FIG. 65B) may be pressed into the heat exchanger to form a gas barrier on the inner diameter of the heat exchanger. The cooler liner **6526** directs the flow of the working gas past the inner surface of the cooler.

The extended heat transfer surfaces can be created by any of the methods known in the art. In accordance some embodiments, longitudinal grooves **6704** are broached into the  
15 surface, as shown in detail in FIGS. 67A and 67C. Alternatively, lateral grooves **6708** (also shown in enlarged section view FIG. 67B-1) may be machined in addition to the longitudinal grooves **6704** (also shown in enlarged section view FIG. 67A-1) thereby creating aligned pins **6710** as shown in FIG. 67B. In some embodiments, grooves are cut at a helical angle to increase the heat exchange area.

20           In an alternative embodiment, the extended heat transfer surfaces on the gas interface **6604** (as shown in 66B) of the cooler are formed from metal foam, expanded metal or other materials with high specific surface area. For example, a cylinder of metal foam may be soldered to the inside surface of the cooler **6604**. As discussed above, a cooler liner **6526** (shown in FIG. 65B) may be pressed in to form a gas barrier on the inner diameter of  
25 the metal foam. Other methods of forming and attaching heat transfer surfaces to the body of the cooler are described in U.S. patent No. 6,694,731, issued Feb. 24, 2004, entitled Stirling Engine Thermal System Improvements, which is herein incorporated by reference in its entirety.

30           Additional coolant penetrating cold-end pressure vessel embodiments are described in U.S. Patent No. 7,325,399. It is to be understood that the various coolant penetrating cold-end pressure vessel embodiments referred to herein may be adapted to function in a multiple cylinder engine configuration.

### Intake Manifold

Referring now to FIGS. 68-69B, an intake manifold **6899**, is shown for application to a Stirling cycle engine or other combustion application in accordance with some embodiments. Various embodiments of intake manifold **6899** are further disclosed in U.S. Patent No. 6,381,958. In accordance with some embodiments, fuel is pre-mixed with air that may be heated above the fuel's auto-ignition temperature and a flame is prevented from forming until the fuel and air are well-mixed. FIG. 68 shows one embodiment including an intake manifold **6899** and a combustion chamber **6810**. The intake manifold **6899** has an axisymmetrical conduit **6801** with an inlet **6803** for receiving air **6800**. Air **6800** is pre-heated to a temperature, typically above 900 K, which may be above the auto-ignition temperature of the fuel. Conduit **6801** conveys air **6800** flowing inward radially with respect to combustion axis **6820** to a swirler **6802** disposed within the conduit **6801**.

FIG. 69A shows a cross sectional view of the conduit **6801** including swirler **6802** in accordance with some embodiments. In the embodiment of FIG. 69A, swirler **6802** has several spiral-shaped vanes **6902** for directing the flow of air **6800** radially inward and imparting a rotational component on the air. The diameter of the swirler section of the conduit decreases from the inlet **6904** to the outlet **6906** of swirler **6802** as defined by the length of the swirler section conduit **6801**. The decrease in diameter of swirler vanes **6902** increases the flow rate of air **6800** in substantially inverse proportion to the diameter. The flow rate is increased so that it is above the flame speed of the fuel. At outlet **6906** of swirler **6802**, fuel **6806**, which in a one embodiment is propane, is injected into the inwardly flowing air.

In some embodiments, fuel **6806** is injected by fuel injector **6804** through a series of nozzles **6900** as shown in FIG. 69B. More particularly, FIG. 69B shows a cross sectional view of conduit **6801** and includes the fuel jet nozzles **6900**. Each of the nozzles **6900** is positioned at the exit of the swirler vanes **6902** and is centralized between two adjacent vanes. Nozzles **6900** are positioned in this way for increasing the efficiency of mixing the air and fuel. Nozzles **6900** simultaneously inject the fuel **6806** across the air flow **6800**. Since the air flow is faster than the flame speed, a flame will not form at that point even though the temperature of the air and fuel mixture is above the fuel's auto-ignition temperature. In some embodiments, where propane is used, the preheat temperature, as governed by the temperature of the heater head, is approximately 900 K.

Referring again to FIG. 68, the air and fuel, now mixed, referred to hereafter as "air-fuel mixture" **6809**, is transitioned in direction through a throat **6808** which has a contoured

fairing **6822** and is attached to the outlet **6807** of the conduit **6801**. Fuel **6806** is supplied via fuel regulator **6824**.

Throat **6808** has an inner radius **6814** and an outer dimension **6816**. The transition of the air-fuel mixture is from a direction which is substantially transverse and radially inward with respect to combustion axis **6820** to a direction which is substantially parallel to the combustion axis. The contour of the fairing **6822** of throat **6808** has the shape of an inverted bell such that the cross sectional area of throat **6808** with respect to the combustion axis remains constant from the inlet **6811** of the throat to outlet **6812** of the throat. The contour is smooth without steps and maintains the flow speed from the outlet of the swirler to the outlet of the throat **6808** to avoid separation and the resulting recirculation along any of the surfaces. The constant cross sectional area allows the air and fuel to continue to mix without decreasing the flow speed and causing a pressure drop. A smooth and constant cross section produces an efficient swirler, where swirler efficiency refers to the fraction of static pressure drop across the swirler that is converted to swirling flow dynamic pressure. Swirl efficiencies of better than 80% may typically be achieved in practice. Thus, the parasitic power drain of the combustion air fan may be minimized.

Outlet **6812** of the throat flares outward allowing the air-fuel mixture **6809** to disperse into the chamber **6810** slowing the air-fuel mixture **6809** thereby localizing and containing the flame and causing a toroidal flame to form. The rotational momentum generated by the swirler **6802** produces a flame stabilizing ring vortex as well known in the art.

Referring to FIG. 70, a cross-section is shown of combustor **7022** and exhaust gas flow path **7013**, as described above in reference to earlier figures. In accordance with another embodiment it is recognized that the combustion exhaust gases remain above the temperature of combustion of the fuel well beyond the region of combustor **7022**, and that, since the fuel/air mixture is typically exceedingly lean, adequate oxidant remains for recombustion of the exhaust gases.

FIG. 70 further illustrates the use of a temperature sensor **7002**, typically a thermocouple, to monitor the temperature of heater head **7020** at the top of external pin array **7030** and thereby to control the fuel flow such as to maintain the temperature at sensor **7002** below a temperature at which the heater head significantly loses strength. The temperature at sensor **7002** is preferably maintained approximately 50.degree. C. below the melting temperature of the heater head material.

In the configuration depicted in FIG. 70, the use of a variable-cross-section gas flow bypass channel **7004** is illustrated, as described above. The taper of the bypass channel is greatly exaggerated for clarity of depiction. Even where a bypass channel is employed, the temperature profile as a function of distance from the top of the heater head is not flat, as would be preferable. Two additional temperature sensors, **7006** and **7008**, are shown at the middle and bottom, respectively, of external pin array **7030**, whereby the temperature of the exhaust gas may be monitored.

In accordance some embodiments, additional fuel is added to the exhaust gases at nozzle **7010** via afterburner fuel line **7012**. Nozzle **7010** may be a ring burner, circumferentially surrounding heater head **7020** and facing external pin array **7030** between the positions designated in FIG. 70 by temperature sensors **7002** and **7006**. The fuel flow through afterburner fuel line **7012** may be controlled on the basis of the exhaust gas temperature measured by temperature sensor **7008**. The precise position of temperature **7008** is preferably such as to measure the maximum temperature of the external pin array produced by the combustion of fuel exiting from afterburner nozzle **7010**.

Referring to FIG. 71A, a side view is shown in cross section of a burner and heat recovery system, designated generally by numeral **7100**, for a thermal cycle engine in accordance some embodiments. In the embodiment shown, heat is exchanged between hot exhaust gases, heated in combustor **7022**, and air drawn in at air inlet **7104** in a heat exchanger **7106** that is external to the heater head assembly. Additionally shown is fuel inlet **7108** and igniter **7110** used to initiate ignition in the combustor. Exhaust stream **7112** traverses heat transfer pins **7030** before being channeled to heat exchanger **7106**. A seal ring **7114** of copper, or other metal of sufficiently high melting temperature, forms a rod type seal on heater head flange **7116** just below the bottom row of heat transfer pins **7030**. Copper ring **7114** fits tightly on heater head flange **7116** producing a labyrinth seal. The right-hand portion of the cross-sectional view of FIG. 71A, showing the region of the seal, is shown, enlarged, in FIG. 71B. Copper seal ring **7114** fits tightly on heater head **7101** and has a close fit within annular groove **7118** on the bottom surface of burner cover **7120**. The configuration of ring **7114** in groove **7118** produces a labyrinth seal causing the exhaust gas, in exhaust plenum **7122** to travel a convoluted path around the back side of seal ring **7114** thereby limiting exhaust gas leakage. The tight fit of ring **7114** onto head **7101** limits exhaust gas leakage axially out of the burner.

It is to be understood that the various intake manifold embodiments described herein may be adapted to function in a multiple burner configuration.

### Gaseous Fuel Burner

Definitions: As used in this section of the detailed description, the following terms shall have the meanings indicated, unless the context otherwise requires: Fuel-Air Equivalence ratio ( $\phi$ )=Actual Fuel-Air Mass Ratio/Stoichiometric Fuel-Air Mass Ratio.

5 The stoichiometric fuel-air mass ratio is defined as the mass ratio needed to balance the fuel+air chemical equation. The stoichiometric fuel-air mass ratio is well known for common fuels such as propane (0.0638 g fuel/g air) and calculable for gases such as biogas.

FIG. 72 shows one embodiment of the engine **7212** embodiment having a gaseous fuel burner **7201**. Various embodiments of the gaseous fuel burner **7201** are also disclosed  
10 in U.S. Patent Application Ser. No. 11/122,447, filed May 5, 2005, published Nov. 10, 2005, which is herein incorporated by reference in its entirety. This embodiment may be used in the context of a Stirling cycle engine, however, other embodiments of the machine are not limited to such applications. Those skilled in the art will appreciate that the present machine may have application in other systems, such as, with other types of external  
15 combustion engines.

The use of an ejector in a gaseous fuel burner advantageously can solve some of the challenges faced by the traditional gaseous fuel burners. First, using an ejector can eliminate the need for additional equipment, controls, and space, such as, a gaseous fuel pump, fuel control circuitry, and the associated components. Furthermore, using an ejector such as a  
20 venturi simplifies the fuel control system by eliminating the need for a separate fuel control scheme. Based on the corresponding rise of the vacuum with the airflow, and subsequently, an increased fuel flow, the burner power can be regulated by regulating the airflow. Accordingly, removing separate fuel control simplifies the development and implementation of automatic burner control in a gaseous fuel burner with an ejector.

25 Secondly, the corresponding rise of the vacuum with airflow also results in an approximately steady fuel-air ratio despite changes in temperature and airflow rates. The resulting steady fuel-air ratio simplifies the fuel control and operation of the burner, by eliminating the need for complex exhaust sensor/feedback fuel control mechanisms.

Referring to FIG. 72, a gaseous fuel burner **7201** comprises an ejector **7240**, a heat  
30 exchanger **7220**, a combustion chamber **7250**, and a blower **7200** (shown as **7300** in FIG. 73A). The term ejector as used here includes eductors, siphons, or any device that can use the kinetic energy of one fluid to cause the flow of another fluid. Ejectors are a reliable way of producing vacuum-based fuel flow systems with low initial cost, lack of moving parts, and simplicity of operation.

Referring again to FIG. 72, in some embodiments, the ejector 7240 is a venturi. The venturi 7240 is positioned downstream of the outlet of the air preheater or heat exchanger 7220, in a venturi plenum 7241 and proximal to the combustion chamber 7250. A blower 7200 forces air through the venturi 7240. The flow of air through the venturi draws in a proportional amount of fuel through the fuel inlet ports 7279. The fuel inlet ports 7279 are placed at the venturi throat 7244 where the throat has the lowest pressure. The ports 7279 are sized to produce plumes of fuel across the airflow that promote good mixing within the venturi 7240. This fuel-air mixture exits the venturi 7240 and forms a swirl-stabilized flame in the combustion chamber 7250. The venturi 7240 draws in an amount of fuel that is substantially linearly proportional to the airflow regardless of airflow rates and temperature of the air entering the venturi 7240.

In some embodiments as shown in FIGS. 73A and 73B, placing the venturi 7340 between the air preheater 7320 and the combustion chamber 7350 promotes a substantially steady air-fuel ratio over a wide range of airflows and venturi temperatures. FIG. 73A is a schematic drawing of the burner including the components of the burner such as a blower 7300, a preheater 7320, a venturi 7340, and fuel supply 7372. The drawing also includes a load heat exchanger or heater head 7390 (also shown in FIGS. 76-78 as 7290). The load heat exchanger 7390 is the heat exchanger of the engine or process that absorbs the thermal power of the hot gases leaving the combustion chamber 7350 in the burner at some elevated temperature. The partially cooled burned gases then enter the exhaust side of the air preheater, where they are further cooled by incoming combustion air. FIG. 73B shows the pressure map of the same components arranged linearly. The air pressure supplied by the blower, the fuel supply pressure, and the ambient pressure are all indicated. The mass flow rate ( $m'$ ) of fuel into the burner is controlled by the difference between the fuel supply pressure at 7372 and the pressure in the venturi throat 7344 (shown in FIG. 72 as 7244) and the fuel temperature at the dominant restriction:

$$m'.sub.FUEL.varies.(P.sub.FUEL-P.sub.THROAT).sup.0.5/T.sub.FUEL.sup.0.5$$

The pressure in the throat ( $P.sub.THROAT$ ) is set by the pressure drop through the exhaust side of the preheater 7320 plus the pressure drop through the heater head tubes 7390 minus the suction generated by the venturi throat 7344. The pressure drops 7320, 7390 and the throat suction pressure 7344 are all proportional to the airflow rate and the venturi temperature.

$$P.sub.THROAT.varies.m'.sub.AIR.sup.2*T.sub.VENTURI$$

Combining these equations shows that the fuel flow will vary approximately linearly with the airflow:

$$m'_{\text{sub.FUEL}} \text{ varies } [P_{\text{sub.FUEL}} - (m'_{\text{sub.AIR}} \text{ sup. } 2 * T_{\text{sub.VENTURI}})] \text{ sup. } 0.5 / T_{\text{sub.FUEL}} \text{ sup. } 0.5$$

5           Regulating the fuel pressure to near ambient pressure, the fuel flow is approximately linear with airflow.

$$m'_{\text{sub.FUEL}} \text{ varies } m'_{\text{sub.AIR}} * (T_{\text{sub.VENTURI}} / T_{\text{sub.FUEL}}) \text{ sup. } 0.5$$

Thus, locating the dominant fuel restriction 7378 (shown as 7278 in FIG. 72) within the venturi plenum (shown as 7241 in FIG. 72) provides for an approximately steady fuel-air  
10 ratio over a wide range of airflow rates and venturi temperatures.

$$m'_{\text{sub.FUEL}} / m'_{\text{sub.AIR}} \text{ varies constant}$$

FIG. 74 shows one embodiment of the ejector such as the venturi. In this embodiment, the size of the opening of the venturi throat 7244 determines the amount of suction present at the throat 7244. In a specific embodiment, the venturi throat is  
15 approximately 0.24 inches in diameter. Referring back to FIGS. 72 and 74, fuel delivery means are coupled to the venturi 7240. The fuel delivery means may be manifolds, fuel lines or fuel tubes. The fuel delivery means may include other components such as a fuel restriction 7278, fuel inlet ports 7279 and fuel valves (not shown). Fuel supplied by a pressure regulator 7272 flows through a manifold 7273 and fuel inlet ports 7279 into the  
20 relatively lower pressure in the throat 7244. In one embodiment the fuel inlet ports 7279 provide the largest portion of the pressure drop in the fuel delivery means. Preferably, making the fuel inlet ports the largest restriction in the fuel delivery means assures that the restriction occurs at the venturi temperature and maximizes fuel-air mixing by producing the largest possible fuel plumes. Referring back to FIG. 72, the fuel and air flow into the  
25 divergent cone or diffuser 7248 of the venturi, where static pressure is recovered. In the diffuser 7248, the entrained fuel mixes with the air to form an ignitable fuel air mixture in the combustion chamber 7250. The ignitable fuel-air mixture then enters the combustion chamber 7250, where the igniter 7260 may ignite the mixture, and the tangential flow induced by a swirler 7230 creates a swirl-stabilized flame. Using an ejector 7240 to draw  
30 the gaseous fuel into the combustion chamber eliminates the need for a high-pressure gaseous fuel pump to deliver the fuel.

In one embodiment, the venturi 7240 is constructed from high temperature materials to withstand high temperatures and maintain its structural integrity. For the embodiment of FIG. 74, the dimensions of the venturi can be approximately 0.9 inches diameter inlet and

outlets with an approximately 0.24 inches diameter throat. The half angles of the convergent cone and divergent cones can be 21.degree. and 7.degree. respectively and the throat can be 0.25 inches long. In this embodiment, the venturi can be constructed from Inconel 600.

Alternatively, other high temperature metals could be used including, but not limited to  
5 Stainless Steels 310, 316L, 409 and 439, Hastalloy C76, Hastalloy X, Inconel 625 and other super alloys.

In one embodiment, as shown in FIG. 72, a swirler **7230** is located upstream of the venturi **7240** and advantageously creates a tangential flow of air through the venturi. As is well known in the art, the tangential flow from the swirler can create an annular vortex in  
10 the combustion chamber, which stabilizes the flame. Additionally, the swirler **7230** increases the suction pressure at the venturi throat **7244** by increasing the local air velocity over the fuel inlet ports **7279**. Adding the swirler allows the venturi throat **7244** to be made larger for a given suction pressure. Furthermore, the swirling action induced by the swirler **7230** can suppress fluctuations in the combustion chamber pressure from propagating  
15 upstream to the venturi **7240**. Such pressure fluctuations can temporarily slow or stop the flow of fuel gas into the venturi **7240**. The swirler **7230** thereby facilitates a steady fuel-air ratio in the combustion chamber for steady airflows. The swirler **7230** may be a radial swirler.

In other embodiments, the gaseous burner can be connected to multiple fuel sources.  
20 In this configuration, the burner may be fired, lit or ignited with a type of fuel and then run with a different type of fuel. The use of multiple fuel sources may require a fuel delivery means tuned for each fuel. FIGS. 75, 75A, and 75B show embodiments for two fuels with significantly different energy densities such propane and natural gas. In this embodiment, the fuel delivery means for the denser propane must be approximately three times more  
25 restrictive than the fuel delivery means for the less dense natural gas or methane. In the embodiment shown in FIG. 75, the venturi has different manifolds and fuel ports for each fuel. High-density fuels such as propane would require the more restrictive fuel inlet ports **7279**, while a low-density fuel such as natural gas would require less restrictive fuel inlet ports **7279A**. This configuration retains the highest resistance to fuel flow at the venturi  
30 temperature. However, the embodiment of the venturi in FIG. 75 may be more difficult to manufacture and have a higher-pressure loss drop due to the long narrow passage.

Another embodiment for a gaseous burner with multiple fuel sources is shown in FIG. 75A. In this embodiment, a fuel selector valve **7276** directs the fuel through an additional fuel restriction such as **7278A** or **7278B** for a dense gas or a less dense gas

respectively. The multi-port valve **7276** allows any number of predefined gases to be burned by the same burner. Predefined gases such as natural gas, liquid petroleum gas (LPG) or biogas can be burned in the same burner by simply setting a selector valve to the corresponding fuel setting. Alternatively, other embodiments can have multiple settings for different qualities of biogas as the carbon dioxide fraction in biogas can vary from 50% to 20%. The fuel restrictors may be placed outside the burner as shown in FIG. 75A or alternatively they can be located in the entrances to the manifold **7273**. If restrictions **7278** are placed outside of the burner, then significant part of the fuel-delivery-means pressure drop is not at the venturi temperature and thus the fuel-air ratio may vary with the venturi temperature. The burner will run initially leaner and get progressively richer as the hotter faster air flowing through the venturi exerts a stronger vacuum on the fuel. In addition, moving a significant part of the pressure drop from the fuel ports **7279**, the fuel will not penetrate as far into the air stream. Nevertheless, locating multiple restrictors **7278** for different gases may make the fabrication of the part easier.

An alternative embodiment, that provides significant flexibility in the fuel-air ratio control and fuel gas usages, is shown in FIG. 75B. In this embodiment, the two fuel sources, **7272A** and **7272B** are regulated to their individual pressure and flows through separate fuel delivery means adjusted for each fuel. Each fuel delivery means includes two or more restrictions in parallel **7206A** and **7208A**, and **7206B** and **7208B** with one or more valves **7202A**, and **7202B**, respectively, to vary the pressure drop of the fuel delivery means. The valves may be manually or automatically actuated. Fuel selector **7276** connects fuel delivery means to the venturi, while closing the other fuel off.

The multiple restrictions **7206A** and **7208A**, and **7206B** and **7208B** and the valves **7202A** and **7202B** allow the pressure drop of the fuel delivery means to be adjusted during burner warm-up. Thus the fuel-air ratio can be roughly maintained as the suction pressure increases with increasing venturi temperature. The multiple restrictions can also adjust for changing fuel gas density. A changing fuel gas density may occur when the gaseous fuel burner is connected to biogas digester, wherein the biogas digester is the source of fuel. In a biogas digester embodiment, the carbon dioxide (CO<sub>2</sub>) content and therefore the energy density can vary weekly. In this embodiment, if the CO<sub>2</sub> content increases, the pressure-drop through the fuel delivery means must be reduced to allow higher flows of the less energy dense fuel gas. In addition, the multiple restrictions can improve the ignition of the fuel gas by providing a richer fuel-air mixture for lighting. The richer mixture is provided by opening additional valves **7202A** or **7202B**, which also reduces the pressure-

drop of the fuel delivery means. Once the burner is lit, the valve **7202A** or **7202B** may be closed to produce a leaner flame. As described supra, once the burner is lit, the burner may be run on a different fuel. A fuel selector may be used to switch the fuel types.

Alternatively, an embodiment with a multiple fuel selector facilitates varying the fuel-air ratio during the operation of the burner.

Now referring to FIGS. 75A and 75B, the fuel selector **7276** may enable the burner to be lit on one fuel and run on a different type of fuel. This can be important if one fuel is too weak to ignite, but will burn in a warmed up burner. In one example, the burner may be lit on a higher density fuel such as propane. Once the burner is warmed up, the fuel selector **7276** is moved to draw in a low-density biogas.

FIG. 76 depicts an embodiment where an automated controller **7288** adjusts a variable restriction **7292** such as a variable flow valve in the fuel delivery means to hold the exhaust oxygen constant as measured by a wide-range lambda sensor or UEGO **7286**. In this embodiment, the automated scheme allows any fuel from biogas to propane to be connected to the burner and the control system can compensate for the changing fuel density. In this embodiment, the automated controller can restrict the fuel path for dense fuels such as propane and open up the fuel path for low-density fuels such as methane and biogas. Ignition would be accomplished by starting the variable restrictor **7292** in the fully open position, which will produce the richest mixture then closing it until the fuel-air mixture is ignited. After ignition, the controller can control the fuel flow to achieve the desired exhaust oxygen level. It is also envisioned that such an embodiment would allow the fuel air ratio to be adjusted during warm-up to optimize efficiency and burner stability.

In another embodiment as shown in FIG. 77, the gaseous fuel burner is a high efficiency burner for an external combustion engine such as a Stirling cycle engine. The burner includes manual controls to control the burner. The manual controls include a ball valve **7270** to manually select a fuel type, a trim valve **7274** to adjust the fuel-air ratio and a rheostat **7702** to control the blower speed, and subsequently the airflow. The preheated air **7222** in the venturi **7240** draws in the fuel from a fuel source **7272**. The fuel then mixes with the preheated air to create a fuel-air mixture. The fuel-air mixture flows into the combustion chamber **7250** where it burns. In this embodiment a microprocessor/controller **7288** holds the heater head temperature constant as measured by the temperature sensor **7289** by varying the engine speed. Furthermore, the blower-speed determines the burner power output and thus the engine power output. In an alternative embodiment, the fuel trim valve **7274** is not included.

Referring now to FIG. 78 the gaseous fuel burner **7201** is a high efficiency burner for an external combustion engine such as a Stirling cycle engine. In this embodiment, the burner includes an oxygen sensor **7286** located in the exhaust stream **7284** and a microprocessor/controller **7288** to automatically restrict the fuel flow with the variable restrictor **7292**. Additionally, the burner includes a blower controller (shown as **7702** in FIG. 77). The blower controller **7702** can be adjusted by the microprocessor/controller **7288** to match the Stirling engine power output with the load. In this embodiment, the burner temperature is held constant by varying the engine speed and the engine power output is automatically adjusted by setting the blower speed. Accordingly, in this embodiment, the burner can burn most gaseous fuels, including fuels without constant properties such as biogas.

In another embodiment as shown in FIG. 79, fuel is delivered directly into the venturi at a point proximal to the venturi throat **7244**. This embodiment includes a swirler **7230** to accommodate the fuel delivery means such as a fuel line or fuel tube. The swirler **7230** is preferably an axial swirler positioned in the venturi **7240** and upstream of the venturi throat **7244**. In operation, the delivered fuel is entrained with the motive air to form the fuel-air mixture. The exemplary manual or automatic control mechanisms are adaptable to this alternate fuel delivery embodiment.

Referring back to FIG. 74, the gaseous fuel burner further comprises an igniter **7260** and a flame-monitoring device **7210**. Preferably, the igniter **7260** is an excitable hot surface igniter that may reach temperatures greater than 1150.degree. C. Alternatively, the igniter **7260** may be a ceramic hot surface igniter or an excitable glow pin.

With continuing reference to FIG. 74, other embodiments include a flame-monitoring device **7210**. The flame-monitoring device **7210** provides a signal in the presence of a flame. For the safe operation of the any burner, it is important that the fuel be shut-off in the event of a flameout. The monitoring device for flame sensing is the flame rectification method using a control circuit and a flame rod.

Flame rectification, well known in the art, is one flame sensing approach for the small, high efficiency gas burners. The device uses a single flame rod to detect the flame. The flame rod is relatively smaller than the grounded heater head and it is positioned within the combustion flame. In this flame rectification embodiment, the control unit electronics are manufactured by Kidde-Fenwal, Inc., and the flame rod is commercially available from International Ceramics and Heating Systems

Preferably, the flame-monitoring device uses the hot surface igniter as the flame rod. Alternatively, the flame-monitoring device may be either remote from the hot surface igniter, or packaged with the igniter as a single unit.

Alternatively, an optical sensor may be used to detect the presence of a flame. A preferred sensor is an ultraviolet sensor with a clear view of the flame brush through an ultraviolet transparent glass and a sight tube.

It is to be understood that the various fuel burner embodiments described herein may be adapted to function in a multiple burner configuration.

### Fuel Pump

In accordance with some embodiments, a fuel flow to a pressurized combustion chamber of an engine, such as a Stirling engine, may be metered by varying the operating parameters of a fuel pump. Various embodiments of the fuel pump are described below and in U.S. Patent No. 7,111,460, issued Sep. 26, 2006, to *Jensen et al.*, and U.S. Patent Application Ser. No. 11/534,979, filed Sep. 25, 2006, published Feb. 8, 2007, which are herein incorporated by reference in their entireties. Desired performance may be achieved without the throttle plates or valves or other restrictive devices that are normally used to meter the fuel flow to the combustion chamber.

FIG. 80 shows a metering pump system providing gaseous fuel to a pressurized combustion chamber **8058** of an engine **8022** according to one embodiment. A gas train, labeled generally as **8005**, includes a fuel pump **8014**, interconnecting lines **8038**, **8042** and may include a pressure regulator **8018**. The fuel pump **8014** raises the fuel pressure in line **8038** to a higher pressure in line **8042**. The gas train delivers fuel from the gas supply to the burner **8010**, where it is mixed with air and burned in a combustion chamber **8058**. The fuel pump is controlled by a controller **8034** that modulates the fuel flow rate by varying one or more parameters of an electrical signal sent to the fuel pump **8014**. The controller may also regulate a blower **8060** that provides air to the combustion chamber **8058** and may receive signals from sensors that report engine-operating parameters.

In some embodiments the delivered fuel pressure in line **8038** is 6 to 13 inches water column for liquefied petroleum gas. Natural gas may be supplied in line **8038** at even lower pressures of 3 to 8 inches water column. Alternatively, pressure regulator **8018** can supply the fuel at lower pressures, even negative pressures. Typical fuel pressures in line **8042** may range from 0.5 to 5 PSIG.

In some embodiments, fuel pump **8014** is a linear piston pump. A linear piston pump is shown in FIG. 81. The pump includes a cylinder **8100**, a piston **8102**, a winding **8104**, a

spring **8106** and check valves **8108**, **8112**. When an electrical signal is applied to winding **8104**, the winding pulls the ferrous metal piston **8102** to the left, compressing the spring **8106**. Check valve **8108** in the piston allows fuel to flow into compression volume **8110**. When the electrical signal is turned off and the electromagnetic force on the piston begins to decrease, the piston **8102** is forced to the right by the spring **8106**. Gas is forced out check valve **8112** into the receiver volume **8114** at a higher pressure.

The flow rate of the pump can be modulated by varying the stroke of the piston **8102**. In one embodiment the signal from the controller to the pump is a half-wave alternating current ("AC") signal, as shown in FIG. 82. Circuitry to produce this signal is well known in the art. The piston stroke and, thus, the flow rate increases as the amplitude of the AC signal increases. In some embodiments, low amplitude signals are biased slightly higher to improve repeatability and linearity of flow versus the driving signal. The force applied to the piston **8102** by the windings **8104** is inversely proportional to the distance from the windings to the piston. At low signal levels, the piston does not get very close to the windings and small changes in the friction and inertia of the piston will produce significant changes in the resulting piston stroke and flow. A bias voltage is applied to bring the resting-position of the piston closer to the windings, so that small changes in the controller signal that drives the piston dominate the frictional forces and the inertia of the piston. For example, the bias voltage added to the signal is highest at the lowest driving signal (10% signal in FIG. 82) and may drop to zero before the drive signal reaches 50%. The bias is reduced at higher flow levels to take advantage of the full pump stroke.

In another embodiment, the controller signal that drives the pump is a pulse-width-modulated ("PWM") direct current ("DC") voltage signal. FIG. 83 shows an exemplary DC waveform that may be used to drive the pump. Circuitry to generate the PWM DC signal in FIG. 83 is well known in the art. Three different drive signals are plotted versus time. These signal modulations correspond to 10%, 50% and 90% duty cycles, which are shown for purposes of illustration and not for limitation. Applying the rectangular wave voltages of FIG. 83 to the windings **8104** of FIG. 81 will cause the piston **8102** to move to the left and compress the spring **8106**. The stroke and, therefore, the flow will be roughly proportional to the voltage times the duration of the signal. The lower signals, 10% and 50%, include bias voltages between signal pulses. As in the case of the AC drive signal, the bias voltage moves the piston closer to the windings to provide greater piston response to small changes in the signal and overcome the frictional and inertia forces of the piston. This bias voltage may be varied with the duration of the drive signal. The bias voltage is highest at the

minimum drive signal duration and may drop to zero before the drive voltage pulse duty cycle reaches 50%.

Other embodiments may use different controller signal waveforms to drive the piston. In another embodiment, the piston pump of FIG. 81 can be driven without the bias  
5 voltages shown in FIGS. 82 and 83.

In another embodiment both the frequency and the duration of the PWM DC controller signal modulating the pump can be varied to linearize the flow through the pump with changes in the driving signal.

In further embodiments, pump **8014** is a diaphragm pump as shown in FIG. 84. In  
10 the diaphragm pump, one or more solenoidal coils **8200** drive the shaft of the pump **8202** back and forth. The shaft **8202** deflects two diaphragms **8204** that alternatively pull gas into the chambers **8212** and then expel it. The two wire coil is driven with an AC signal connected to wires (**8234**, **8236**) that drives the piston **8202** back and forth by reversing the flow of current through the coil **8200**. The solenoid has a permanent magnet so that a  
15 reversing magnetic field can drive the solenoid in opposite directions. The pumping force on the two chambers **8212** is phased 180 degrees apart so that as one chamber is filled, the companion chamber is emptied. Check valves **8208** upstream of the pumping chambers **8212** allow gas flow in, while the downstream valves **8210** allow flow out of the chambers and into the receiver volume **8216**. The solenoidal coil **8200** can be driven with a full wave  
20 AC signal. In similar fashion to the piston pump, varying the amplitude of the AC signal will vary the stroke and, therefore, the fuel flow through the diaphragm pump.

In another embodiment, the electrical coil **8200** in the diaphragm pump **8014** of FIG. 84 can be center-tapped by adding a third wire **8232** to the center of the coil **8200**. Wires (**8234** and **8236**) connect to each end of the coil. This three wire connection allows the  
25 piston **8202** to be driven back and forth with a DC source. The DC source connects to the center wire **8232** and the other connecting wires (**8234** and **8236**) are alternately connected to ground or a negative voltage, causing current to flow in one half-coil or the other.

A three-wire coil **8302** and devices (**8304**, **8306**, **8308**) to control the DC current flow to the coil are shown schematically in FIG. 85. The coil may be used to drive a  
30 diaphragm pump solenoid, as in FIG. 85. Devices (**8304**, **8306**, **8308**) may be relays, field effect transistors ("FET"), bipolar transistors or other similar devices. The controller can vary the flow of fuel through the diaphragm pump by varying the amplitude of applied DC voltage signal **8312** using device **8304**. Devices **8306**, **8308** can be driven as shown in FIG. 86A, where first one device is closed, then opened and then the other device is closed and

then opened. The vertical axis of the figure corresponds to a normalized driving voltage, where a signal equal to "1" means a device is closed (i.e., shorted). Control strategies using PWM signals, as illustrated in FIG. 83, albeit without the bias described previously for the piston pump and with suitable phasing, can be applied to each of devices **8306**, **8308** in FIG. 5 85.

In another embodiment the amplitude and frequency of the diaphragm pump stroke of FIG. 84 can be controlled using the three devices (**8302**, **8304**, **8306**) shown in FIG. 85. The amplitude of the pump stroke is controlled by the average voltage at wire **8312**. This voltage can be modulated by fast pulse-width-modulating device **8304**. The stroke 10 frequency may be controlled as before by devices **8306** and **8308**. Alternatively, device **8304** can be eliminated and switches **8306** and **8308** can be pulse-width modulated at a high frequency during their "on" state, as illustrated in FIG. 86B. In other embodiments the center-tapped coil can be replaced by a full bridge or a half-bridge, as known to those skilled in the art.

In other embodiments for use in applications where a constant flow of fuel is 15 important, a filter **8701** may be added between pump **8700** and burner head **8706**, where the fuel is mixed with the combustion air, as shown in FIG. 87A. One embodiment of the filter **8701** is an RC filter comprising a capacitance (volume) **8702** and an orifice **8704**. The volume and orifice are sized to allow the required fuel flow and reduce fluctuations in flow 20 to a desired level. Mathematical techniques that are well known in the art may be used to determine these filter parameters.

An acoustic filter using a volume and an orifice restrictor has the electrical circuit analog shown in FIG. 87B. The analog of gas flow is electrical current, the analog of gas pressure is electrical voltage, the analog of volume is electrical capacitance, the analog of 25 flow resistance is electrical resistance and the analog of gas inertia is electrical inductance. The orifice restrictor does not translate directly into this model because the orifice flow resistance is proportional to the gas flow squared (non-linear) instead of being proportional to the gas flow as the model suggests. The model can be used through the process of linearization of flow resistance for small signals. The pump gas flow ripple is attenuated by 30 the factor of  $1/(1+2\pi fRC)$ . Where "f" is the frequency component of the gas flow entering the filter from the pump. Due to the orifice restrictor non-linear characteristics, the acoustic filter has a lower attenuation at low flow causing a high burner flow ripple as a percentage of average flow. The higher ripple can cause flame instability and higher emissions of

pollutants. This non-linearity also causes a high resistance to average gas flow at the higher flow rates reducing the pump maximum flow capability.

The addition of a long thin tube **8703** to the acoustic filter provides ripple attenuation through the gas mass acceleration, as shown in FIG. 87C. The diagram for the electrical analog is shown in FIG. 87D. The pump gas flow ripple is attenuated by the factor of  $1/[1+(LC)(2\pi f)^2]$ . Since L and C are not a function of flow, the filter attenuation is not affected by the flow rate and does not have the disadvantages of the filter of FIG. 87A. Attenuation of the ripple also increases the pump's flow rate.

Referring again to FIG. 80, in another embodiment, controller **8034** modulates the output of the fuel pump **8014** to control the temperature of the heater tubes **8026** of the engine. The temperature of the heater tube **8026** may be measured with a temperature sensor **8054**, such as a thermocouple, that is attached to a heater tube **8026**. When the engine increases speed, the engine draws more thermal energy from the heater tubes **8026**. The tubes cool and the thermocouple **8054** reports this temperature drop to the controller **8034**, which in turn increases the fuel flow until the measured temperature is restored to a specified level. Any of the devices and methods for metering the fuel through the fuel pump, as described above, may be employed in this embodiment of the machine. Various fuel pump types including rotary vane pumps, piezoelectric pumps, crank driven piston pumps, etc., may be employed. In other embodiments, various operating parameters of a system, of which the pressurized chamber is a part, may be controlled by controlling the fuel pump to meter the fuel flow to the chamber. For example, the speed of an internal combustion engine or the power output of an engine may be determined by the controller. Alternatively, a fuel/air mixture ratio to a burner may be maintained by the controller.

It is to be understood that the various fuel pump embodiments described herein may be adapted to function in a multiple burner configuration.

#### **Single Burner Multiple Piston Engine**

Referring now to FIGS. 88, 89A-89C, various embodiments is shown wherein an engine **8800**, such as a Stirling cycle engine, having a rocking beam drive **8802** (also shown as **810** and **812** in FIG. 8) and a plurality of pistons (also shown in FIG. 8 as **802**, **804**, **806**, and **808**), includes a single burner (shown as **8900** in FIGS. 89A and 89B) to heat heater heads **8804** of the pistons. Heater heads **8804** may be one of the various embodiments disclosed in the preceding section, including, but not limited to, tube heater heads, as designated by numeral **8902** in FIG. 89A (also shown as **9116** in FIGS. 91C and 91D), or pin or fin heater heads, as designated by numeral **8904** in FIG. 89C (and also shown as **5100**

in FIGS. 53D through 53F). FIG. 89B included a pin heater head **8904** having a heater head lining **8926** fitted around the heater head **8904**. Burner **8900** may be one of any of the various embodiments disclosed in the preceding sections and in U.S. Patent No. 6,971,235, issued Dec. 6, 2005, to *Langenfeld et al.*, which is herein incorporated by reference in its entirety.

In one embodiment a combustion chamber **8906** is positioned above the heater heads **8900**, as shown in FIGS. 89A – 89C. A prechamber **8901** may connect the combustion chamber **8906** to a burner head **8903** via a prechamber nozzle **8908**, wherein prechamber nozzle **502** may be a simple nozzle, a swirler nozzle, or a pressure swirl nozzle. The burner head **8903** may house a UV window **8910** for flame detection, a fuel injector **8912**, which may be an air-assist fuel injector such as a Delevan siphon nozzle, and a hot surface igniter **8914**. Also connected to the burner head **8903** are a first inlet **8916** and a second inlet **8918**. One of these inlets may be a liquid fuel inlet, and the other inlet may be an atomizing inlet.

The prechamber **8901** is a centrally located fuel preparation stage located upstream from the combustion chamber **8906**. The prechamber **8901** is where the fuel is ignited to form a diffusion flame. In one embodiment where liquid fuel is used, the liquid fuel passes through the first inlet **8916**. Atomizer passes through the second inlet **8918** to atomize the liquid fuel and mix with the liquid fuel in the prechamber **8901**. As the atomizer and liquid fuel enter the prechamber **8901** via fuel injector **8912**, it is ignited by the hot surface igniter **8914**. Air may also pass through an intake **8920** and be preheated by a preheater **8922** before it travels into the prechamber **8901**, where it will mix with the atomizer and the liquid fuel. Once the mixture is preheated and formed into a diffusion flame, it travels through the prechamber nozzle **8908** into the combustion chamber **8906** to form a PPV (premixed prevaporized) flame. When the diffusion flame leaves the prechamber **8901**, evaporation may occur in the prechamber **8901** which may allow the diffusion flame to be relit more easily, should it get flamed out or burned out.

Once the flame is in the combustion chamber **8901**, the heat from the flame is used to heat the heater heads **8804**. The heated gas from the combustion chamber **8901** evenly flows over the surface of each of the heater heads **8804**, wherein heater heads **8804** transfer the heat contained in the heated gas to a working fluid contained in the working space (shown as **8806** in FIG. 88) of the engine (shown as **8800** in FIG. 88). The combustion chamber **8901** may have apertures **8924** in its surface to further assist in distributing the PPV flame evenly across each of the heater heads **8804**.

As described above in the current and preceding sections, the heater heads **8804** may be a pin heater head, a folded fin heater head, or may be heater tubes. In an embodiment using a pin or fin heater head, the heater head may include a heater head lining **8926** as shown in FIG. 89B (and also shown as **5340** in FIG. 53A). The heater head lining **8926** may be a sleeve that is fitted around the heater head **8904** or it may be a sleeve that is heated and expanded and then fit around the heater head such that when the sleeve cools it contracts and creates a snug fit around the heater head. The heater head lining **8926** ensures uniform flow of the heated gas. Uniform flow prevents uneven temperature distribution around the heater heads **8804** and ensures thermal efficiency, as discussed in detail in the preceding sections. Resultant exhaust from the burner may exit the burner through an exhaust **8928**.

Because the burner may reach very high temperatures, the metal sued to form the burner may expand. Expansion of certain burner surfaces **8930** may interfere with the efficiency of the engine or may damage the heater heads **8804**. In an alternative embodiment a compliant member may be positioned between the heater heads **8804**, or, should it be used, the heater head lining **8926** and the burner surface **8930**. The compliant member acts as a buffer against the expanding metal burner surface **8930** so that the burner surface **8930** does not expand into the heater heads **8804**.

In an alternative embodiment a gaseous fuel, such as propane may be used. In such an embodiment the burner may include a burner head **8903** and a combustion chamber **8906**. The burner head **8903** may house the UV window **8910** for flame detection, a fuel injector **8912**, which may be an air-assist fuel injector such as a Delevan siphon nozzle, and a hot surface igniter **8914**. The gaseous fuel may enter the combustion chamber **8906** via the fuel injector **8912**. Upon exiting the fuel injector **8912**, the gaseous fuel would be ignited by the hot surface igniter **8914**, thereby creating a flame inside the combustion chamber **8906**. Combustion of gaseous fuels is described in detail in the preceding sections.

In yet another embodiment burner **8900** may use both gaseous and liquid fuels. Similar to the exemplary embodiment described earlier, and various other embodiments described in preceding sections, the burner **8900** would include a combustion chamber **8906**, a prechamber **8901**, and a burner head **8903**. The combustion chamber **8906** may be positioned above the heater heads **8804**. A prechamber **8901** may connect the combustion chamber **8906** to a burner head **8903** via a prechamber nozzle **8908**, wherein prechamber nozzle **8908** may be a simple nozzle, a swirler nozzle, or a pressure swirl nozzle. The burner head **8903** may house a UV window **8910** for flame detection, a fuel injector **8912**, which may be an air-assist fuel injector such as a Delevan siphon nozzle, and a hot surface igniter

**8914.** Also connected to the burner head **8903** are a first inlet **8916** and a second inlet **8918**. One of these inlets may be a liquid fuel inlet and the other inlet may be an atomizing inlet. A switch may be positioned between the first inlet **8916** and the second inlet **8918** so that when gaseous fuel is used, the gaseous fuel would flow through the second inlet **8918**,  
5 instead of the atomizer as described above. When liquid fuel is used, the switch would be configured such that liquid fuel would flow through the first inlet **8916** and atomizer would flow through the second inlet **8918**.

In a further embodiment of the burner, a blower may be coupled to burner **8900**.

#### **Multiple Burner Multiple Piston Engine**

10 Referring now to FIGS. 90 through 91B, another embodiment is shown wherein each heater head **9002** of engine **9000** may be heated by an individual burner **9004**, as shown in FIG. 90. Heater heads **9002** may be any of the various embodiments described in the preceding sections, including, but not limited to, tube heater heads, as designated by numeral **9116** in FIGS. 91B-91D, or pin or fin heater heads, as designated by numeral **9118**  
15 in FIG. 91A (and also shown as **5100** in FIGS. 53D through 53F). Burner **9004** may be any one of the various embodiments disclosed in the preceding sections and in U.S. Patent No. 6,971,235.

Each burner **9004** includes a burner head **9100**. Similar to previous disclosed burner embodiments, the burner head **9100** has an igniter **9101**, a fuel injector **9108**, and a UV  
20 window (shown as **9107** in FIG. 91B) for flame detection. Fuel passes through a first inlet **9106**, where it is heated by the igniter **9101** and formed into a flame. Preheated air, heated by the preheater **9102**, may be mixed with the fuel in the combustion chamber **9103**. The heated fuel mixture forms a flame inside the combustion chamber **9103** and heats the heater head **9002**. Any exhaust from the burner may exit the burner via an exhaust **9105**. In an  
25 alternative embodiment of the burner, an atomizer may be combined with the fuel via a second inlet **9110**. In another embodiment of the burner, a blower may be incorporated to maintain an average air ration amongst the individual burners **9004**.

Yet another embodiment may include a prechamber **9111**, as shown in FIG. 91B. In this embodiment, the burner may include a combustion chamber **9103**, a prechamber **9111**,  
30 and a burner head **9100**. Combustion chambers **9103** may be positioned above the heater heads **9002**. A prechamber **9111** may connect the combustion chamber **9103** to a burner head **9100** via a prechamber nozzle **9112**, such as a simple nozzle, a swirler nozzle, or a pressure swirl nozzle. The burner head **9100** may house the UV window **9107** for flame detection, a fuel injection **9108**, which may be an air-assist fuel injector such as a Delevan

siphon nozzle, and a hot surface igniter **9101**. Also connected to the burner head **9100** are a first inlet **9106** and a second inlet **9110**. One of these inlets may be a liquid fuel inlet and the other inlet may be an atomizing inlet.

The prechamber **9111** is a centrally located fuel preparation stage located upstream  
5 from the combustion chamber **9103**. The prechamber **9111** is where the fuel is ignited to form a diffusion flame. In one embodiment, where liquid fuel is used, the liquid fuel passes through the first inlet **9106**. Atomizer passes through the second inlet **9110** to atomize the liquid fuel and mix with the liquid fuel in the prechamber **9111**. As the atomizer and liquid fuel enter the prechamber **9111** via fuel injector **9108**, it is ignited by the hot surface igniter  
10 **9101**. Air may also pass through an intake and be preheated by a preheater **9102** before it travels into the prechamber **9111**, where it will mix with the atomizer and the liquid fuel. Once the mixture is preheated and formed into a diffusion flame, it travels through the prechamber nozzle **9112** into the combustion chamber **9103** to form a PPV (premixed prevaporized) flame. When the diffusion flame leaves the prechamber **9111**, evaporation  
15 may occur in the prechamber **9111** which may allow the diffusion flame to be relit more easily, should it get flamed out or burned out.

Once the flame is in the combustion chamber **9103**, the heat from the flame is used to heat the heater heads **9002**. The heated gas from the combustion chamber **9103** evenly flows over the surface of each of the heater heads **9002**, wherein heater heads **9002** transfer  
20 the heat contained in the heated gas to a working fluid contained in the working space of the engine (shown as **9000** in FIG. 90). The combustion chamber **9103** may have apertures (shown as **9114** in FIG. 91A) in its surface to further assist in distributing the PPV flame evenly across each of the heater heads **8804**.

The principles of the present invention may be applied to all types of engines,  
25 include Stirling engines, and may be applied to other piston machines utilizing cylinders such as internal combustion engines, compressors, and refrigerators. However, the present invention may not be limited to the double-acting four-cylinder Stirling engine.

While the principles of the invention have been described herein, it is to be understood by those skilled in the art that this description is made only by way of example  
30 and not as a limitation as to the scope of the invention. Other embodiments are contemplated within the scope of the present invention in addition to the exemplary embodiments shown and described herein. Modifications and substitutions by one of ordinary skill in the art are considered to be within the scope of the present invention.

## CLAIMS

What is claimed is:

1. A rocking beam drive mechanism for a machine comprising:
  - a rocking beam having a rocker pivot;
  - at least one cylinder;
  - at least one piston, the piston housed within a respective cylinder whereby the piston is capable of substantially linearly reciprocating within the respective cylinder;
  - and
    - at least one coupling assembly having a proximal end and a distal end, the proximal end being connected to the piston and the distal end being connected to the rocking beam by an end pivot, whereby linear motion of the piston is converted to rotary motion of the rocking beam.
2. The rocking beam drive mechanism of claim 1 wherein the rocking beam is coupled to a crankshaft by way of a connecting rod and whereby the rotary motion of the rocking beam is transferred to the crankshaft.
3. The rocking beam drive mechanism of claim 1 wherein the cylinder further comprising a closed end and an open end, wherein the open end further comprising a linear bearing connected to the cylinder, the linear bearing having an opening to accommodate the coupling assembly.
4. The rocking beam drive mechanism of claim 3 wherein the coupling assembly further comprising:
  - a piston rod; and
  - a link rod, the piston rod and link rod coupled together by a coupling means, the coupling means being located beneath the linear bearing.
5. The rocking beam drive mechanism of claim 4 further comprising a seal, the seal being sealably connected to the piston rod.
6. The rocking beam drive mechanism of claim 5 wherein the seal is a rolling diaphragm.

7. The rocking beam drive mechanism of claim 4 wherein the coupling means is a flexible joint.

8. The rocking beam drive mechanism of claim 4 wherein the coupling means is a roller bearing.

9. The rocking beam drive mechanism of claim 4 wherein the coupling means is a hinge.

10. The rocking beam drive mechanism of claim 4 wherein the coupling means is a flexure.

11. The rocking beam drive mechanism of claim 4 wherein the coupling means is a journal bearing joint.

12. A Stirling cycle machine comprising:

at least one rocking drive mechanism comprising:

a rocking beam having a rocker pivot;

at least one cylinder;

at least one piston, the piston housed within a respective cylinder

whereby the piston is capable of substantially linearly reciprocating within the respective cylinder; and

at least one coupling assembly having a proximal end and a distal end, the proximal end being connected to the piston and the distal end being connected to the rocking beam by an end pivot, whereby linear motion of the piston is converted to rotary motion of the rocking beam;

a crankcase housing the rocking beam and housing a first portion of the coupling assembly;

a crankshaft coupled to the rocking beam by way of a connecting rod, whereby the rotary motion of the rocking beam is transferred to the crankshaft;

a working space housing the at least one cylinder, the at least one piston and a second portion of the coupling assembly; and

a seal for sealing the workspace from the crankcase.

13. The Stirling cycle machine of claim 12 wherein the seal is a rolling diaphragm.
14. The Stirling cycle machine of claim 12 wherein the coupling assembly further comprising:
  - a piston rod; and
  - a link rod, the piston rod and link rod coupled together by a coupling means.
15. The Stirling cycle machine of claim 12 further comprising a lubricating fluid pump in the crankcase.
16. The Stirling cycle machine of claim 15 wherein the lubricating fluid pump is a mechanical lubricating fluid pump driven by a pump drive assembly, the pump drive assembly being connected to and driven by the crankshaft.
17. The Stirling cycle machine of claim 15 wherein the lubricating fluid pump is an electric lubricating fluid pump.
18. The Stirling cycle machine of claim 13 further comprising a motor connected to the crankshaft.
19. The Stirling cycle machine of claim 13 further comprising a generator connected to the crankshaft.
20. A Stirling cycle machine comprising:
  - at least two rocking drive mechanisms comprising:
    - a rocking beam having a rocker pivot;
    - two cylinders;
    - two pistons, the pistons each housed within a respective cylinderwhereby the pistons are capable of substantially linearly reciprocating within the respective cylinder; and
    - two coupling assemblies having a proximal end and a distal end, the proximal end being connected to the piston and the distal end being connected to the rocking beam by an end pivot, whereby linear motion of the piston is converted to rotary motion of the rocking beam;

a crankcase housing the rocking beam and housing a first portion of the coupling assemblies;

a crankshaft coupled to the rocking beam by way of a connecting rod, whereby the rotary motion of the rocking beam is transferred to the crankshaft;

a lubricating fluid pump in the crankcase for pumping lubricating fluid to lubricate the crankshaft and the rocking beam and the first portion of the coupling assemblies;

a working space housing the cylinders, the pistons and the second portion of the coupling assemblies; and

a rolling diaphragm for sealing the workspace from the crankcase.

21. The Stirling cycle machine of claim 20 wherein the coupling assemblies further comprising:

a piston rod; and

a link rod, the piston rod and link rod coupled together by a coupling means.

22. The Stirling cycle machine of claim 20 wherein the coupling means is a flexible joint.

23. The Stirling cycle machine of claim 20 wherein the coupling means is a roller bearing.

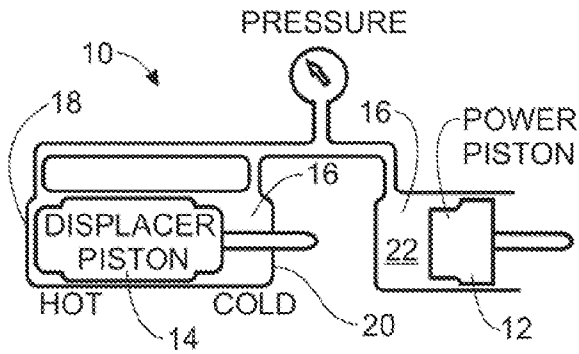

READY FOR START OF COMPRESSION STROKE

FIG. 1A  
PRIOR ART

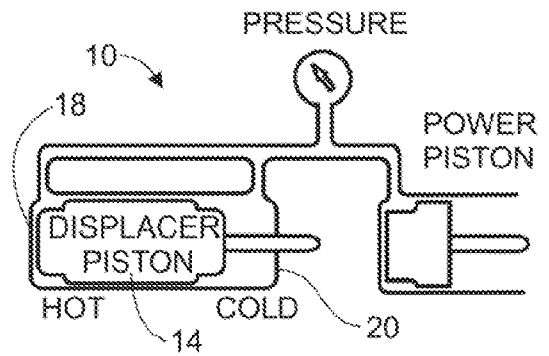

END OF COMPRESSION STROKE

FIG. 1B  
PRIOR ART

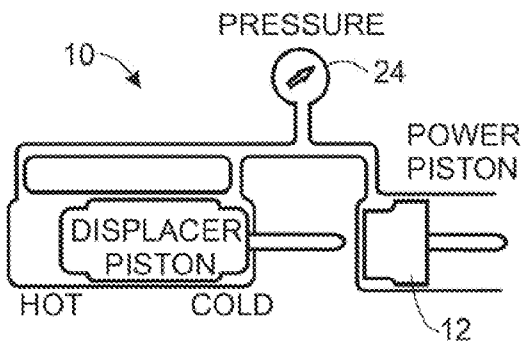

READY FOR START OF EXPANSION STROKE

FIG. 1C  
PRIOR ART

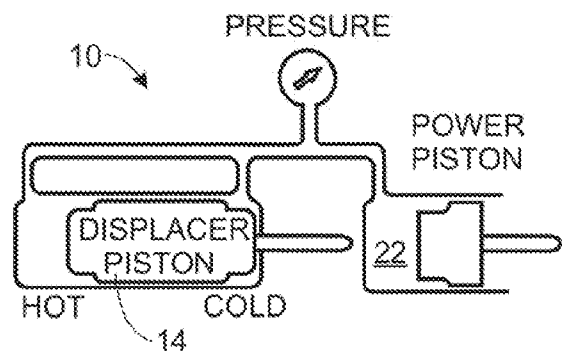

END OF EXPANSION STROKE

FIG. 1D  
PRIOR ART

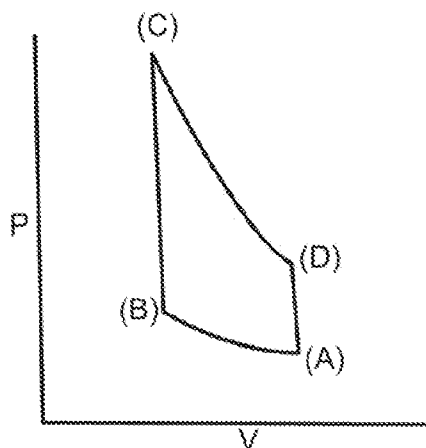

FIG. 1E  
PRIOR ART

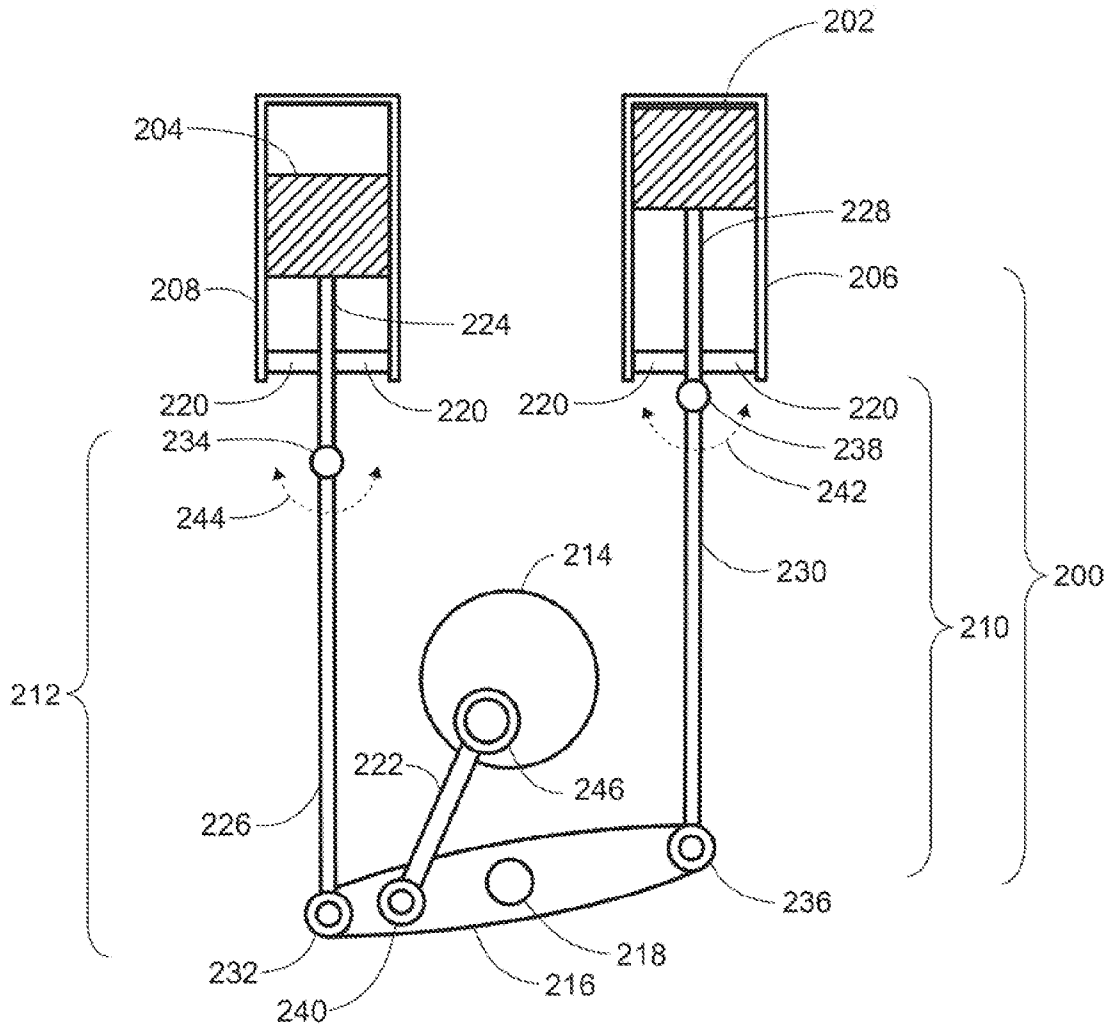

FIG.2

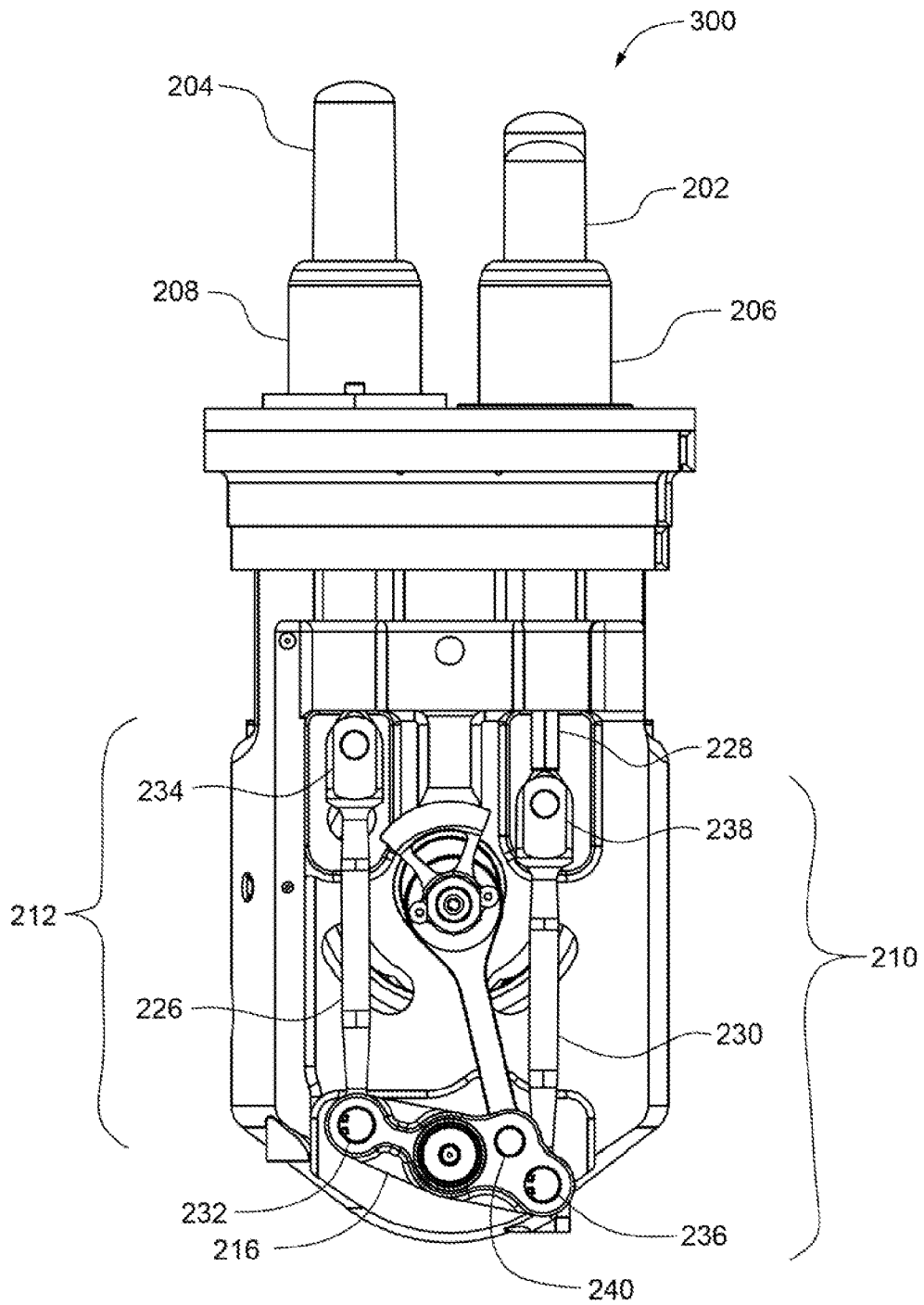

FIG. 3

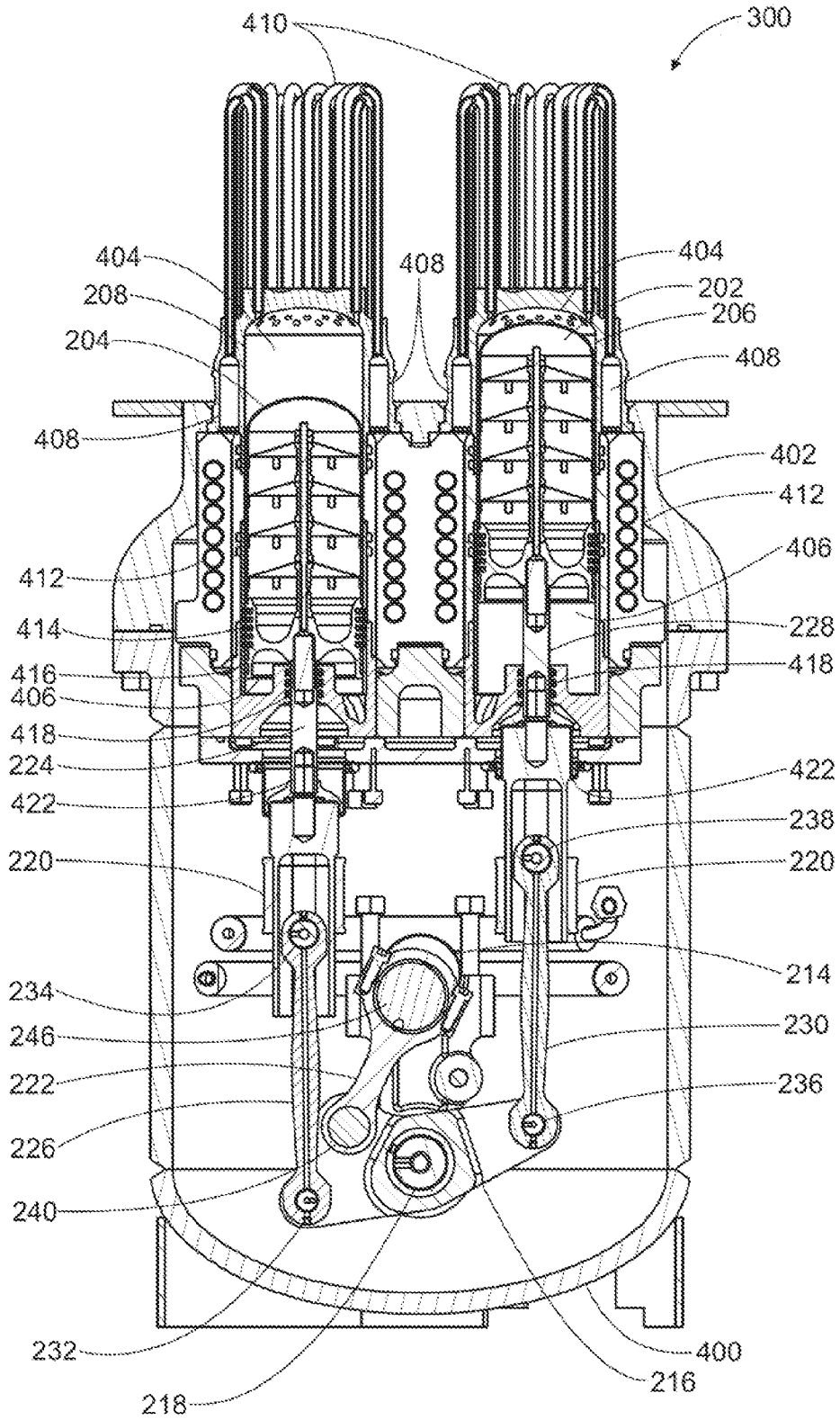

FIG. 4

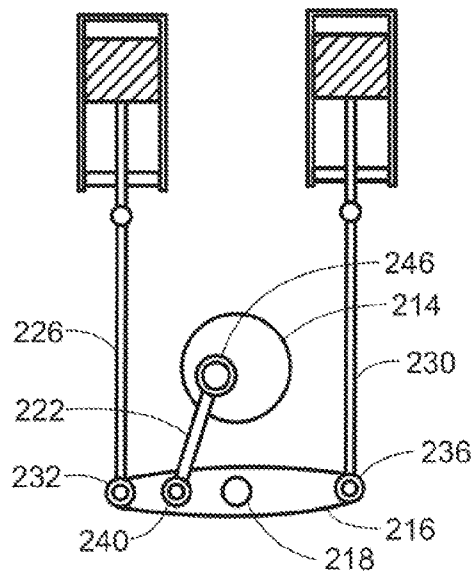

FIG. 5A

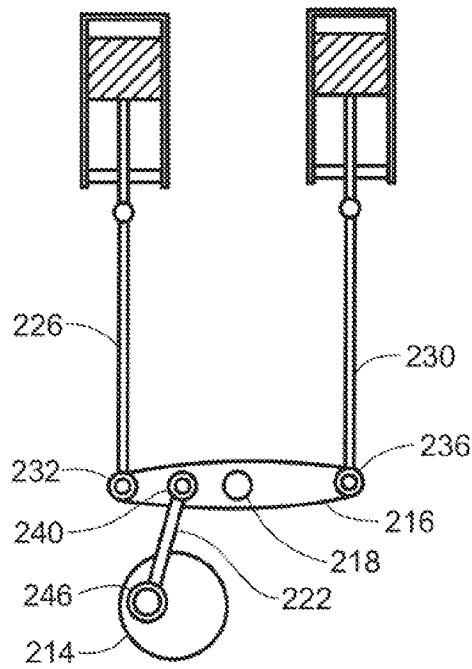

FIG. 5B

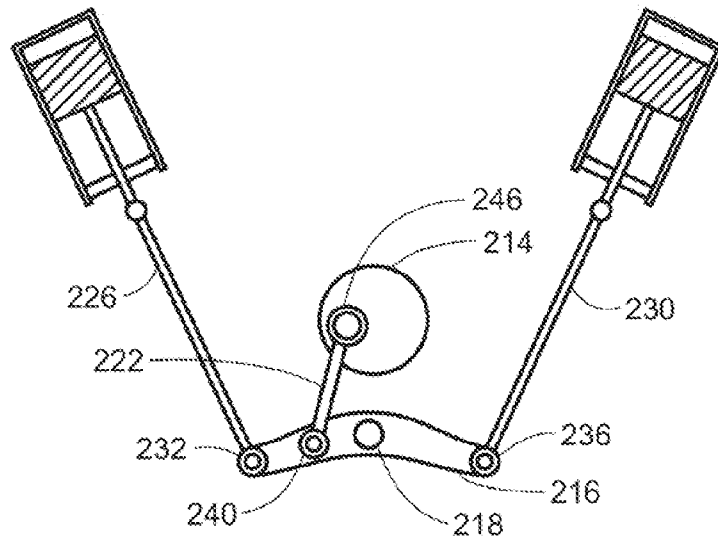

FIG. 5C

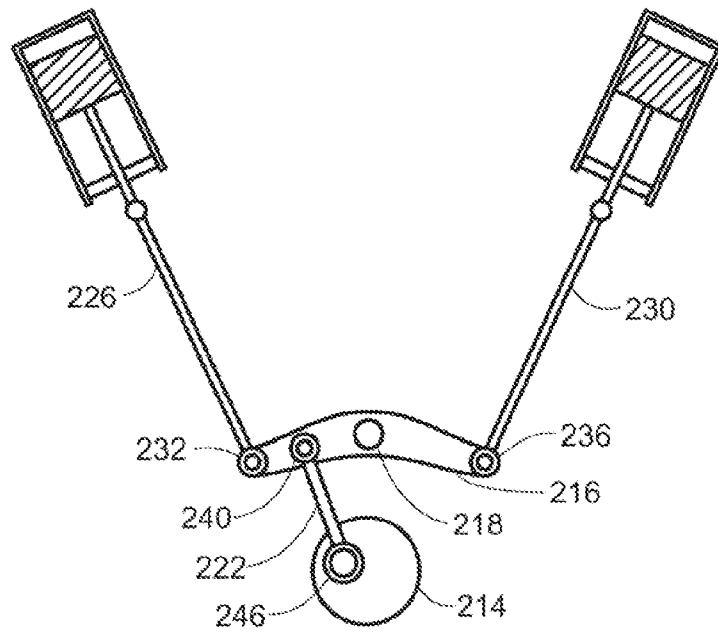

FIG. 5D

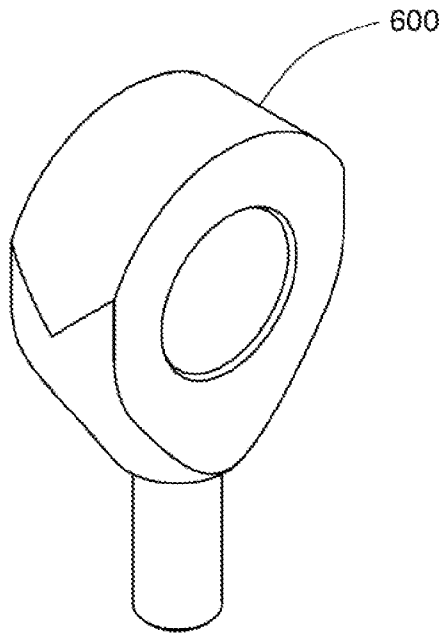

FIG. 6

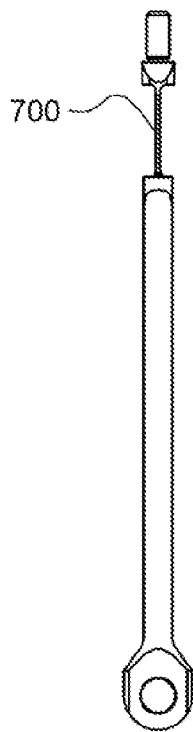

FIG. 7A

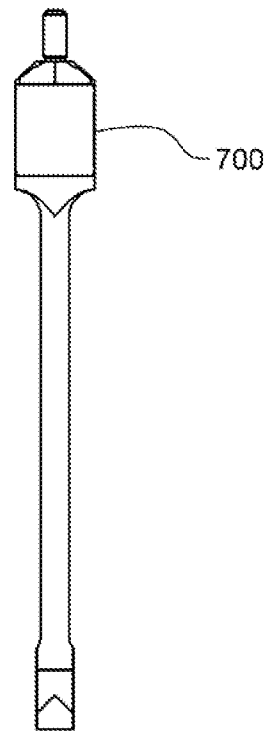

FIG. 7B

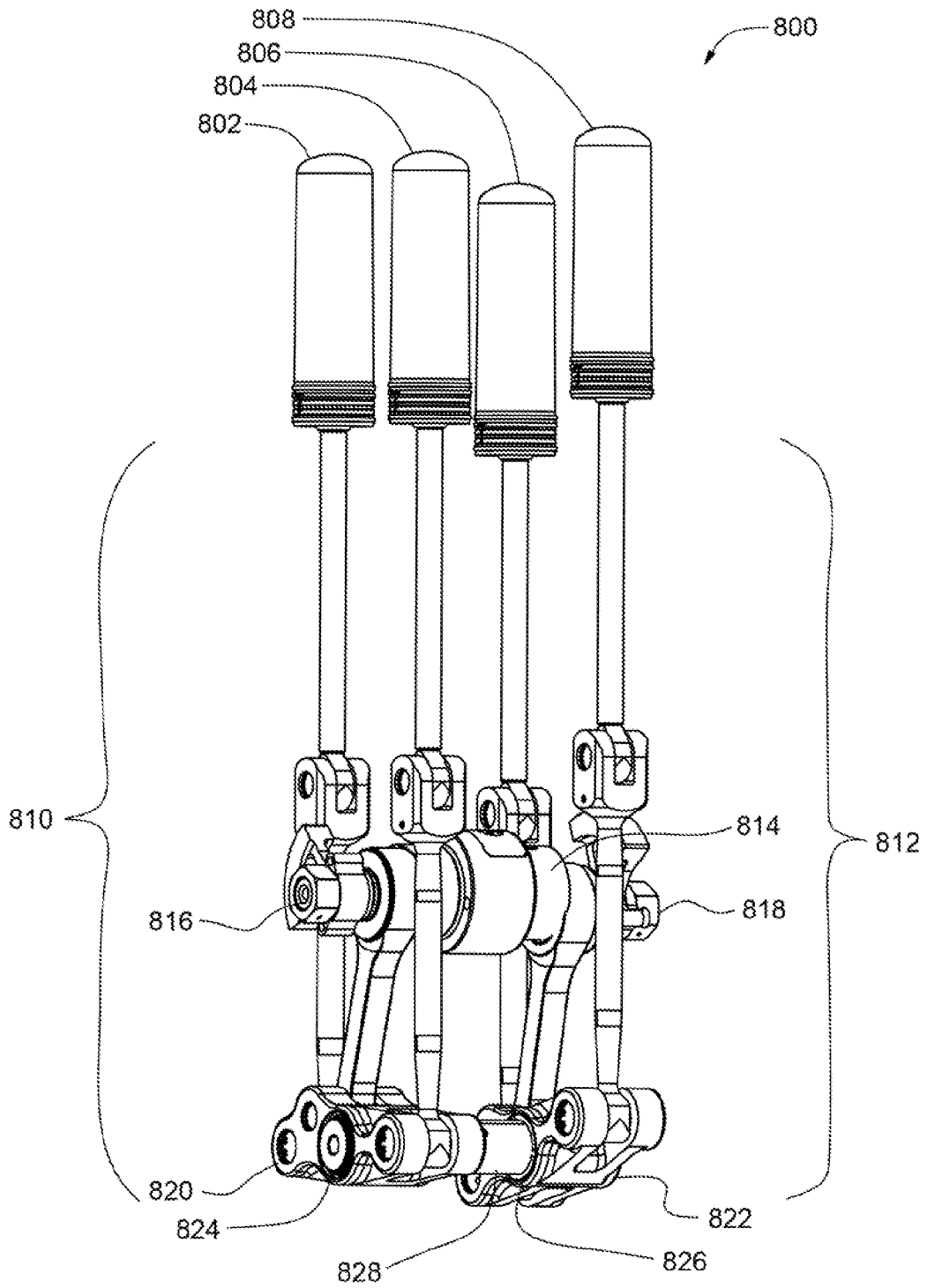

FIG. 8

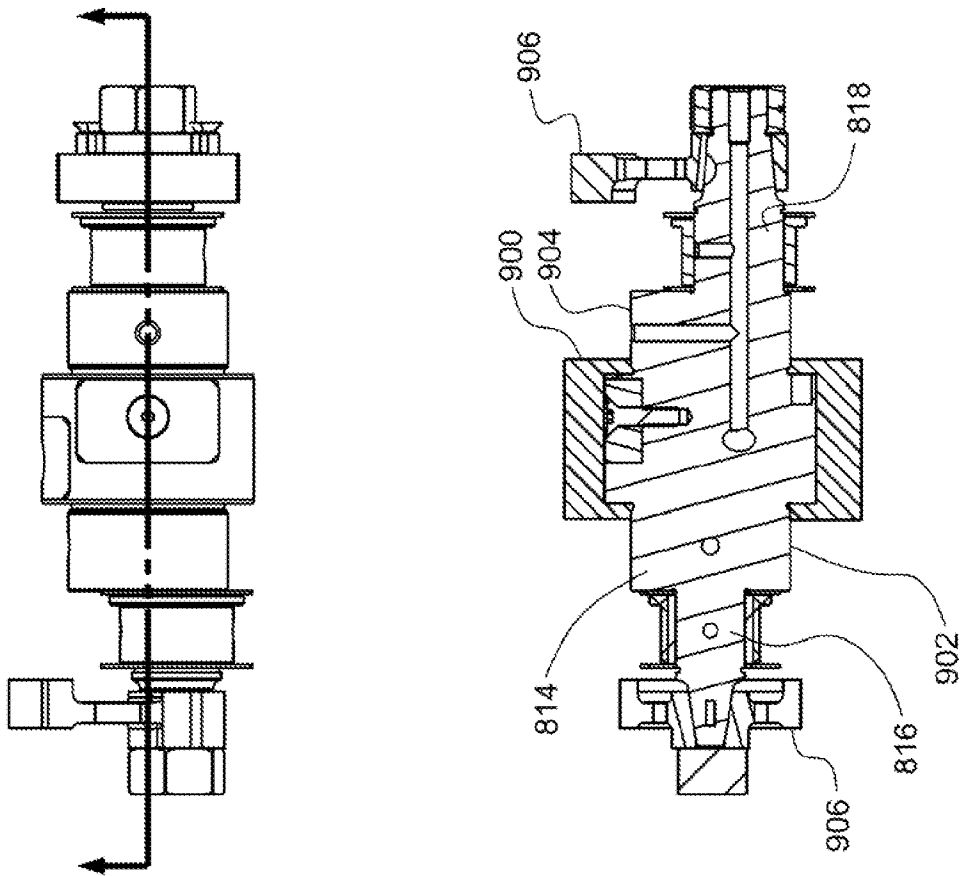

FIG. 9

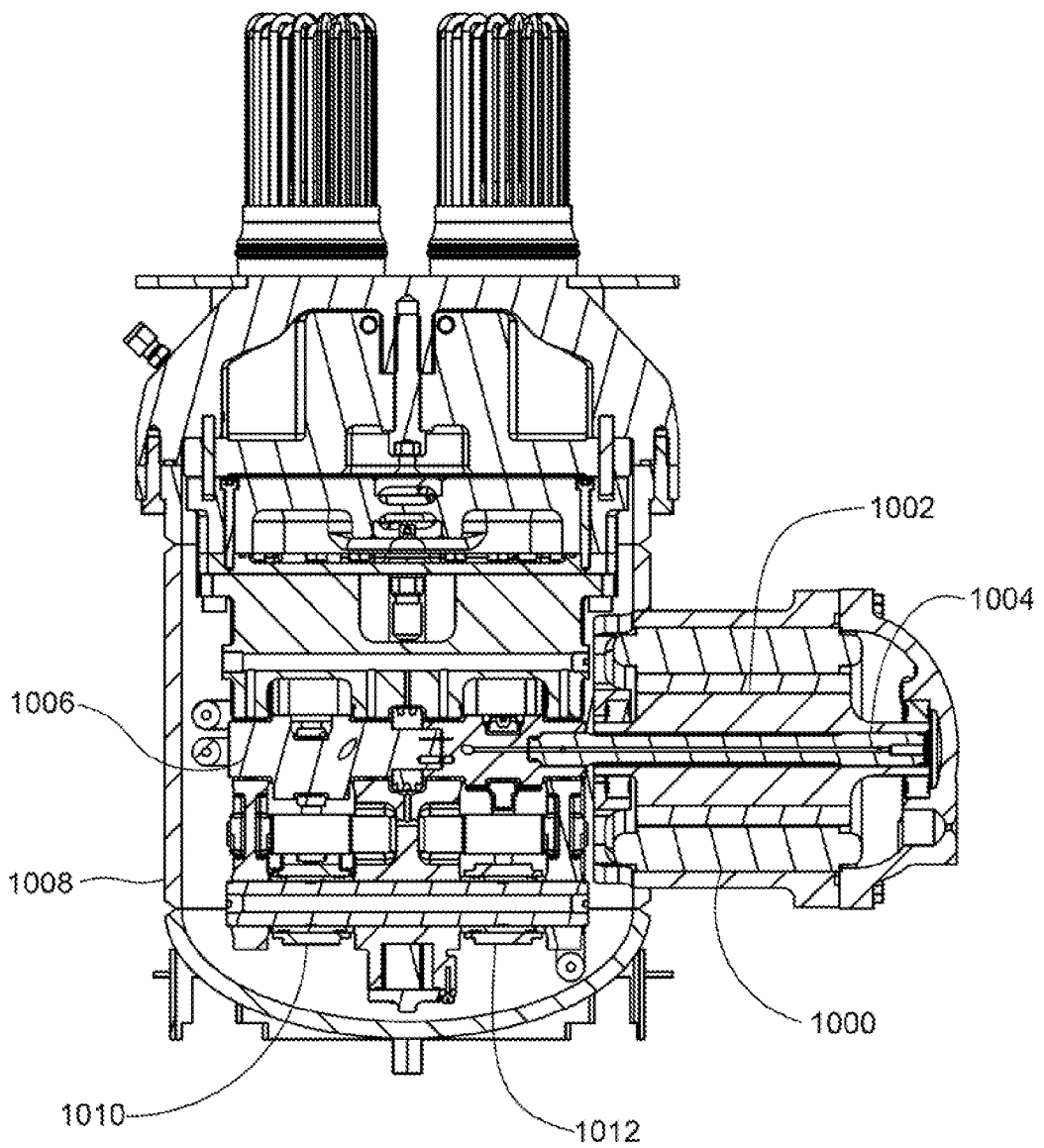
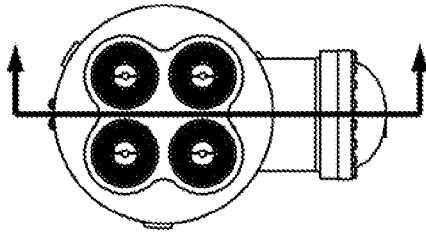

FIG. 10A

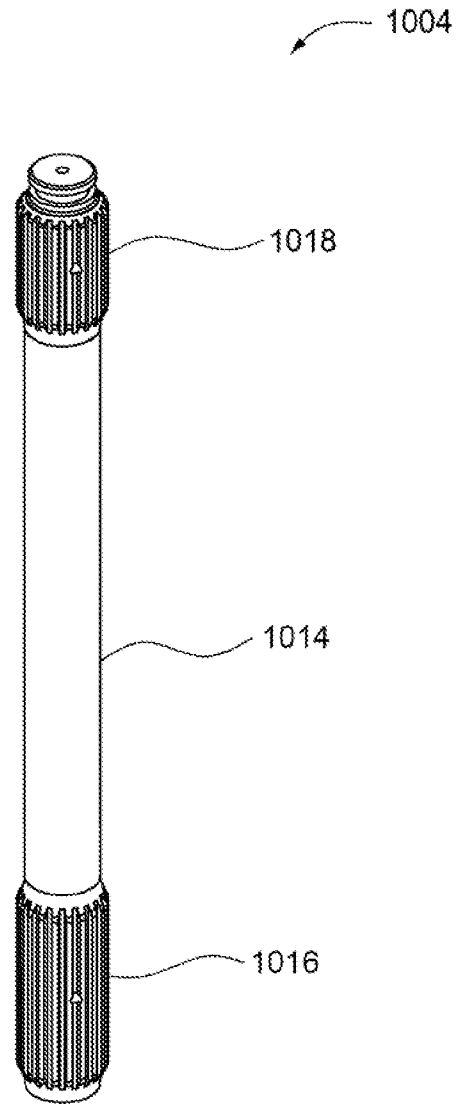

FIG. 10B

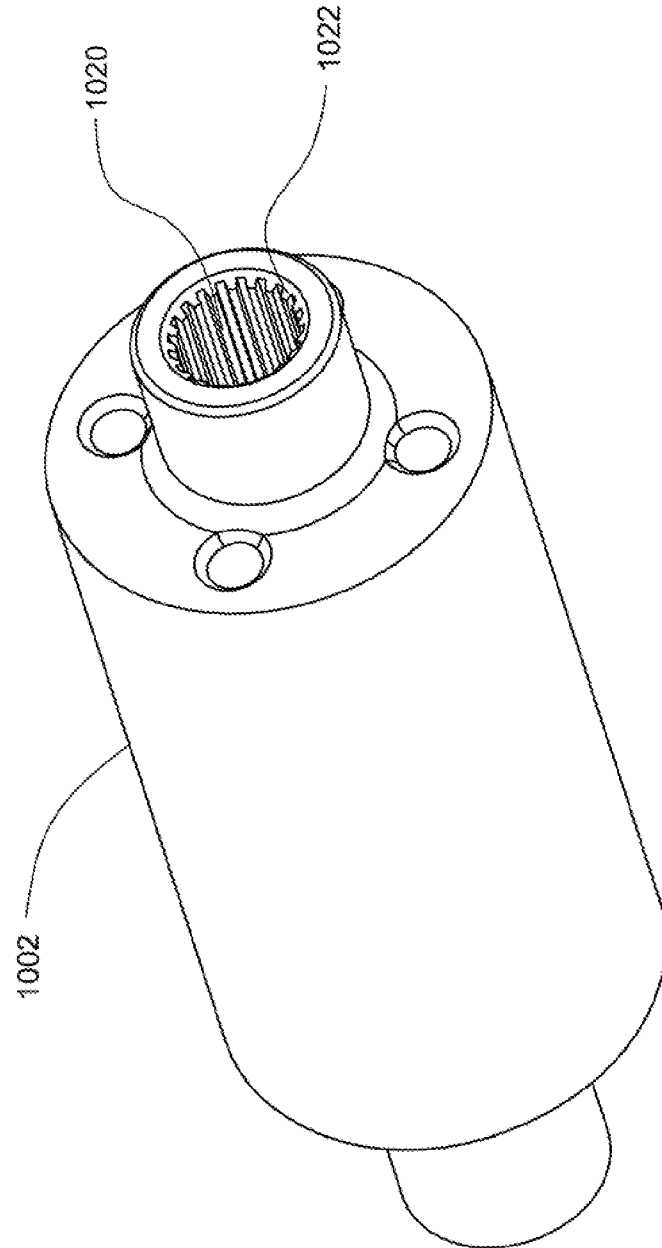

FIG. 10C

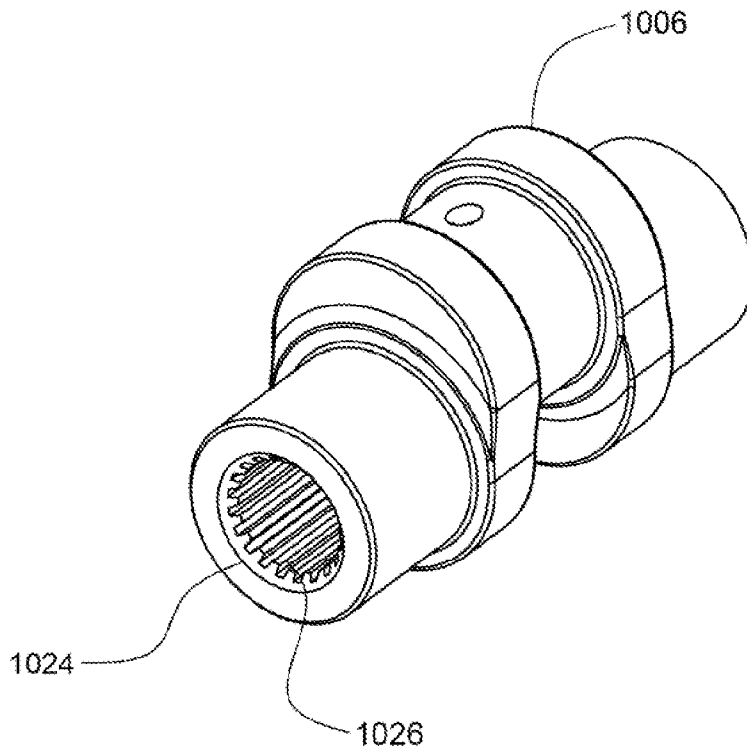

FIG. 10D

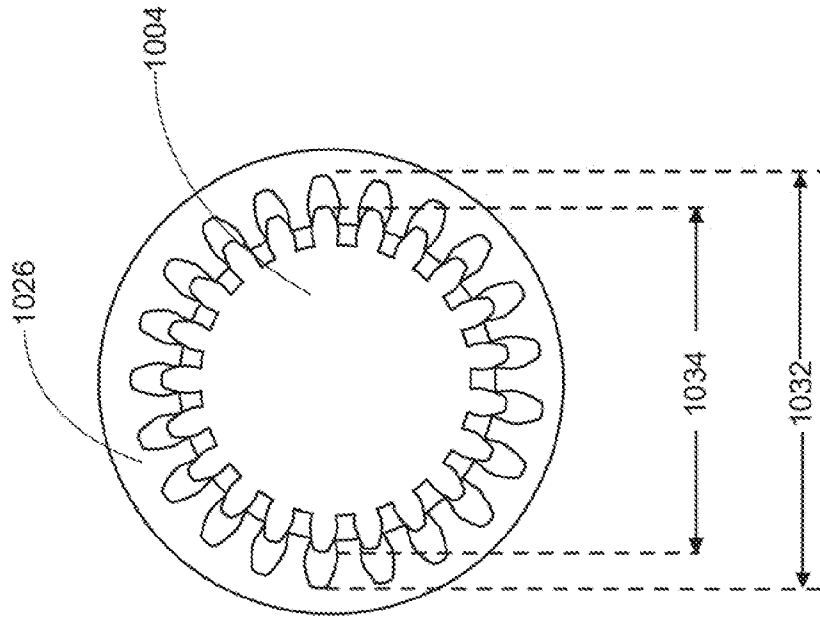

FIG. 10E



FIG. 10F

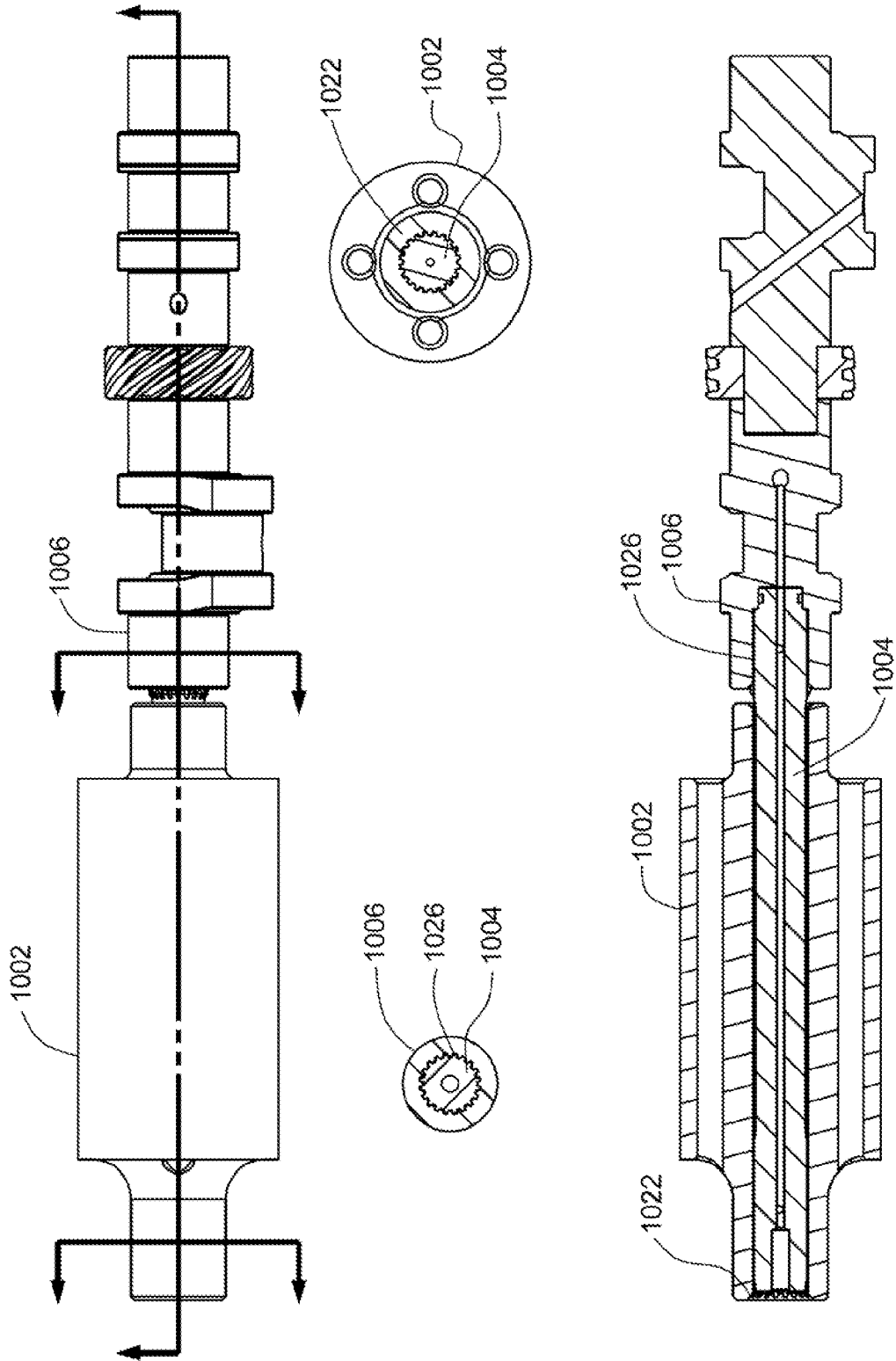

FIG. 10G

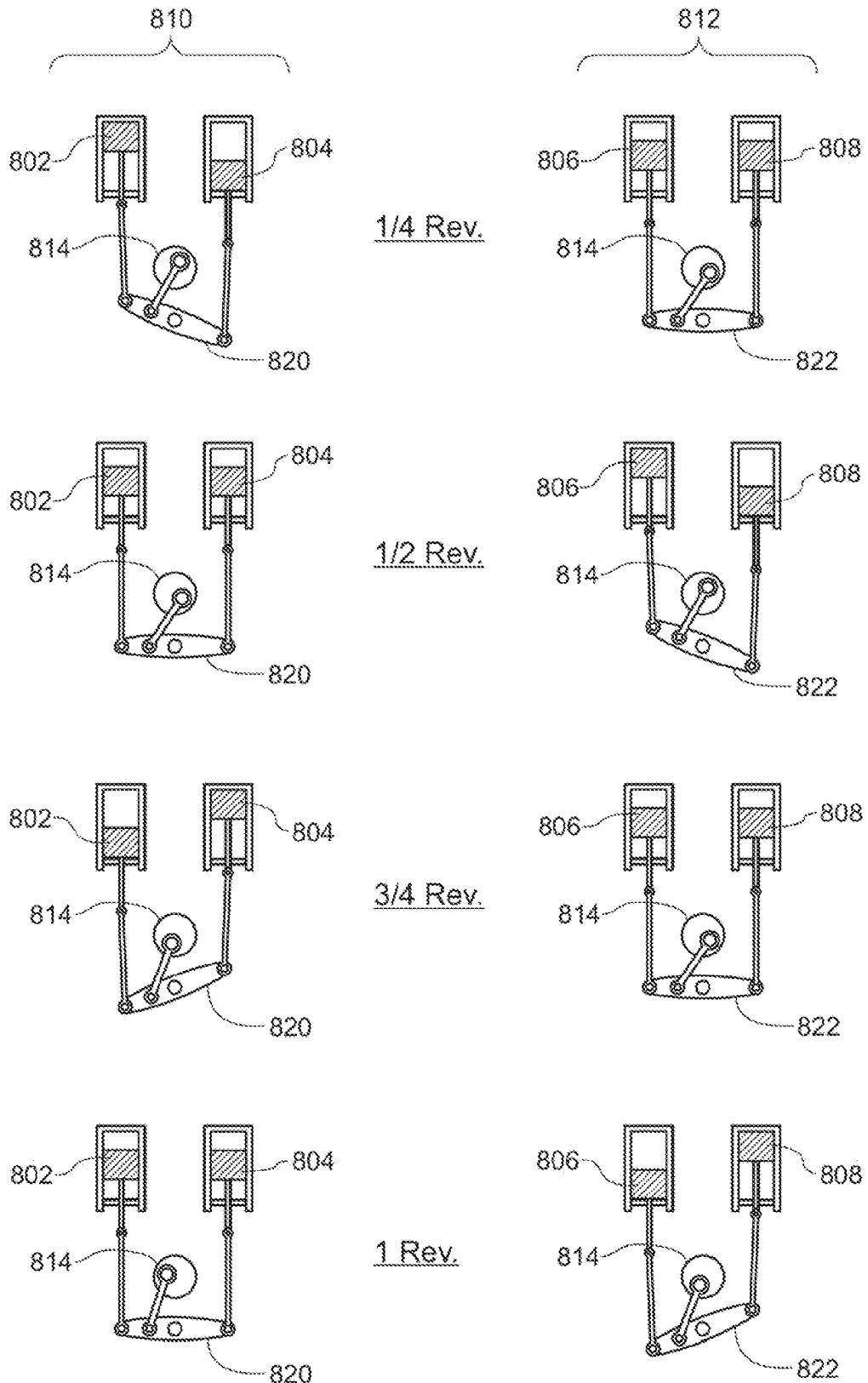

FIG. 11

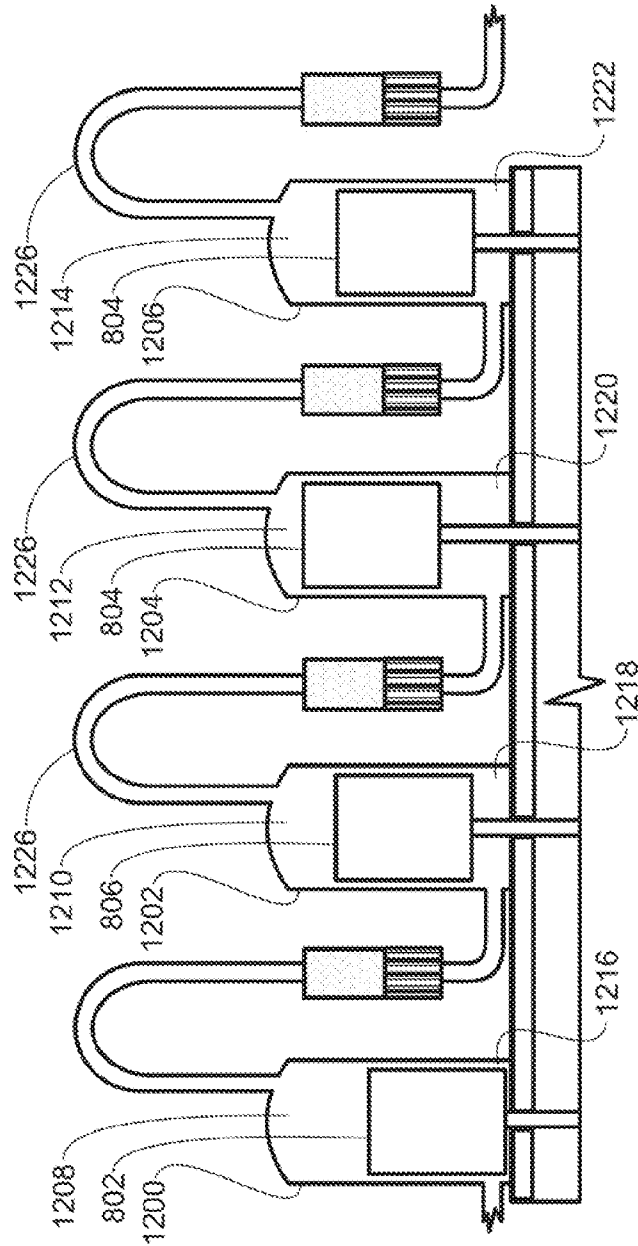

FIG.12A

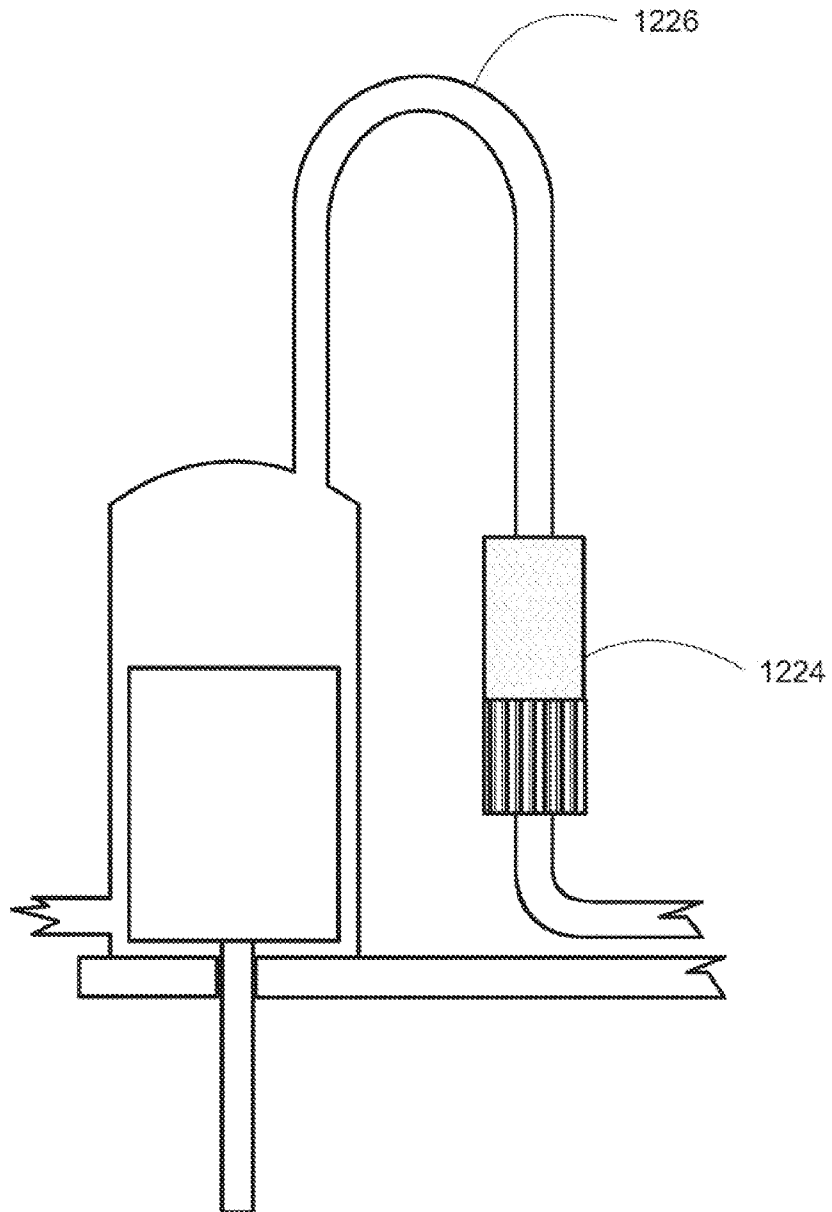

FIG.12B

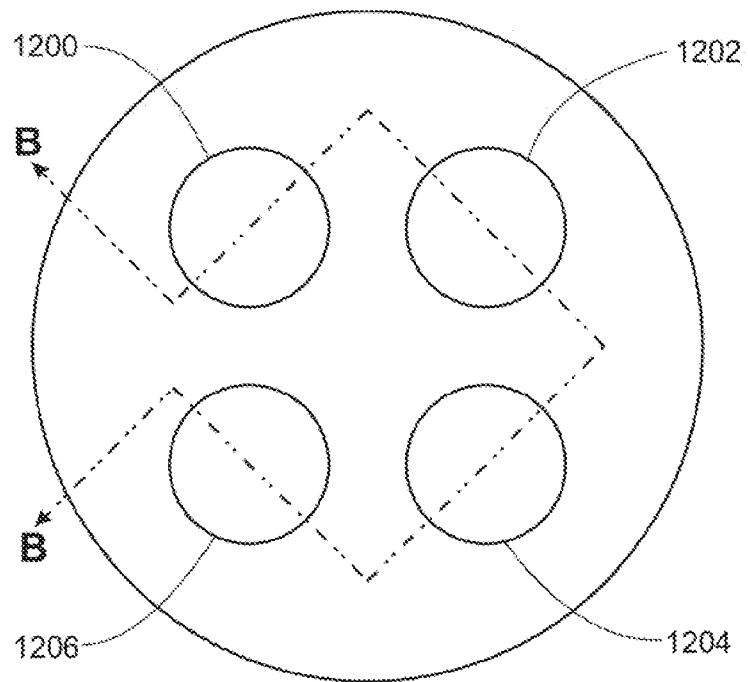

FIG. 12C

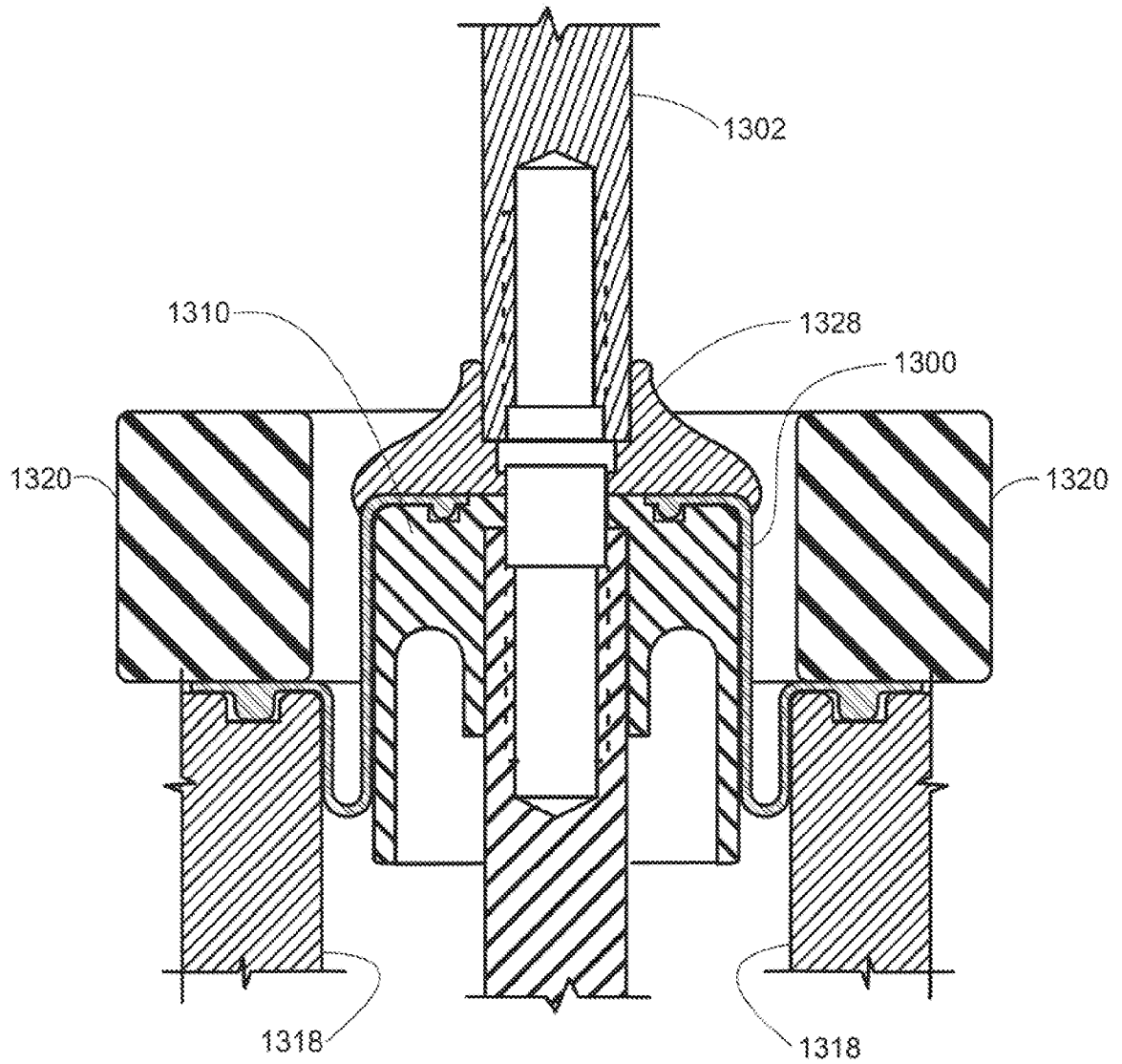

FIG. 13A

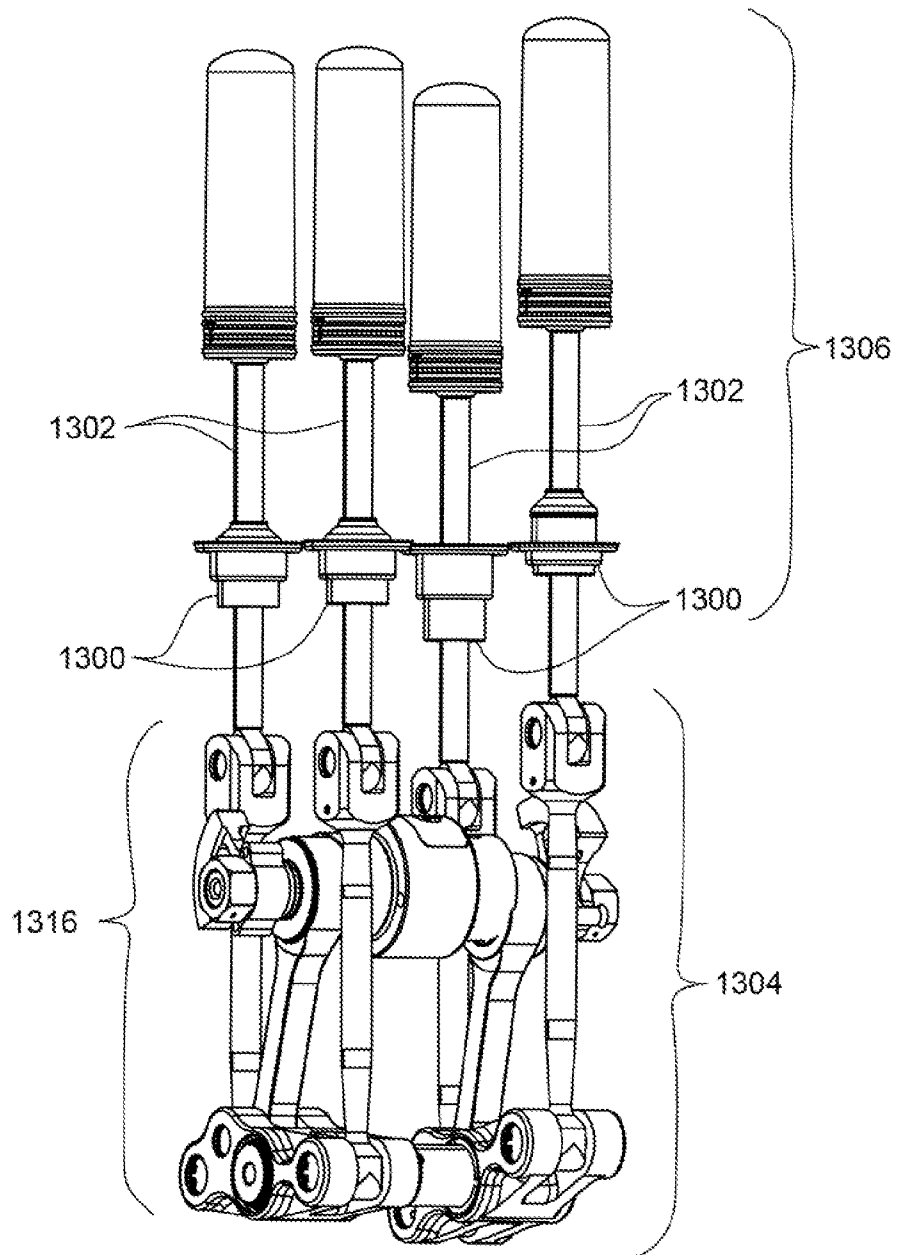

FIG. 13B

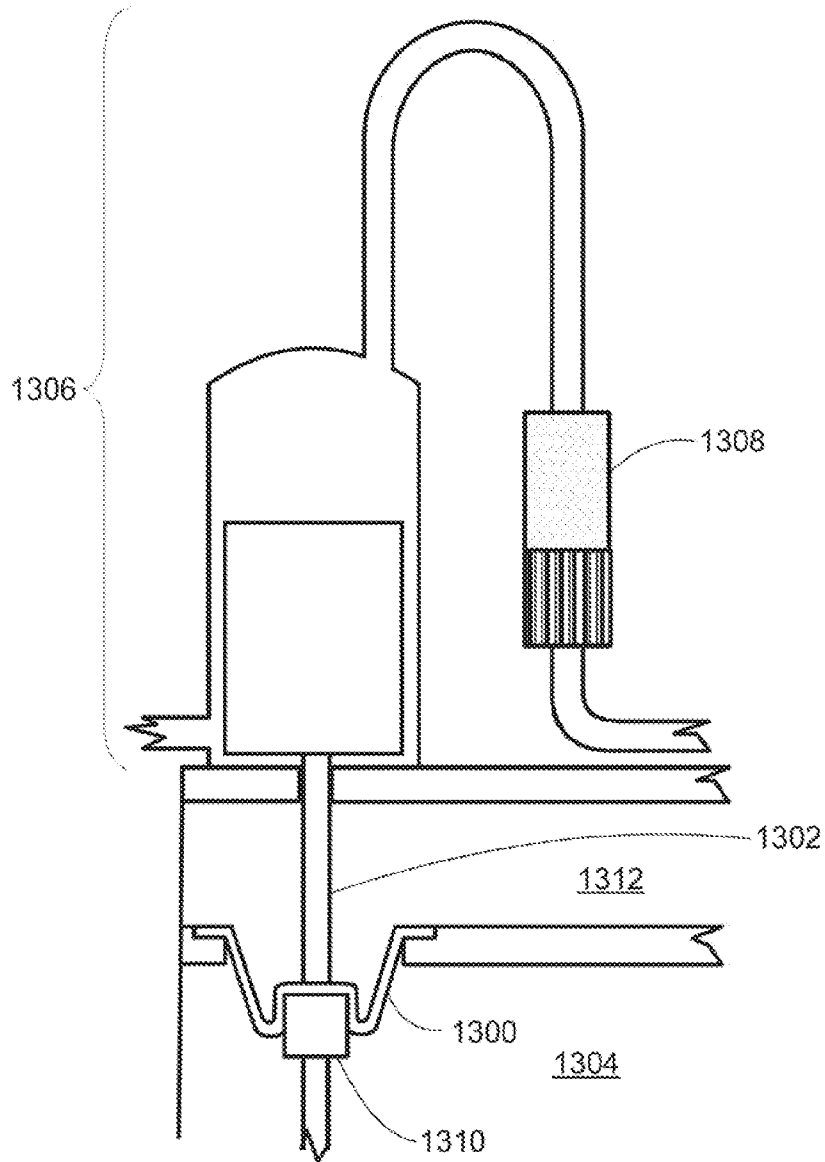

FIG.13C

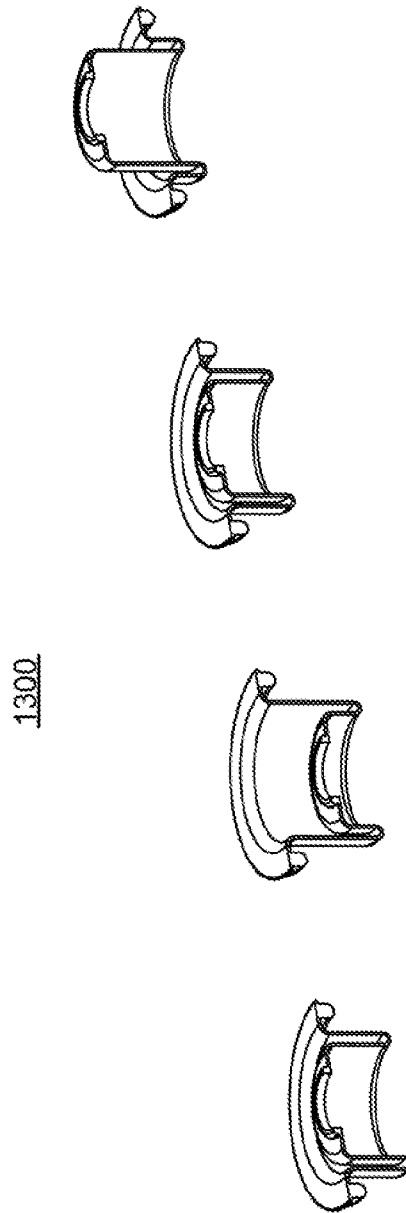

FIG. 13D

1300



FIG. 13E

+

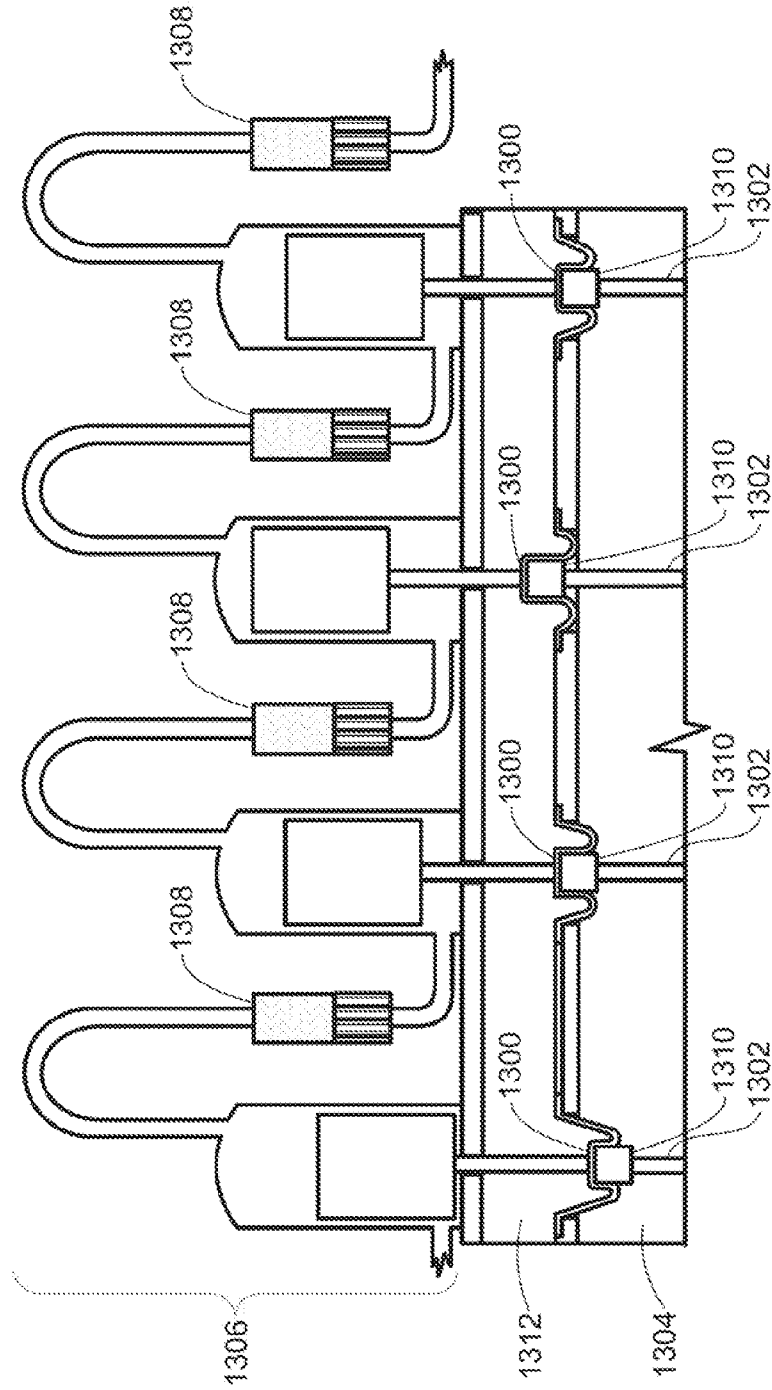

FIG.13F

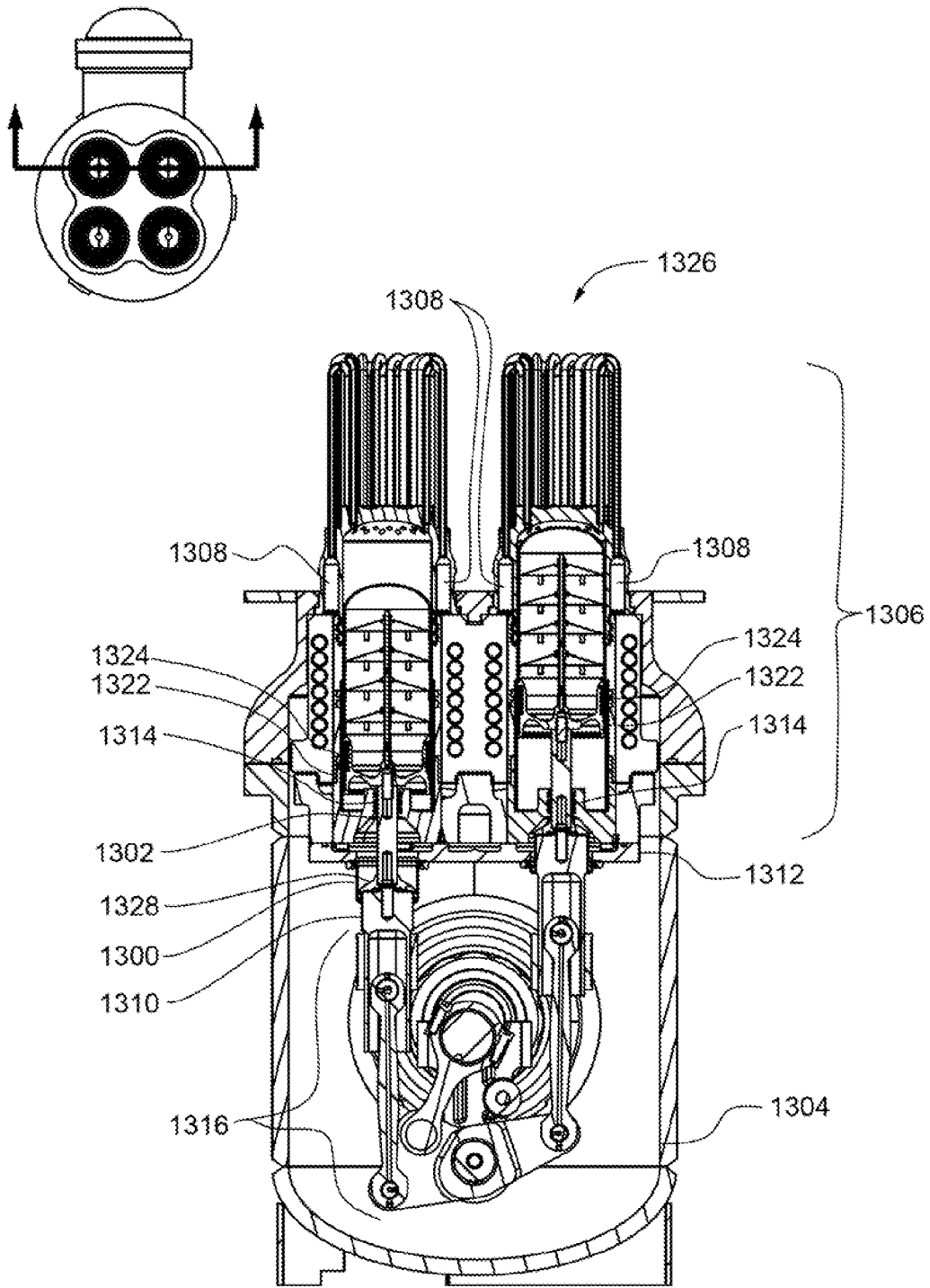

FIG. 13G

FIG. 14A

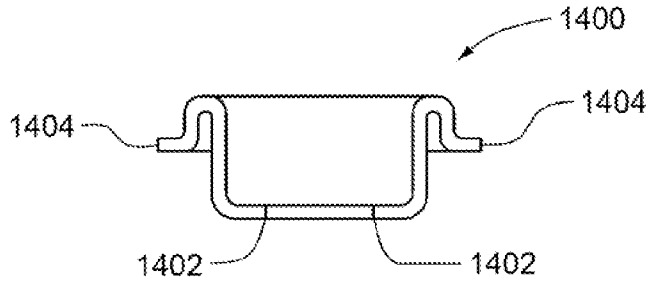

FIG. 14B

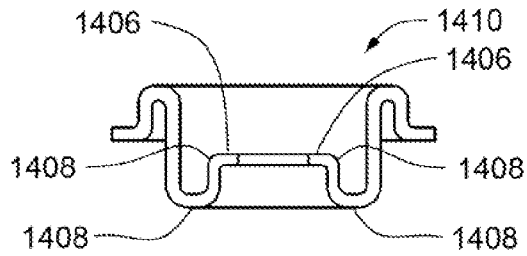

FIG. 14C

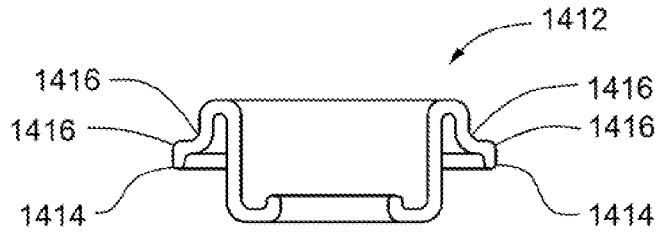

FIG. 14D

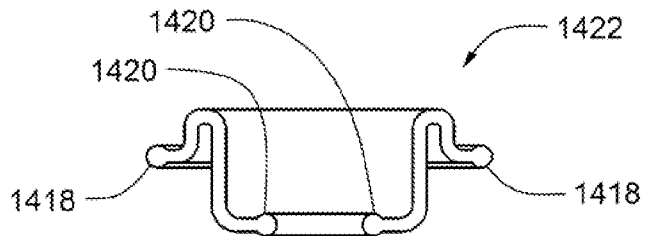
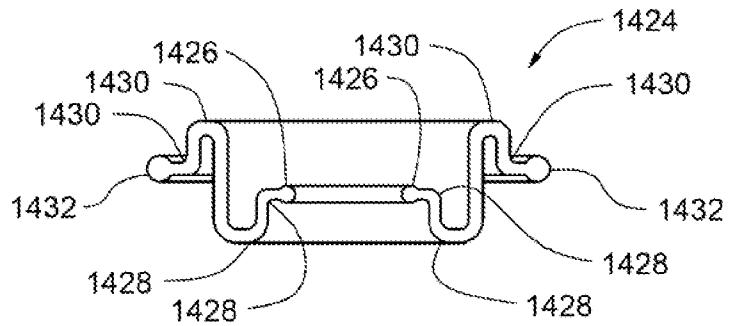

FIG. 14E



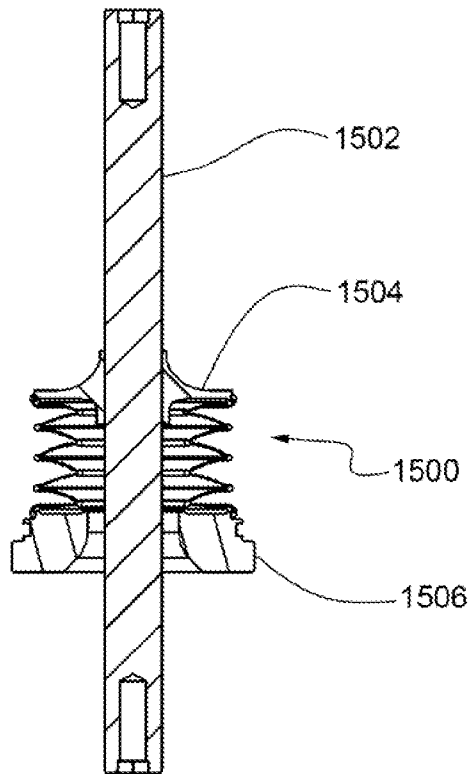
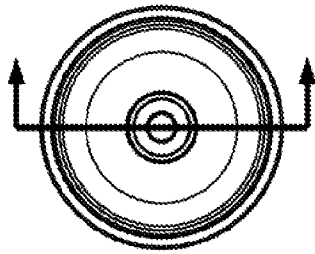

FIG. 15A

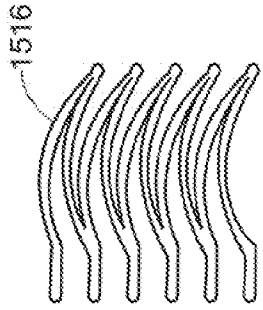

FIG. 15E

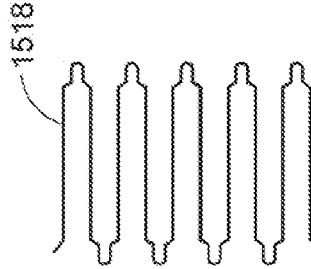

FIG. 15F

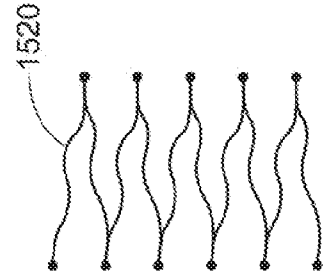

FIG. 15G

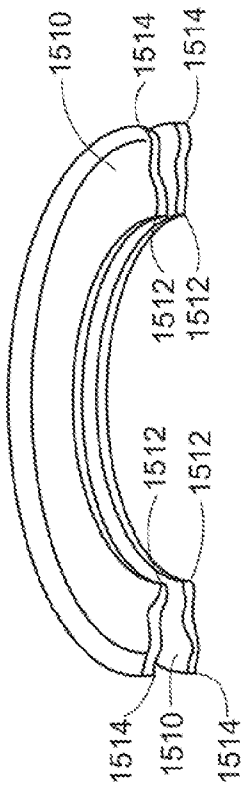

FIG. 15B

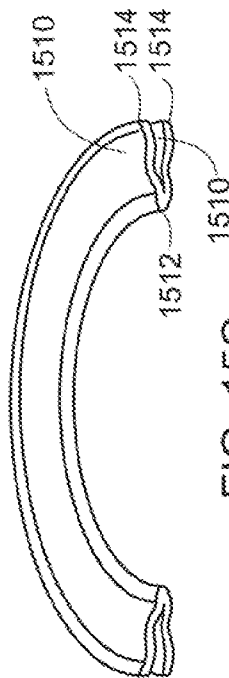

FIG. 15C

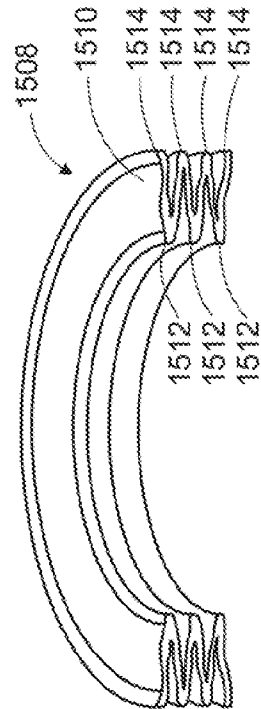

FIG. 15D

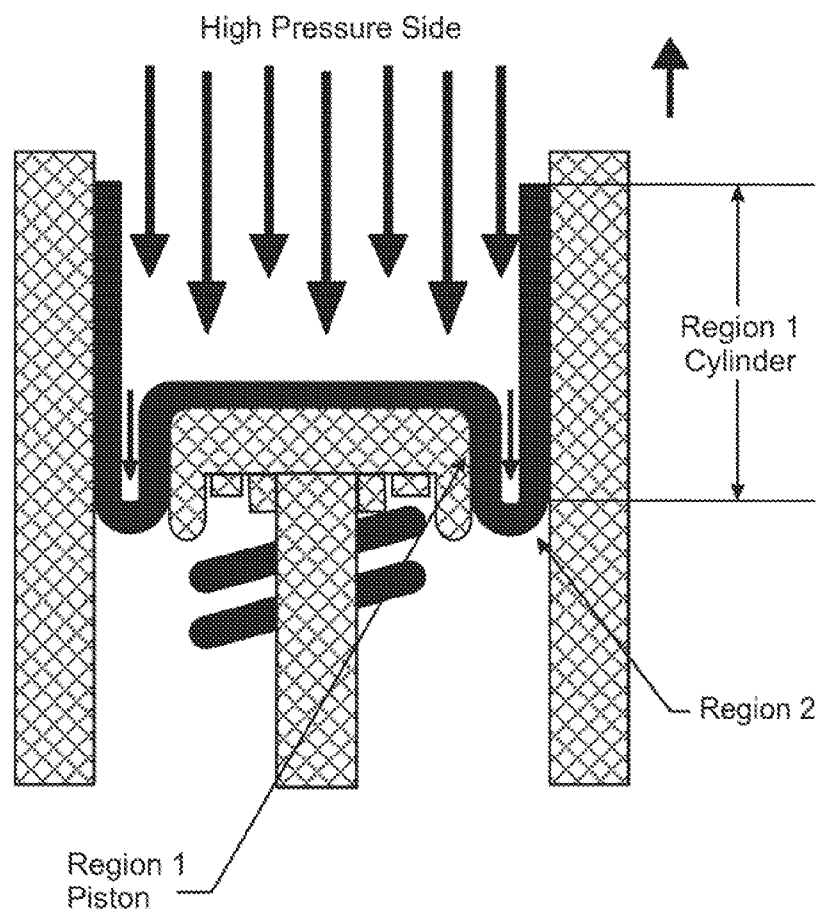

FIG.15H

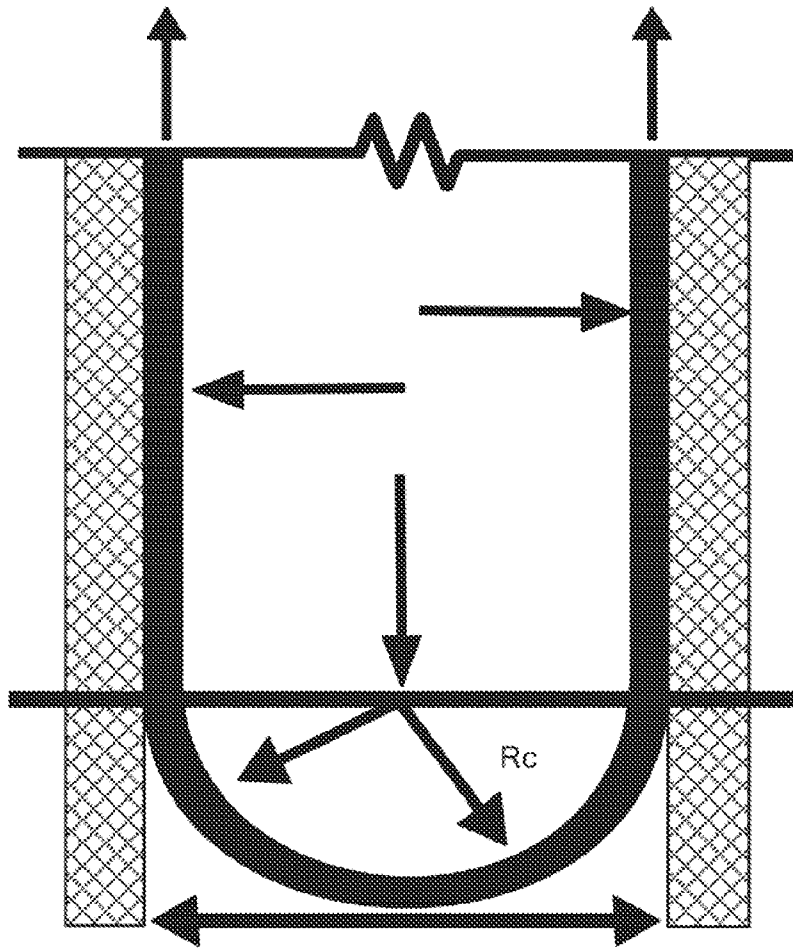

FIG.15I

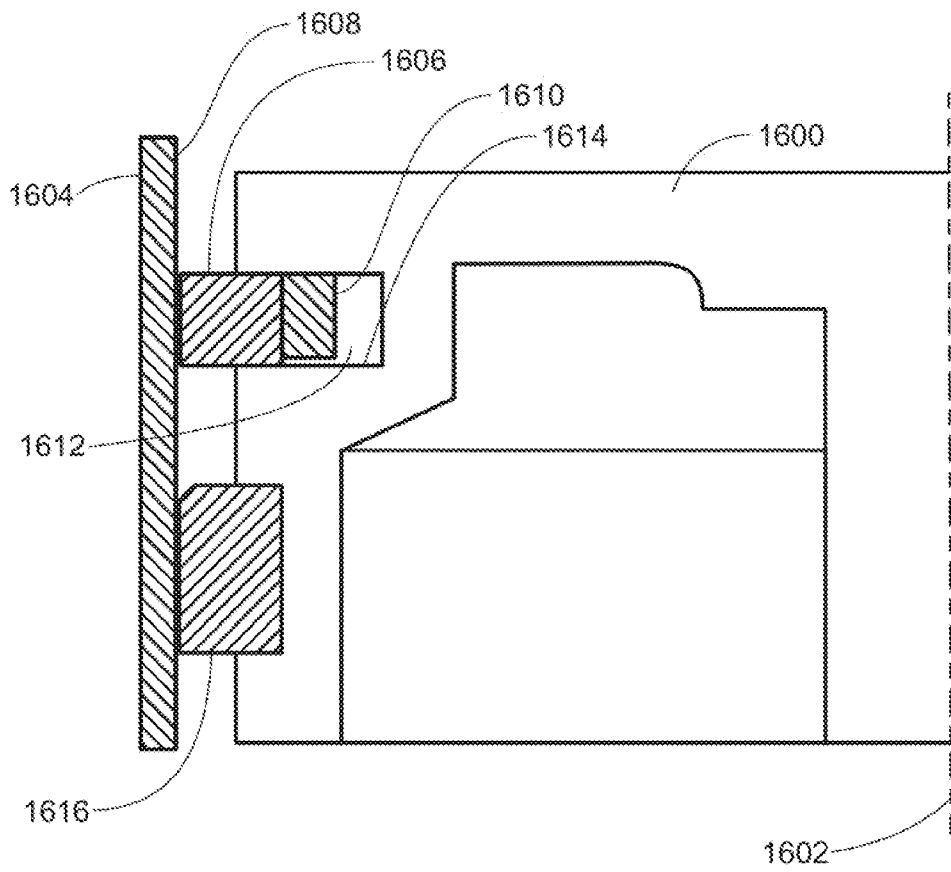

FIG. 16

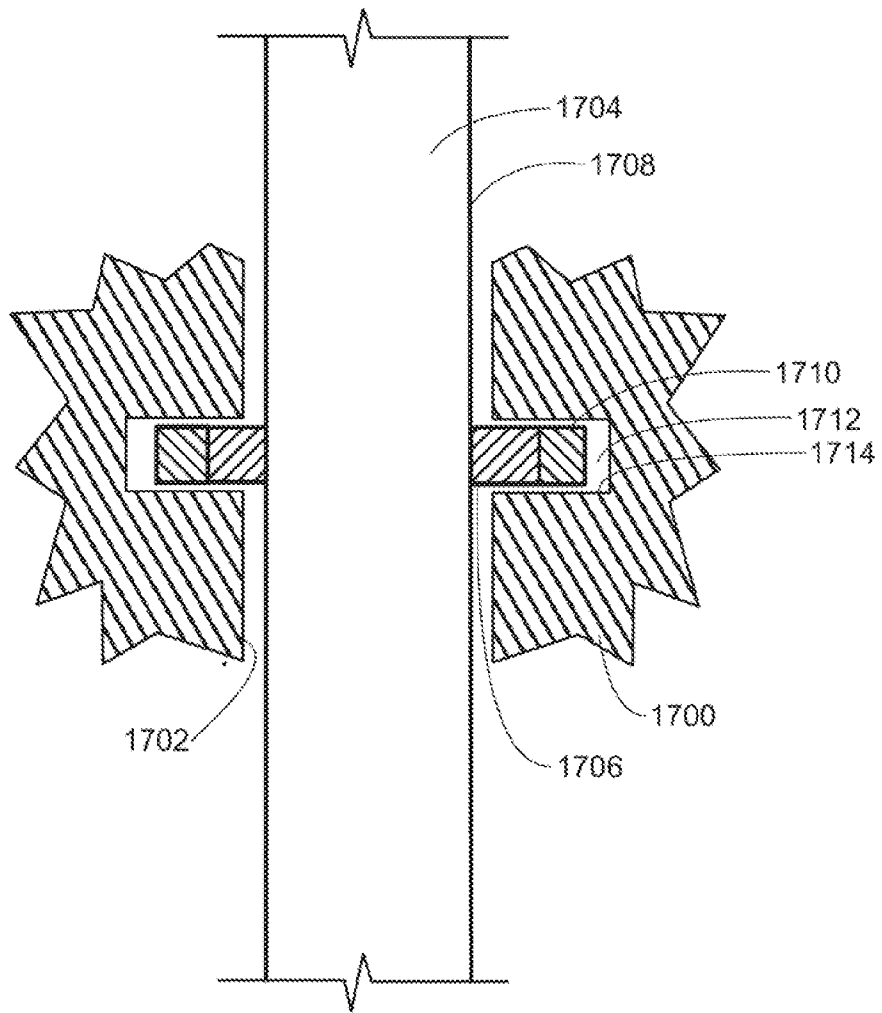

FIG. 17

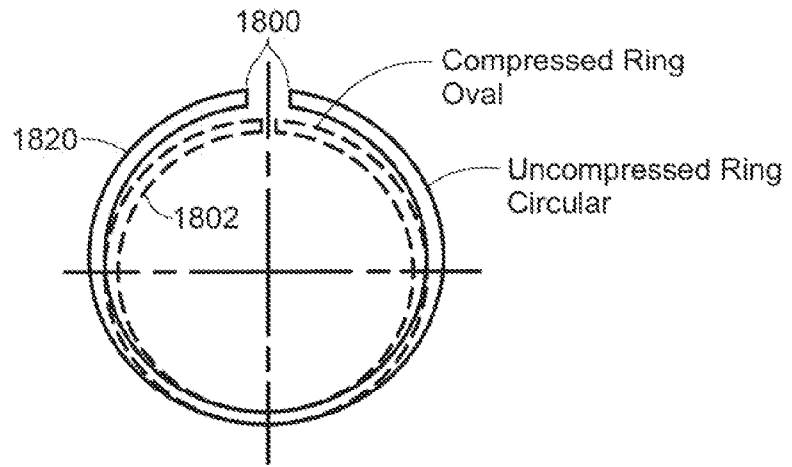

FIG. 18A

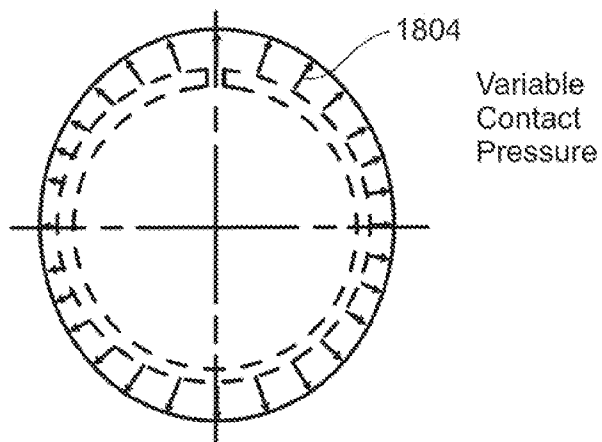

FIG. 18B

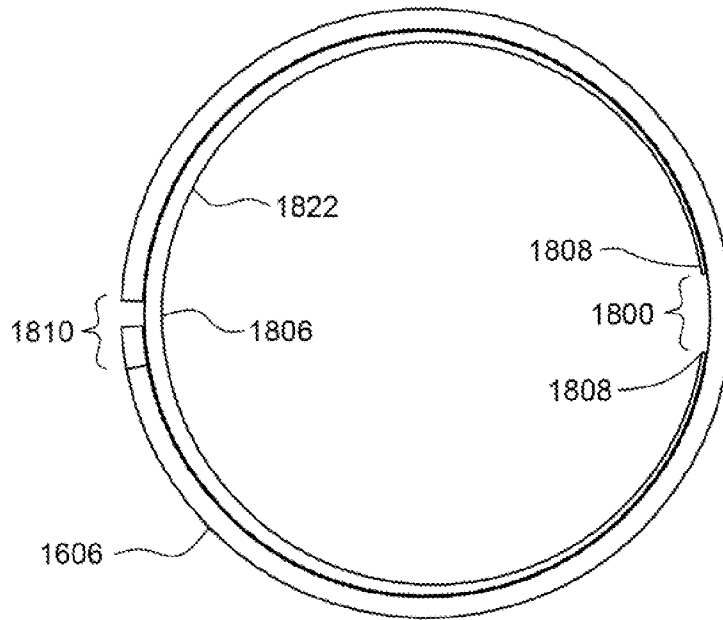

FIG. 18C

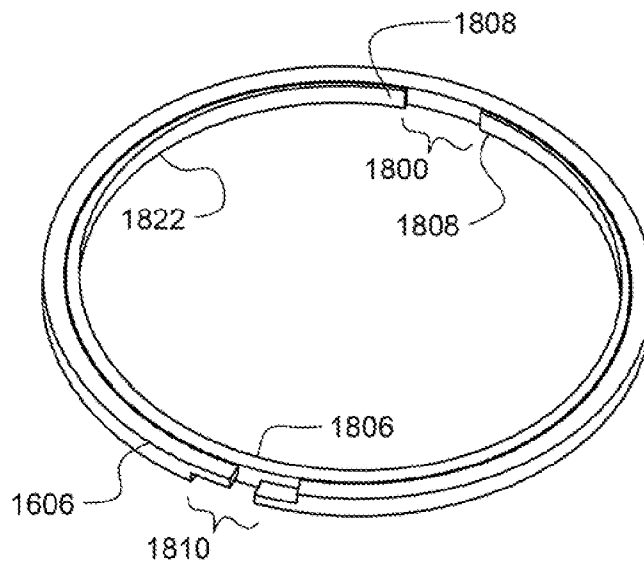

FIG. 18D

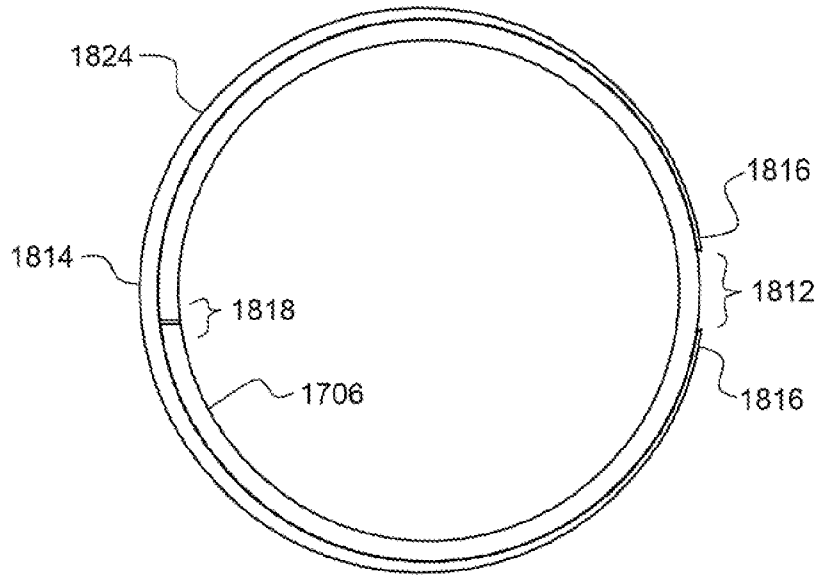

FIG. 18E

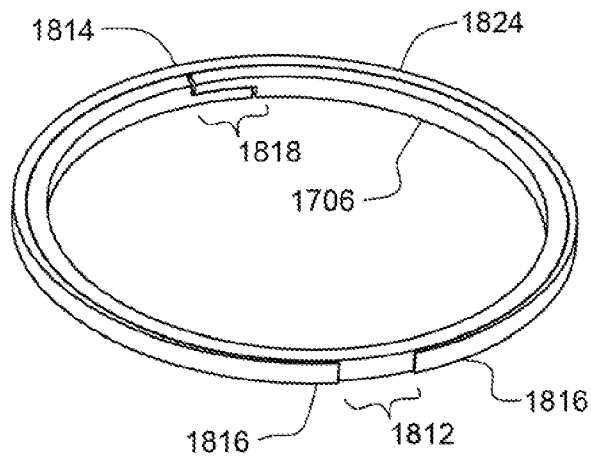

FIG. 18F

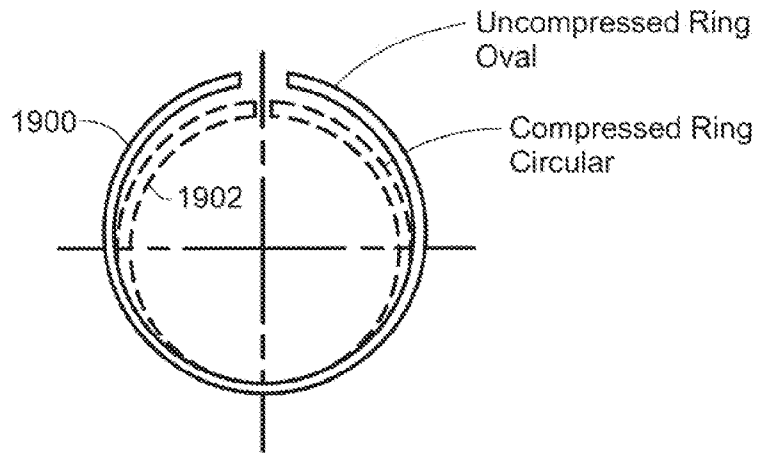

FIG. 19A

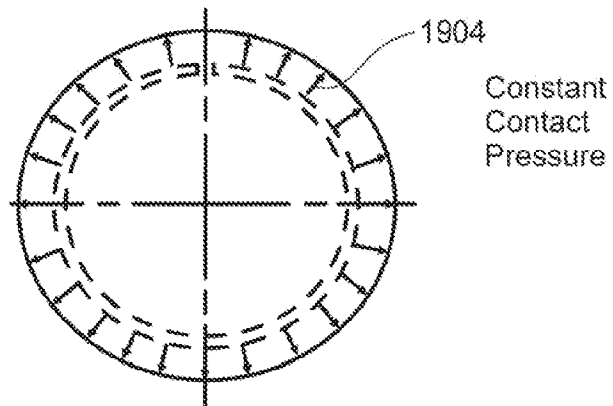

FIG. 19B

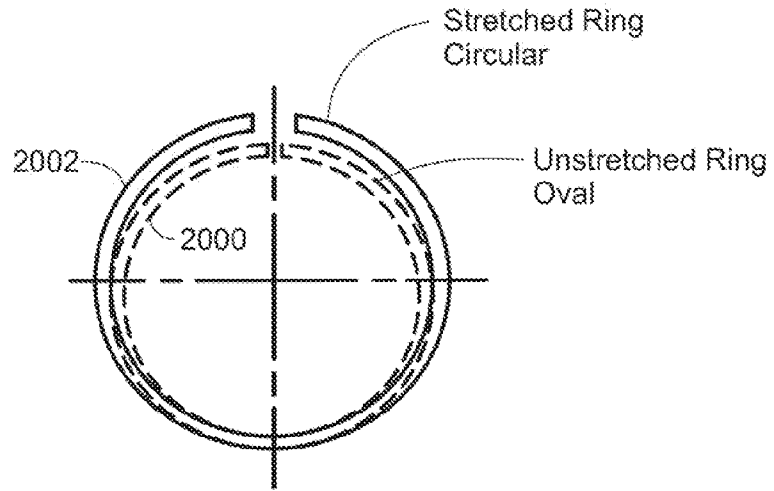

FIG. 20A

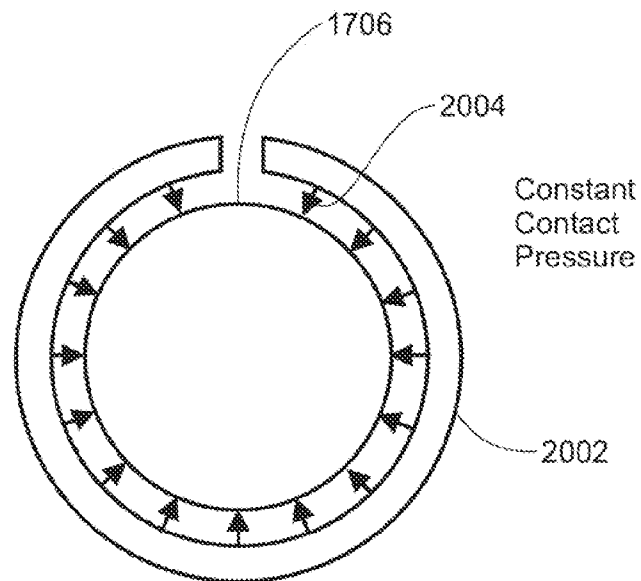
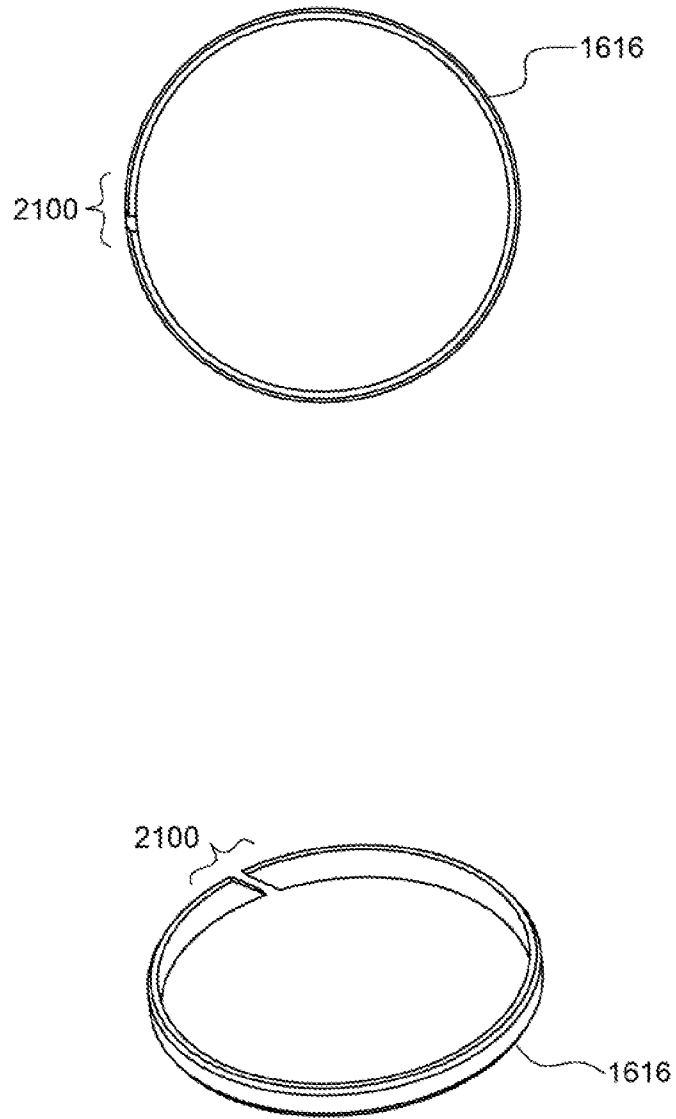

FIG. 20B



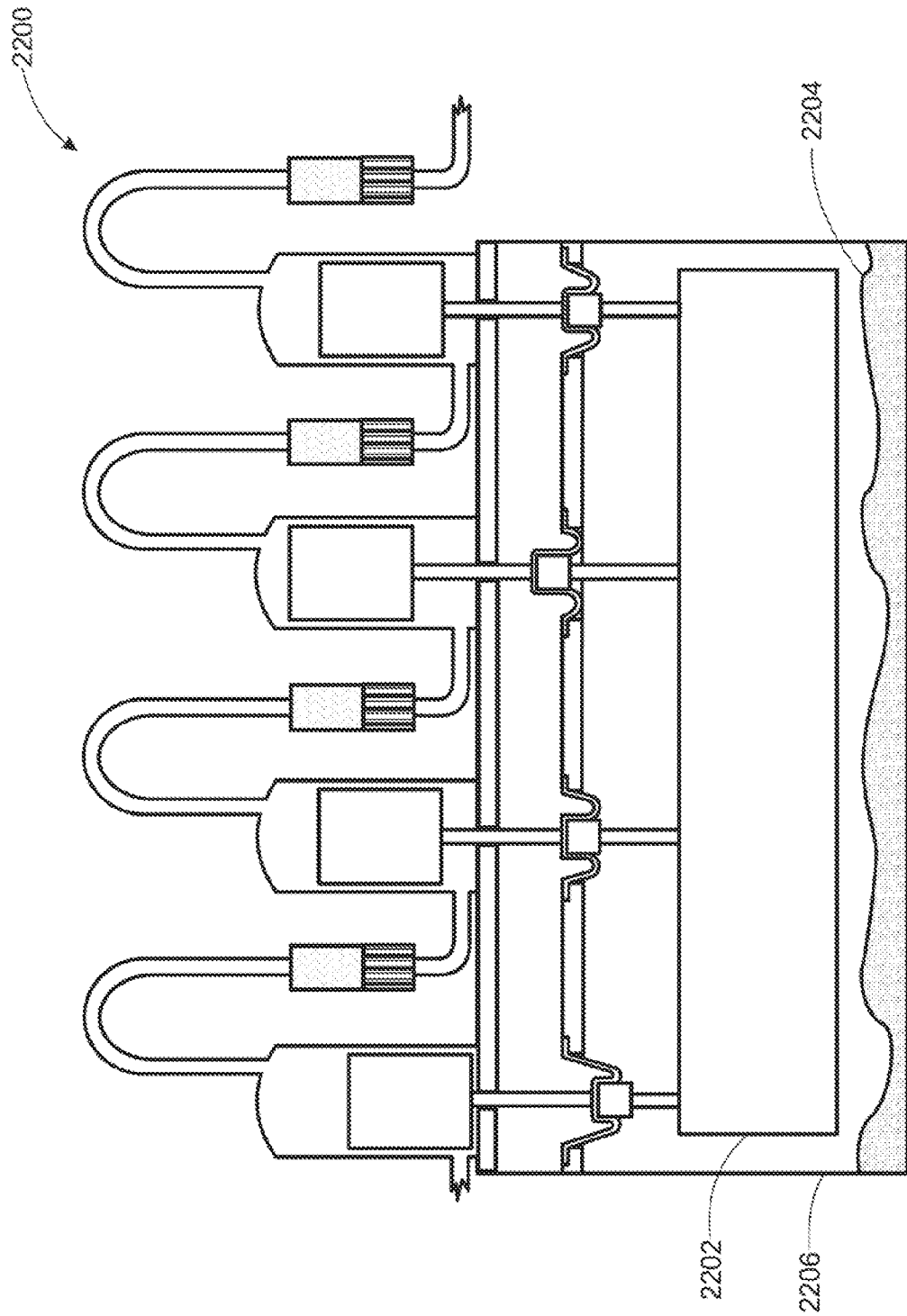

FIG. 22

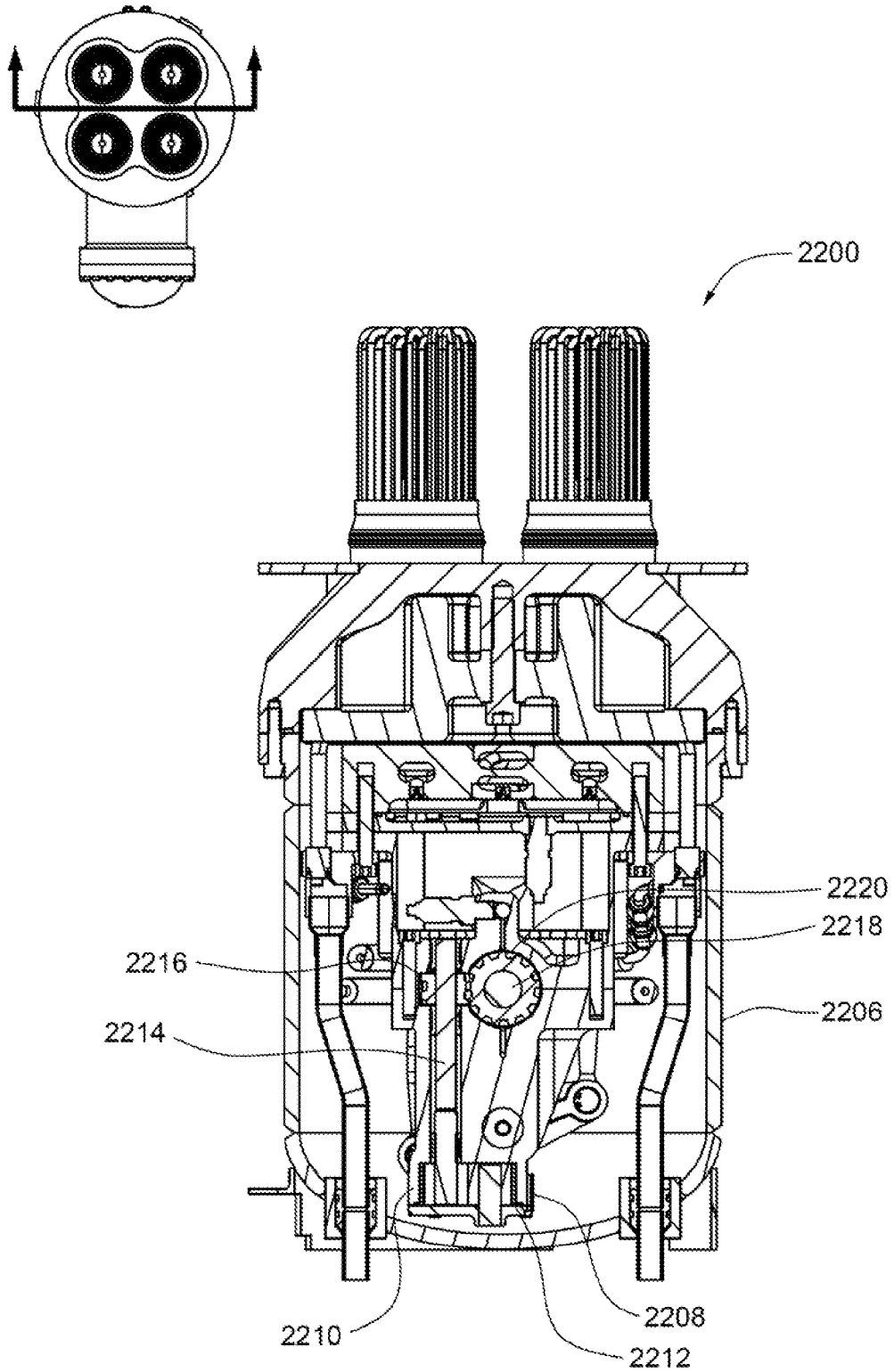

FIG. 23A

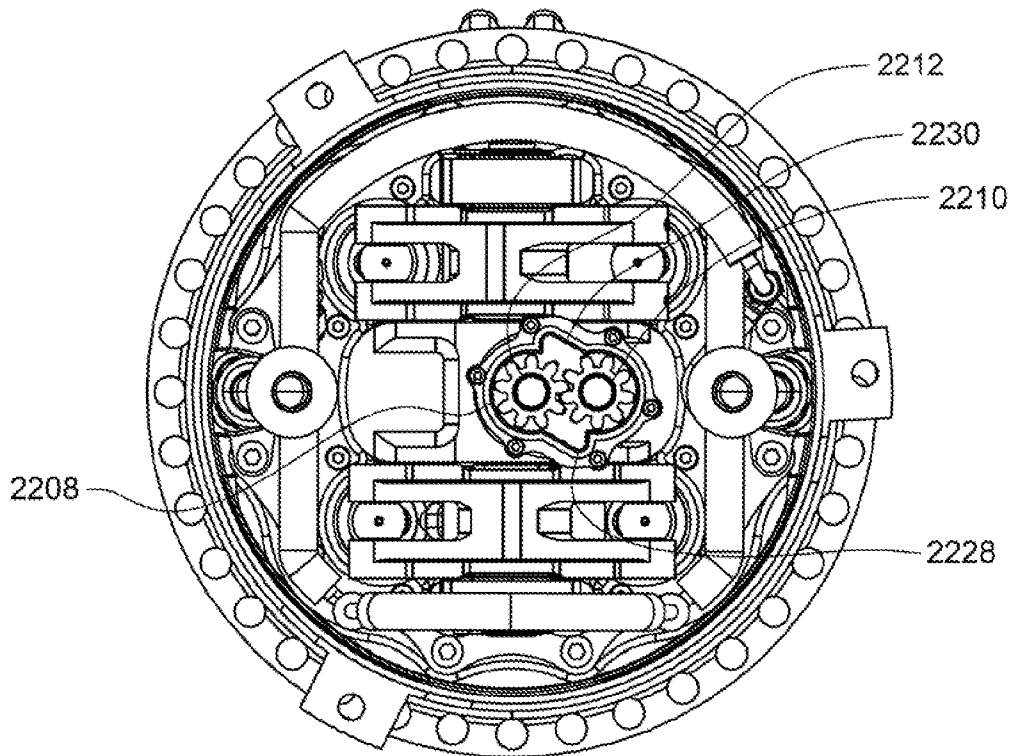

FIG. 23B

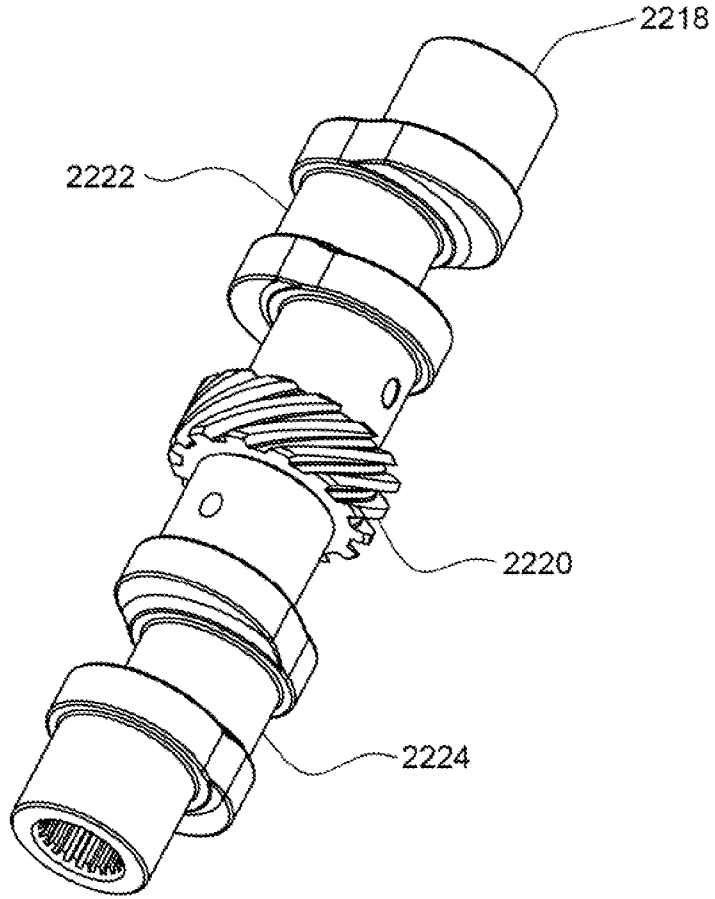

FIG. 24

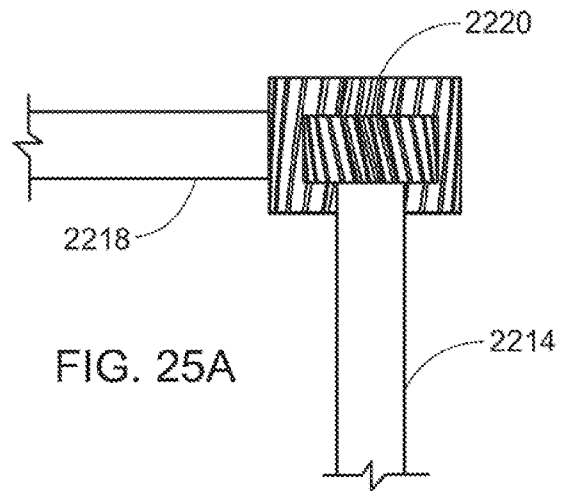

FIG. 25A

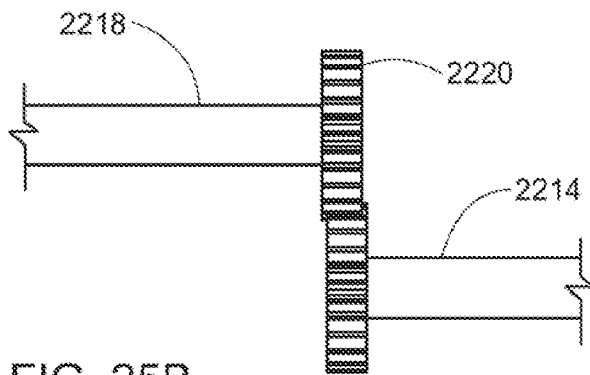

FIG. 25B

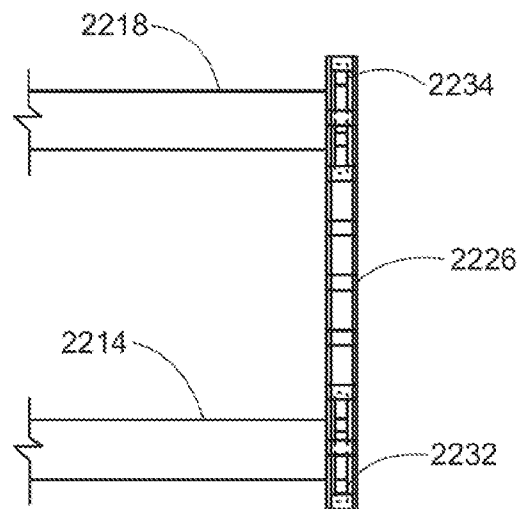

FIG. 25C

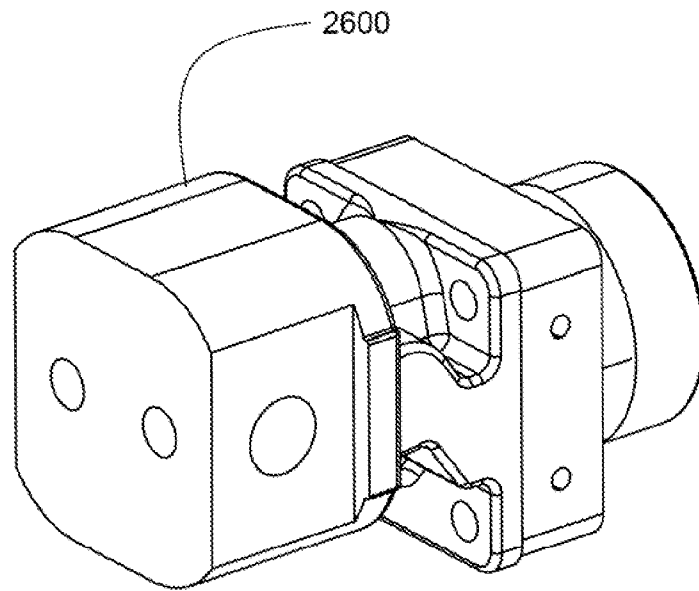

FIG. 26A

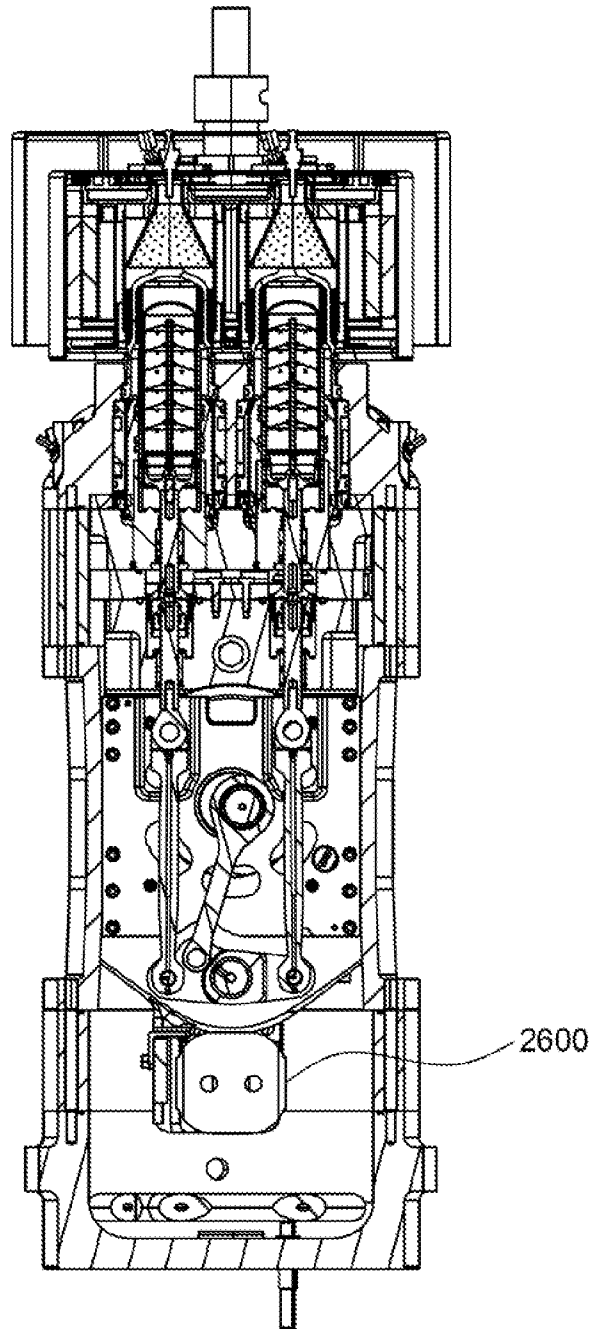

FIG. 26B

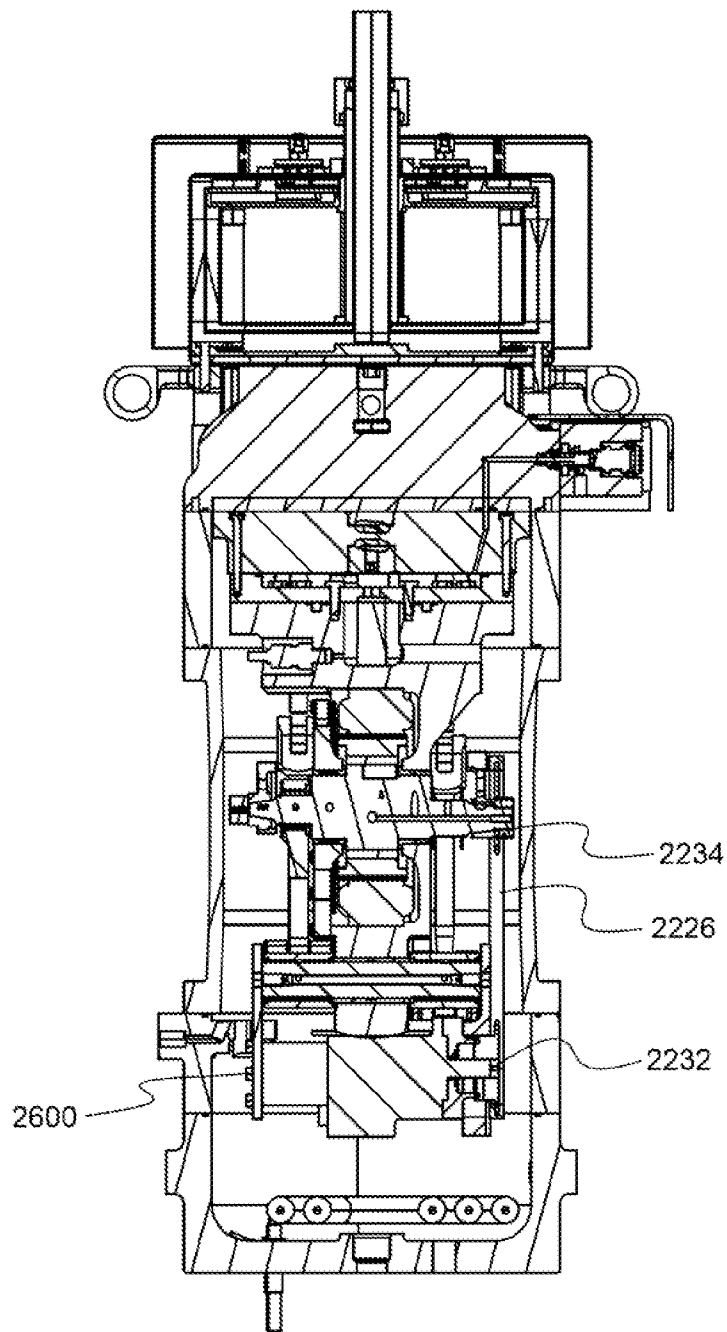

FIG. 26C

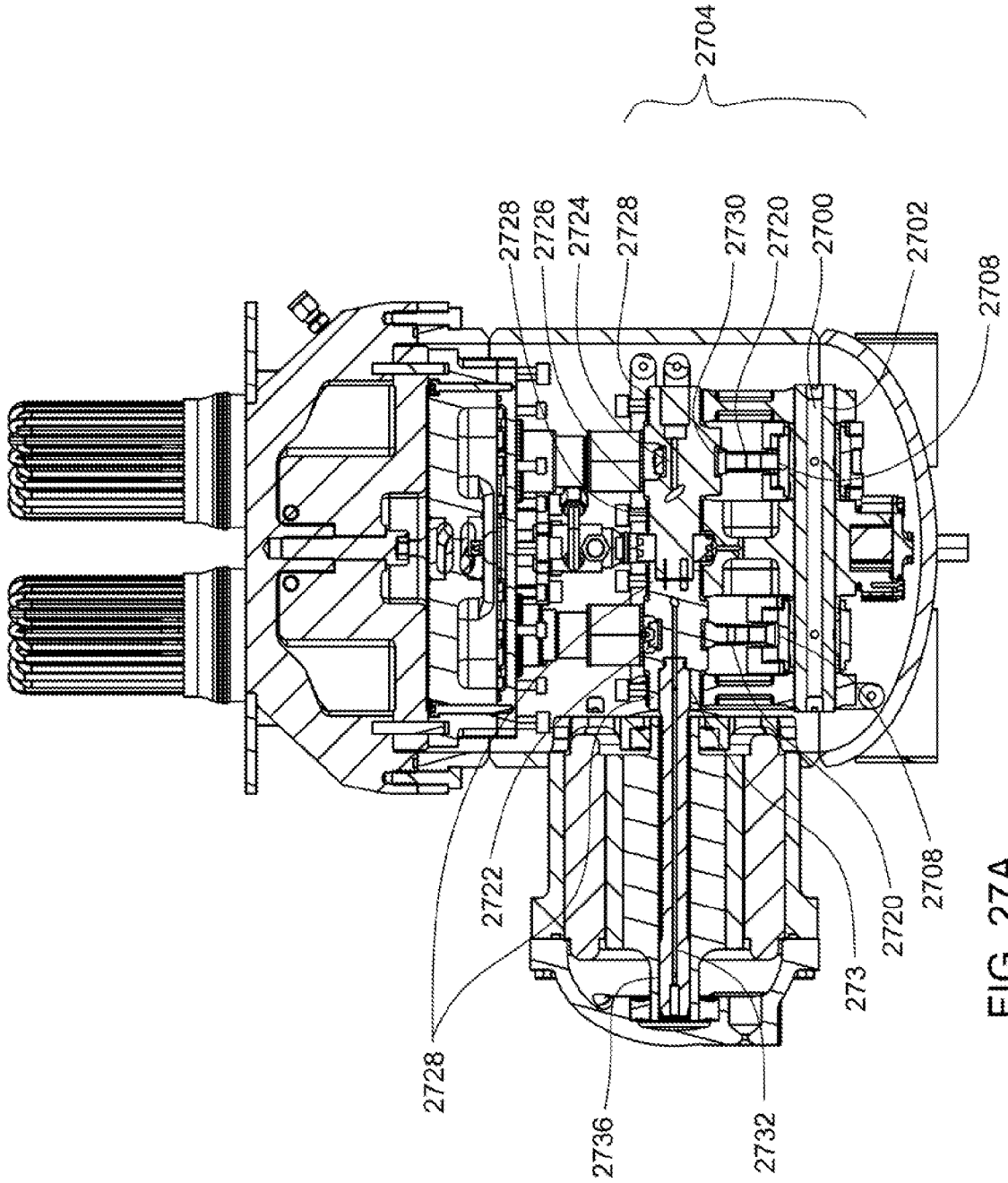

FIG. 27A

+

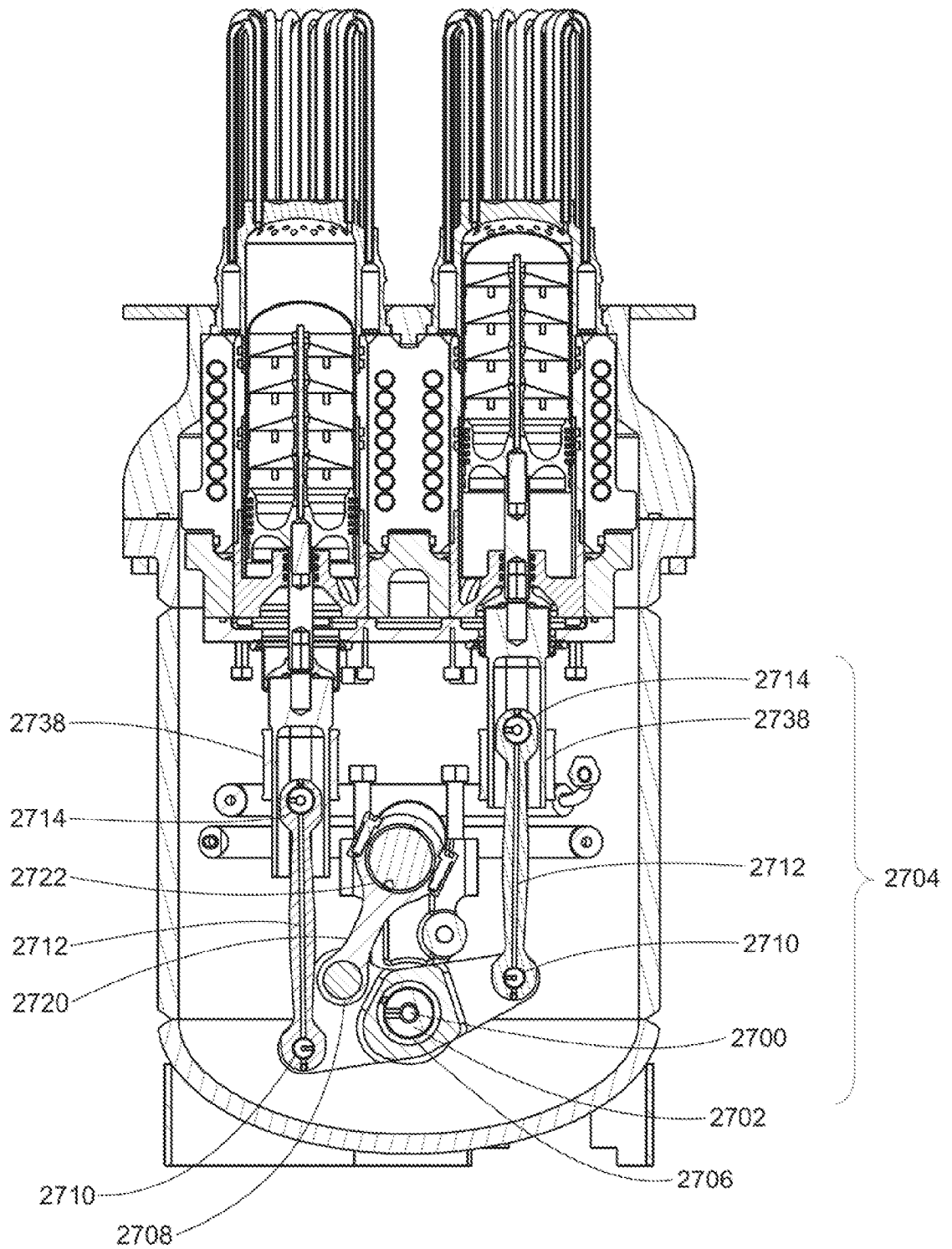

FIG. 27B

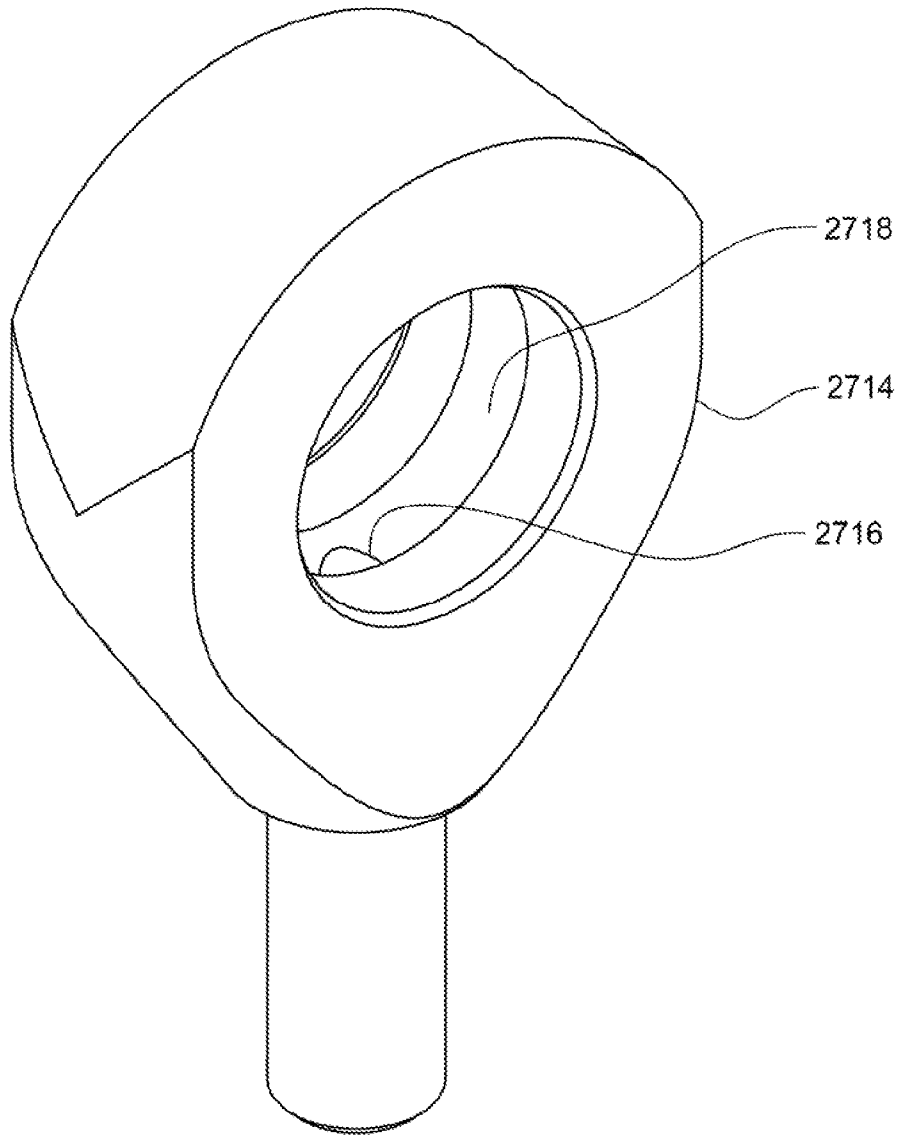

FIG. 27C

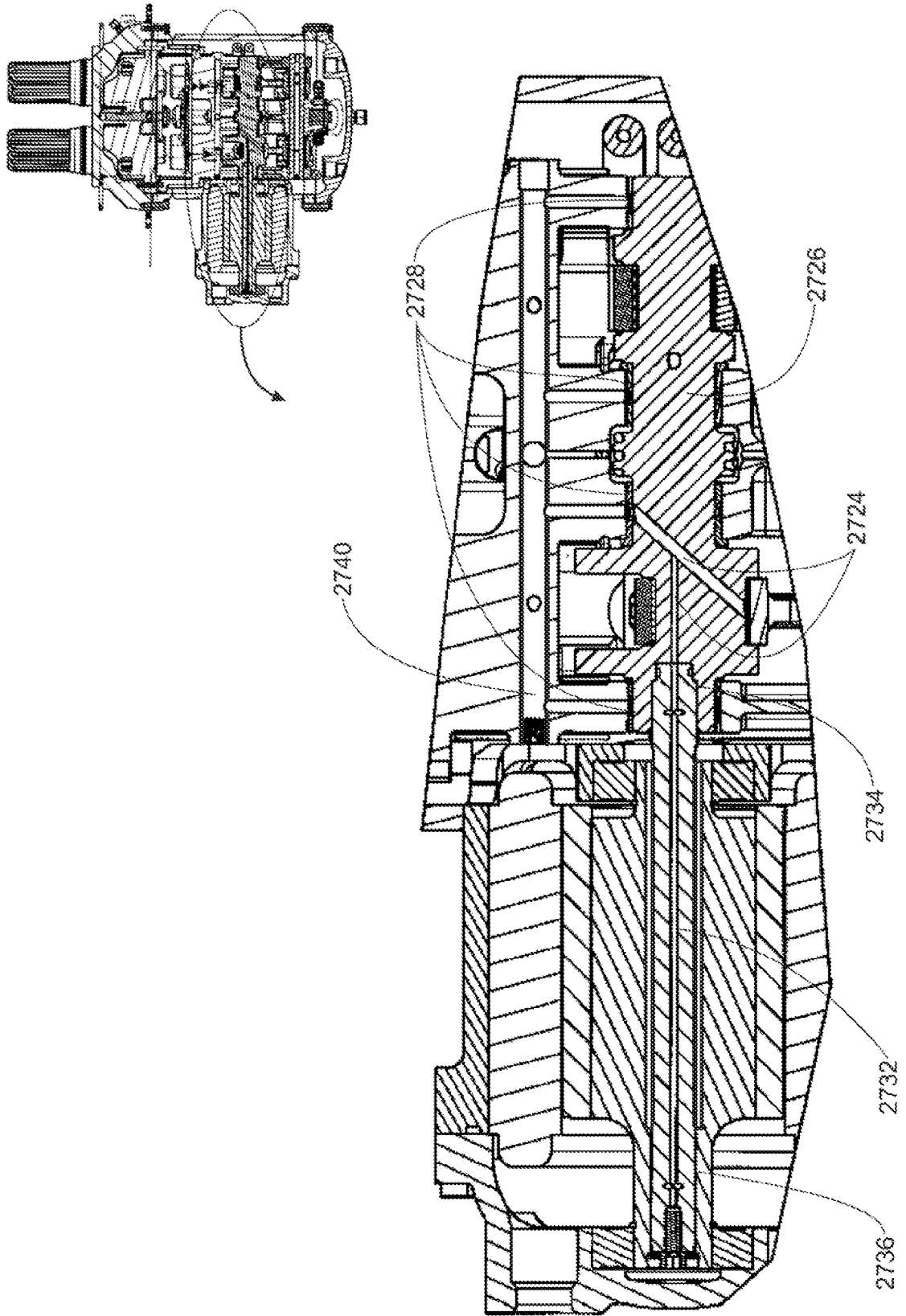

FIG. 27D

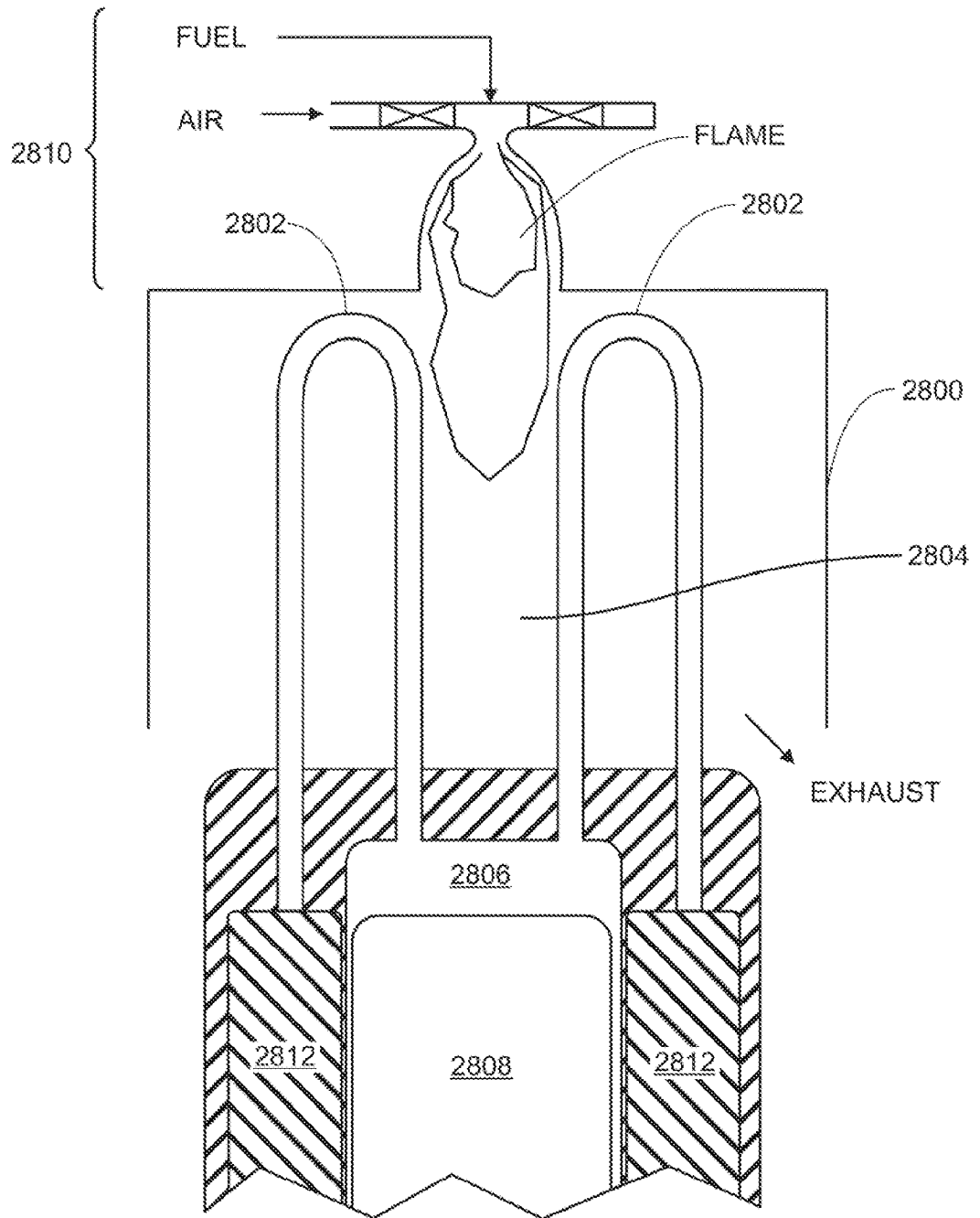

FIG. 28

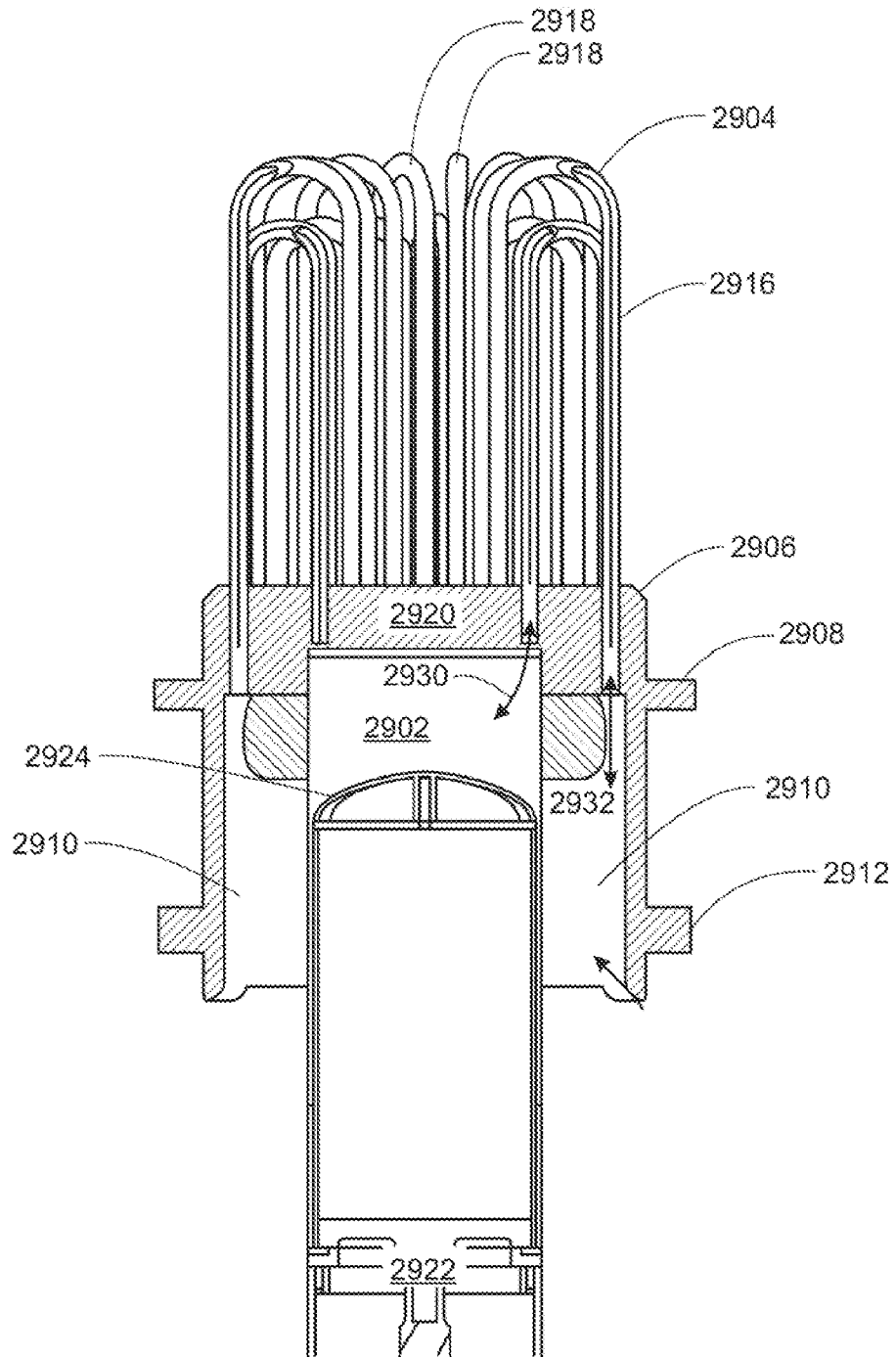

FIG.29

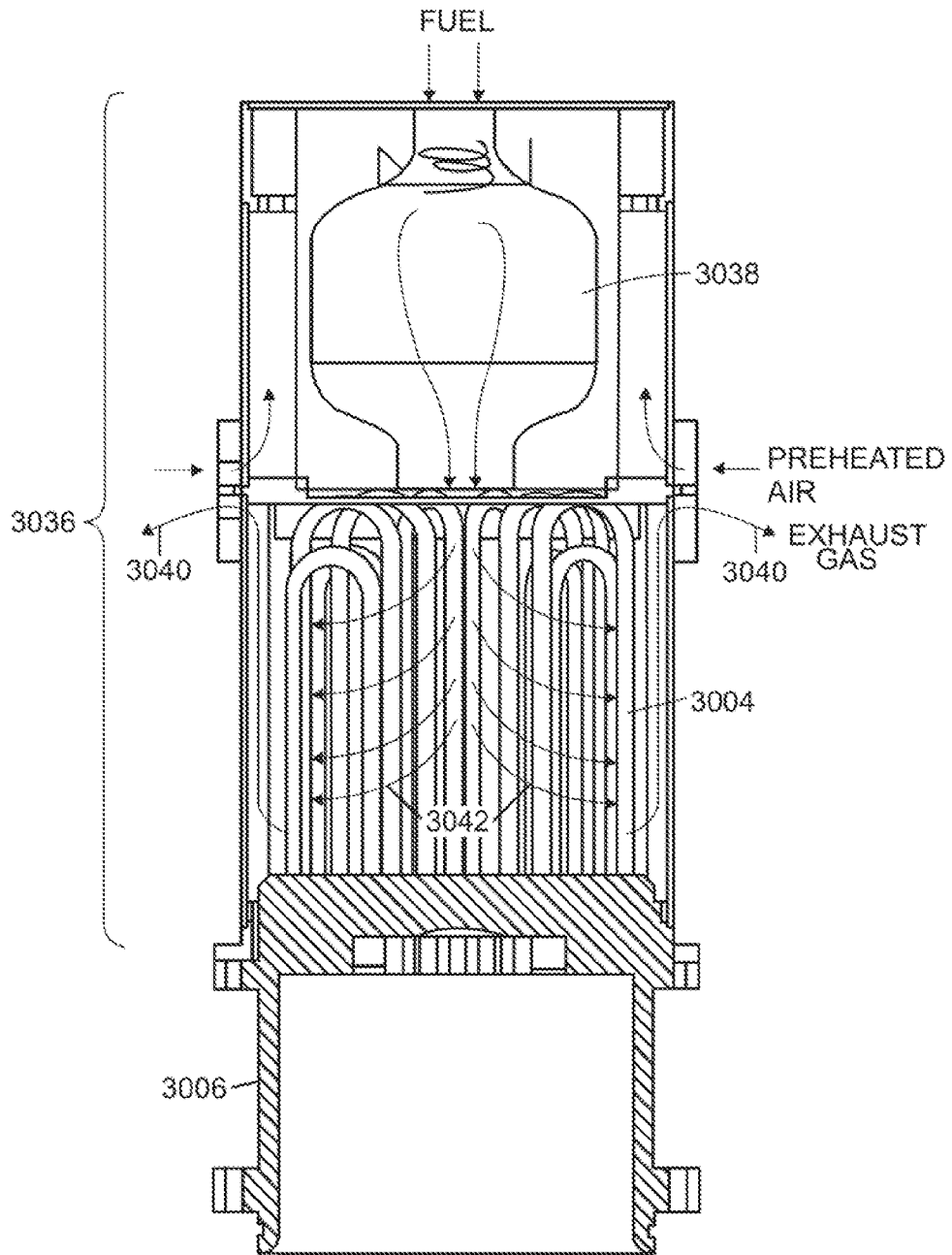

FIG.30

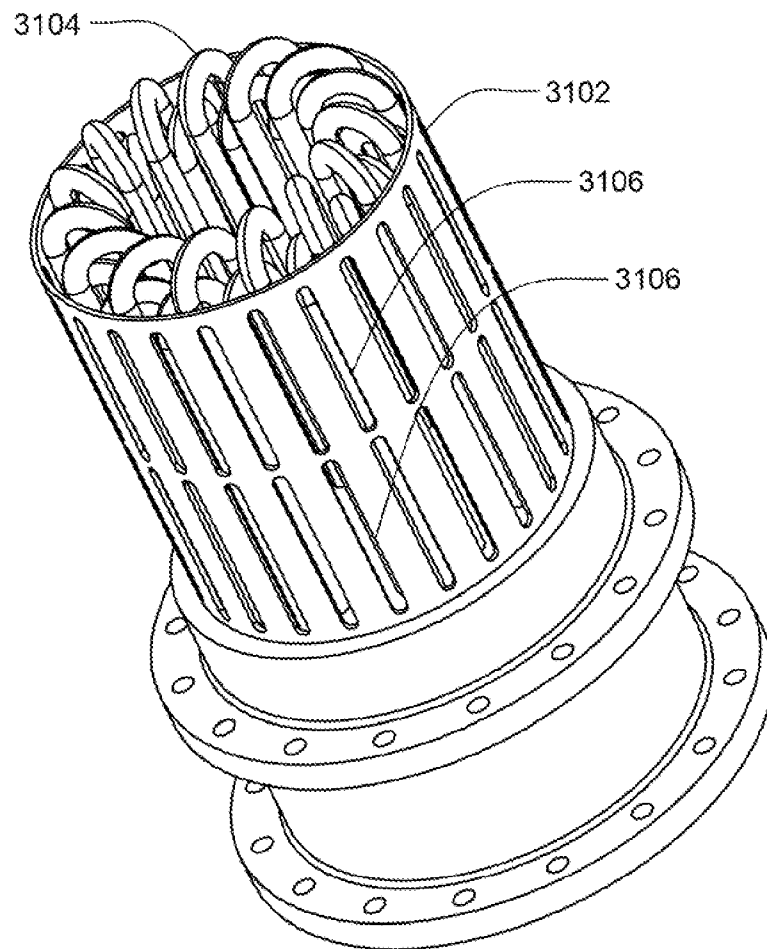

FIG. 31

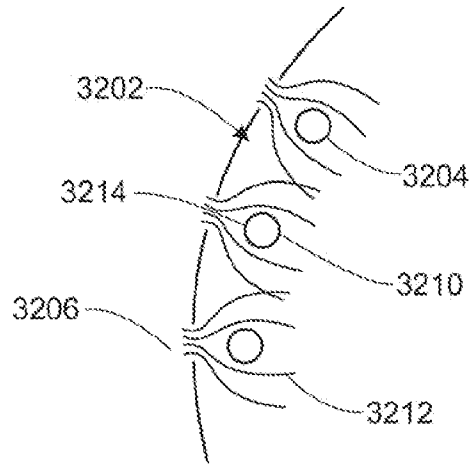

FIG.32

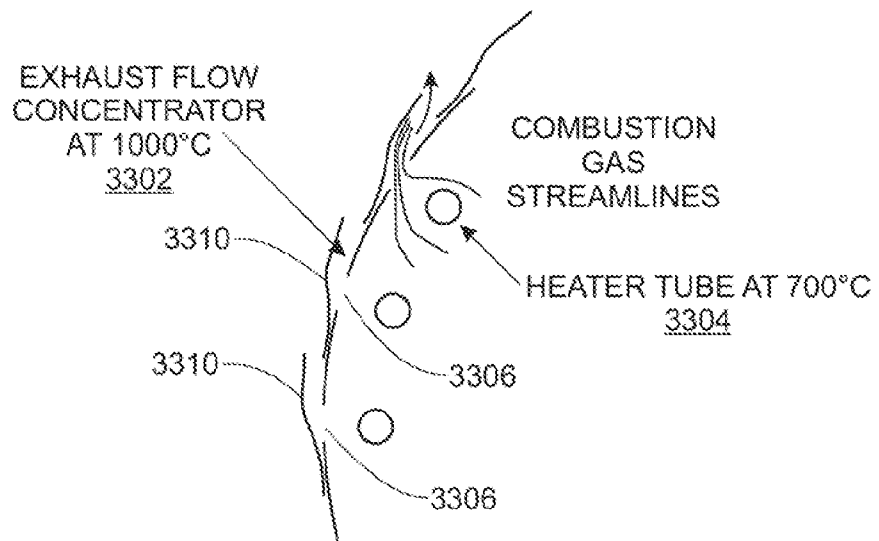

FIG.33

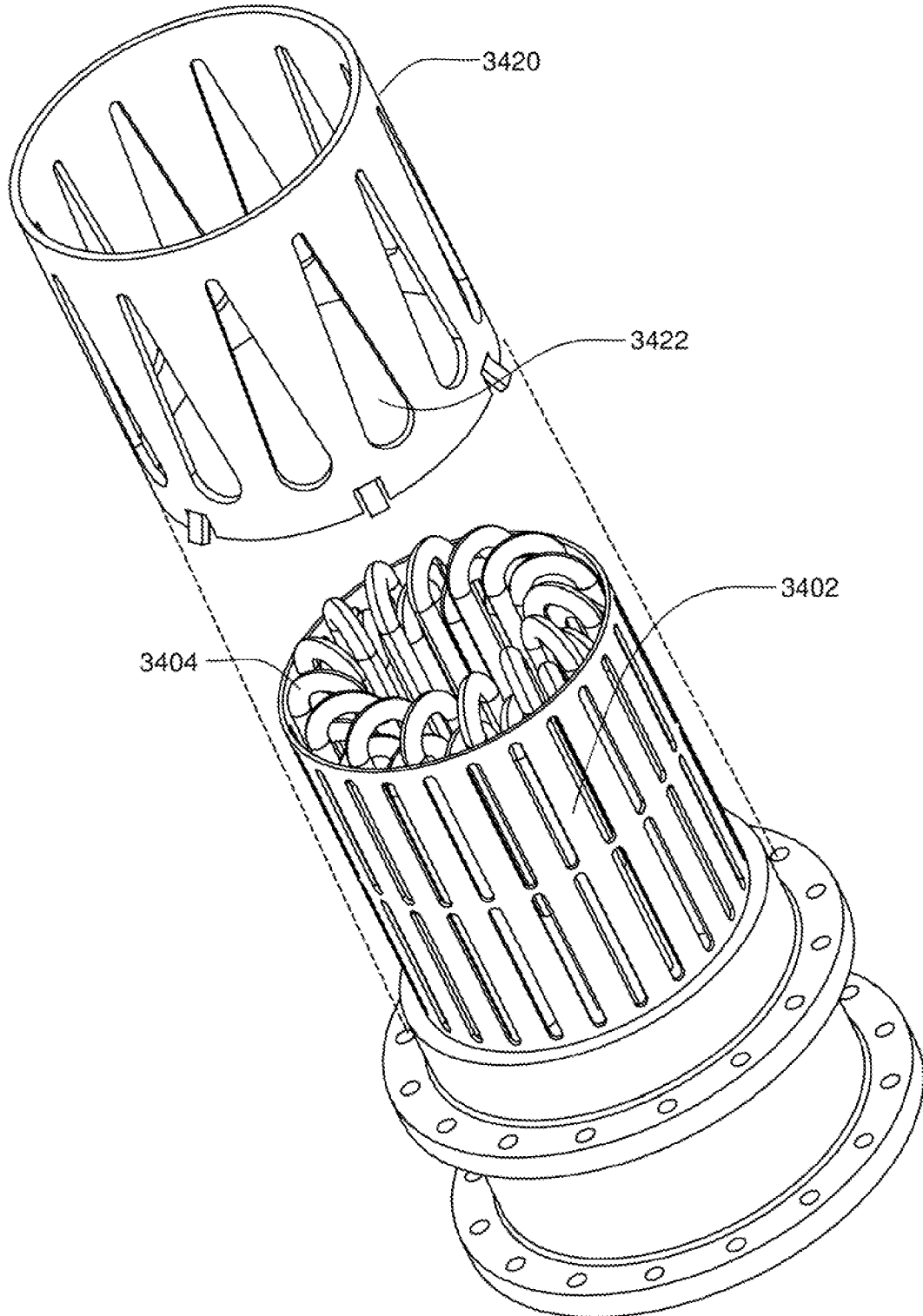

FIG. 34

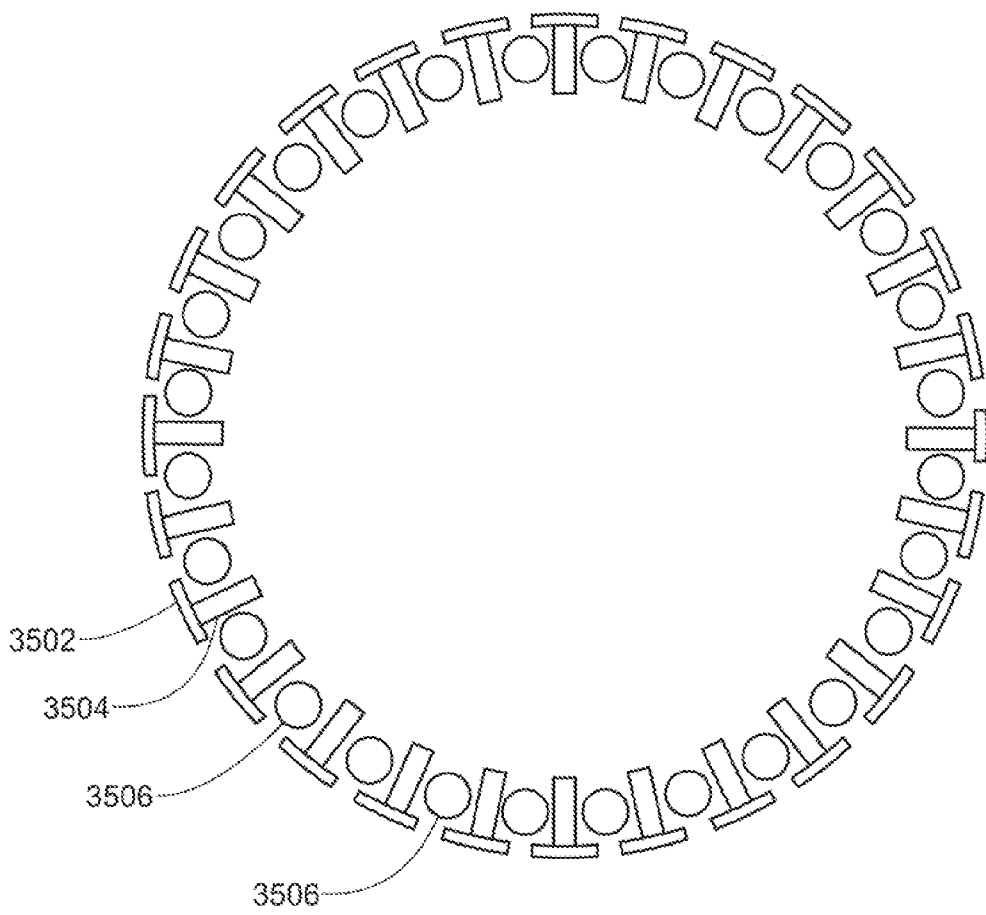

FIG.35

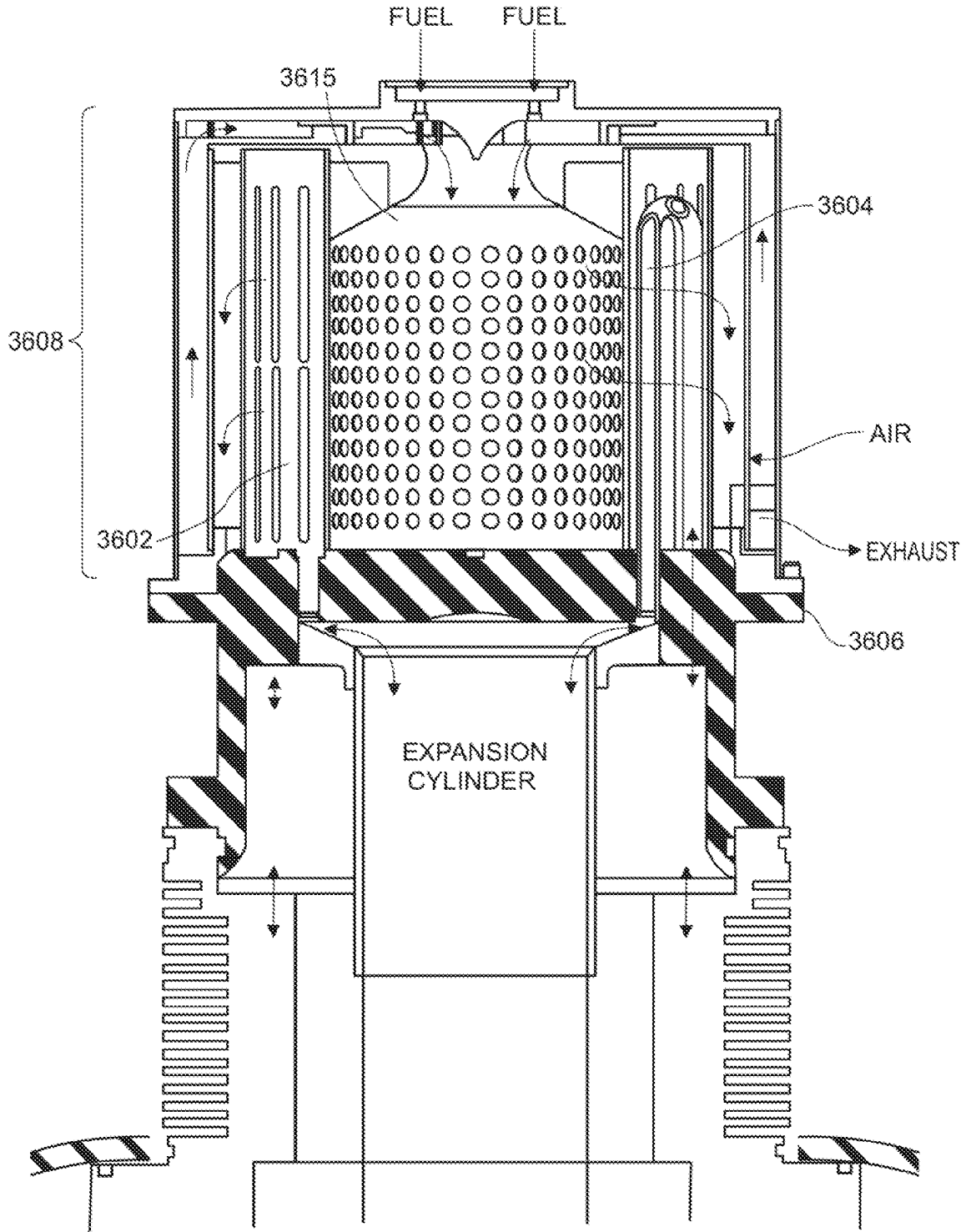

FIG. 36

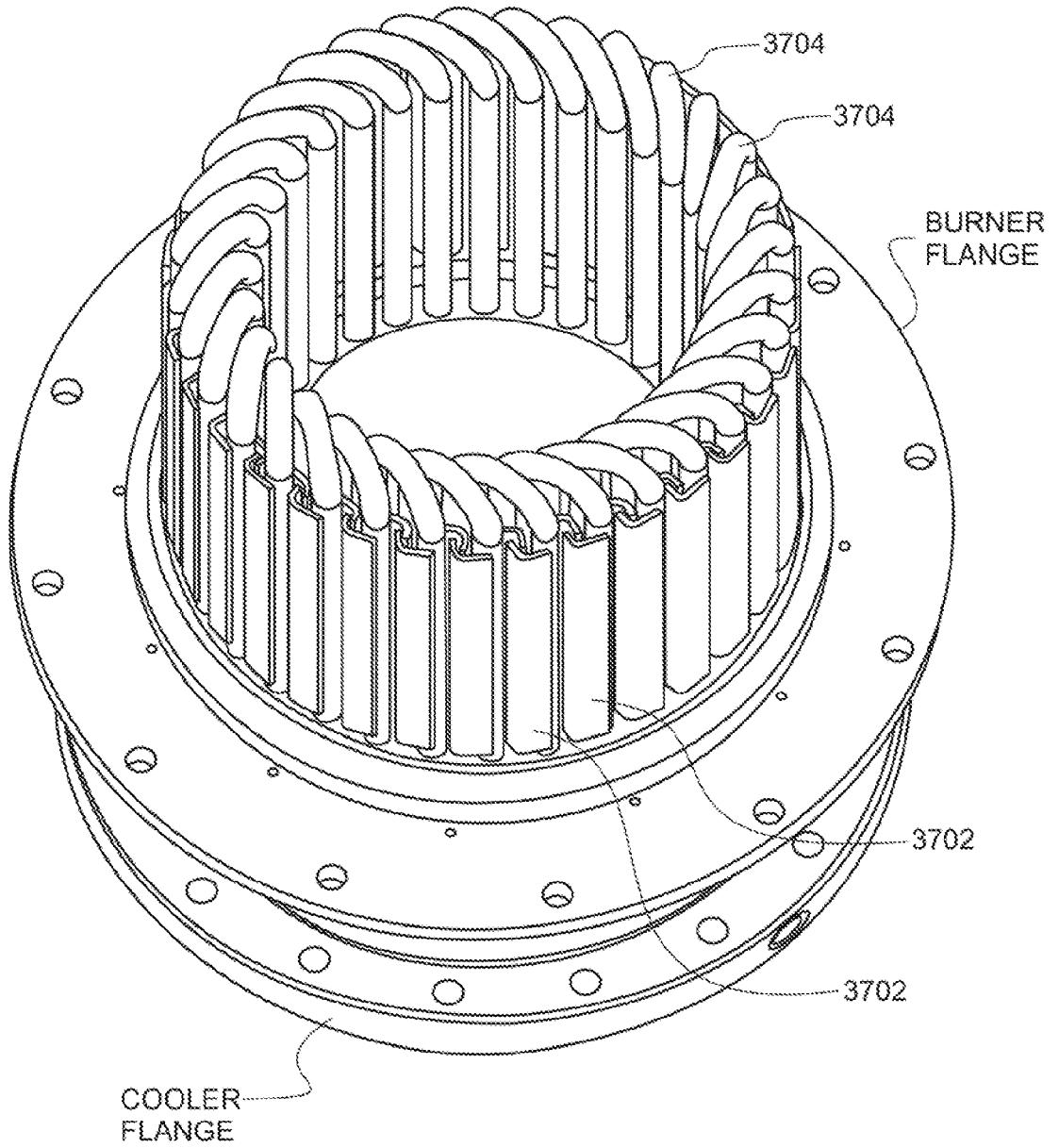

FIG. 37

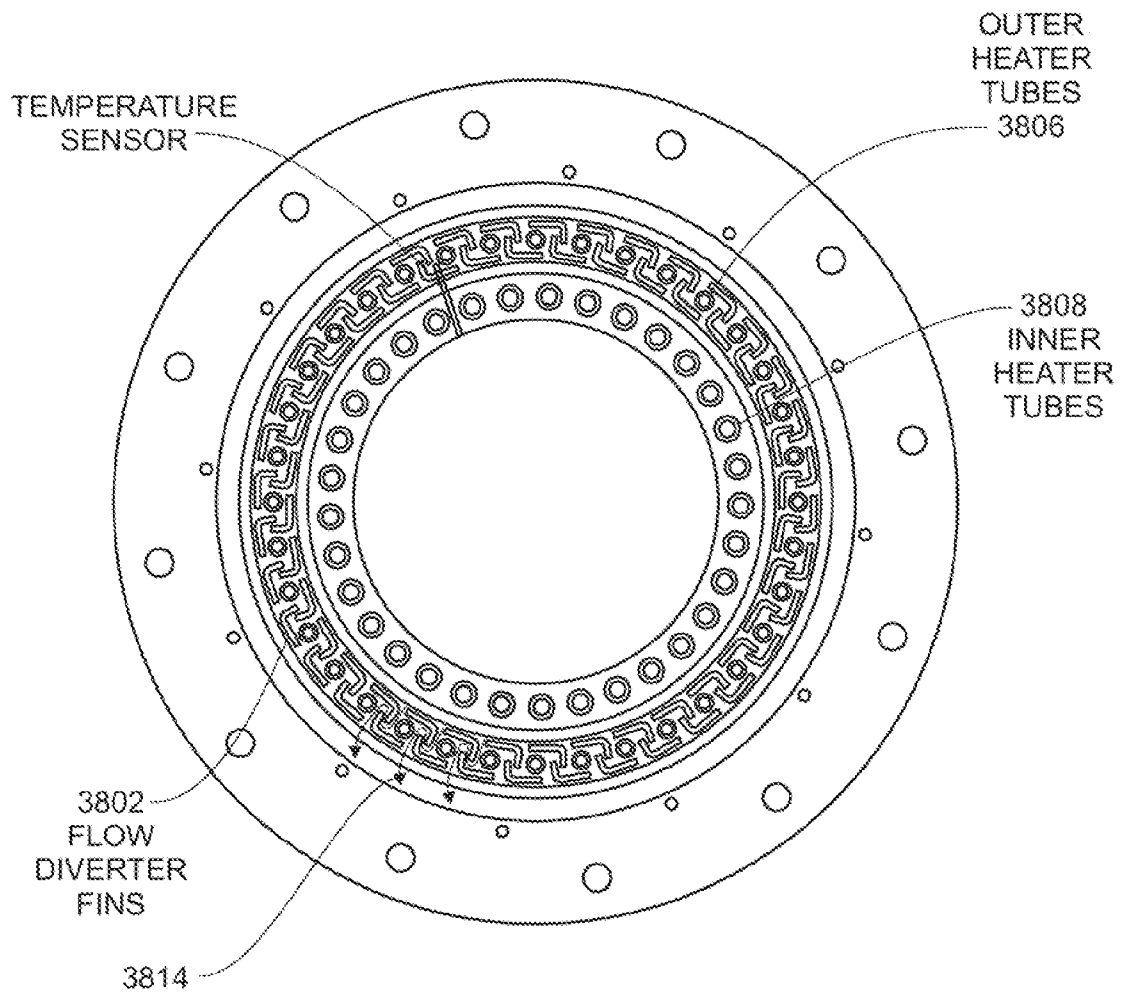

FIG. 38

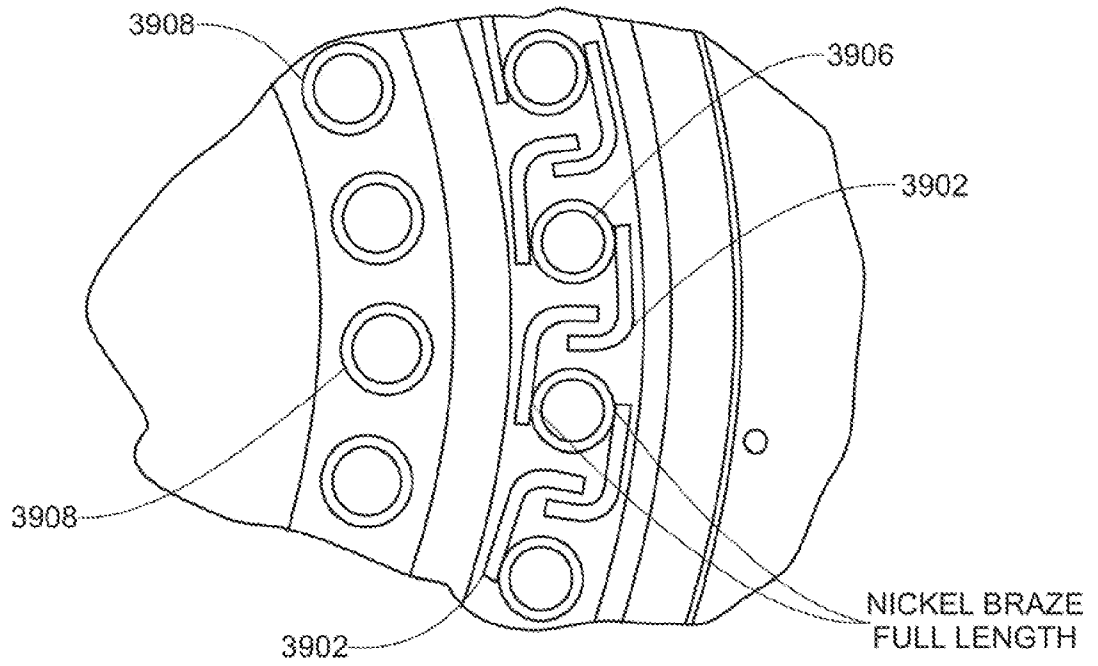

FIG. 39

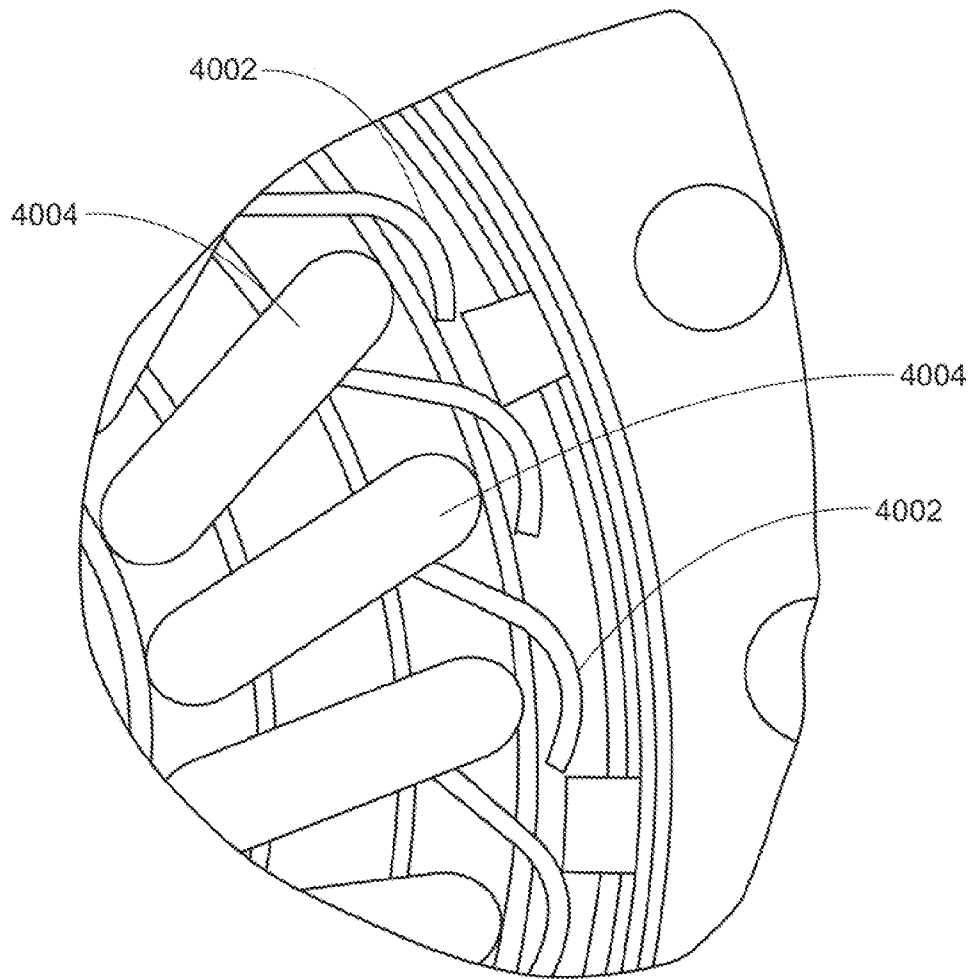

FIG.40

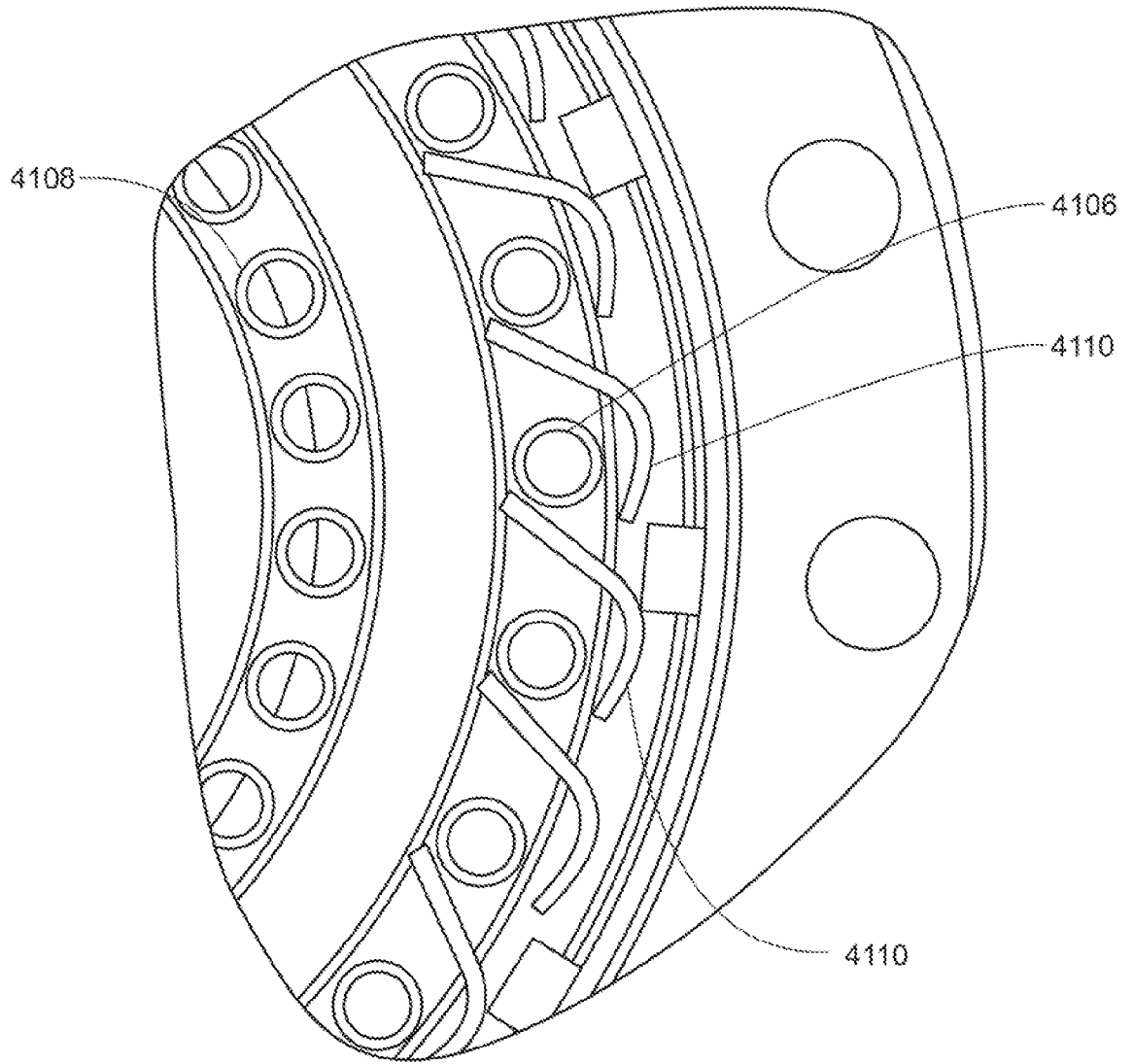

FIG.41

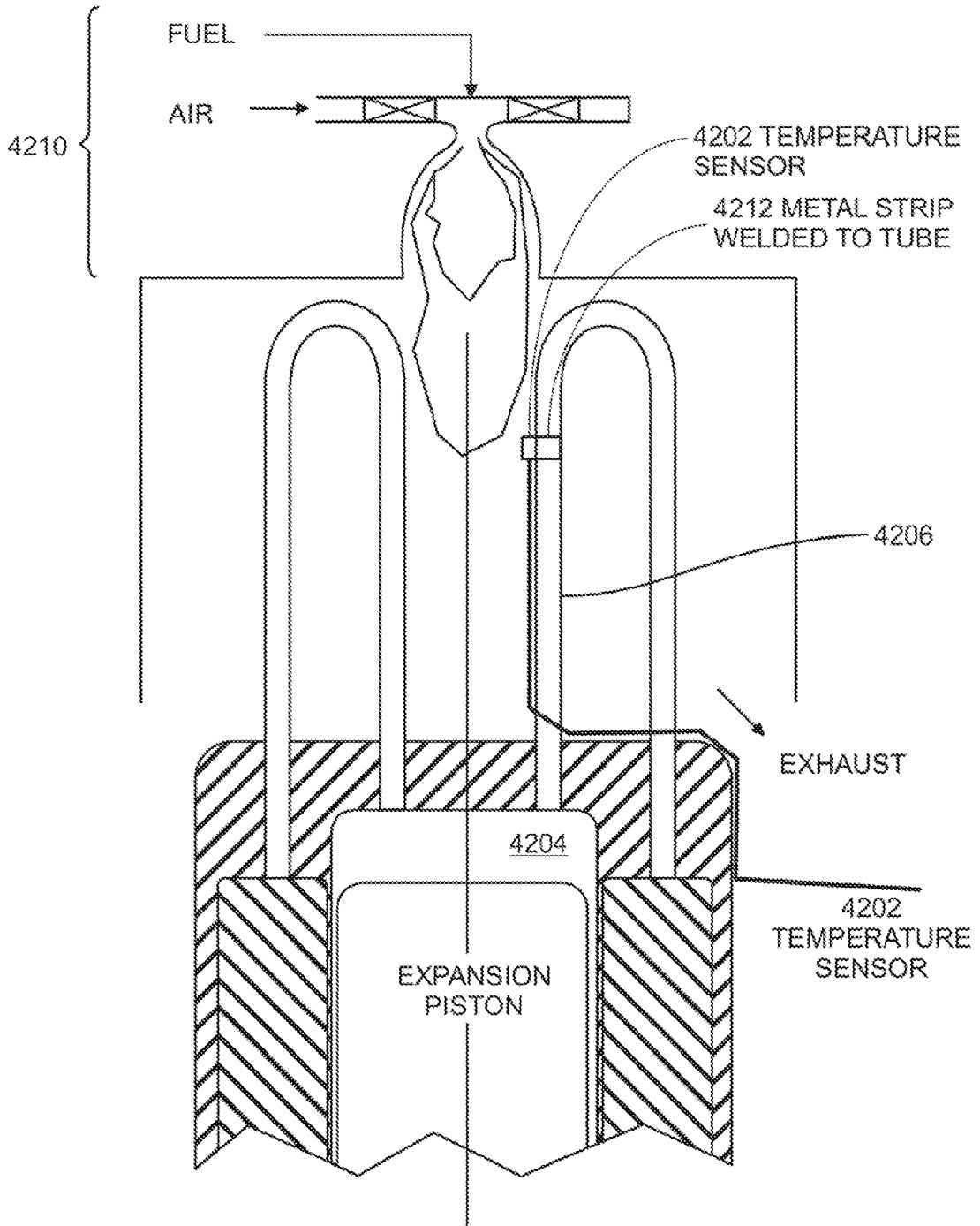

FIG.42

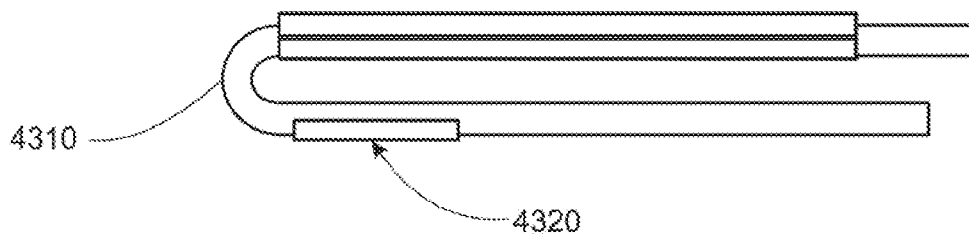

FIG. 43A

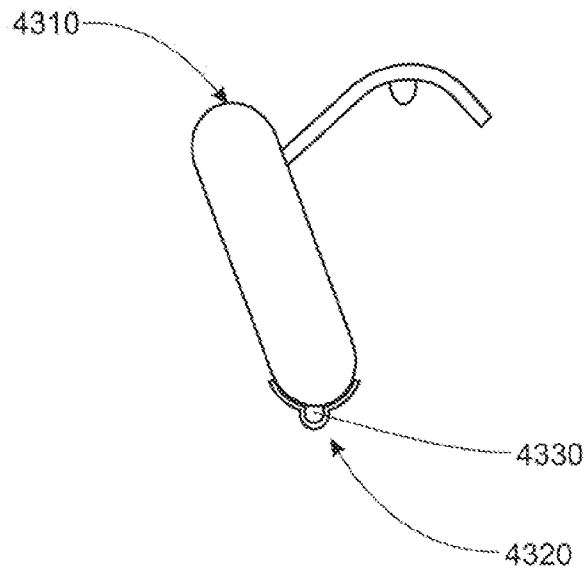

FIG. 43B

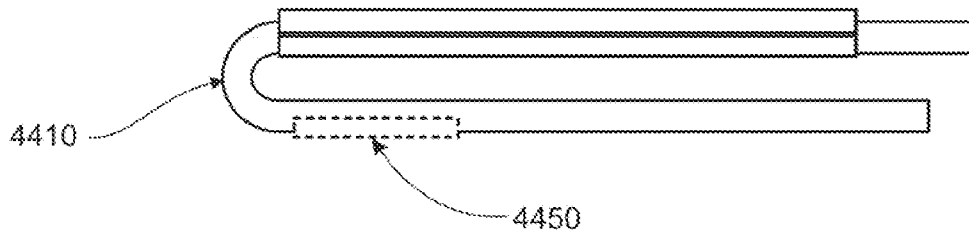

FIG. 44A

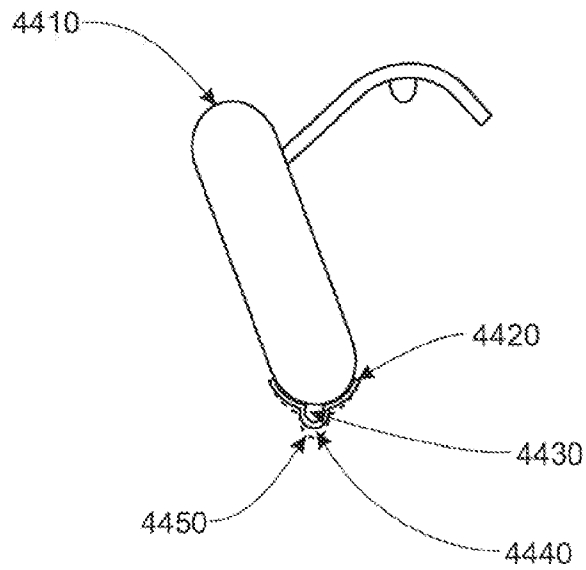

FIG. 44B

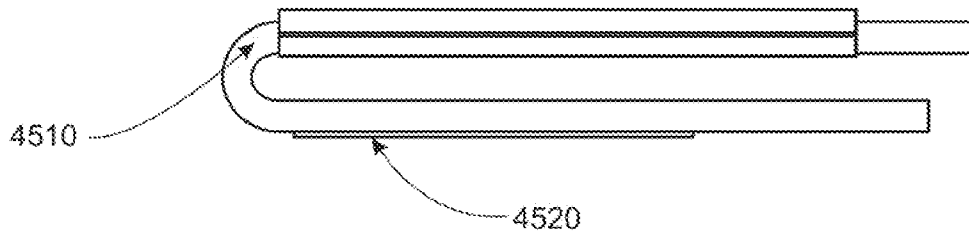

FIG. 45A

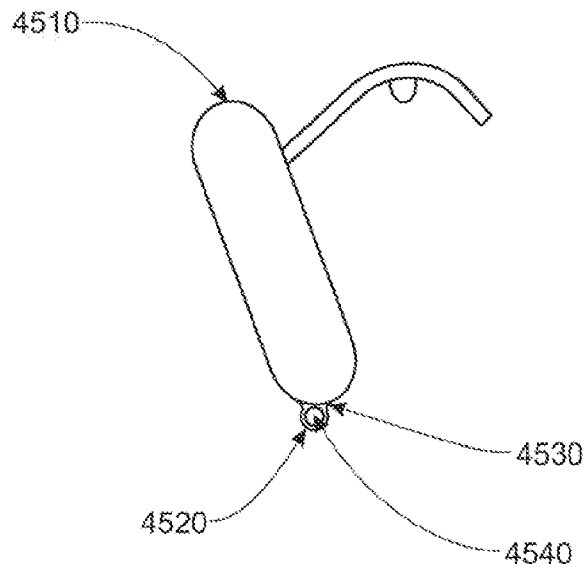

FIG. 45B

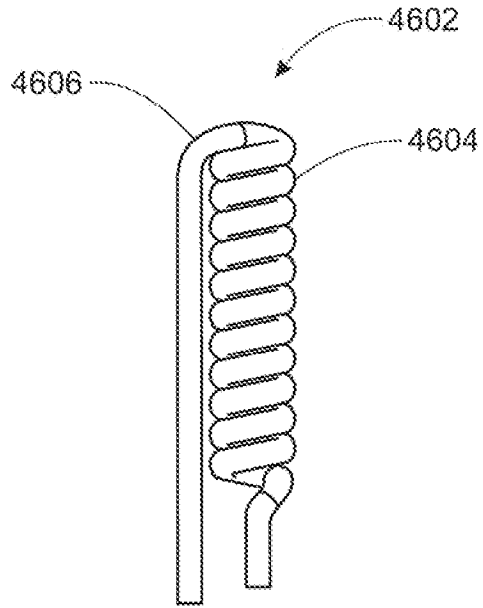

FIG. 46A



FIG. 46B

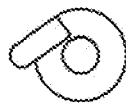

FIG. 46C

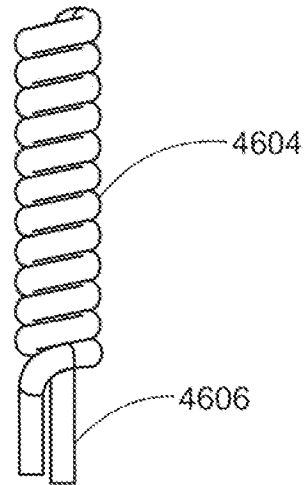

FIG. 46D

ILLUSTRATION: DOUBLE HELIX HEATER HEAD TUBING

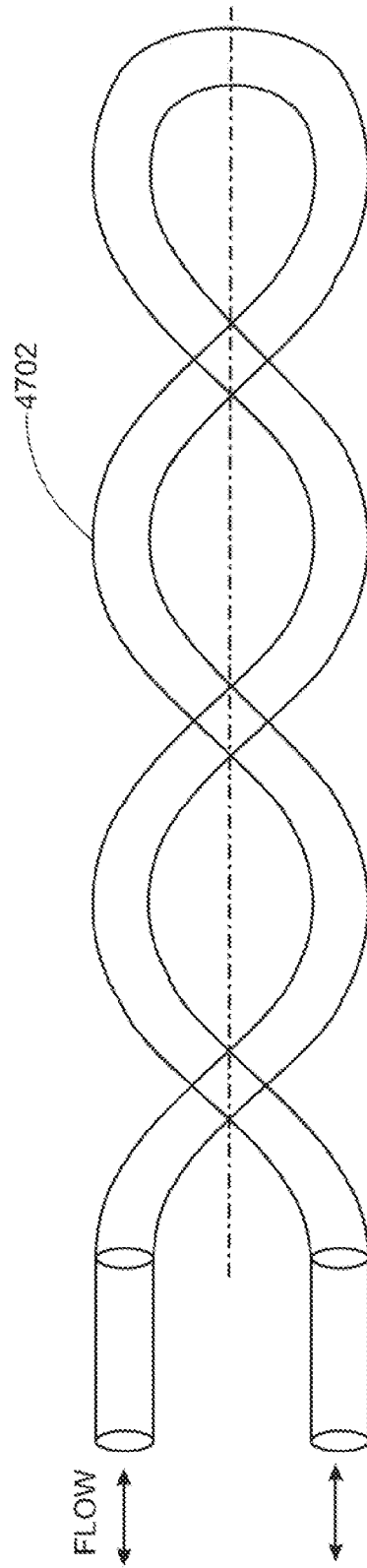

FIG. 47

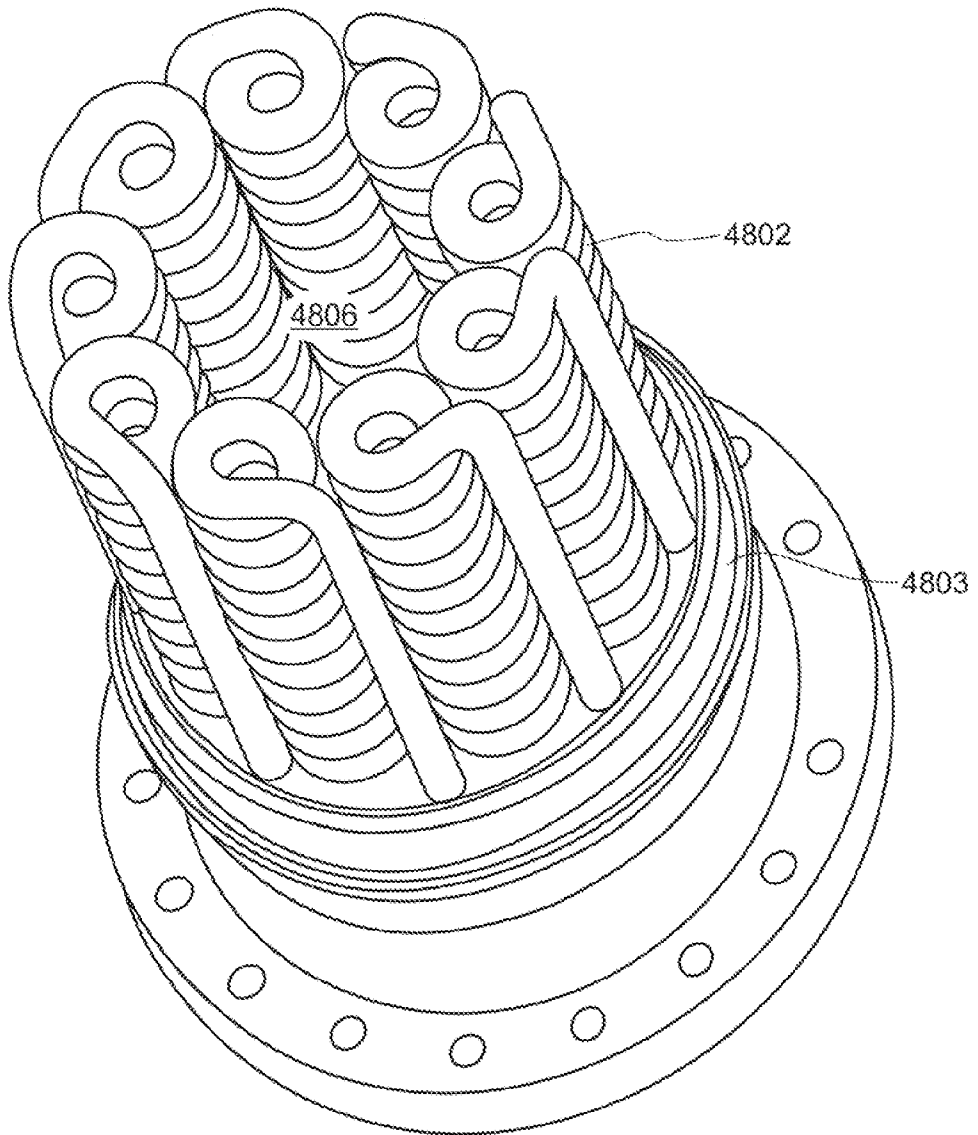

FIG. 48

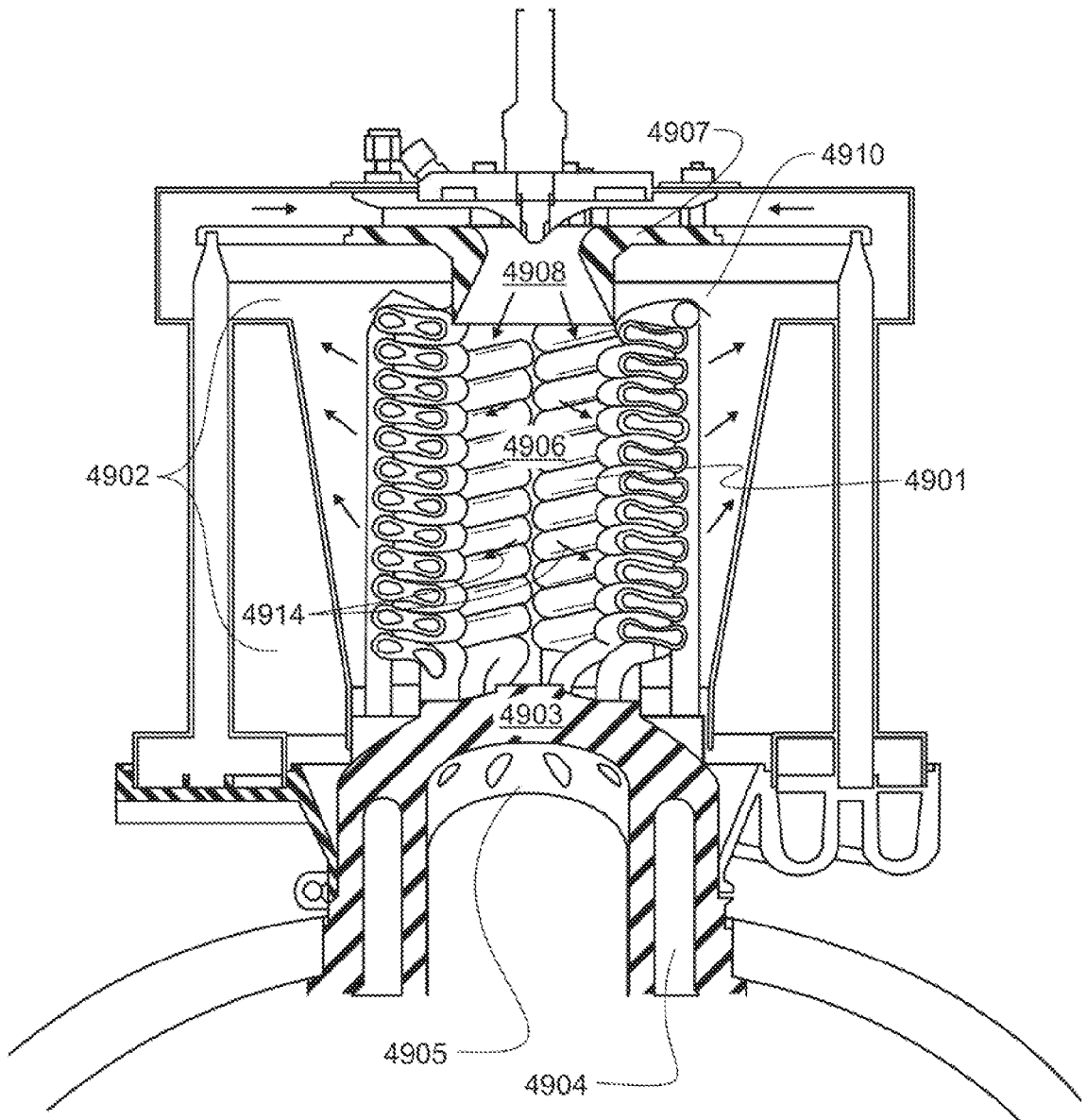

FIG. 49

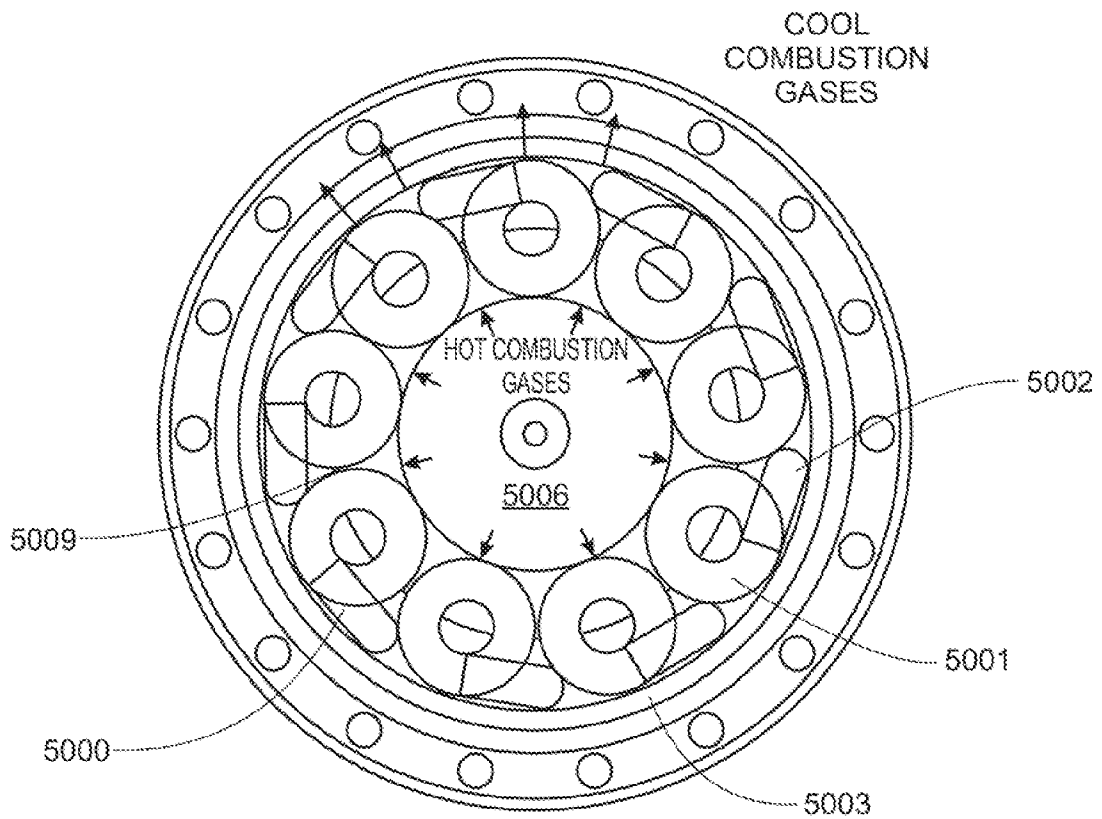

FIG. 50

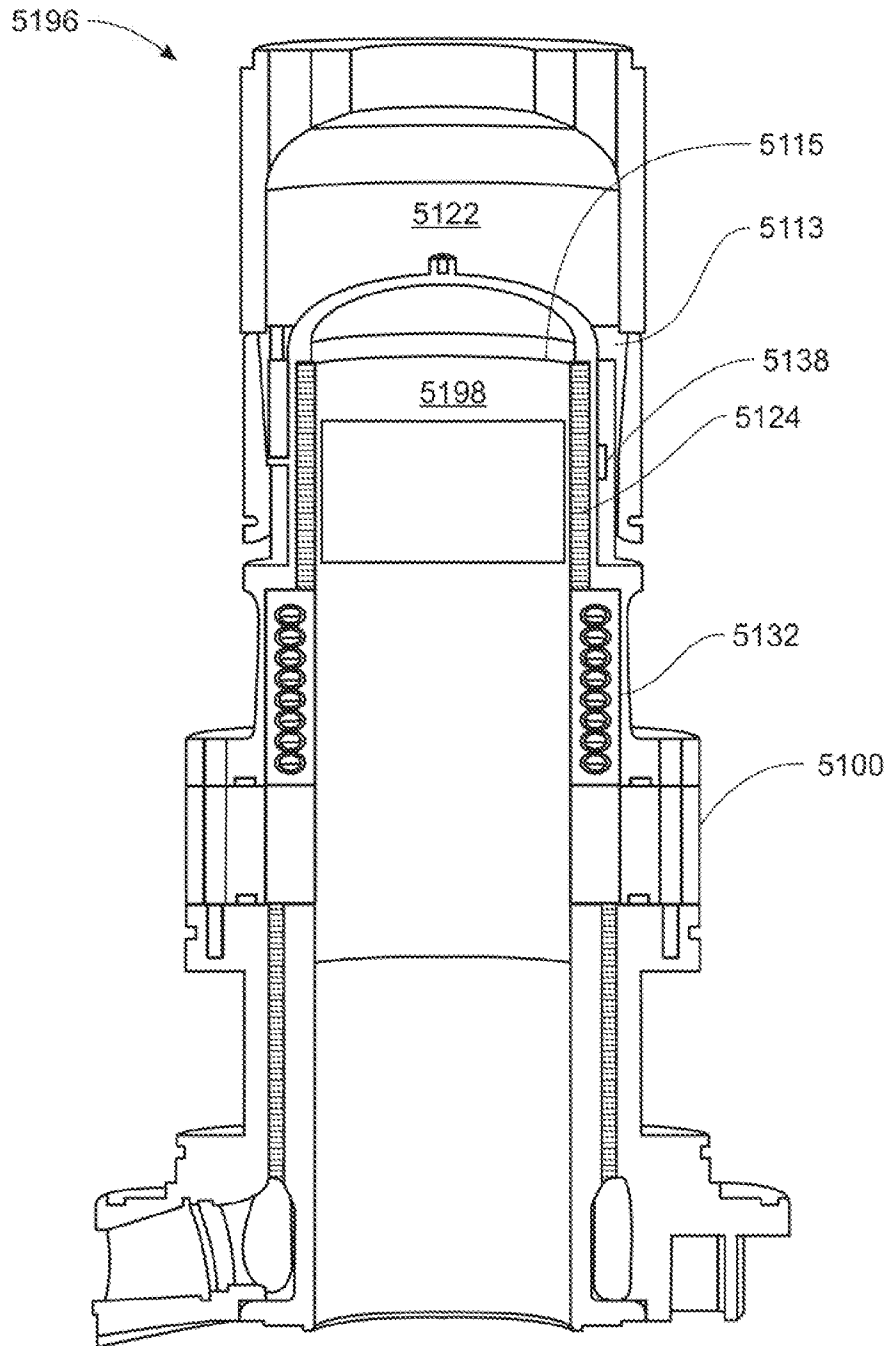

FIG. 51A

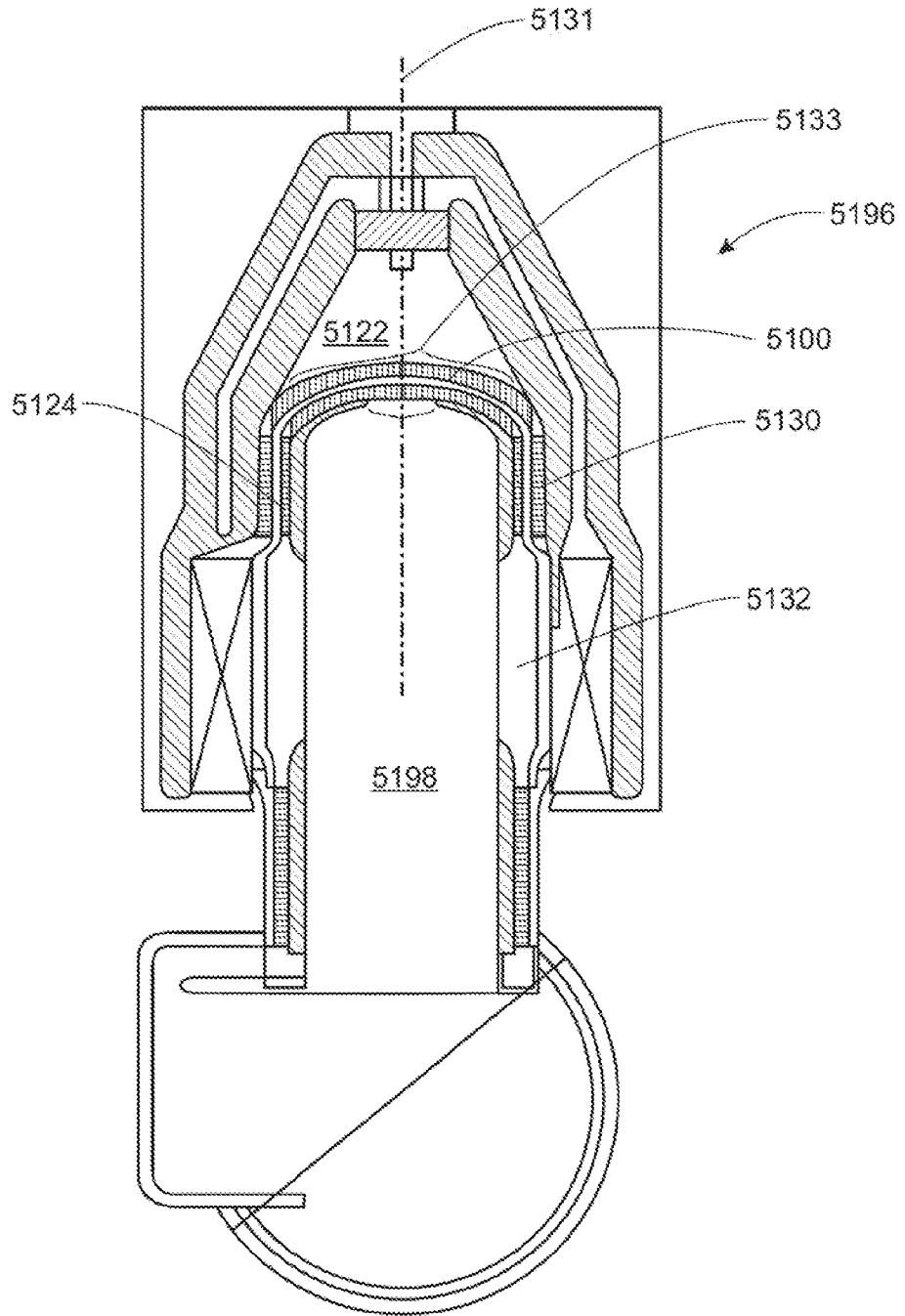

FIG. 51B

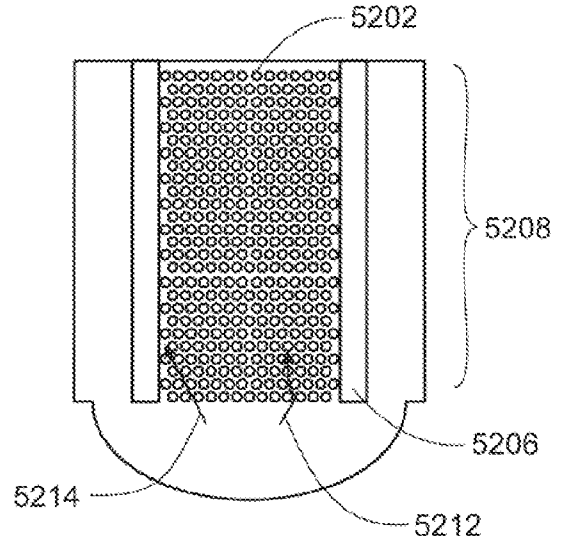

FIG. 52A

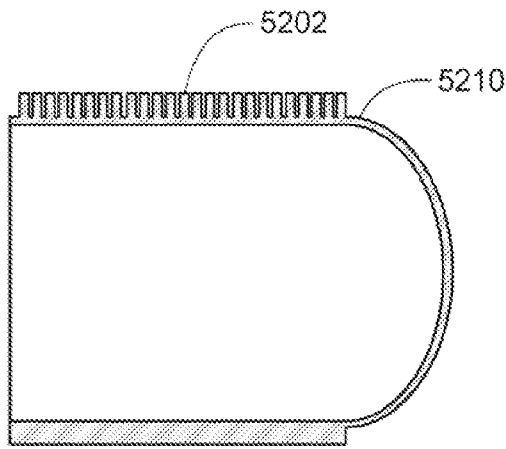

FIG. 52B

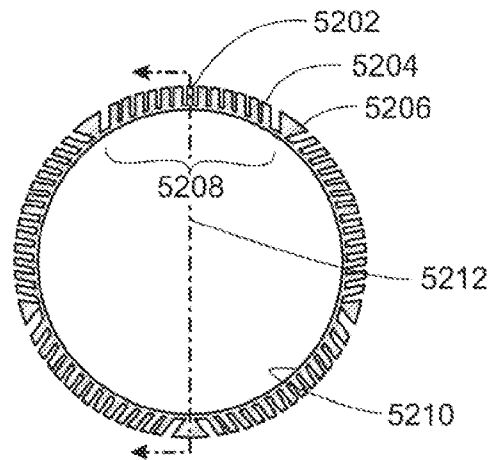

FIG. 52C

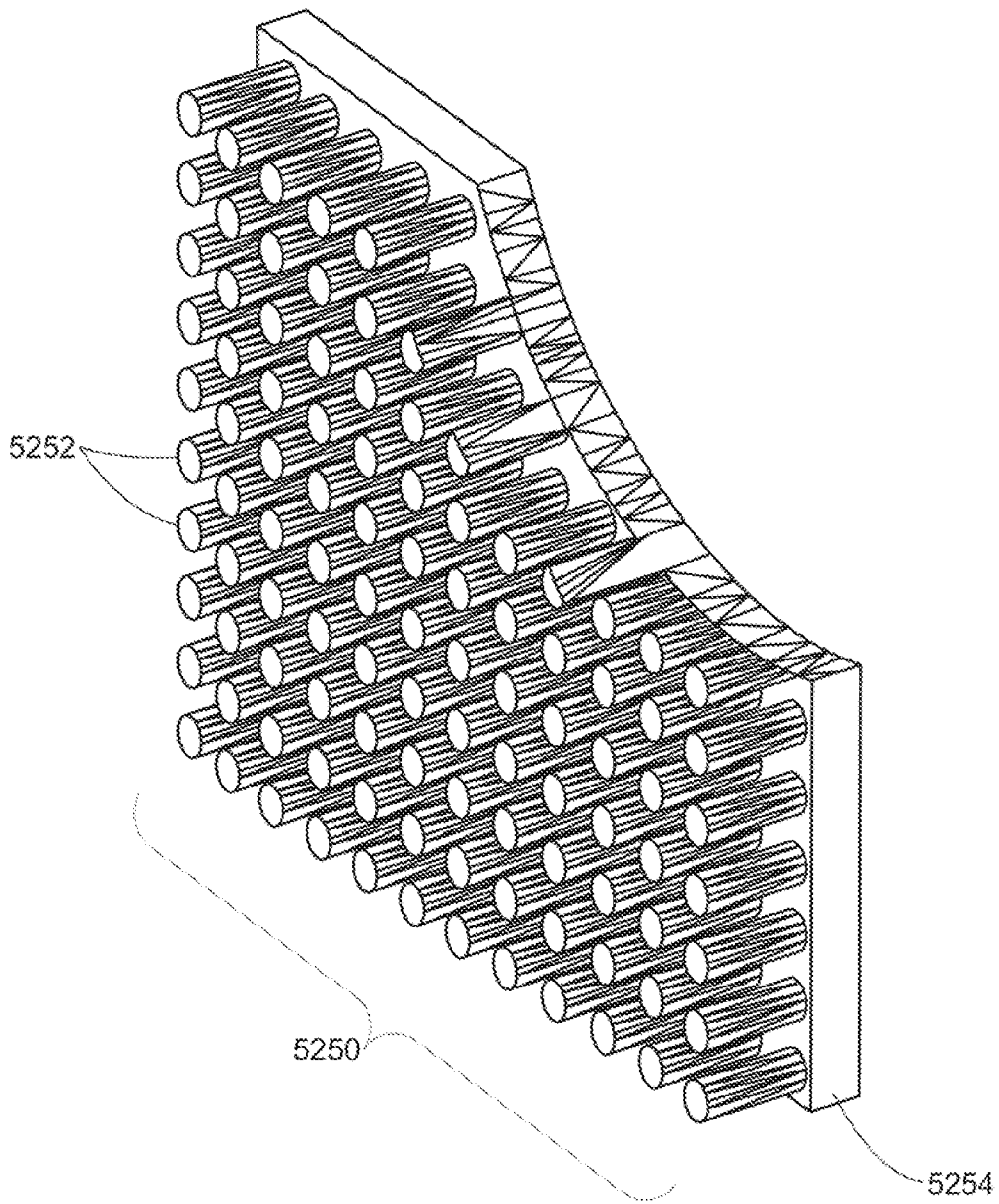

FIG. 52D

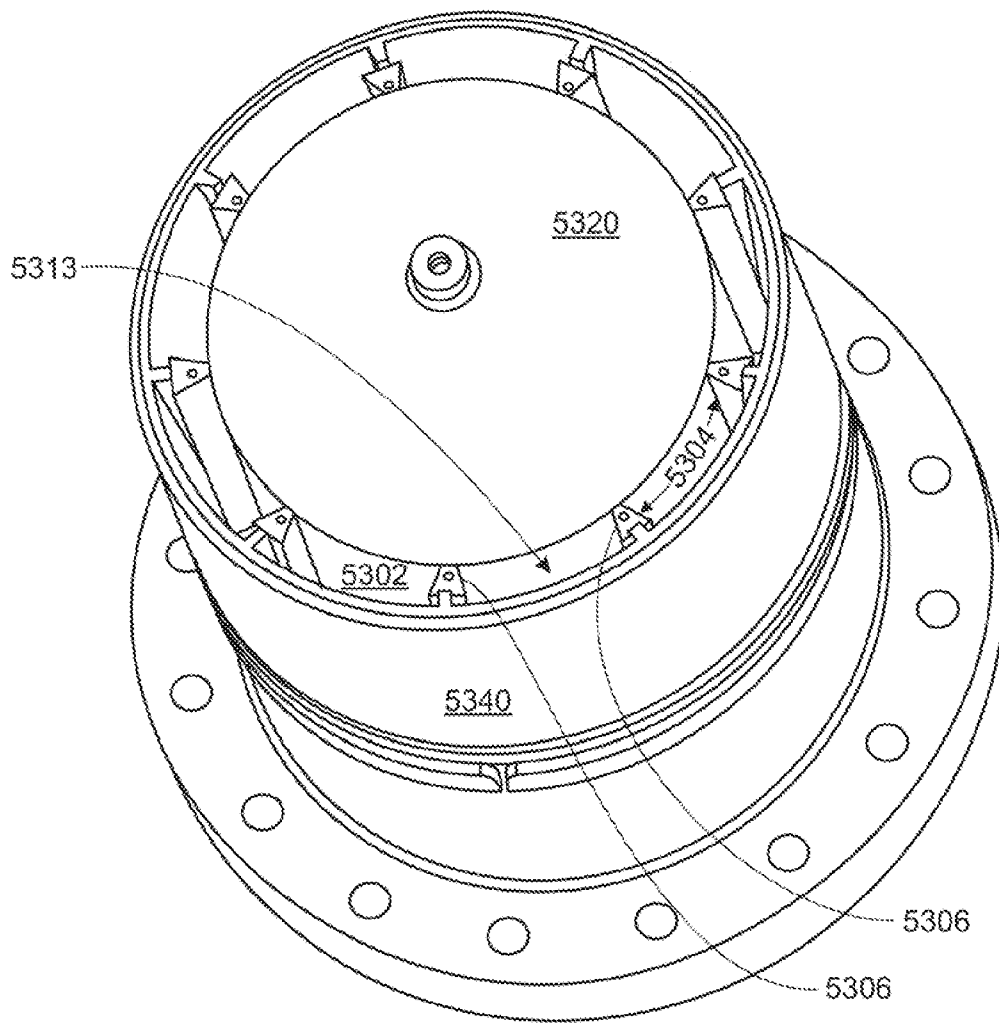

FIG. 53A

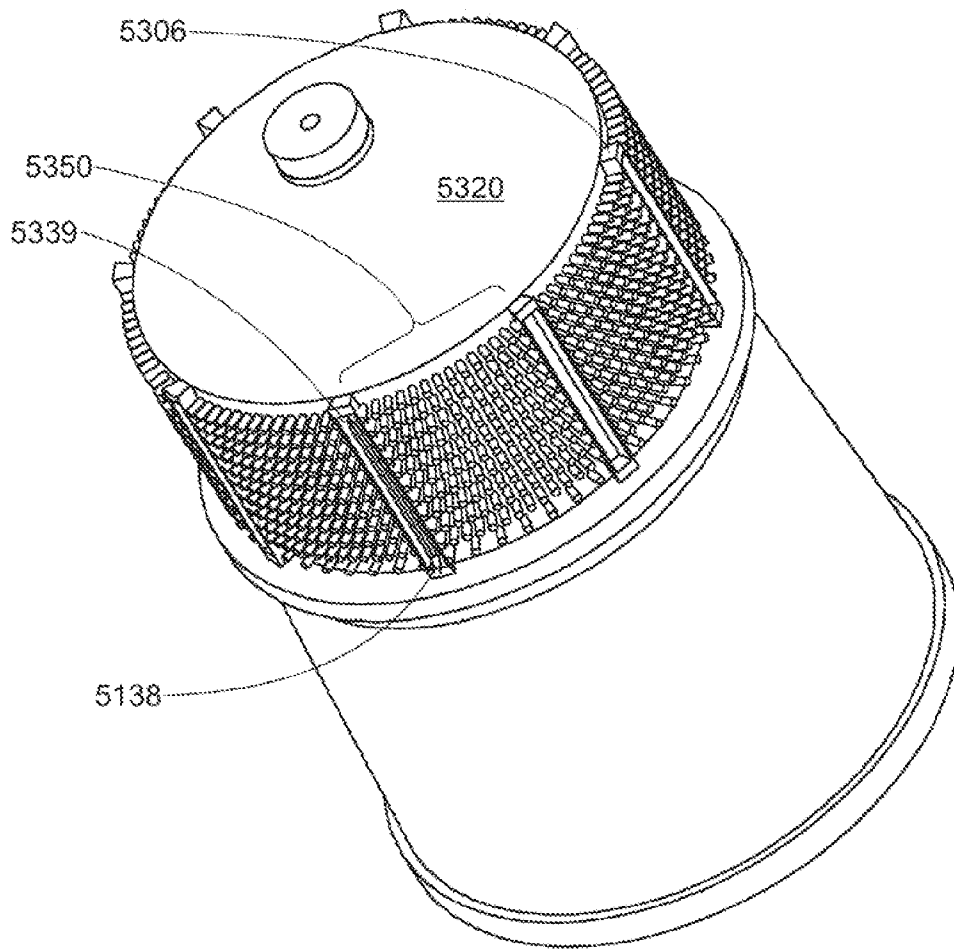

FIG. 53B

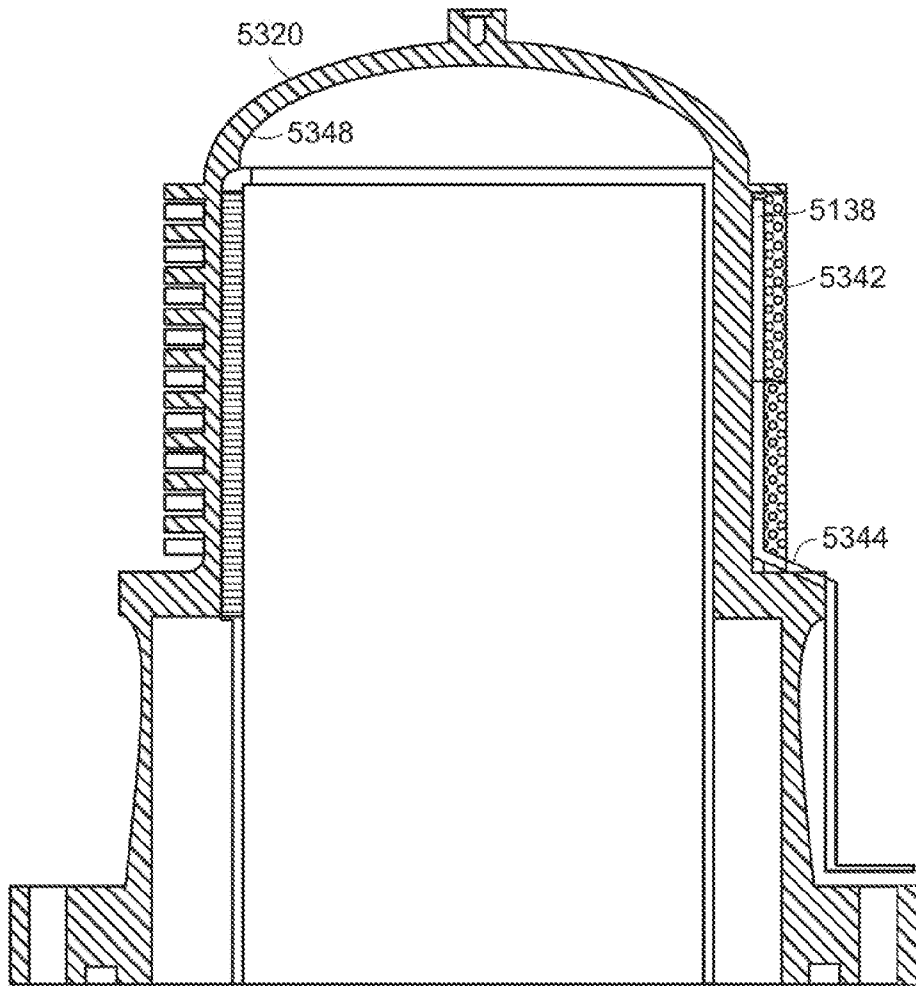

FIG. 53C

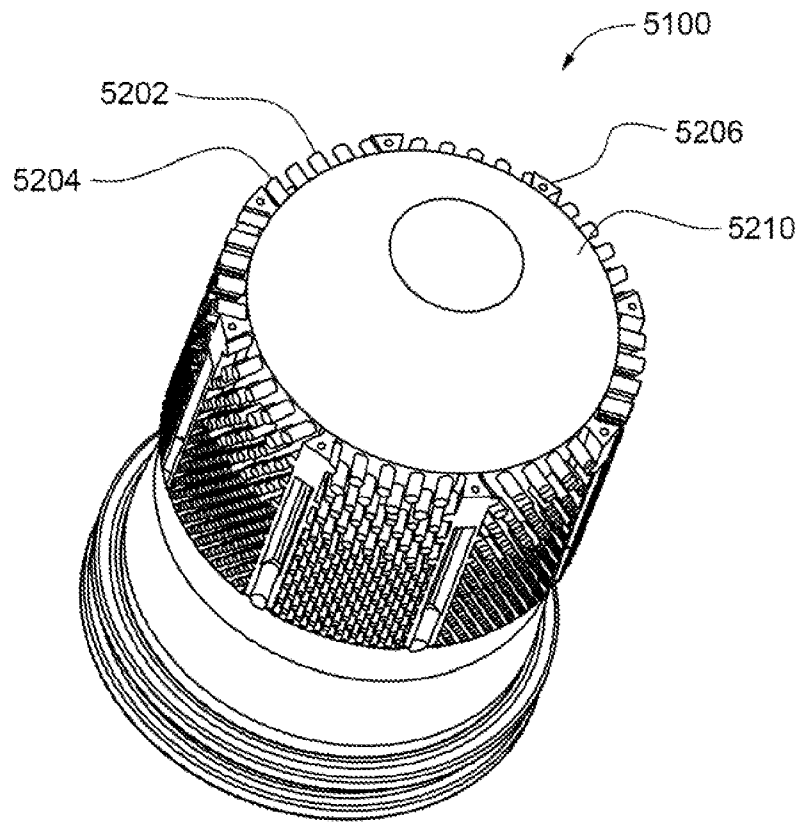

FIG. 53D

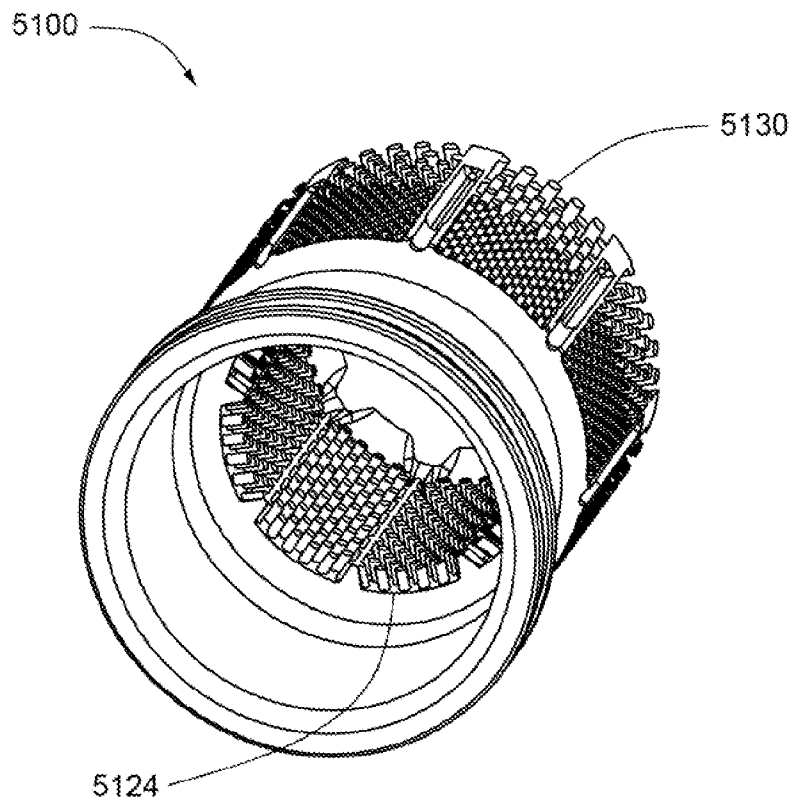

FIG. 53E

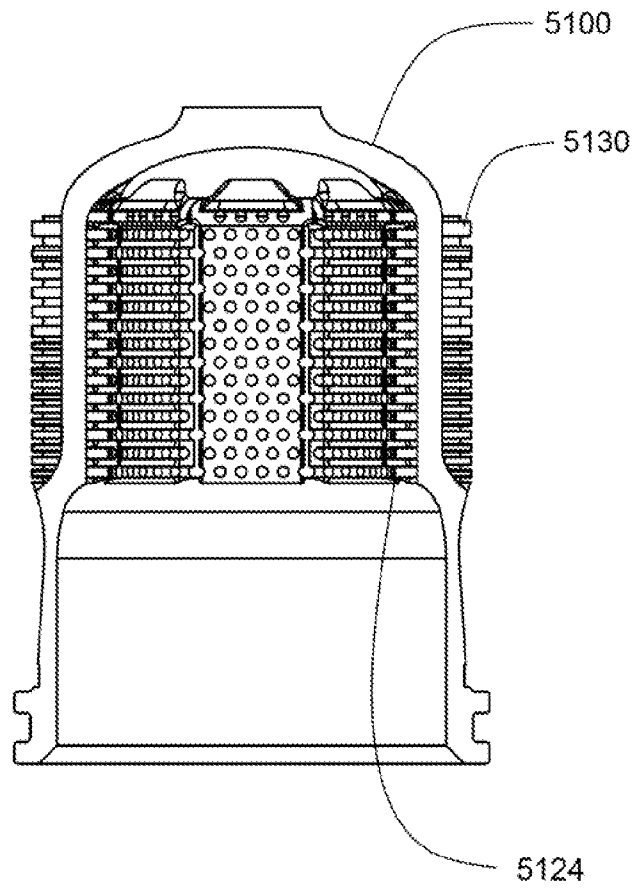

FIG. 53F

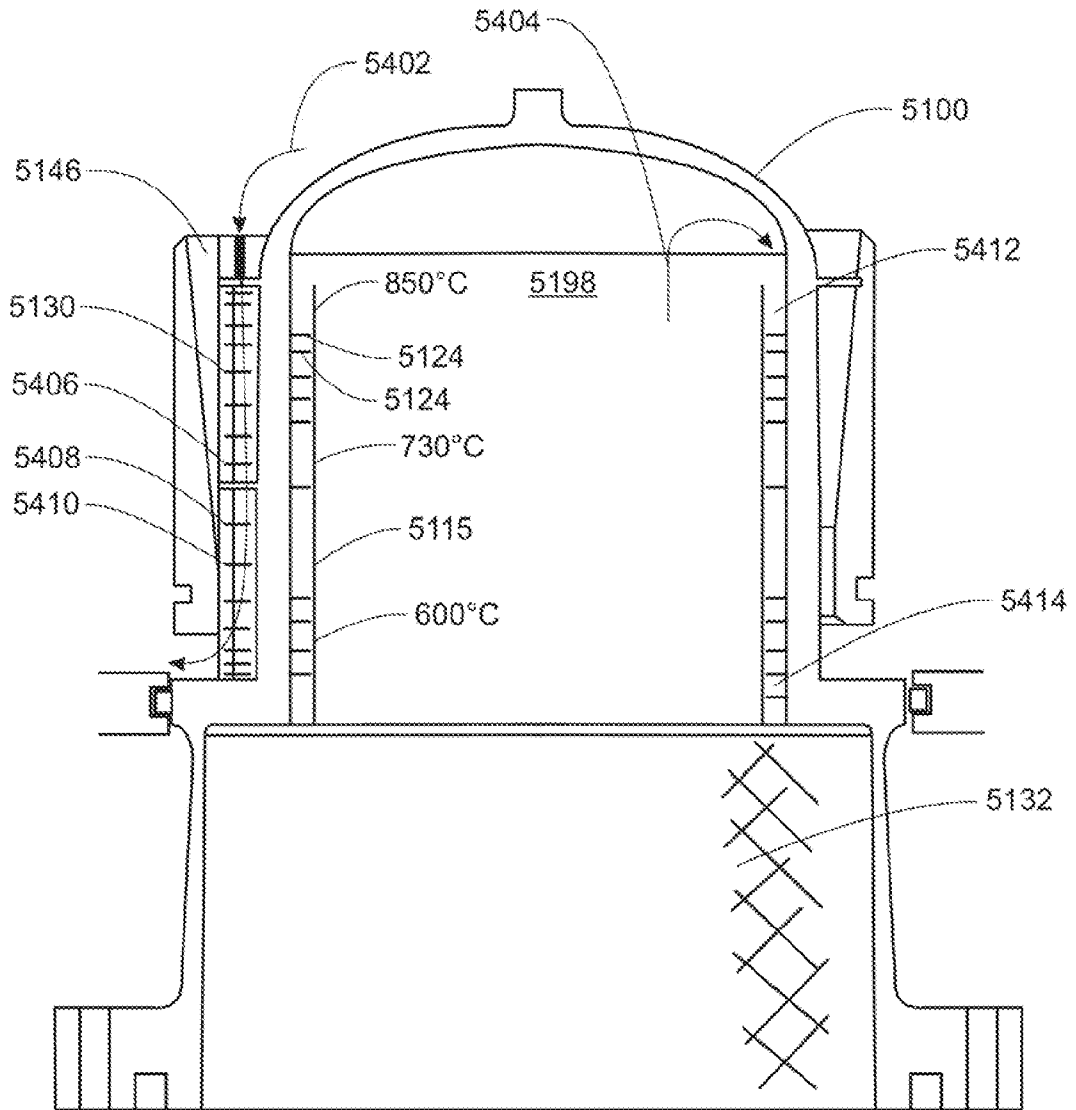

FIG. 54A

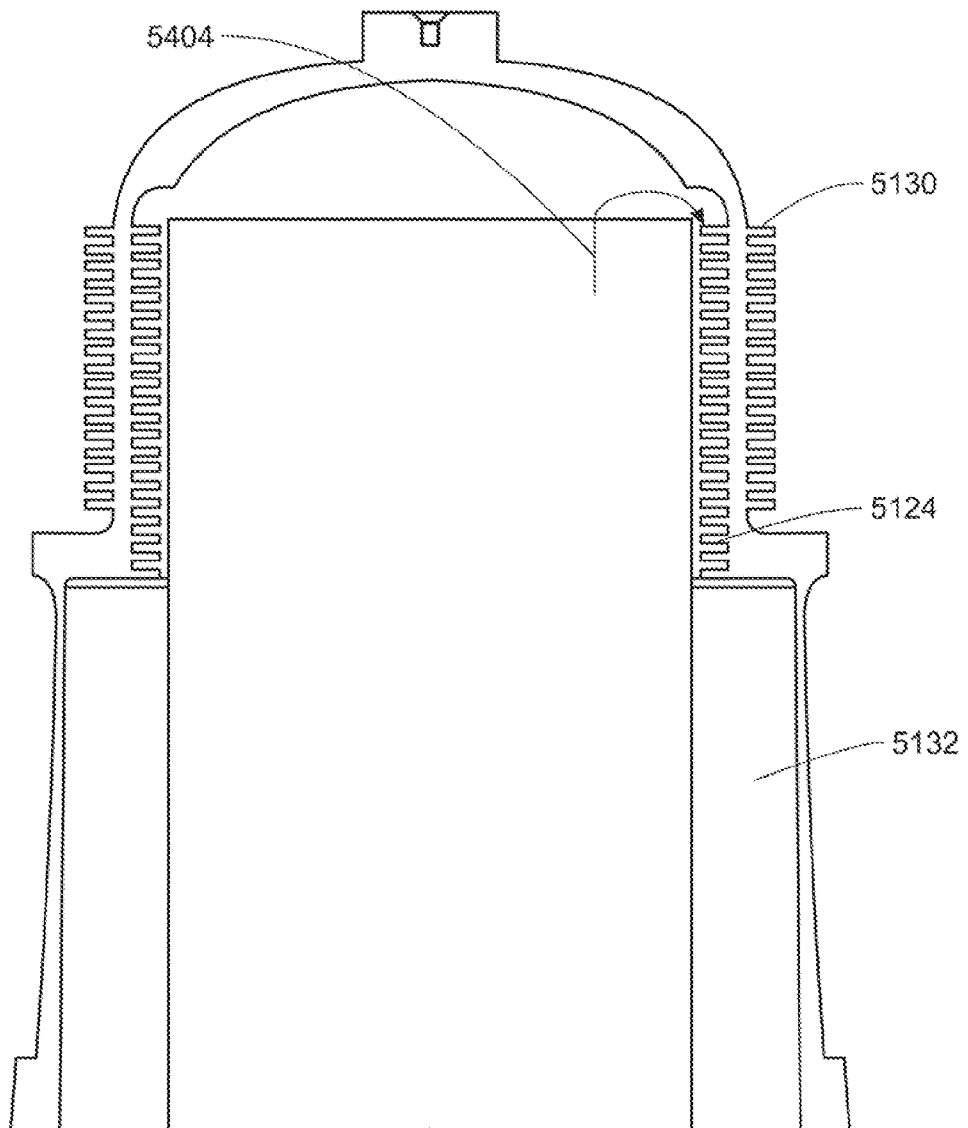

FIG. 54B

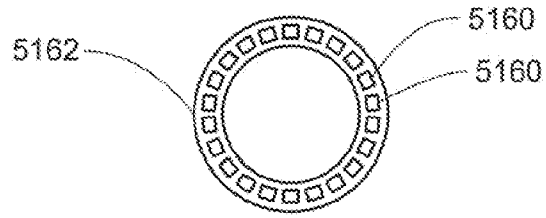

FIG. 55A



FIG. 55B

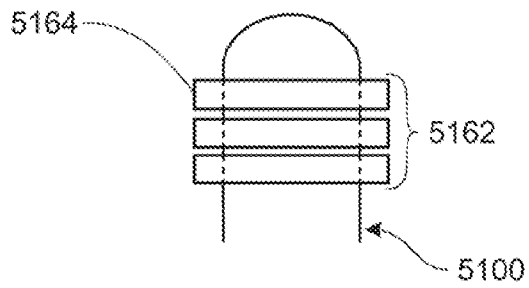

FIG. 55C

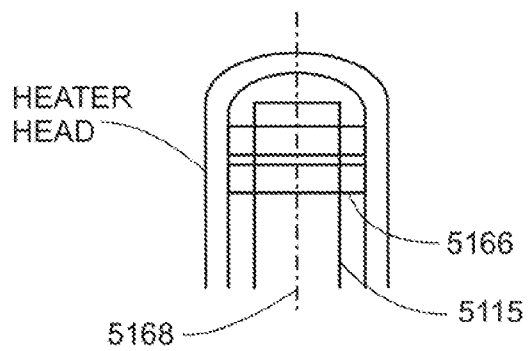
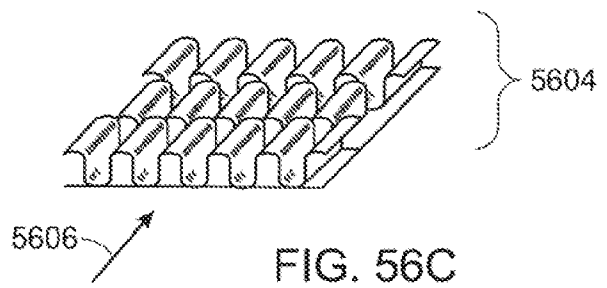
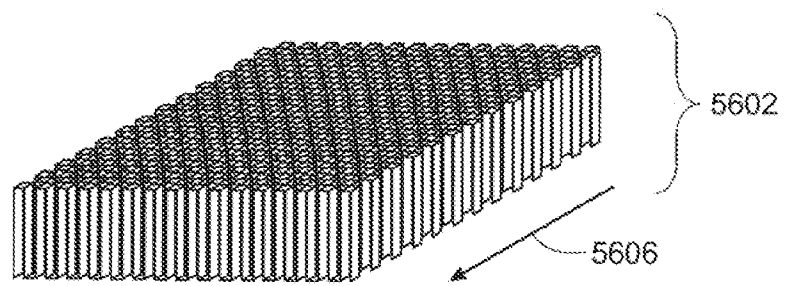
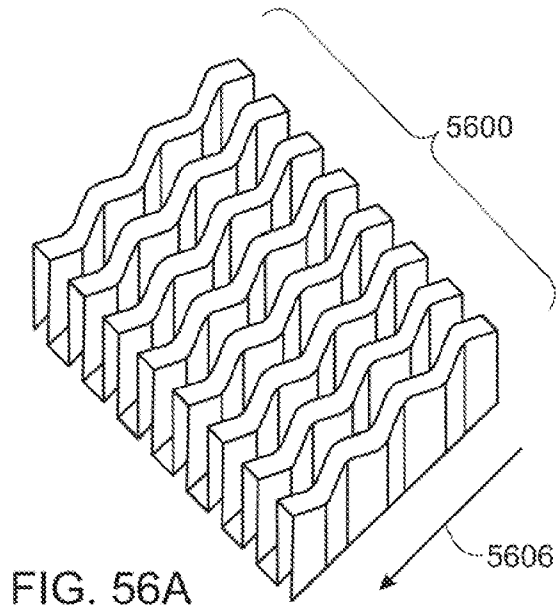

FIG. 55D



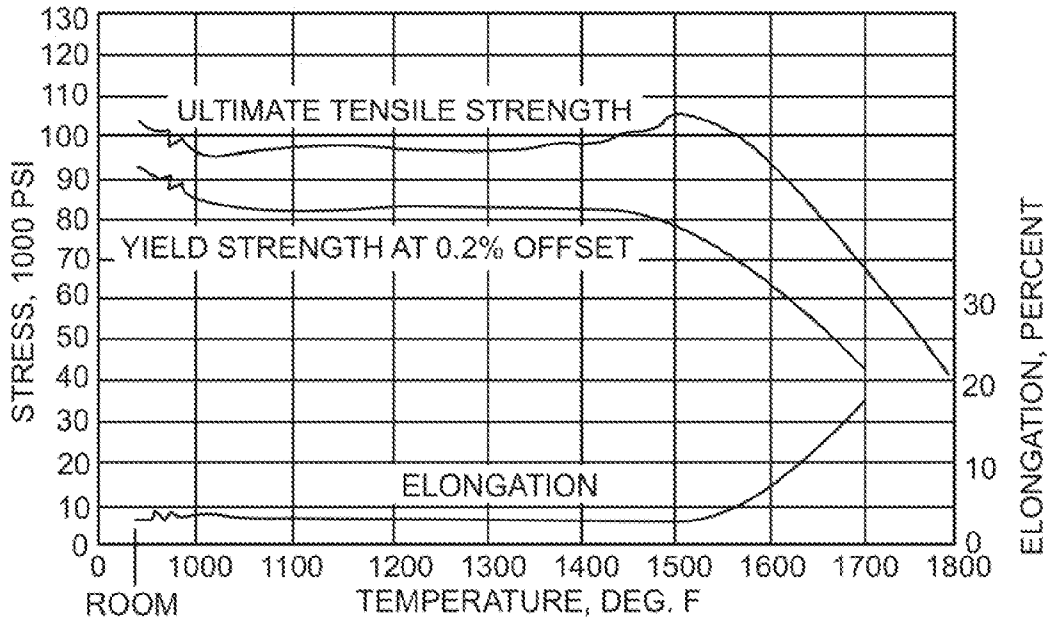

FIG. 57A

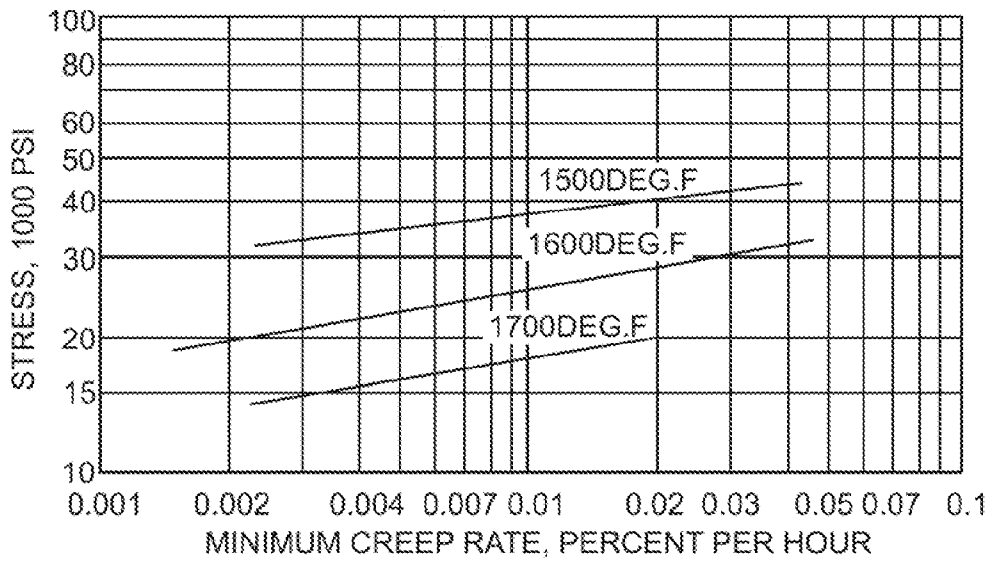

FIG. 57B

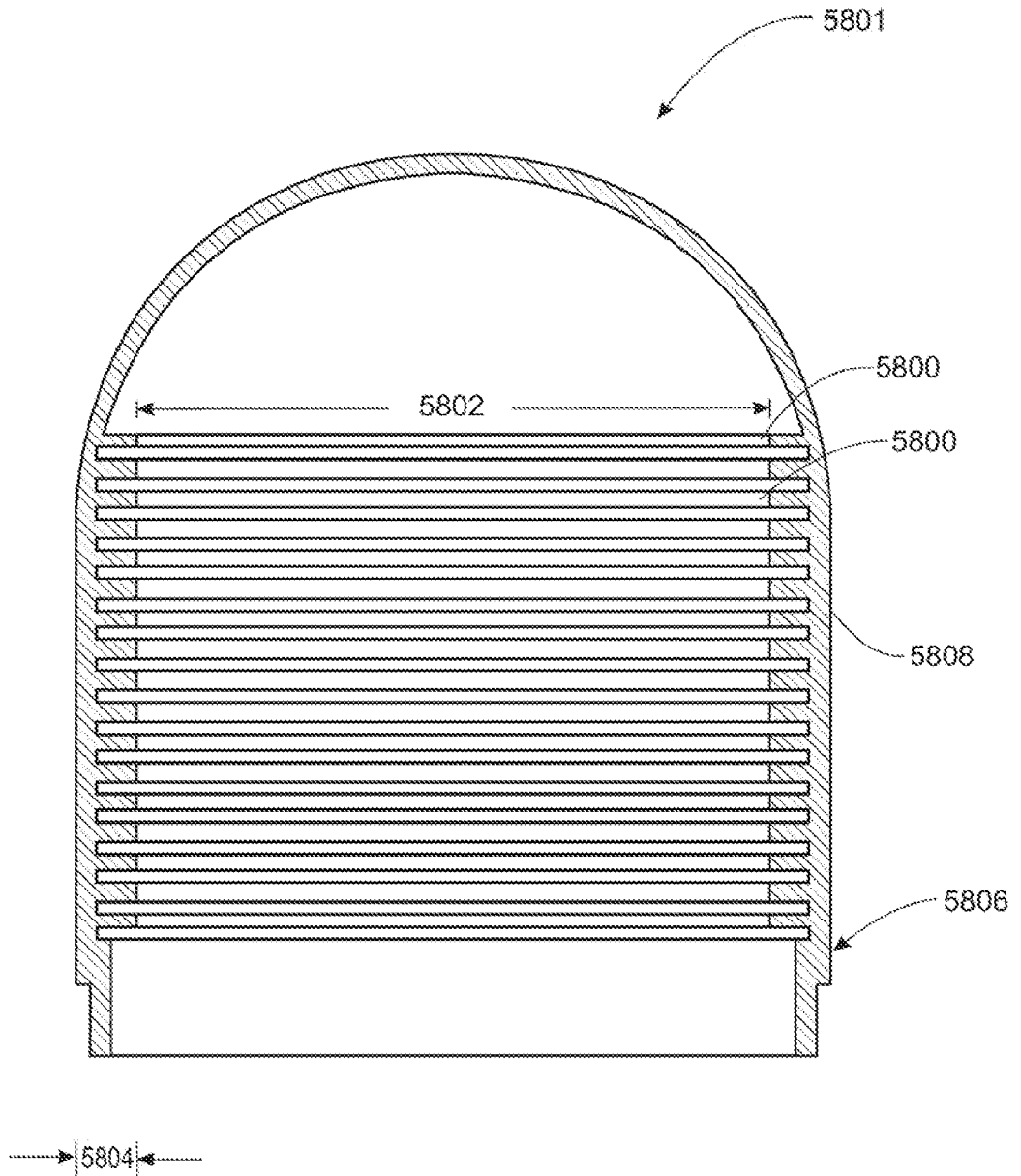

FIG. 58

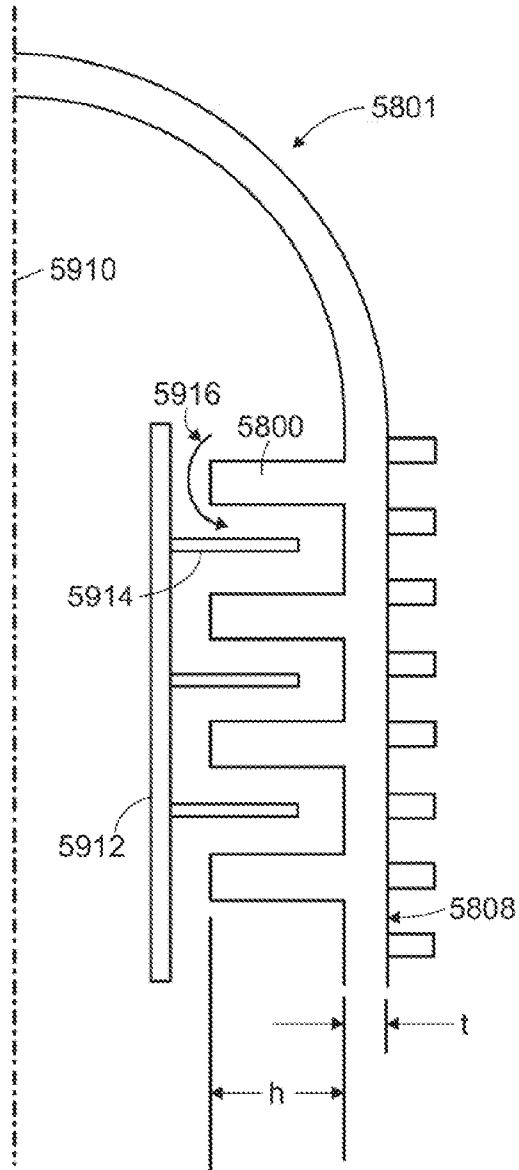

FIG. 59

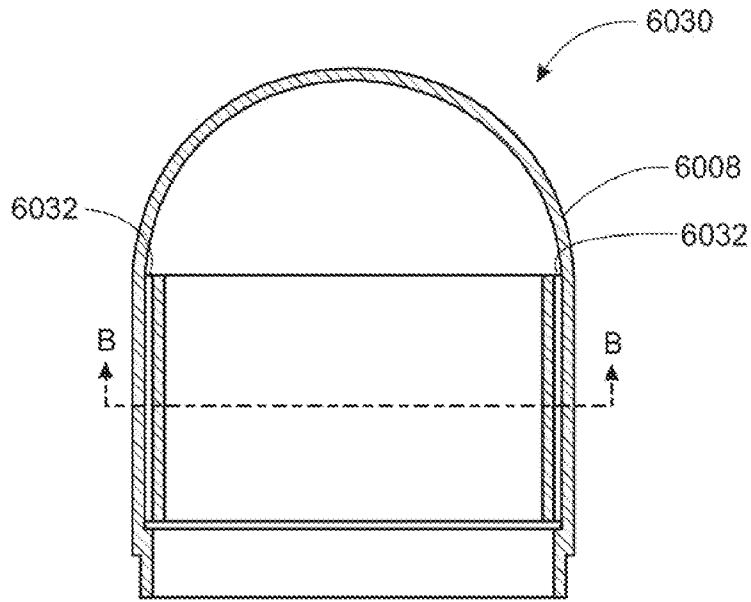

FIG. 60A

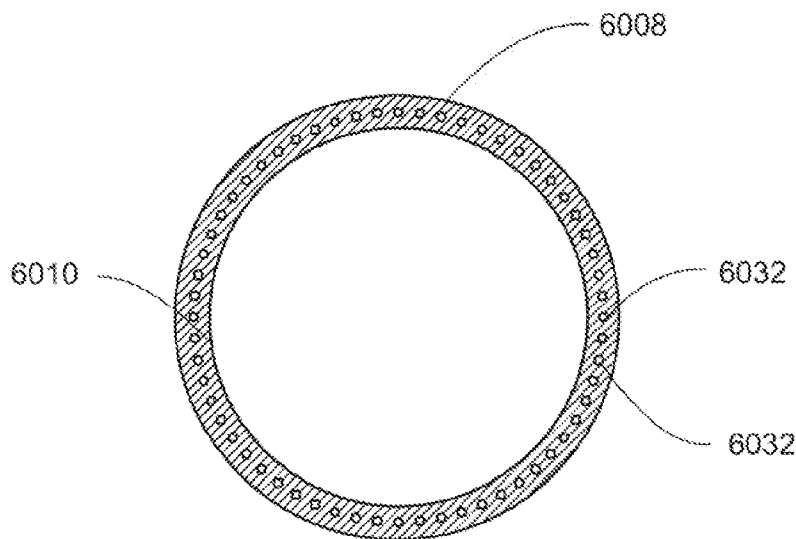

FIG. 60B

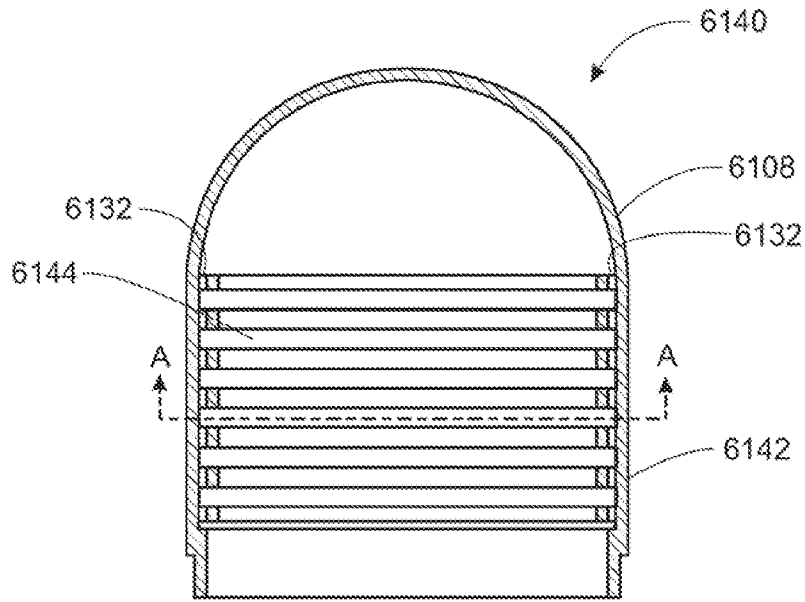

FIG. 61A

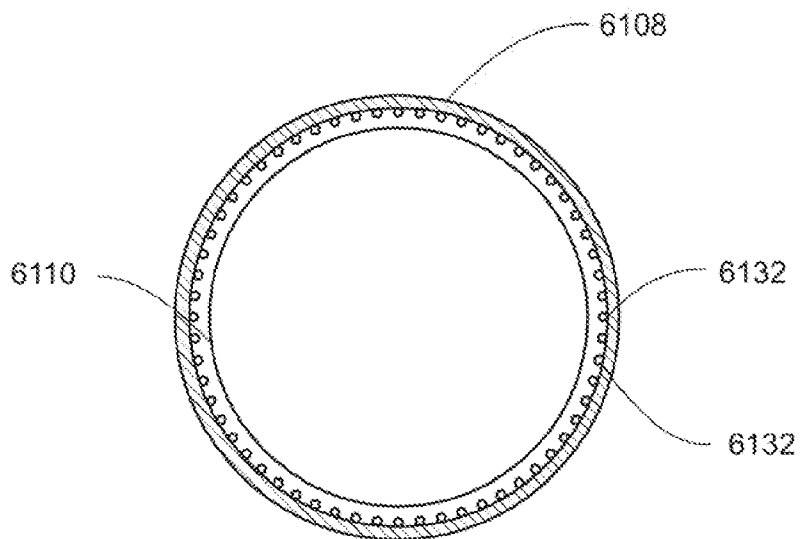

FIG. 61B

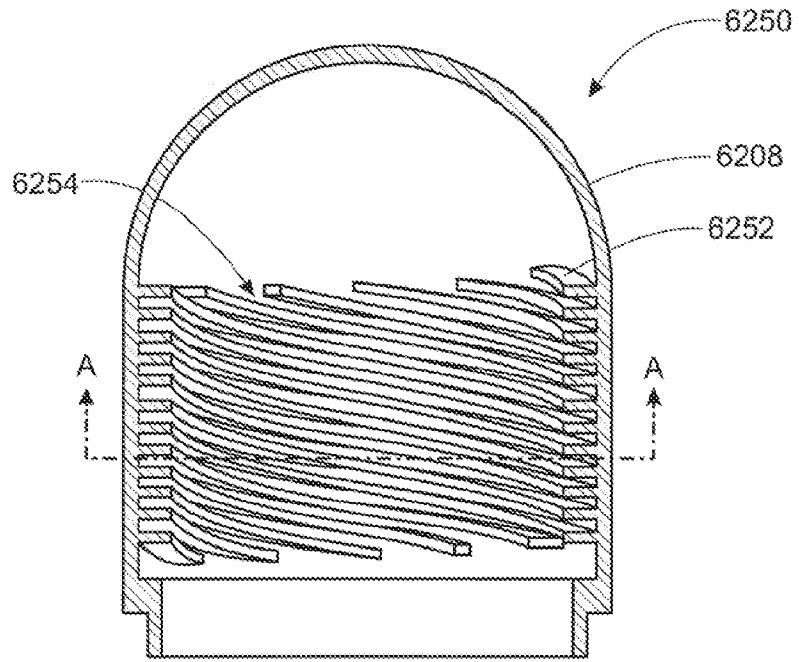

FIG. 62A

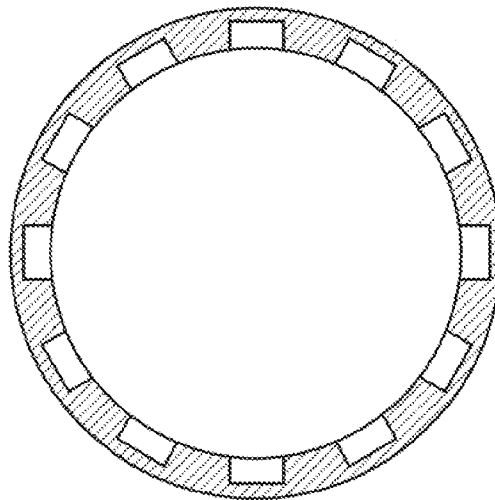

FIG. 62B

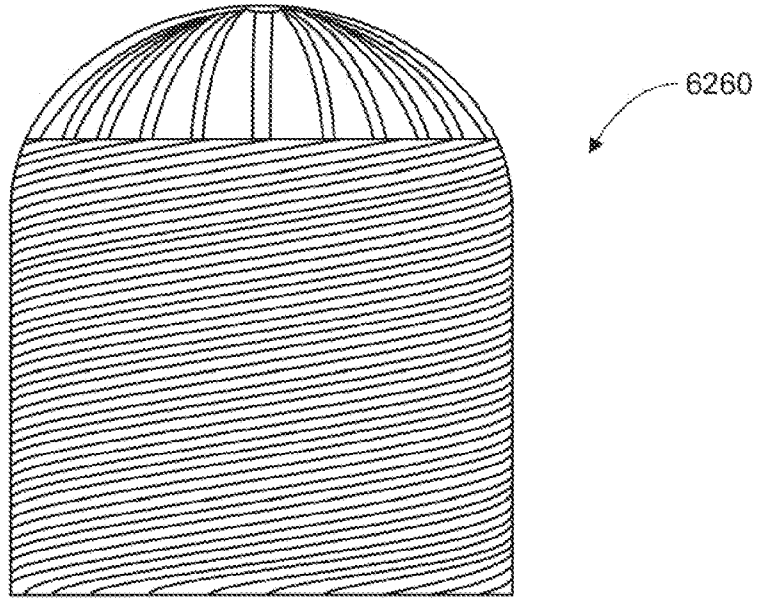

FIG. 62C

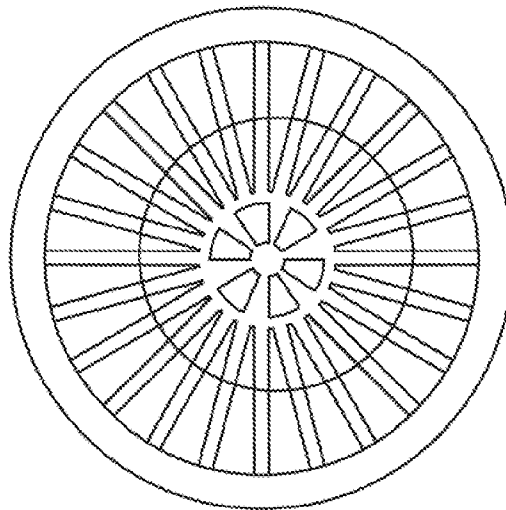

FIG. 62D

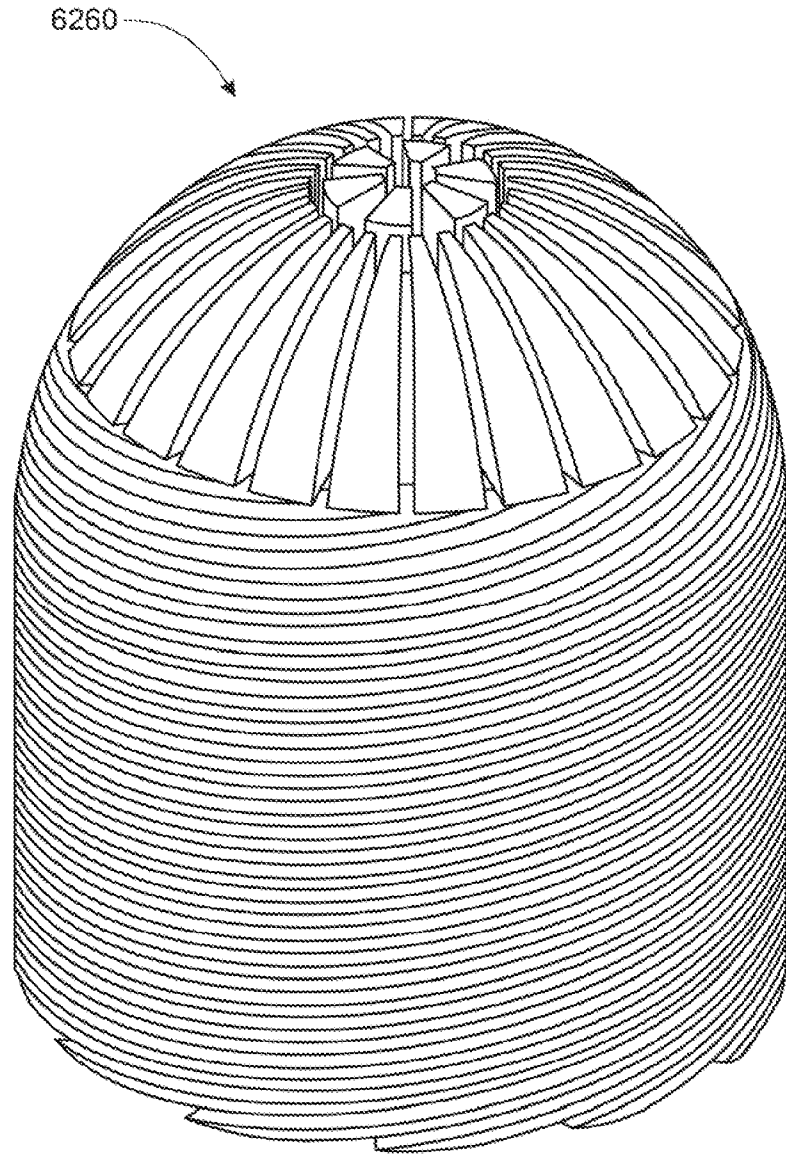

FIG. 62E

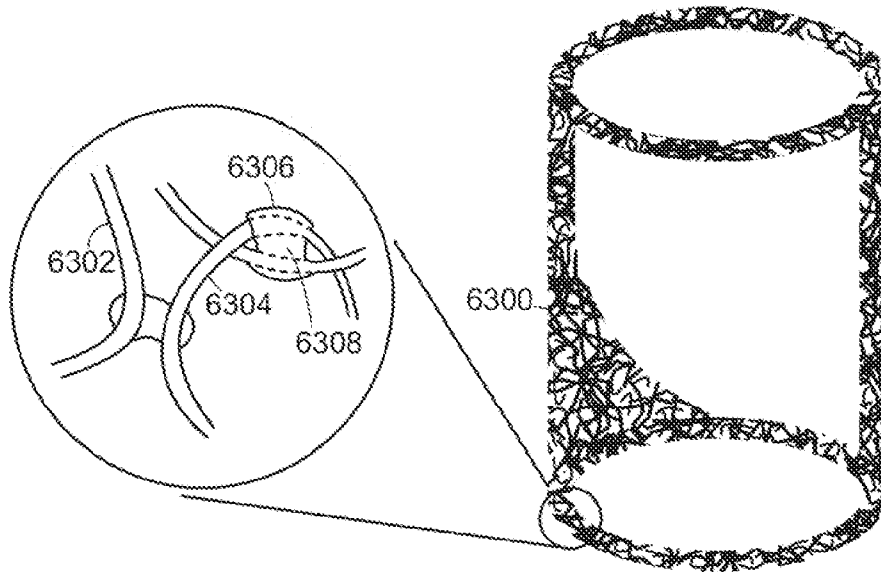

FIG. 63A

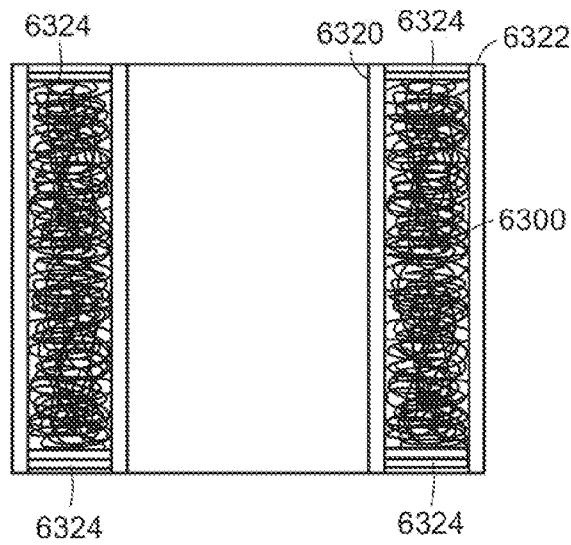

FIG. 63B

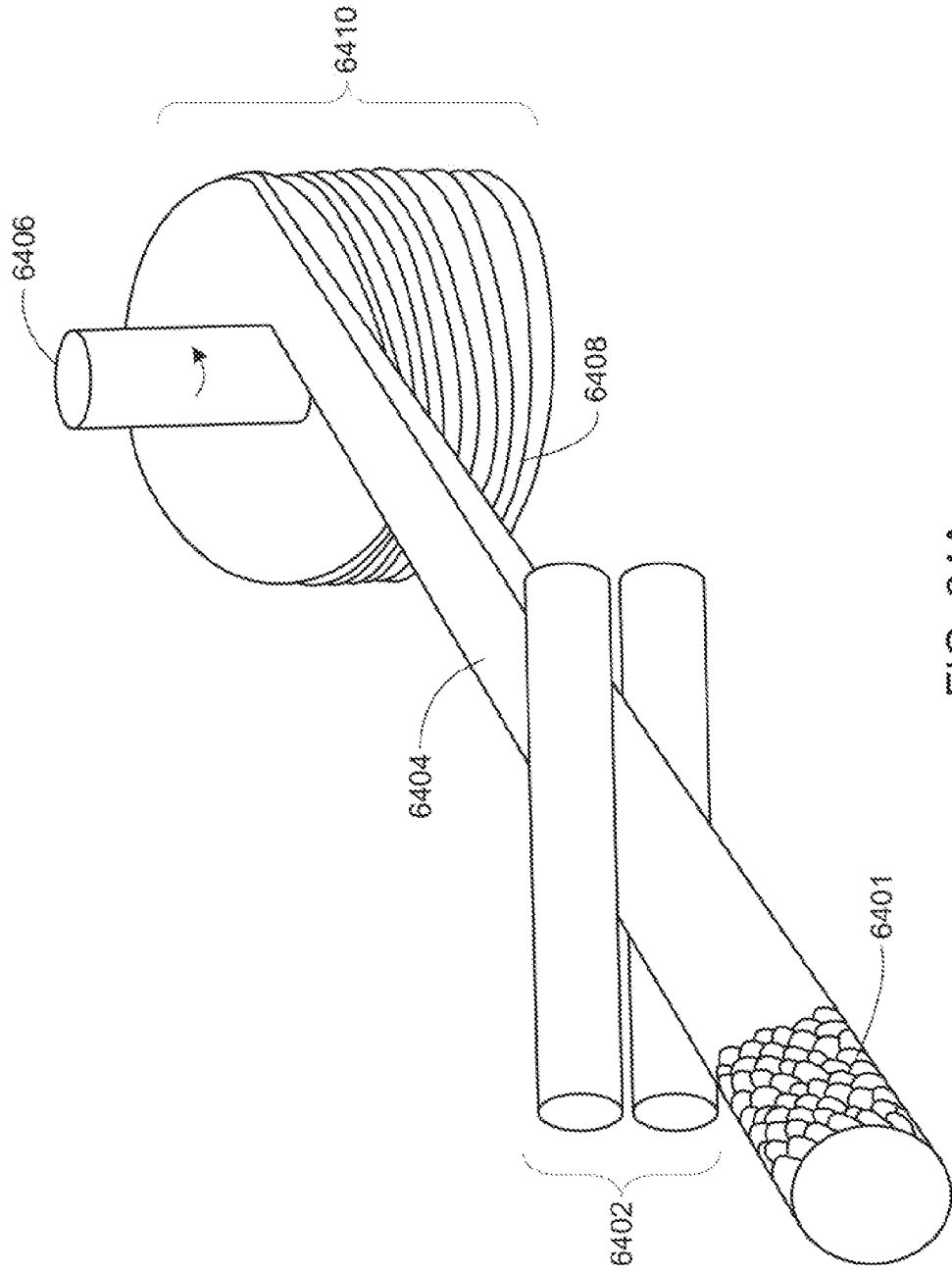

FIG. 64A

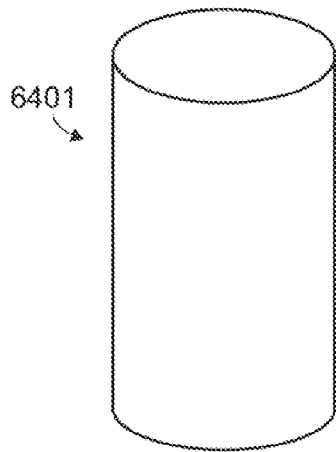

FIG. 64B

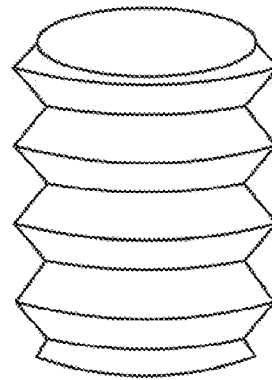

FIG. 64C

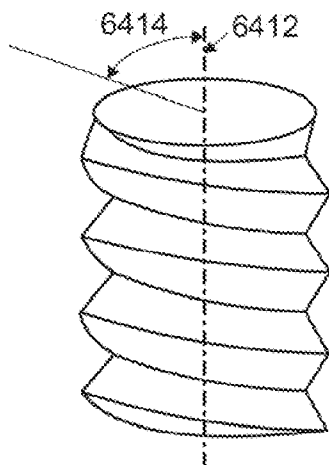

FIG. 64D

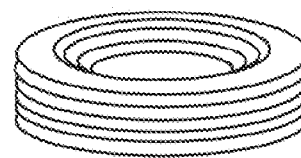

FIG. 64E

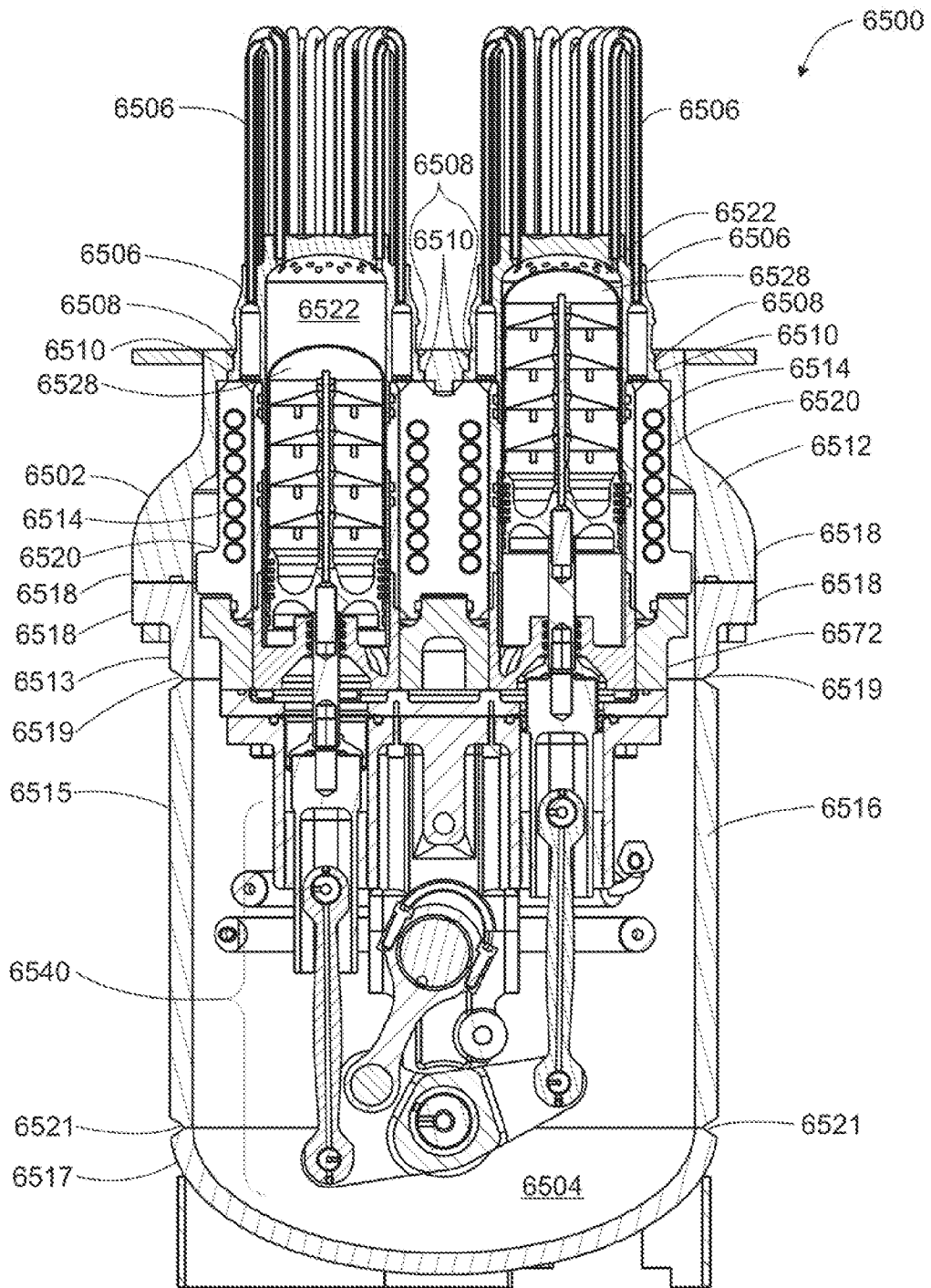

FIG. 65A

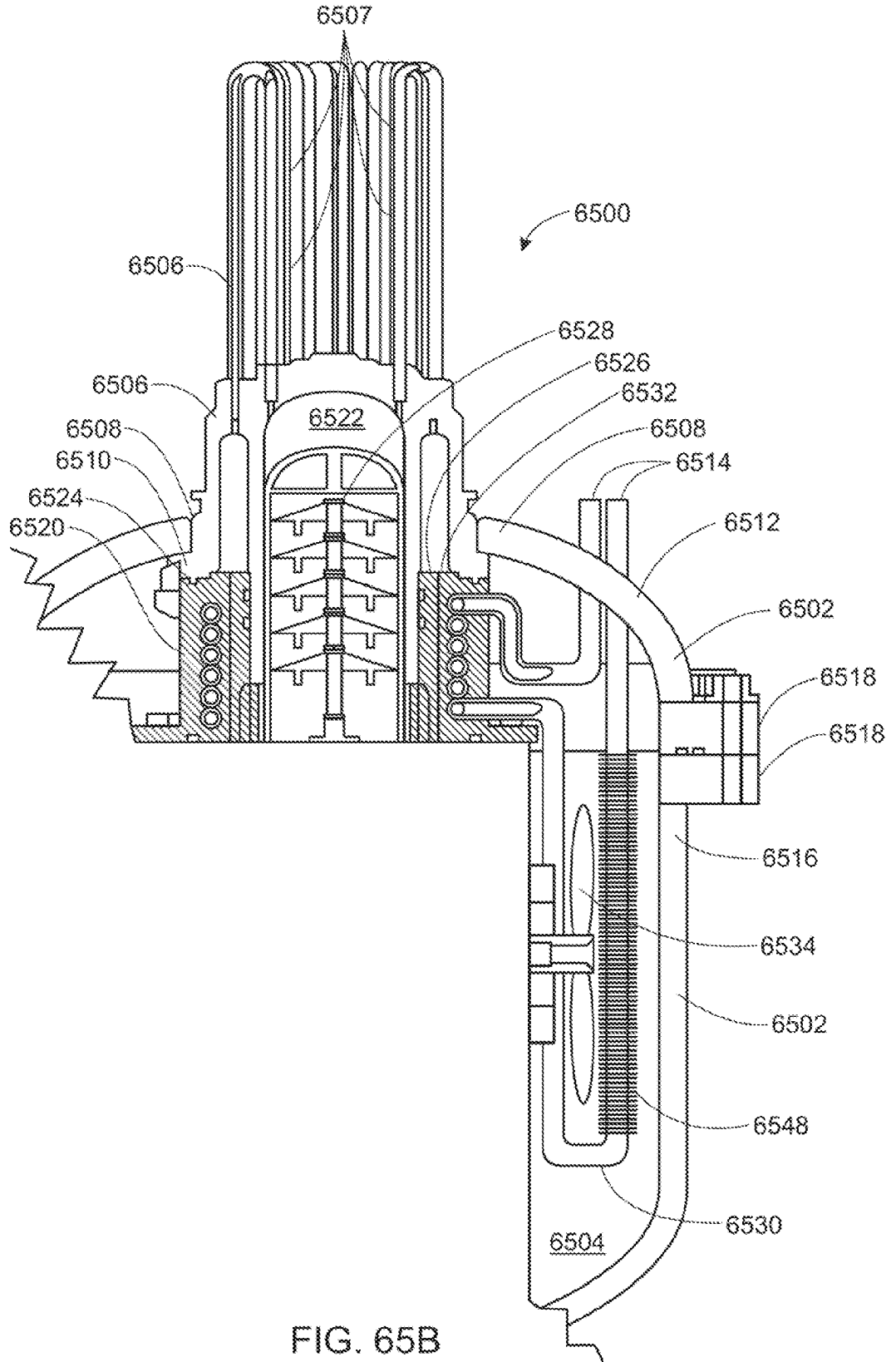

FIG. 65B

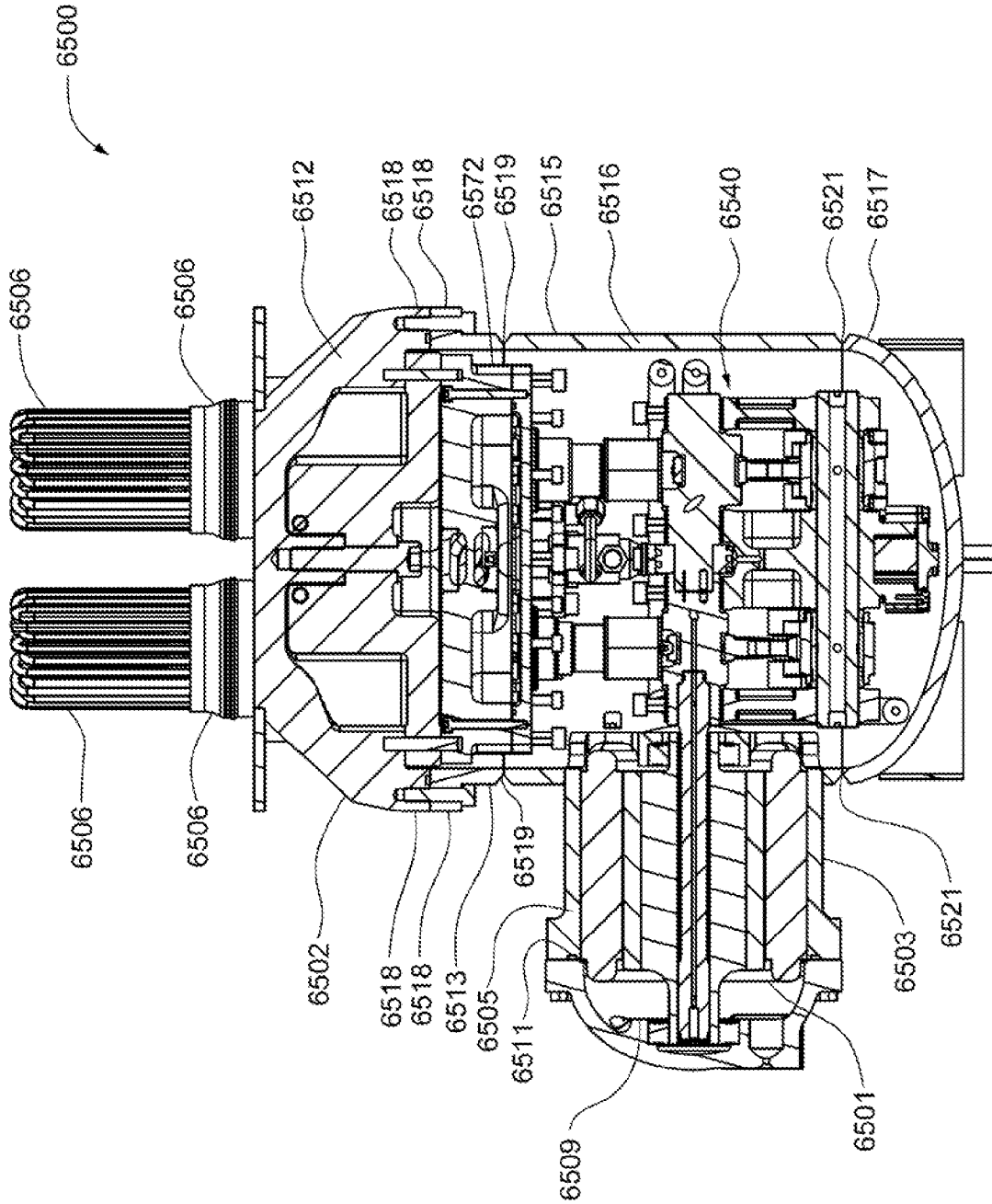

FIG. 65C

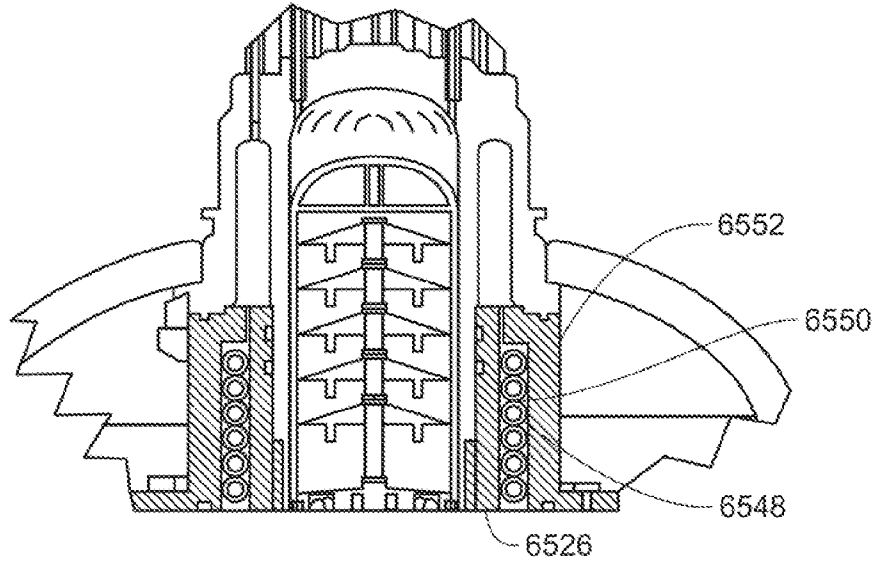

FIG. 65D

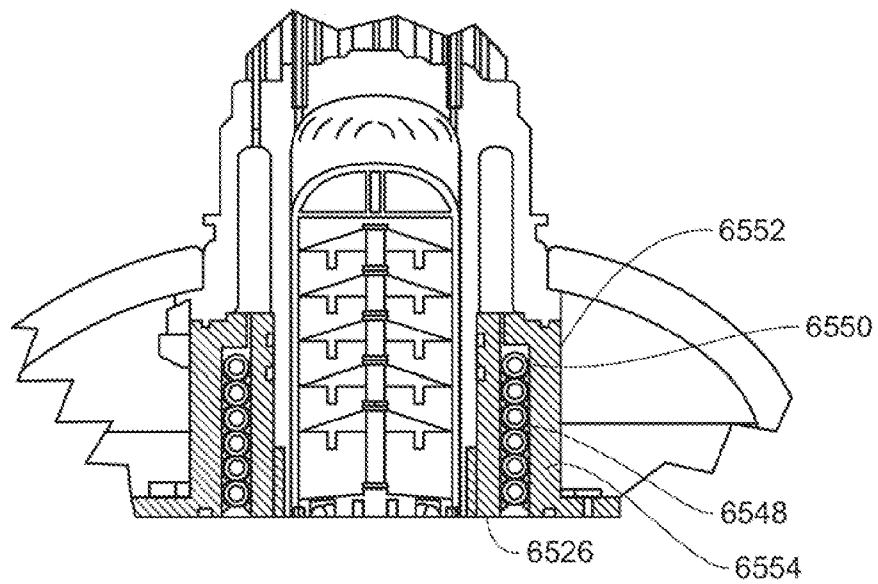

FIG. 65E

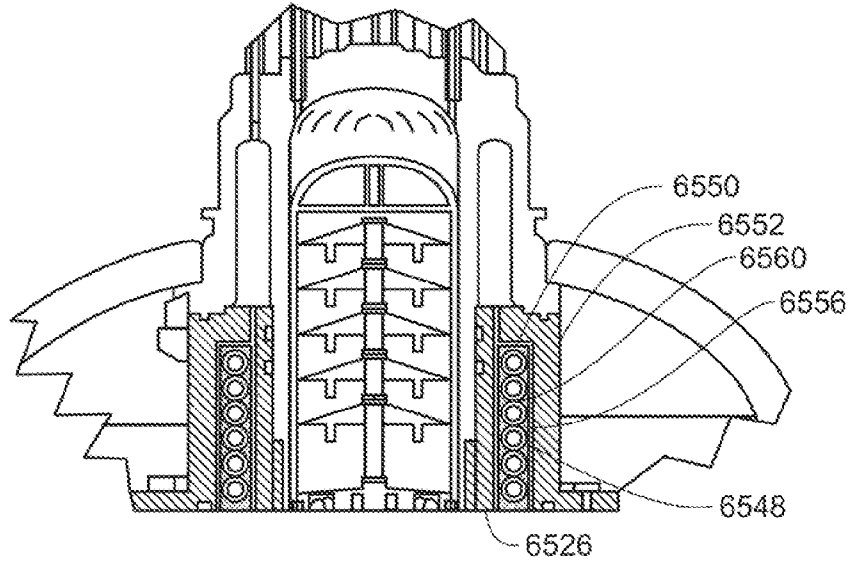

FIG. 65F

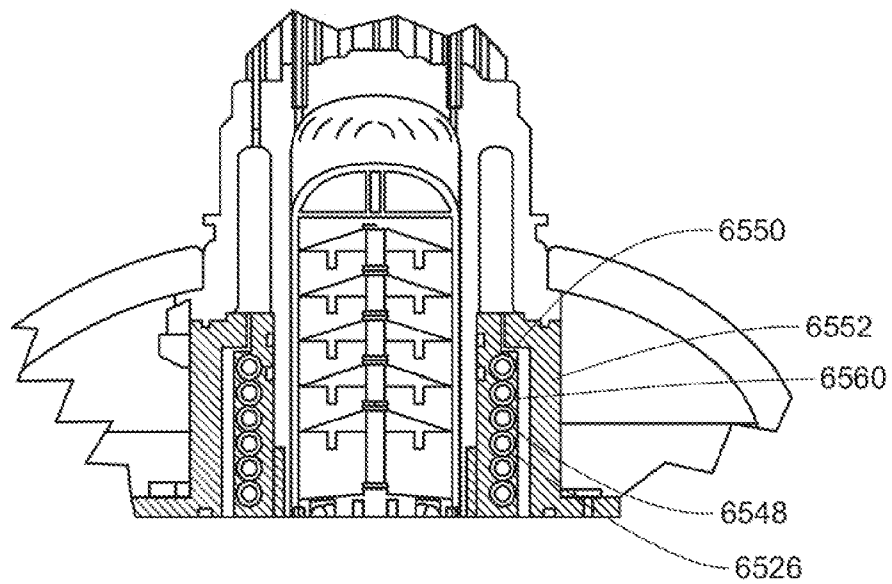

FIG. 65G

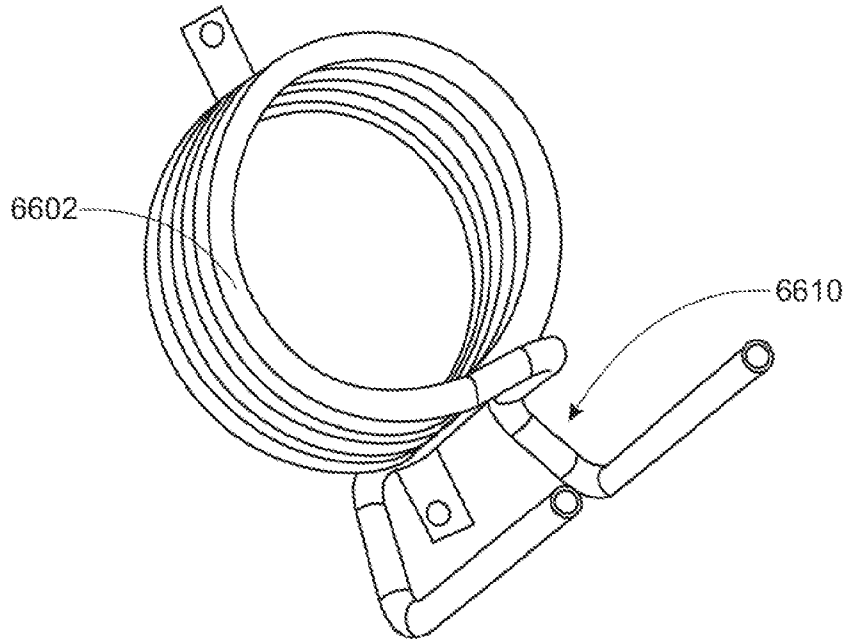

FIG. 66A

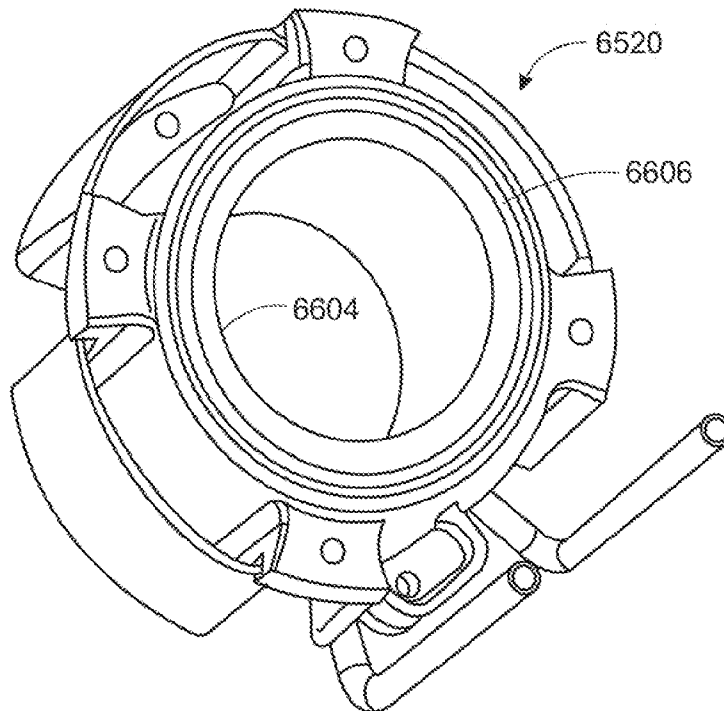

FIG. 66B

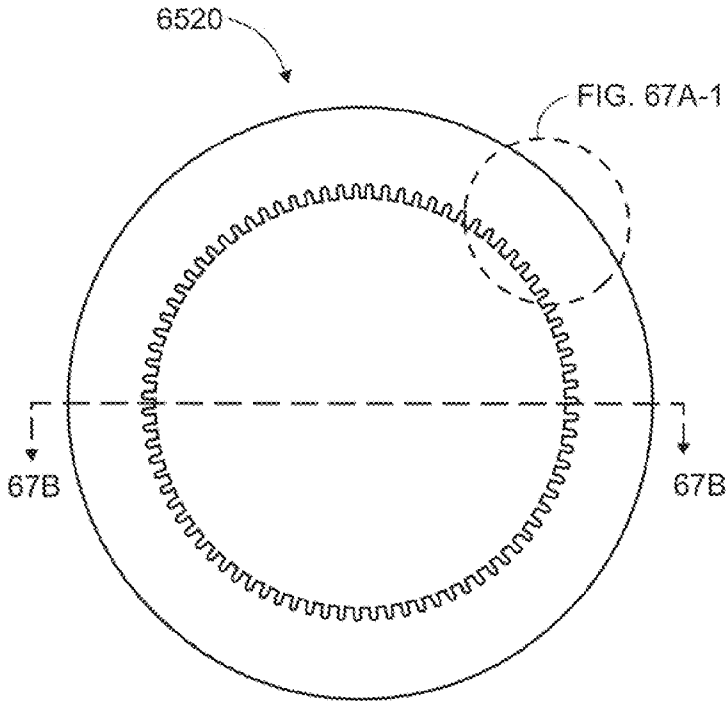

FIG. 67A

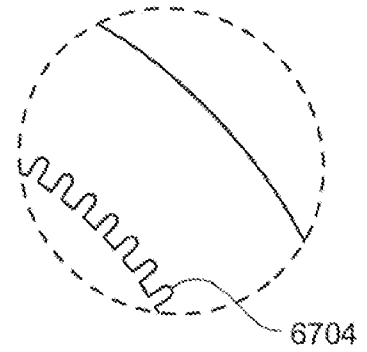

FIG. 67A-1

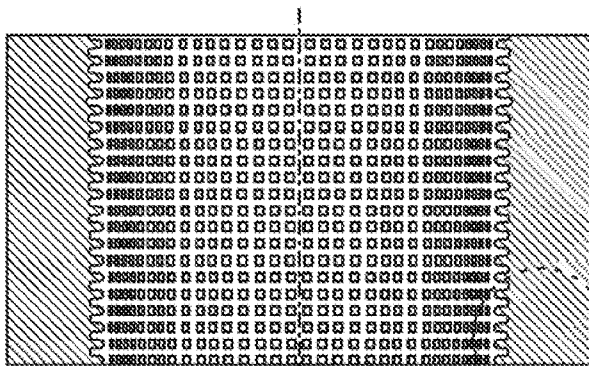

FIG. 67B

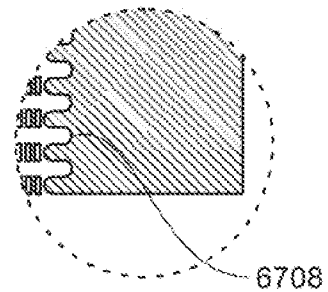

FIG. 67B-1

FIG. 67B-1

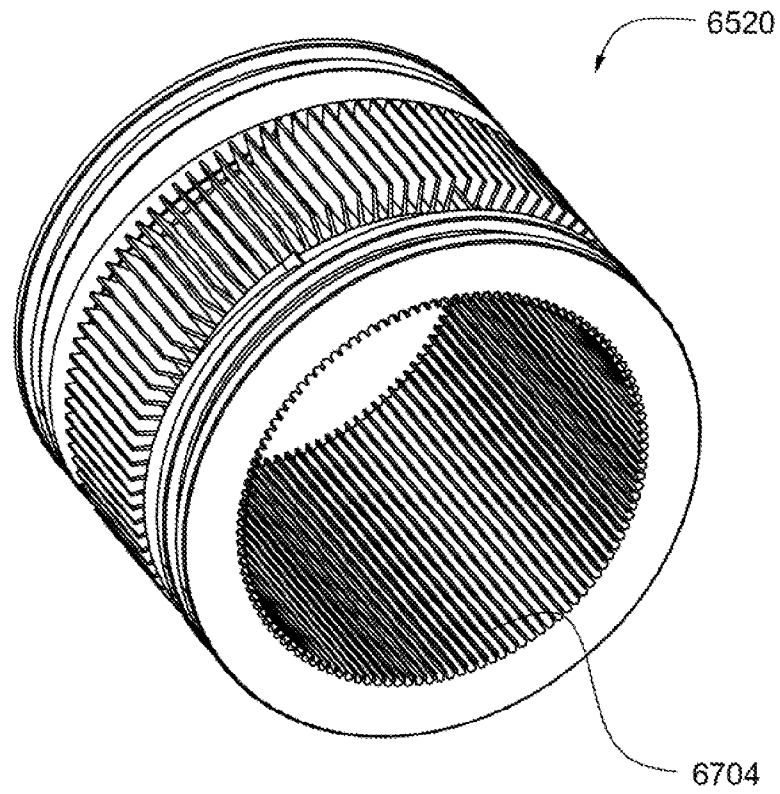

FIG. 67C

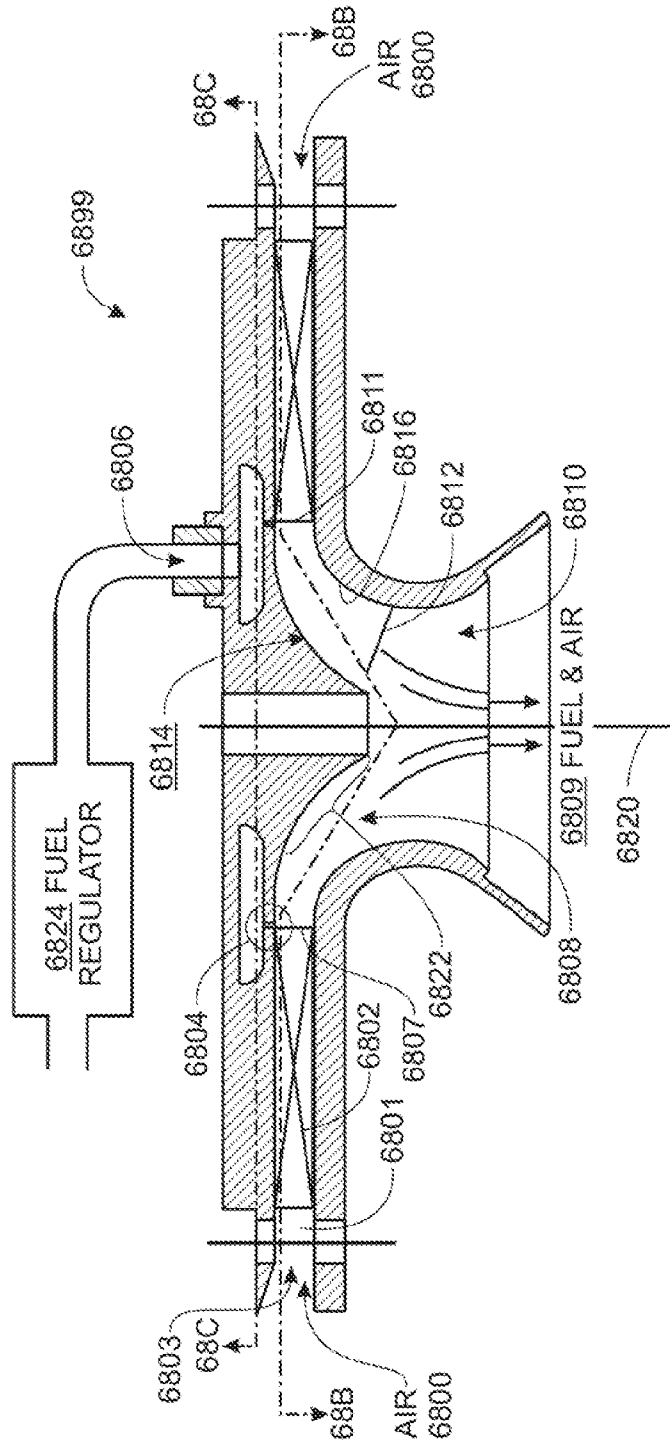

FIG. 68

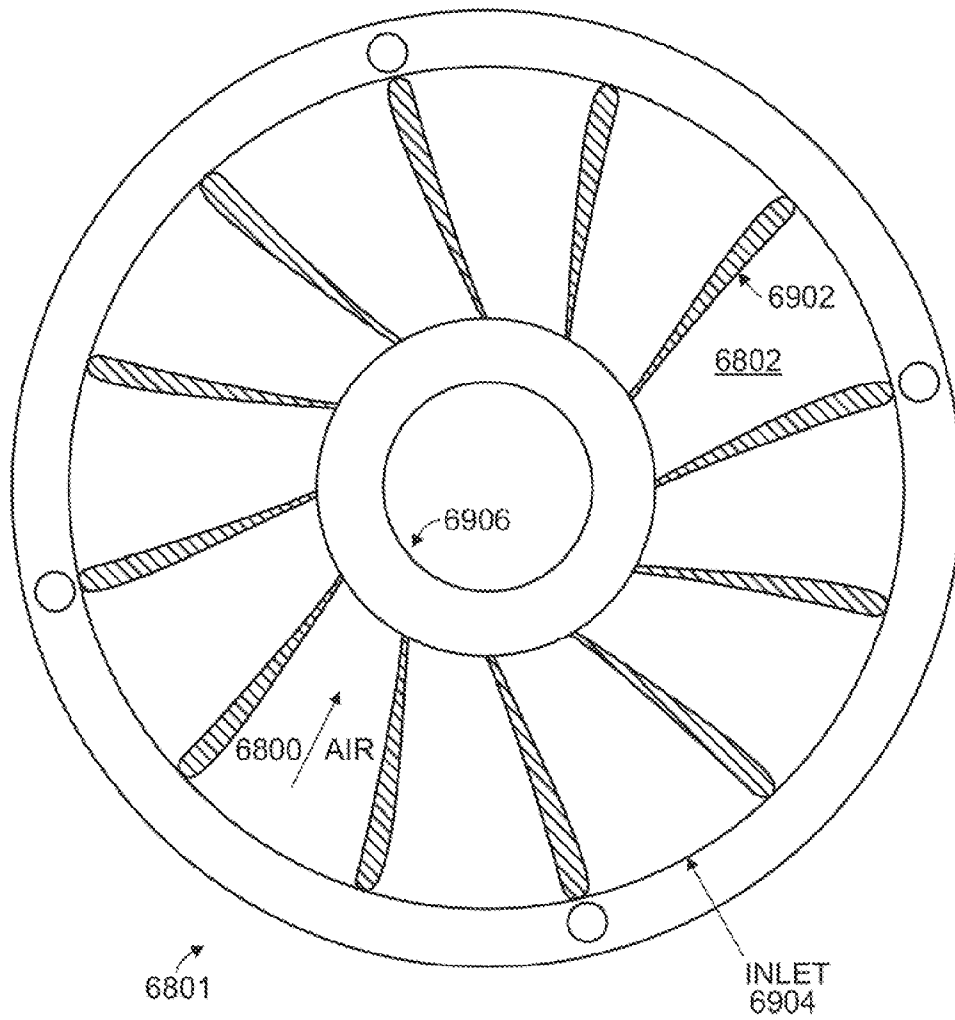

FIG. 69A

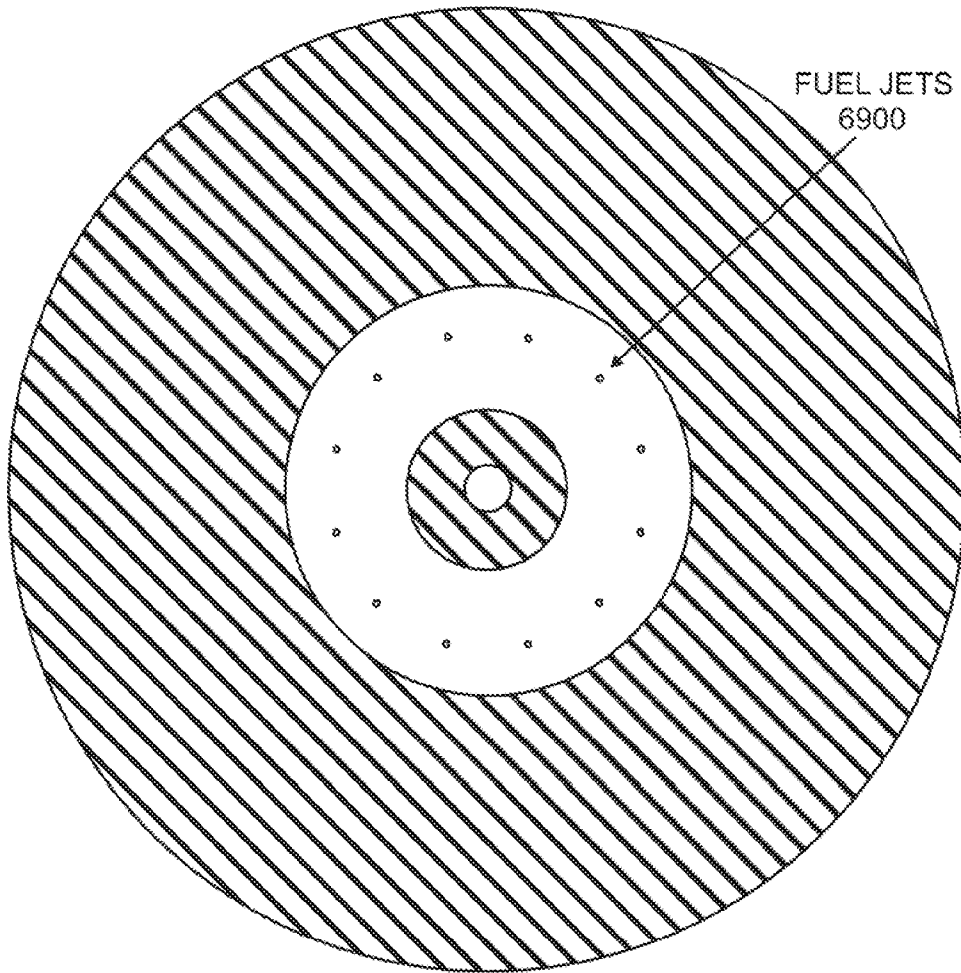

FIG. 69B

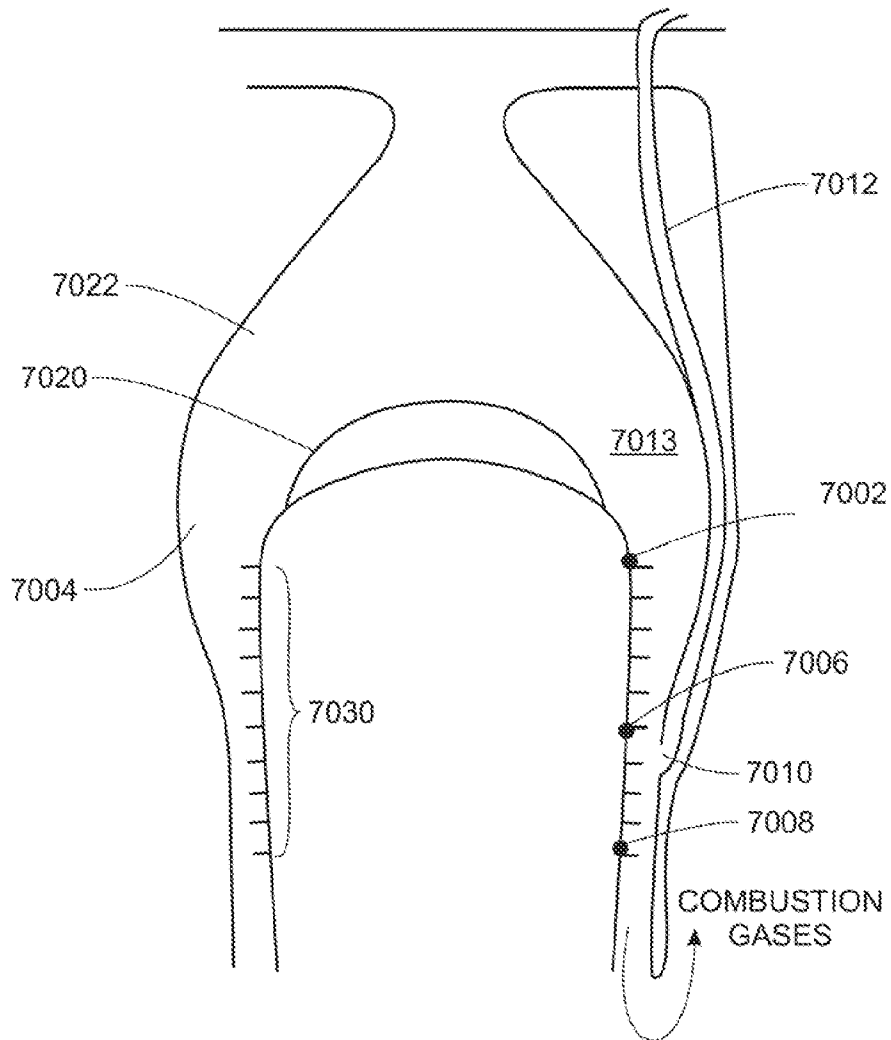

FIG. 70

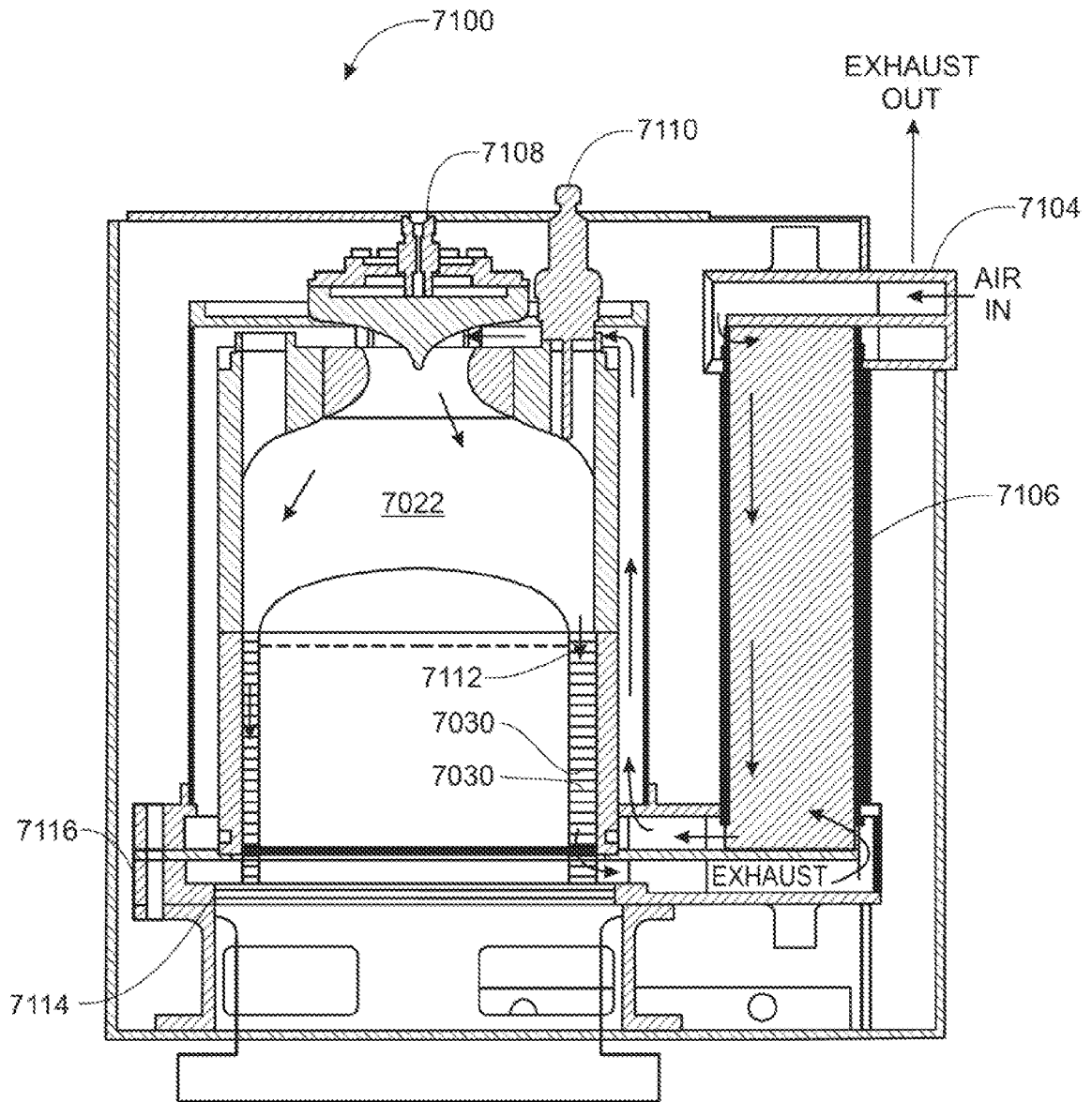

FIG. 71A

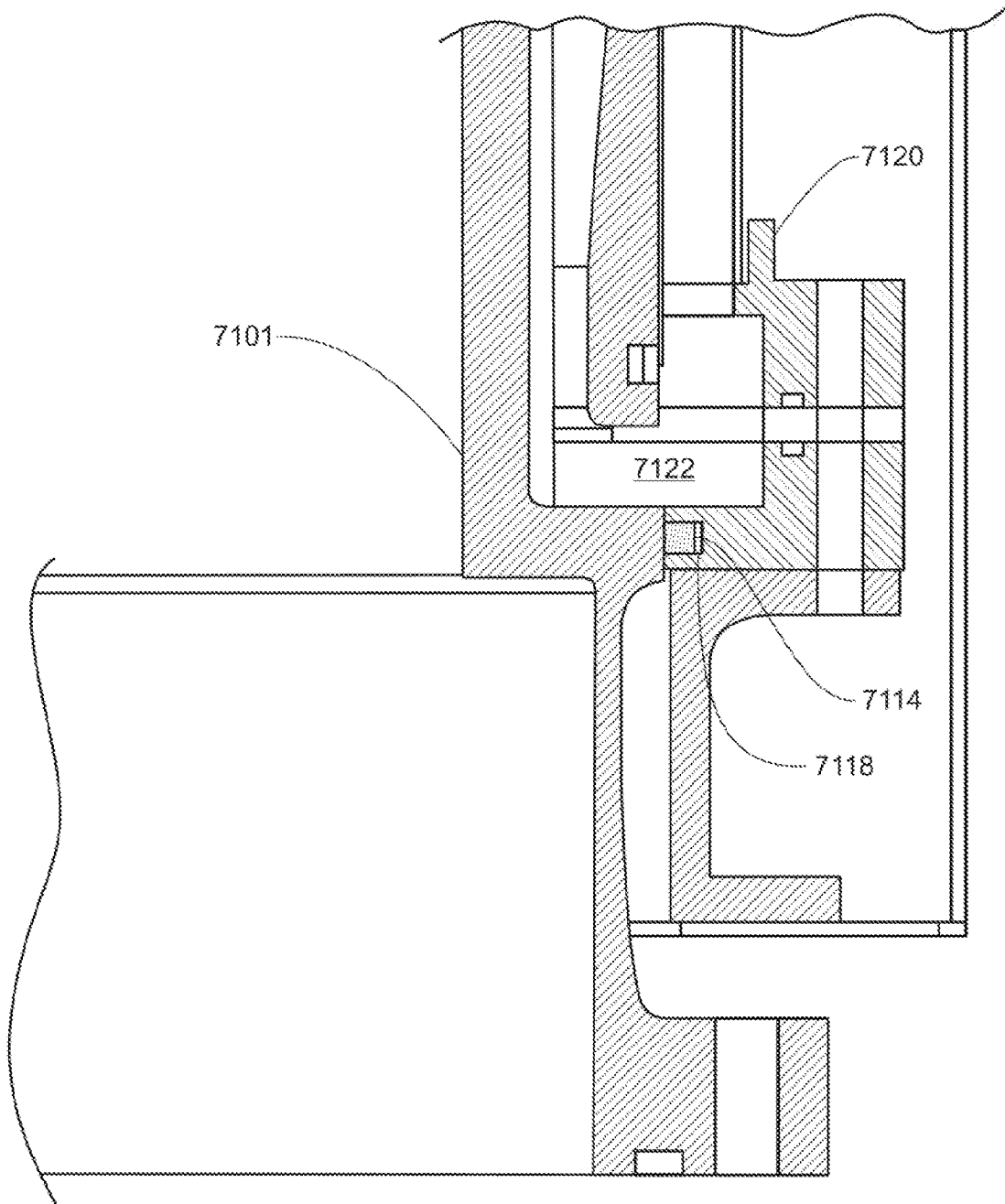

FIG. 71B

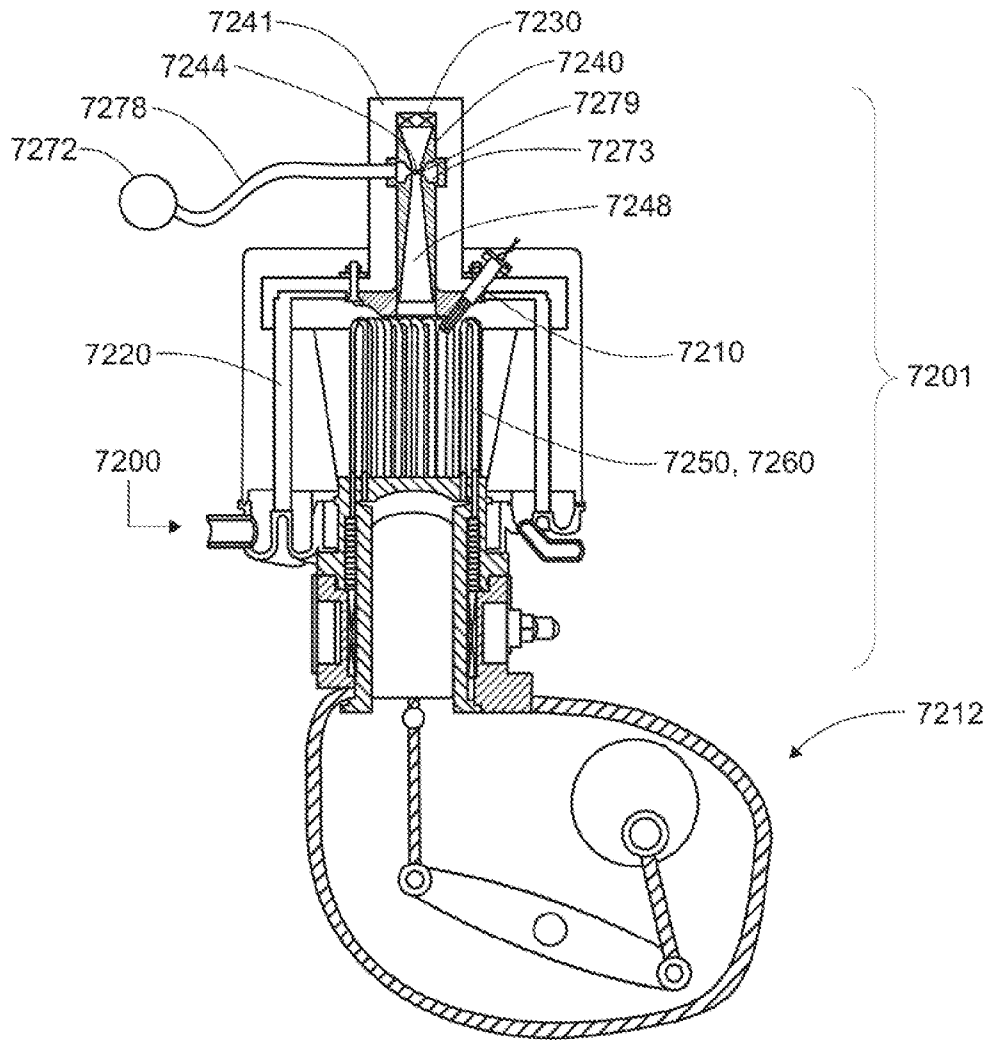

FIG. 72

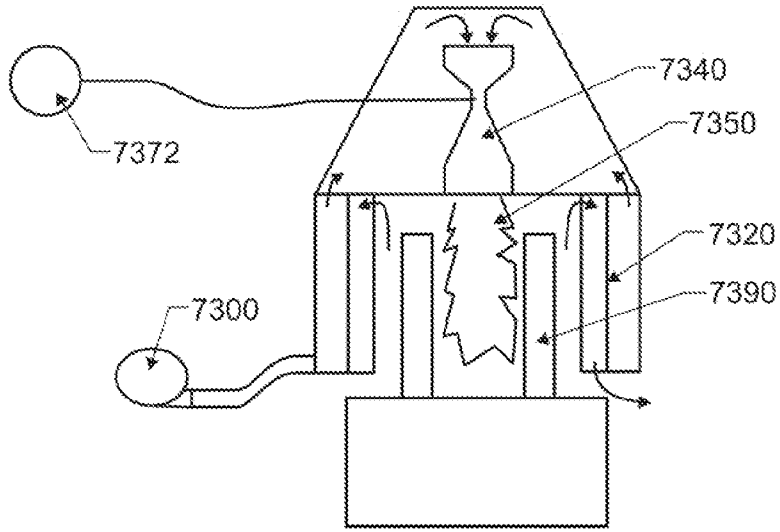

FIG. 73A

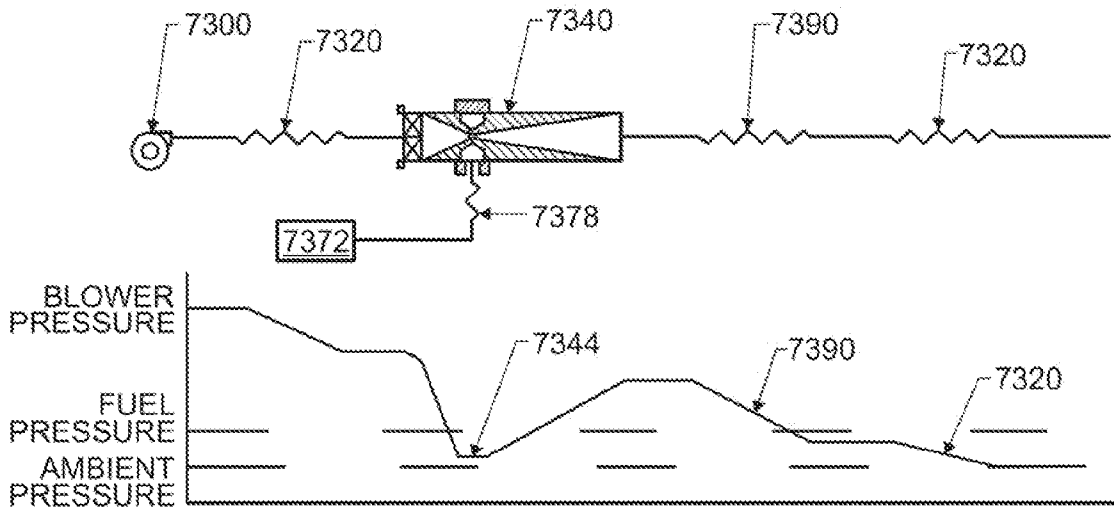

FIG. 73B

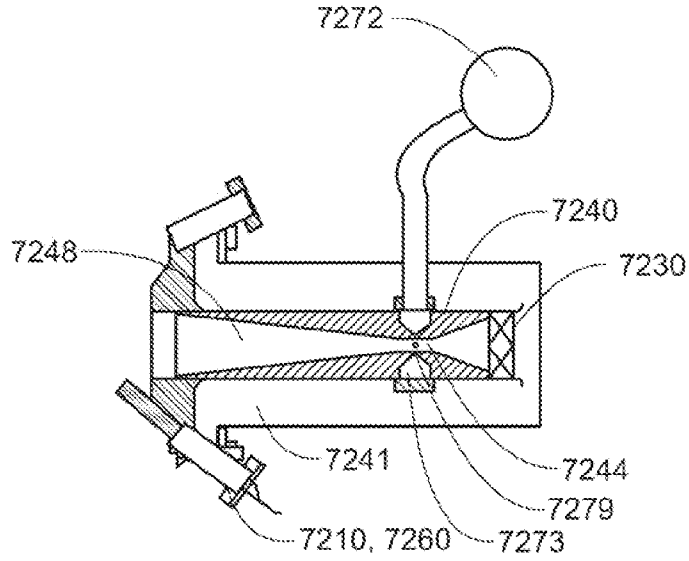

FIG. 74

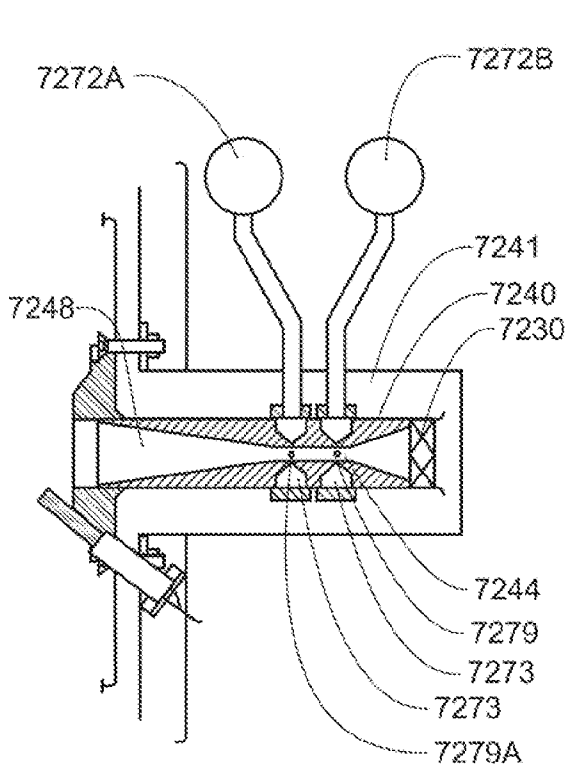

FIG. 75

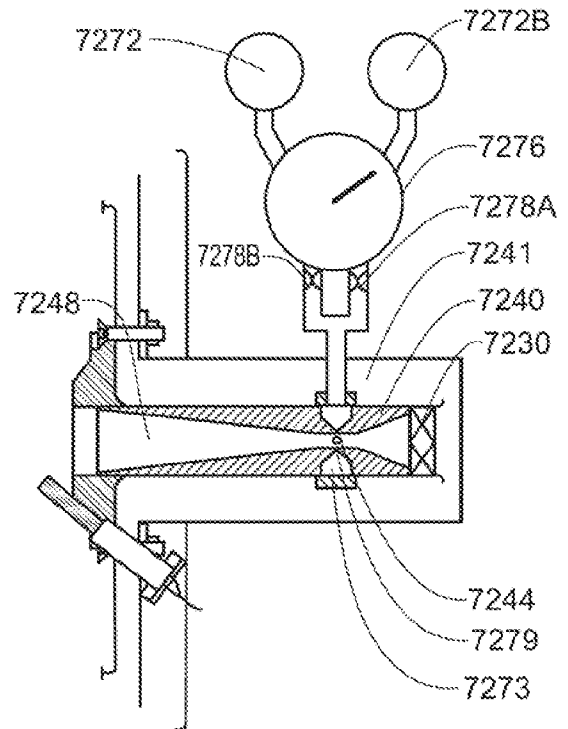

FIG. 75A

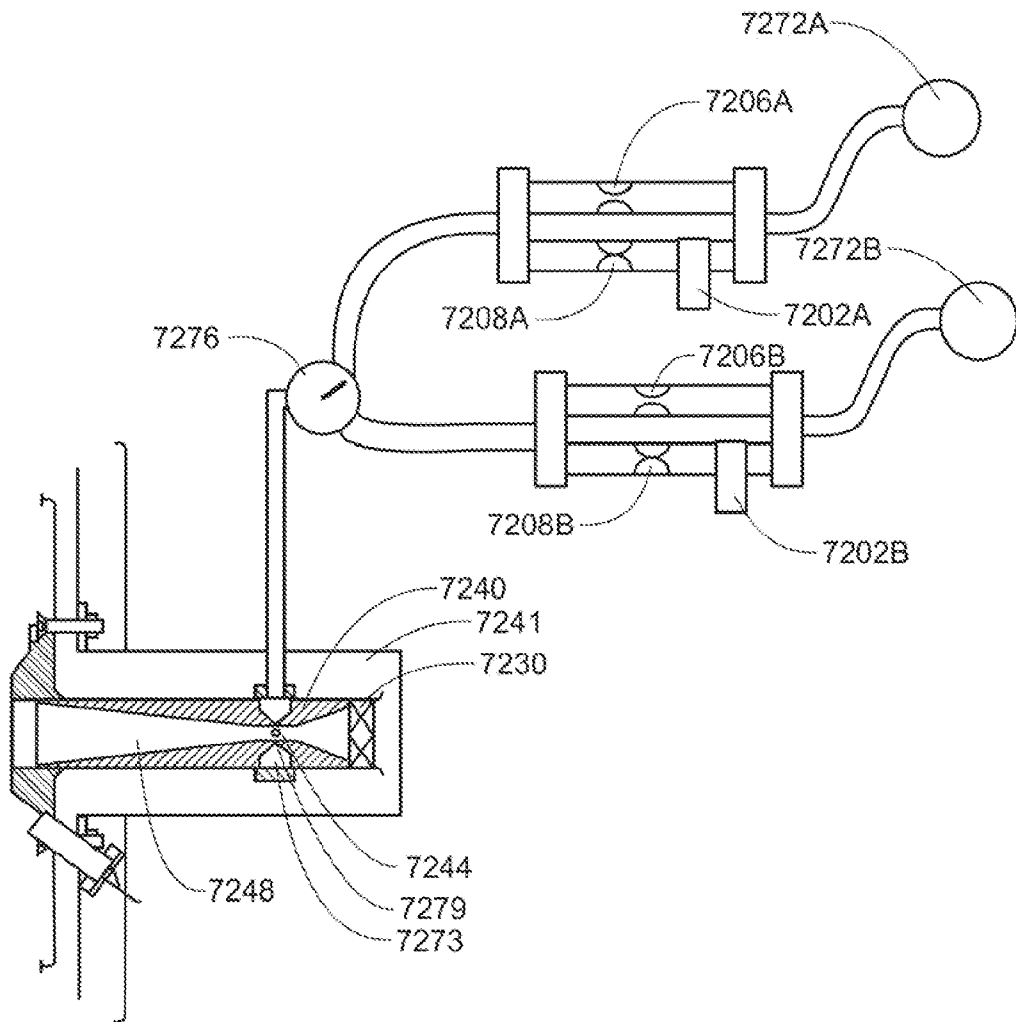

FIG. 75B

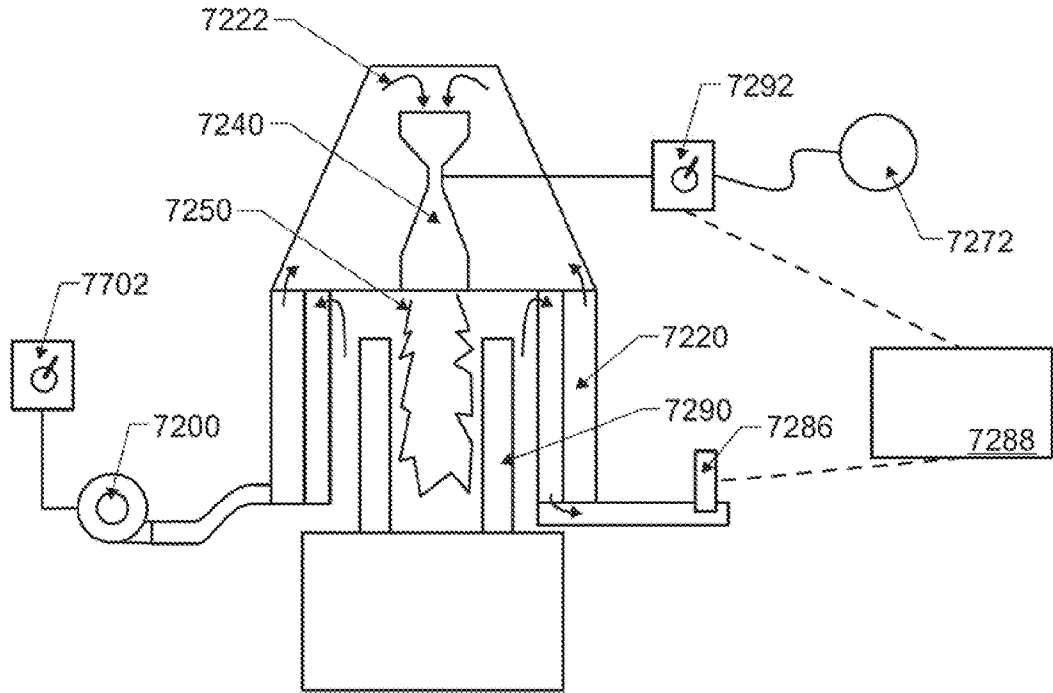

FIG. 76

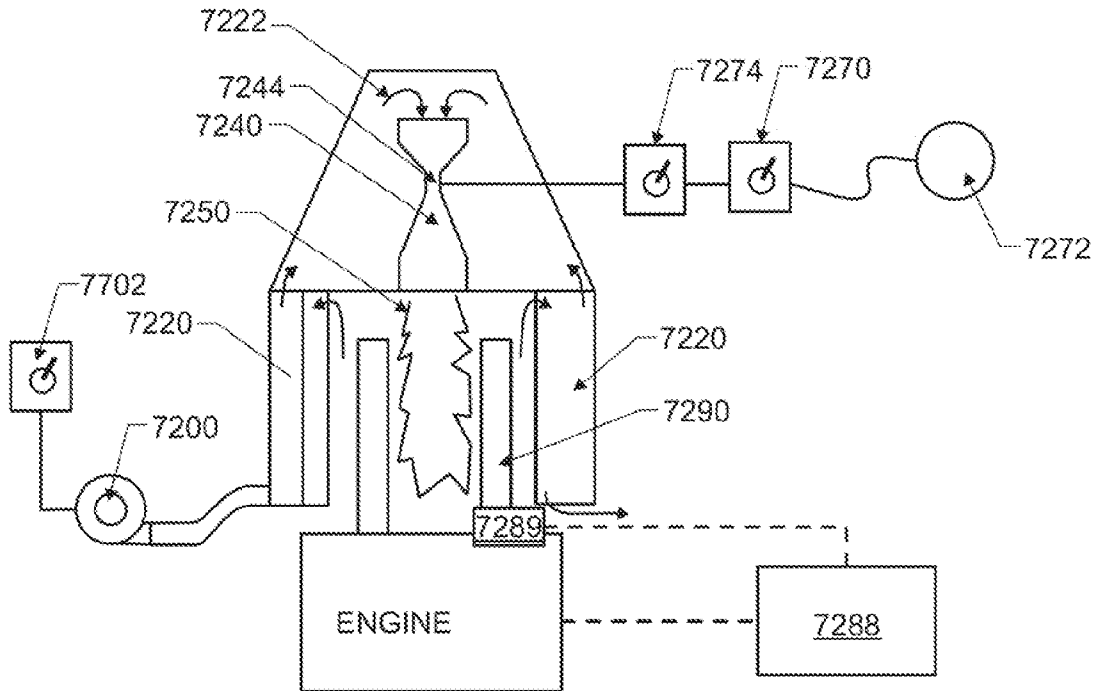

FIG. 77

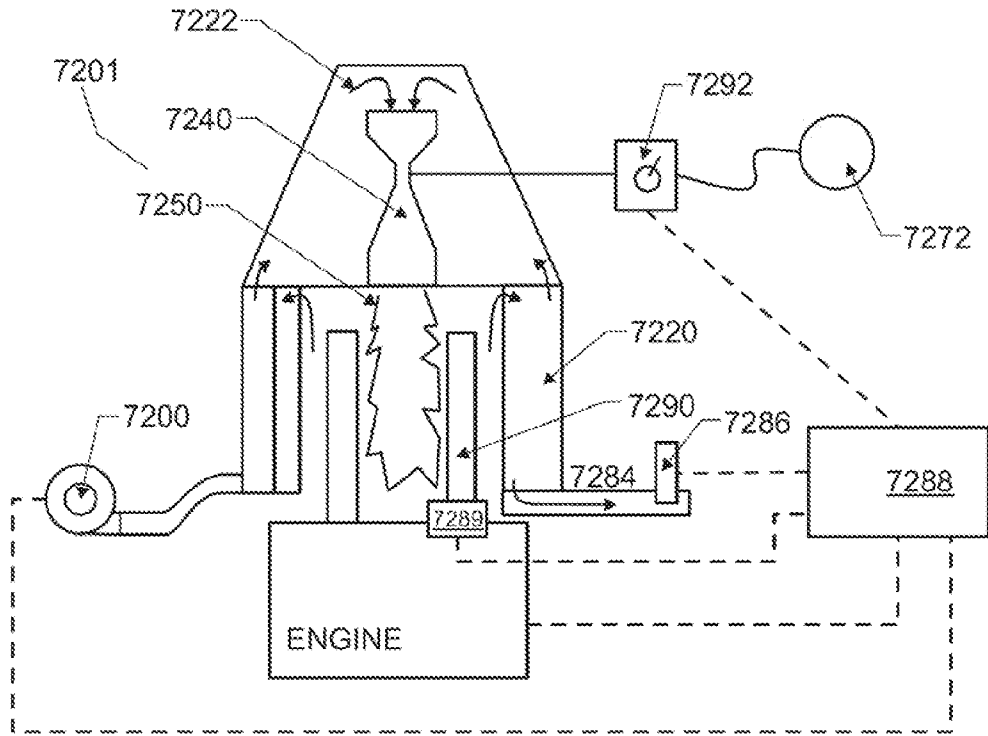

FIG. 78

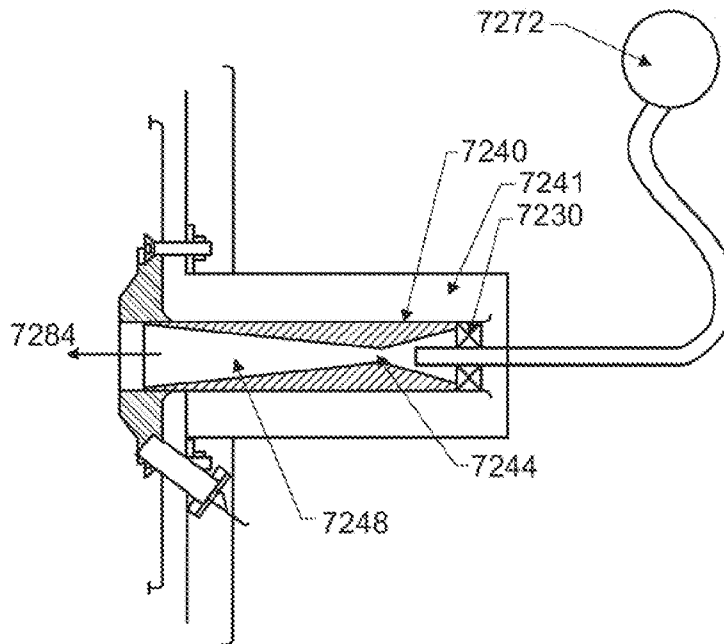

FIG. 79

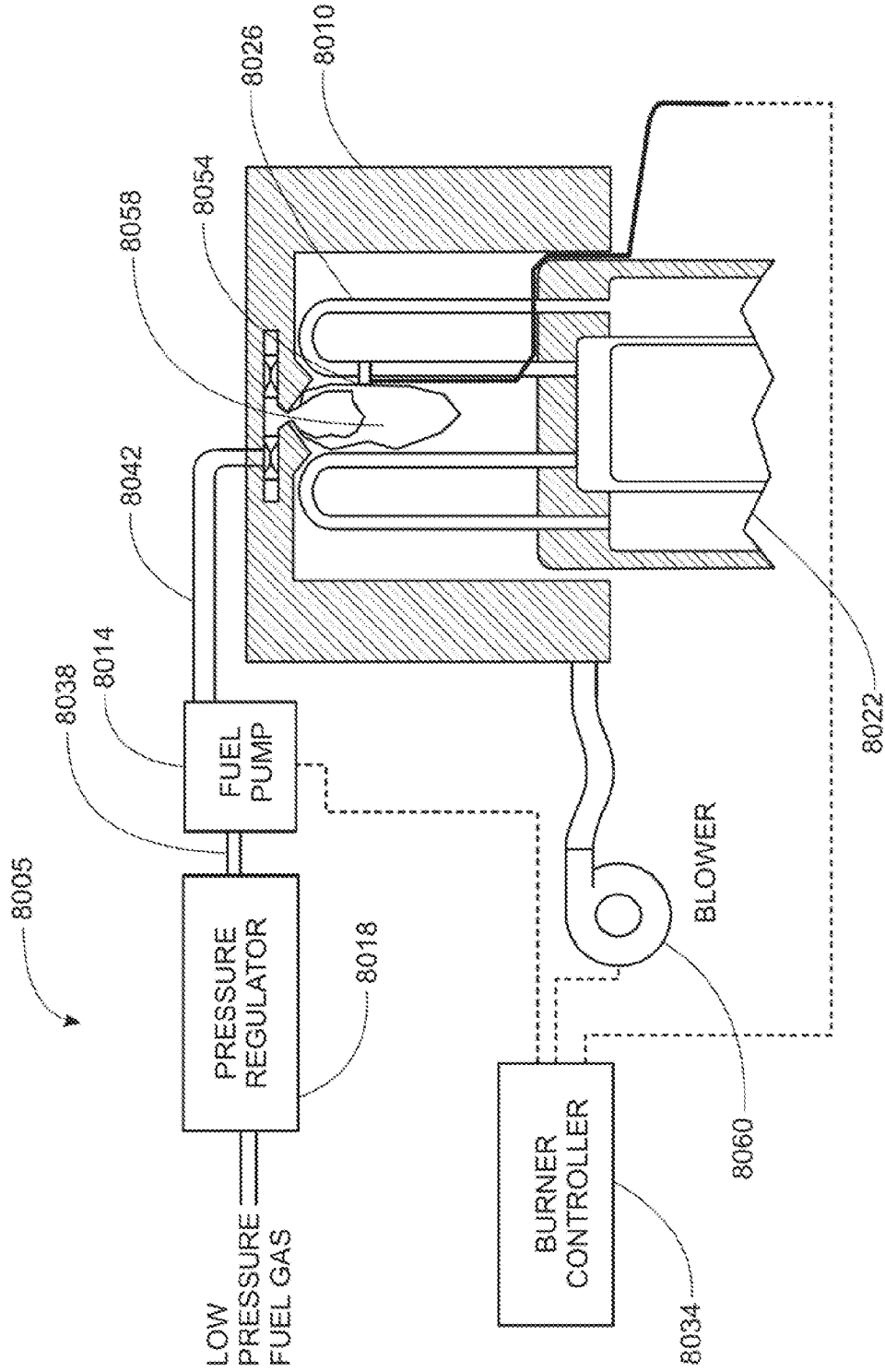

FIG. 80

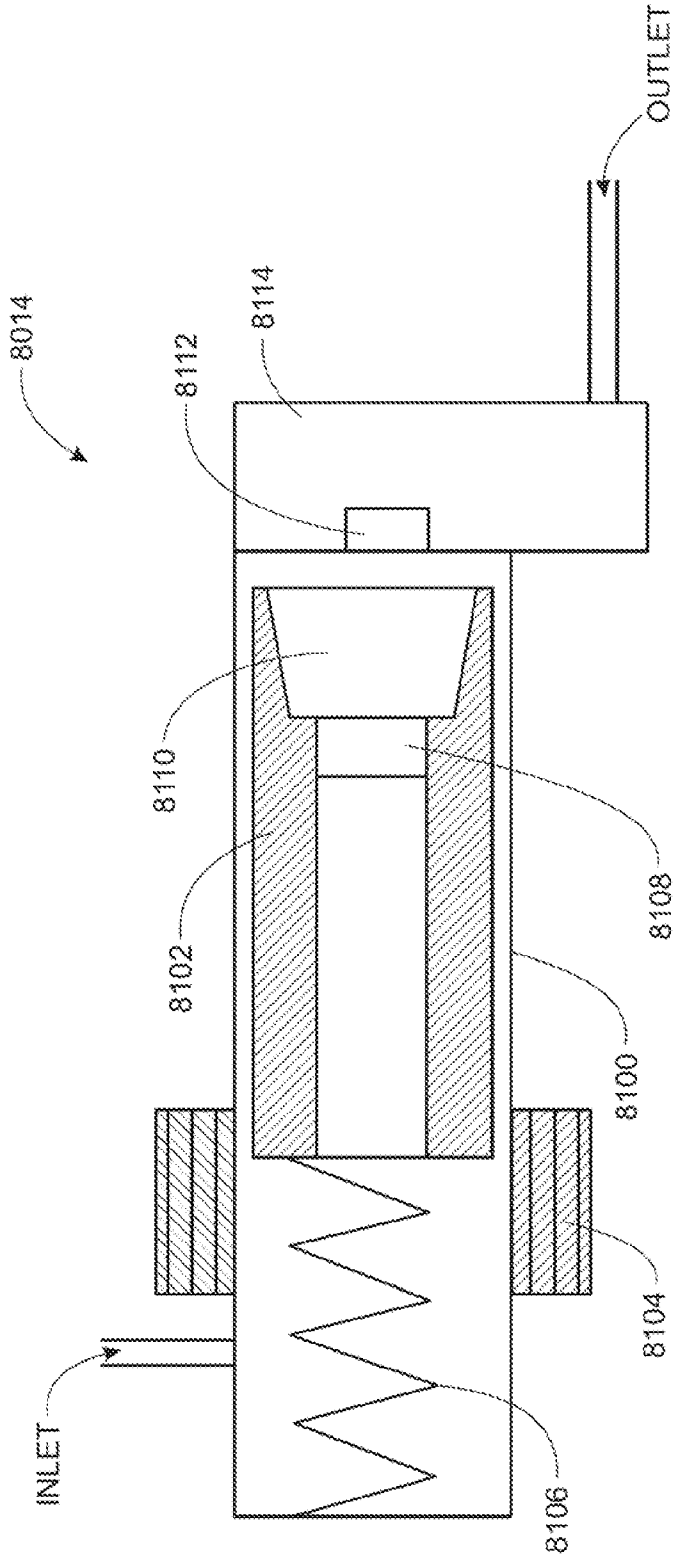

FIG.81

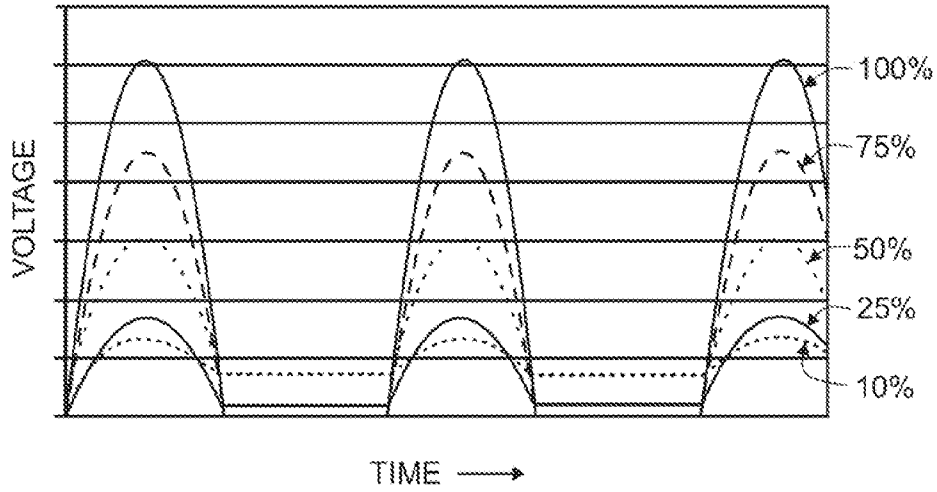

FIG. 82

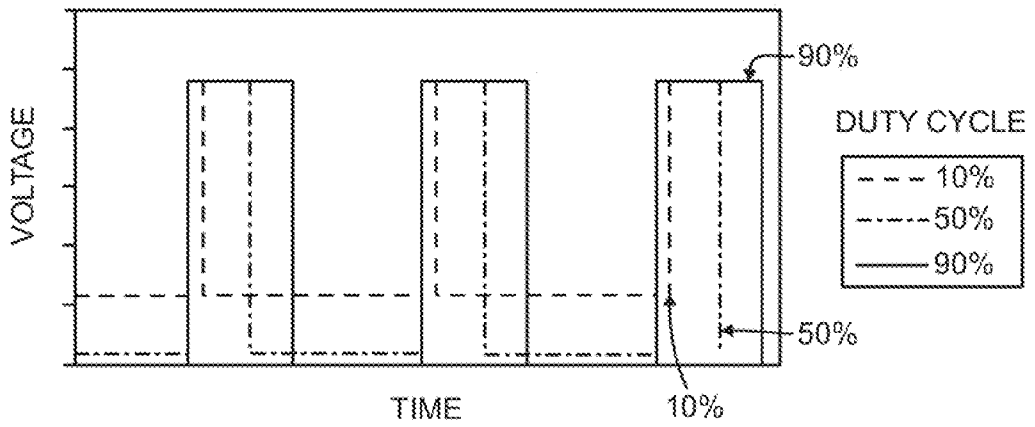

FIG. 83

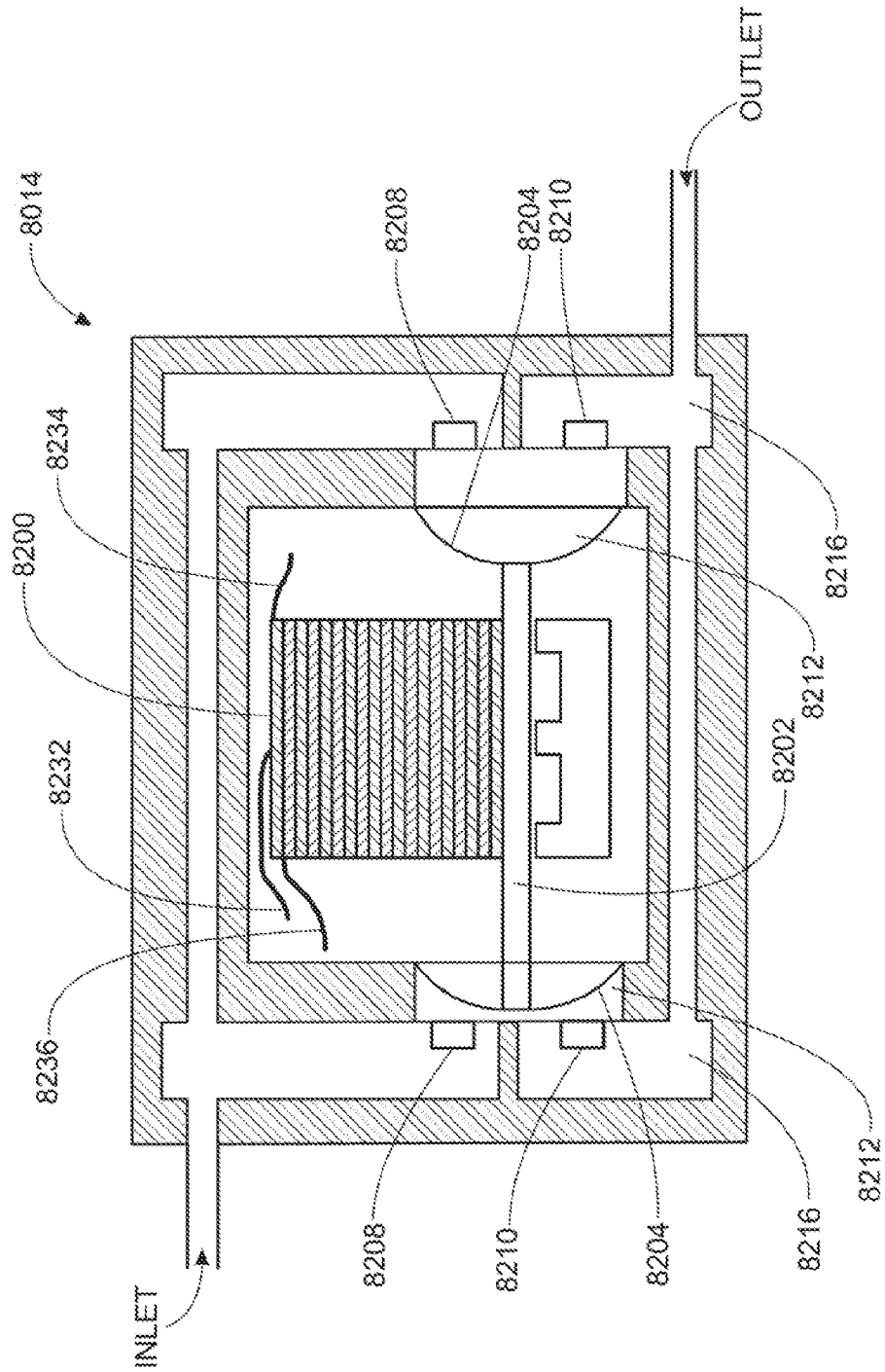

FIG. 84

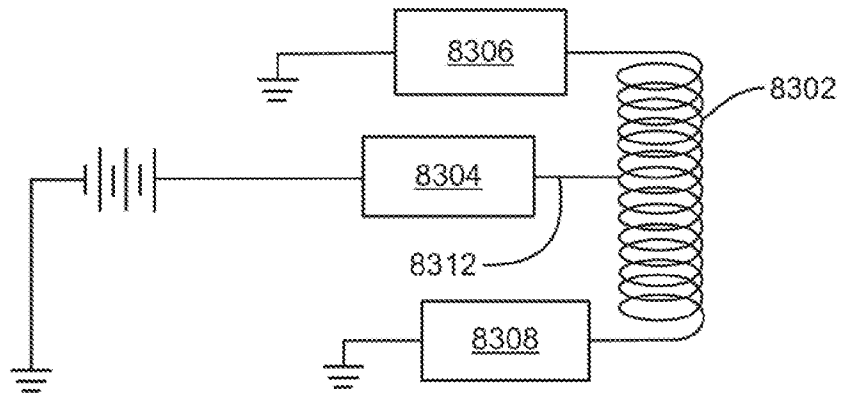

FIG. 85

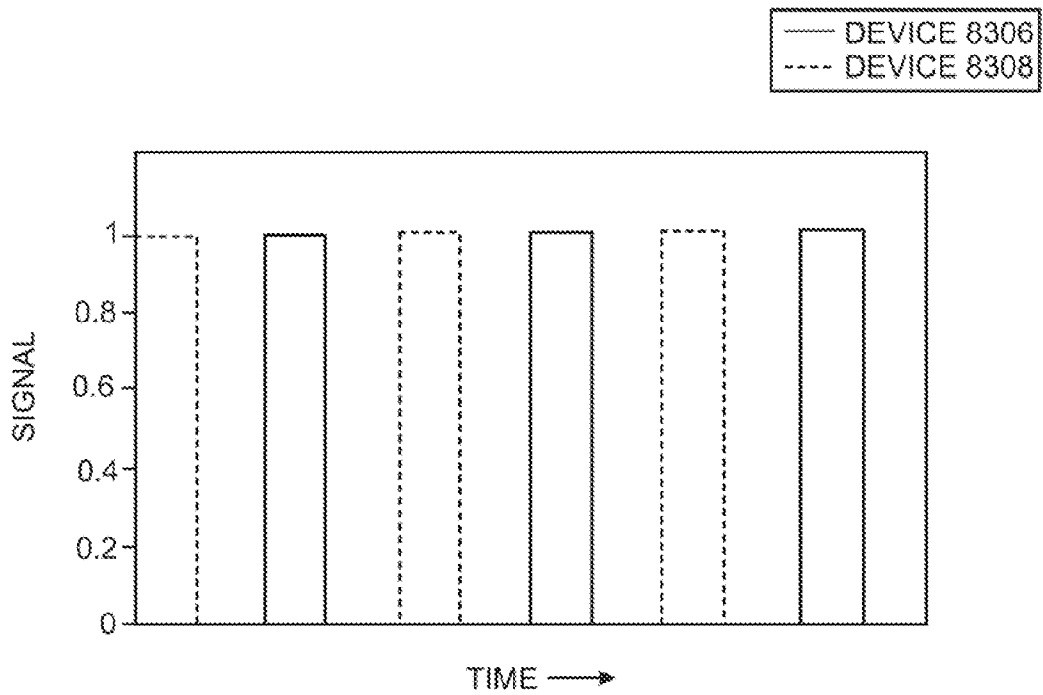

FIG. 86A

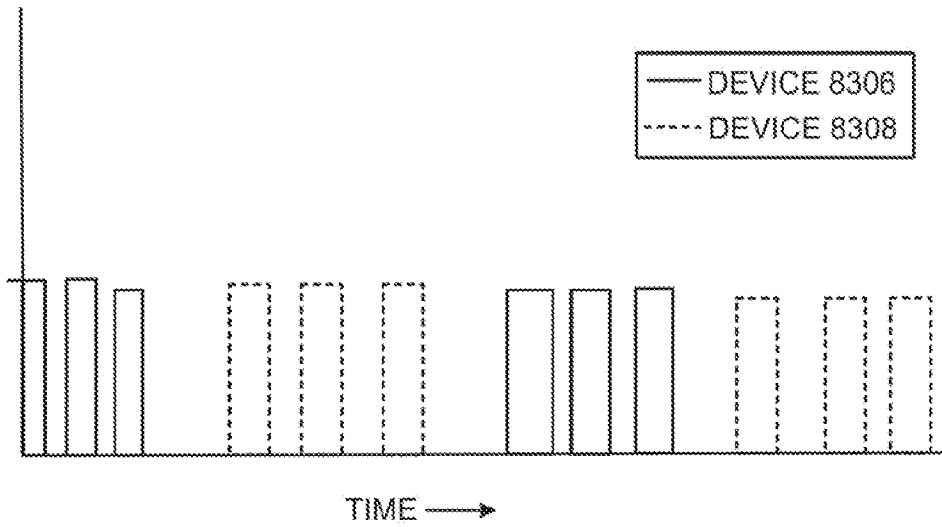

FIG. 86B

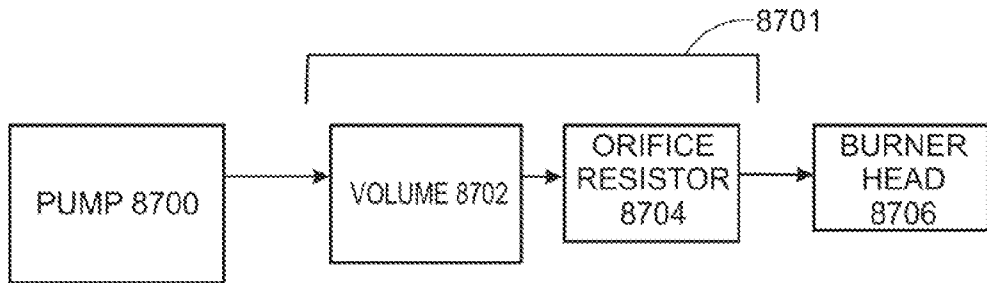

FIG. 87A

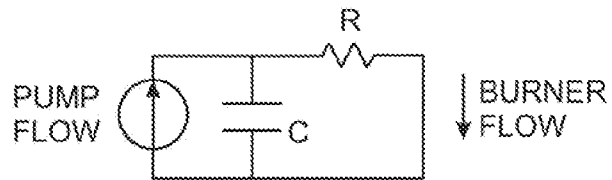

FIG. 87B

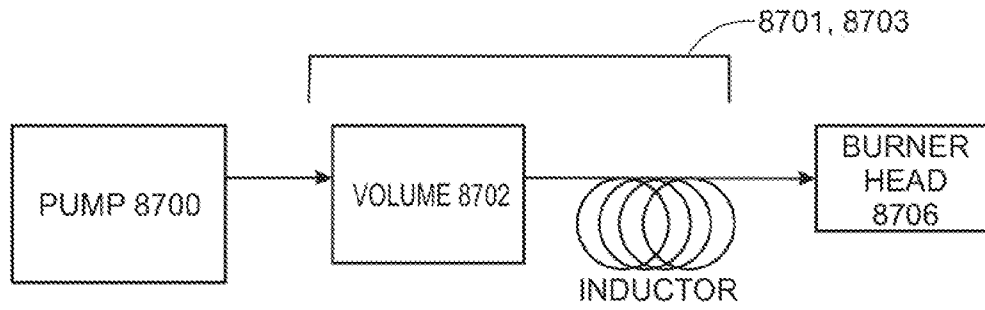

FIG. 87C

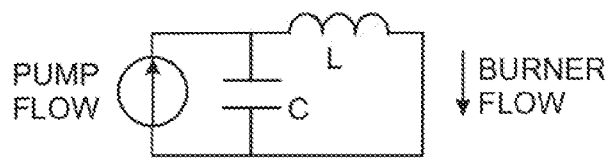

FIG. 87D

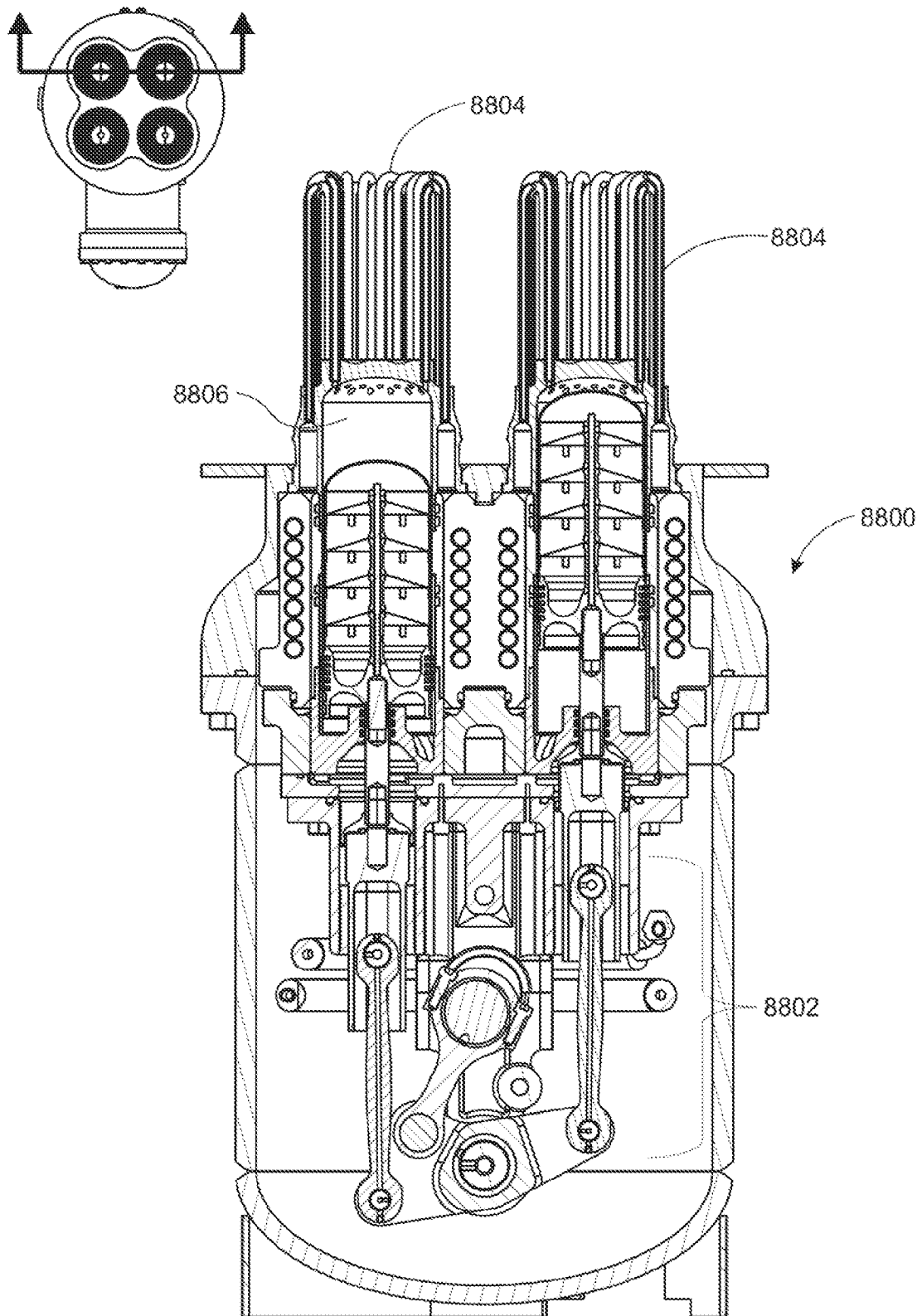

FIG. 88

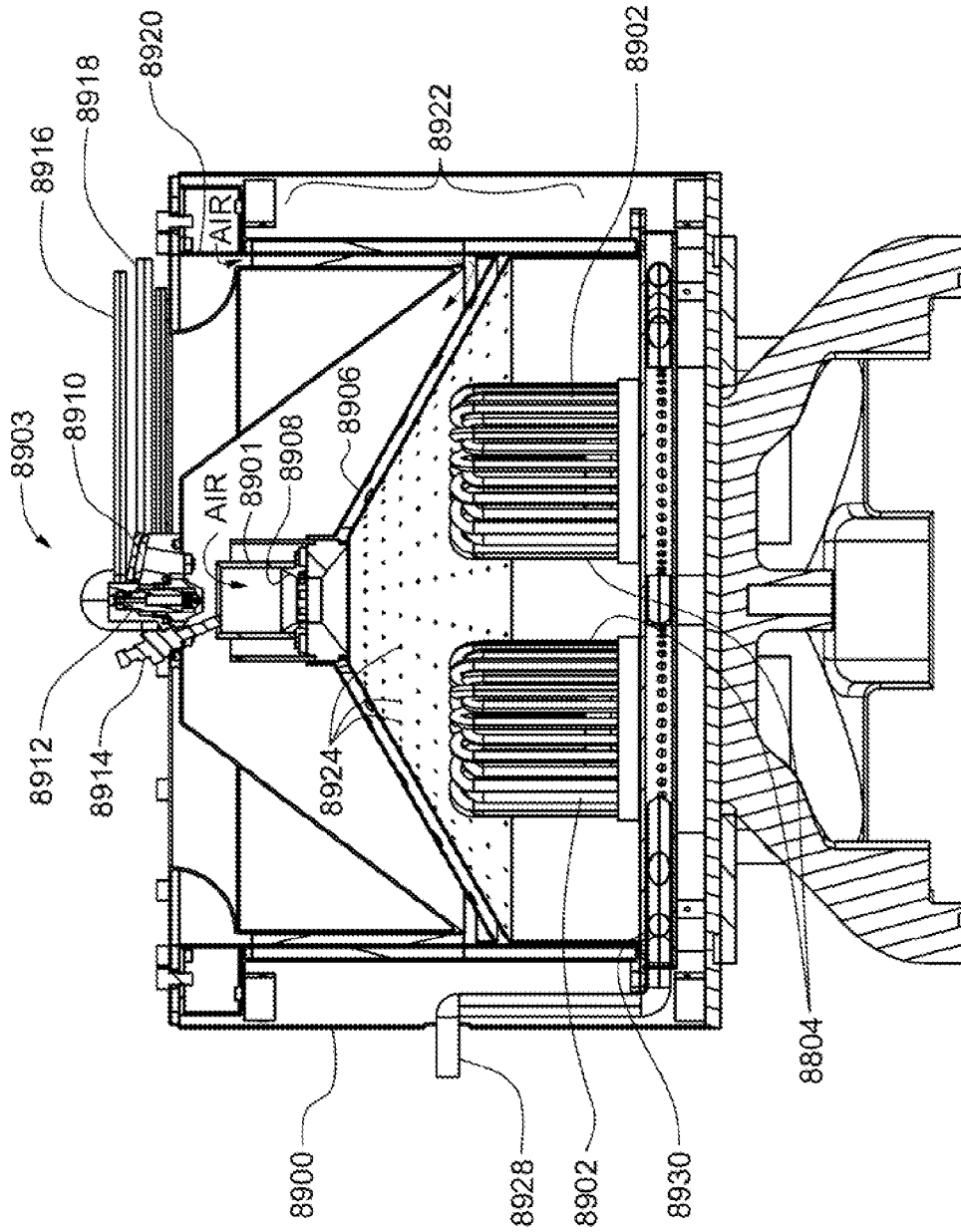

FIG. 89A



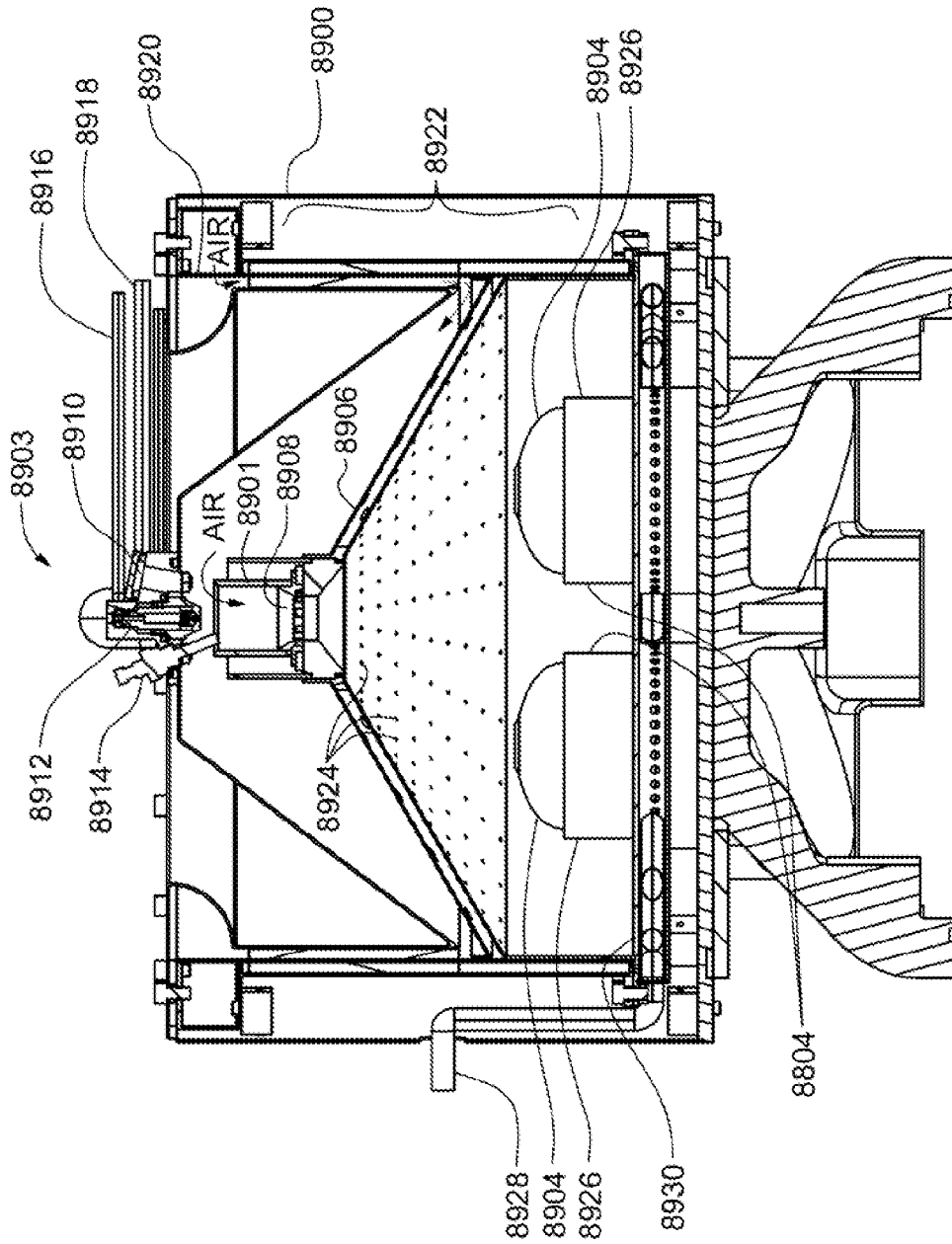

FIG. 89B

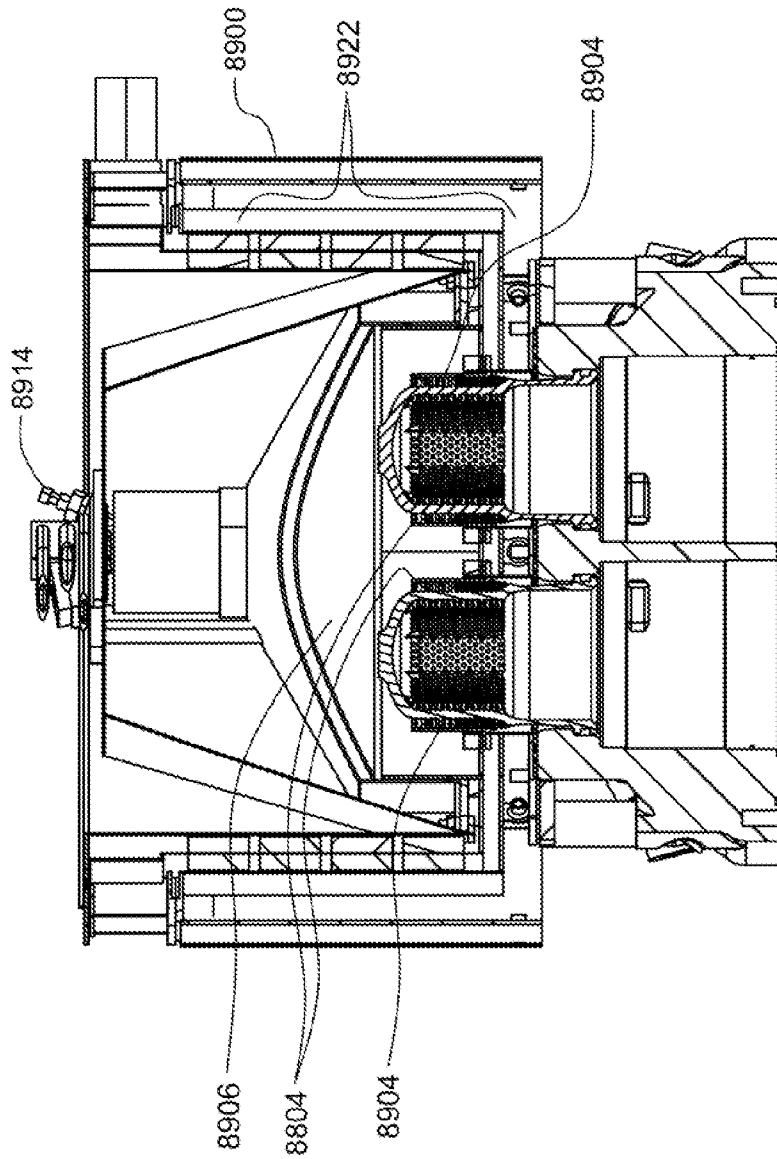

FIG. 89C

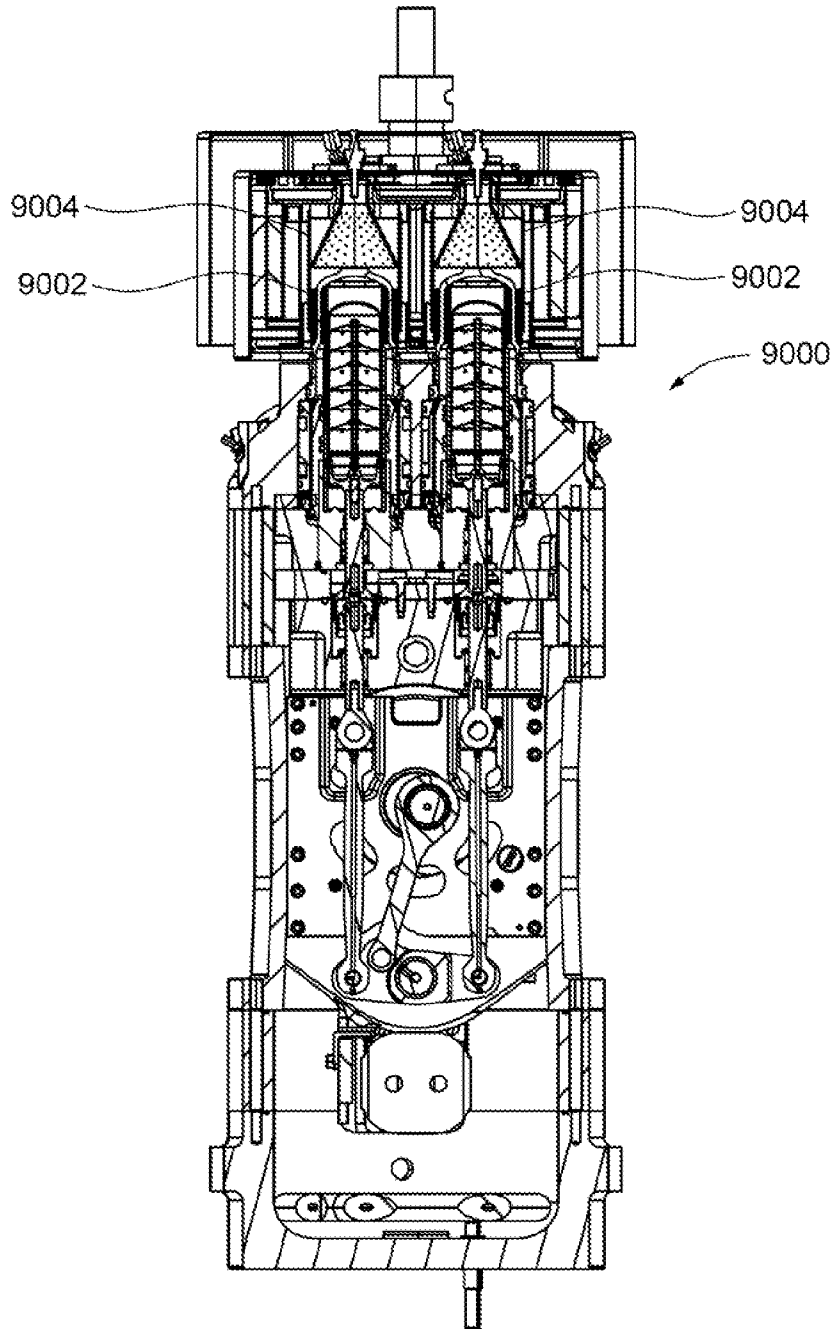

FIG. 90

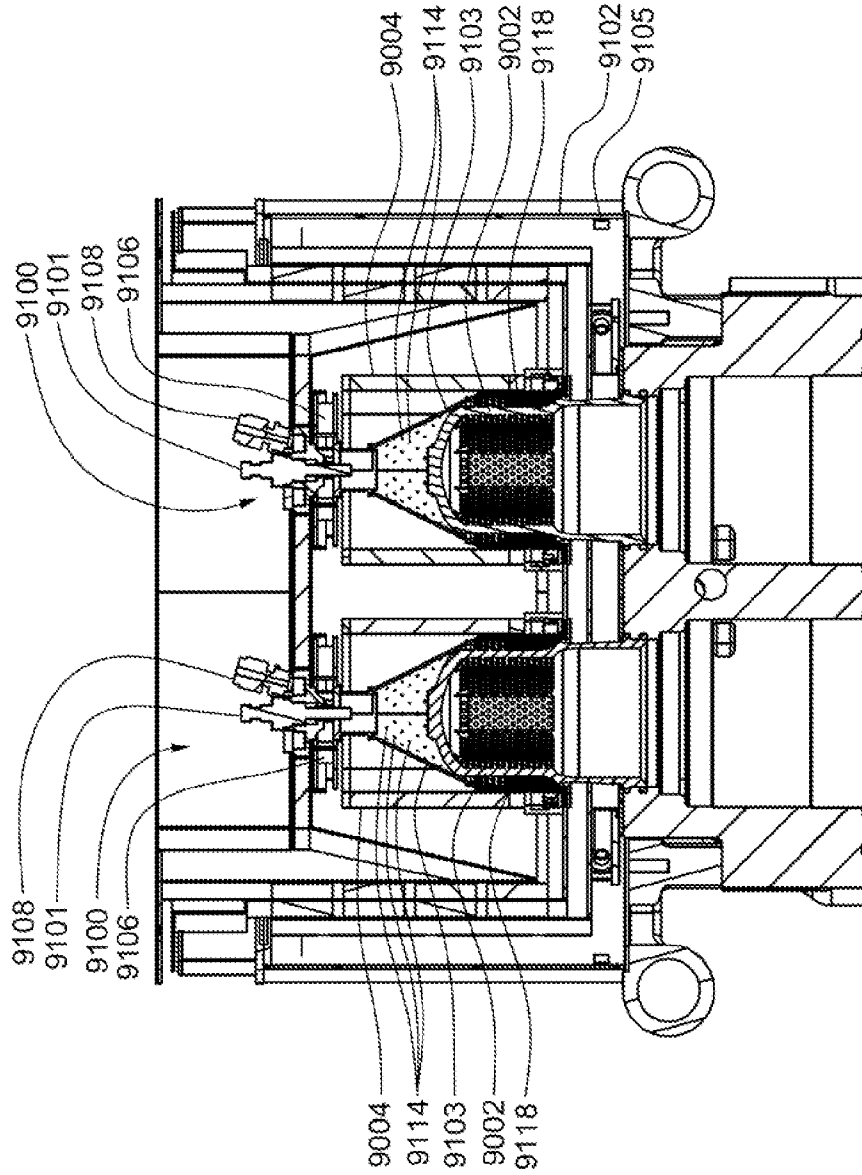

FIG. 91A

+

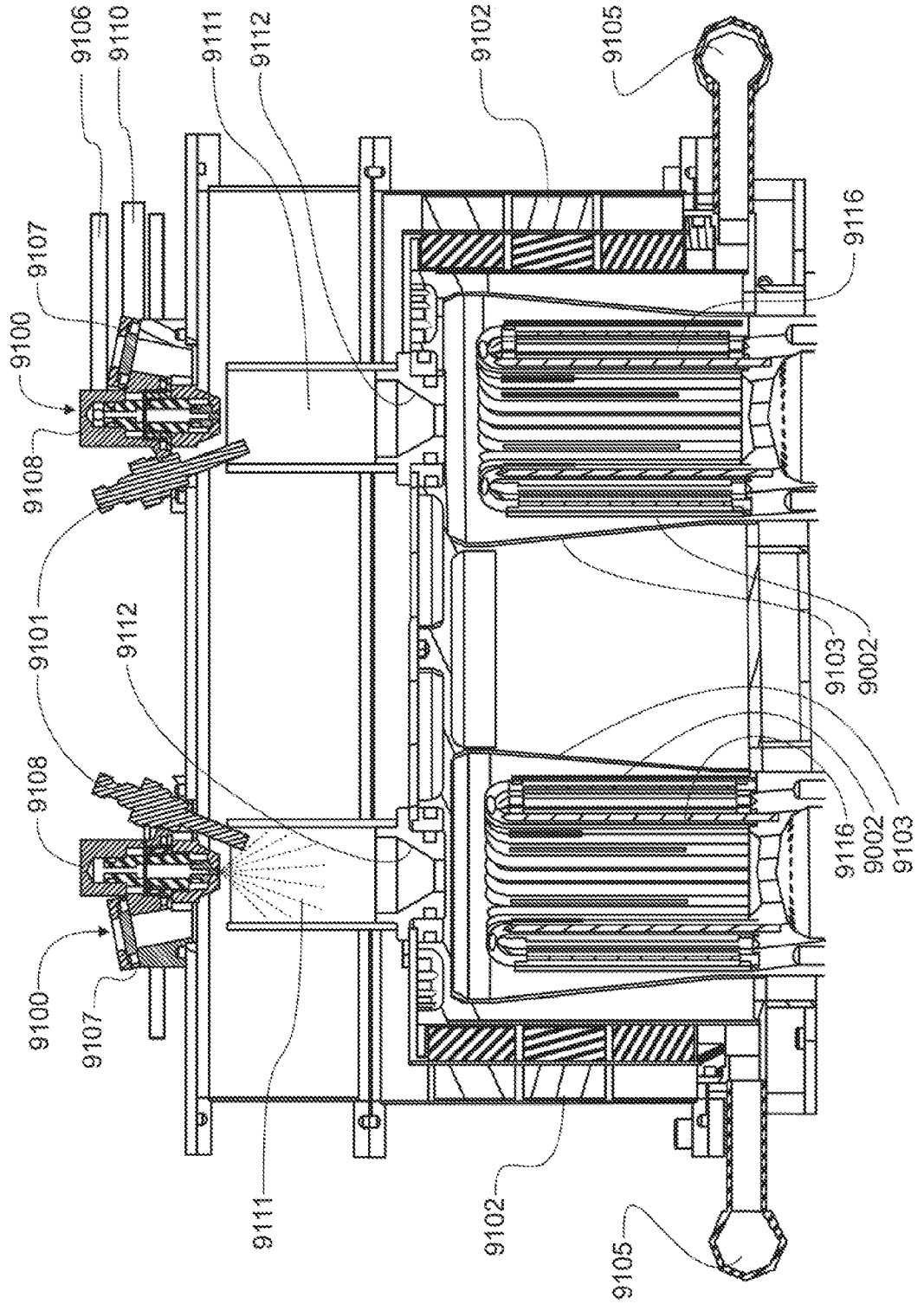

FIG. 91B

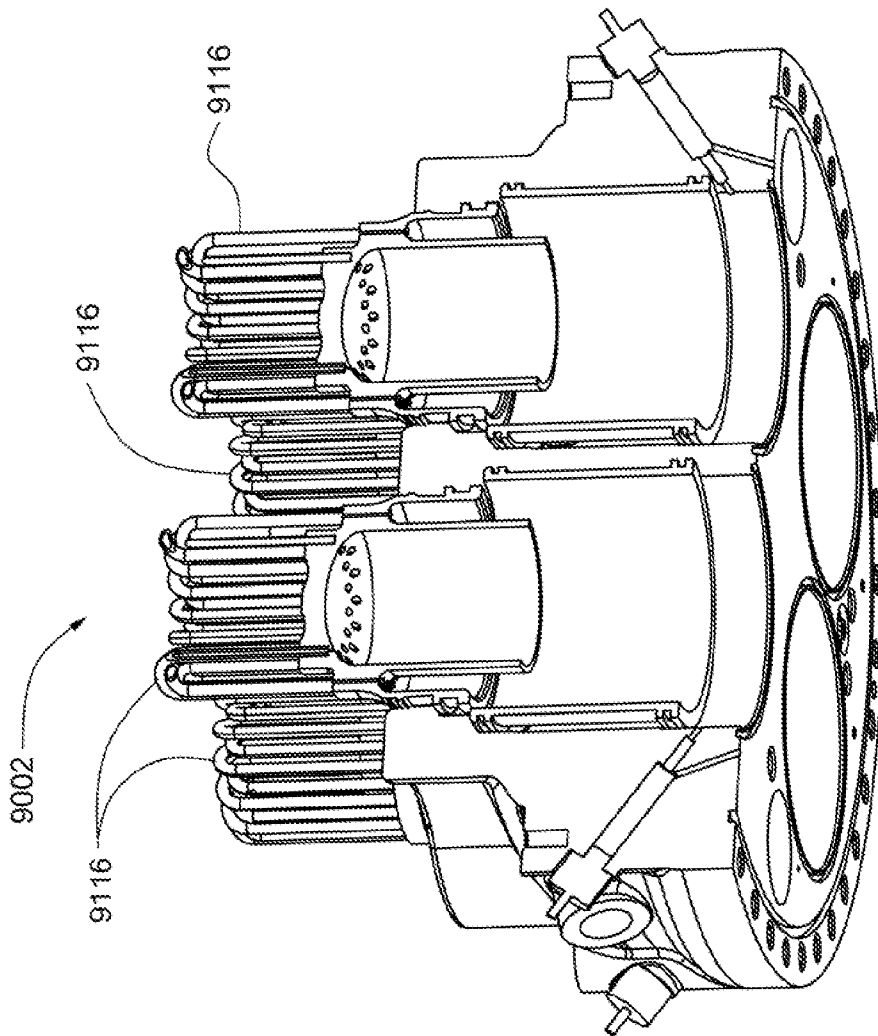

FIG. 91C

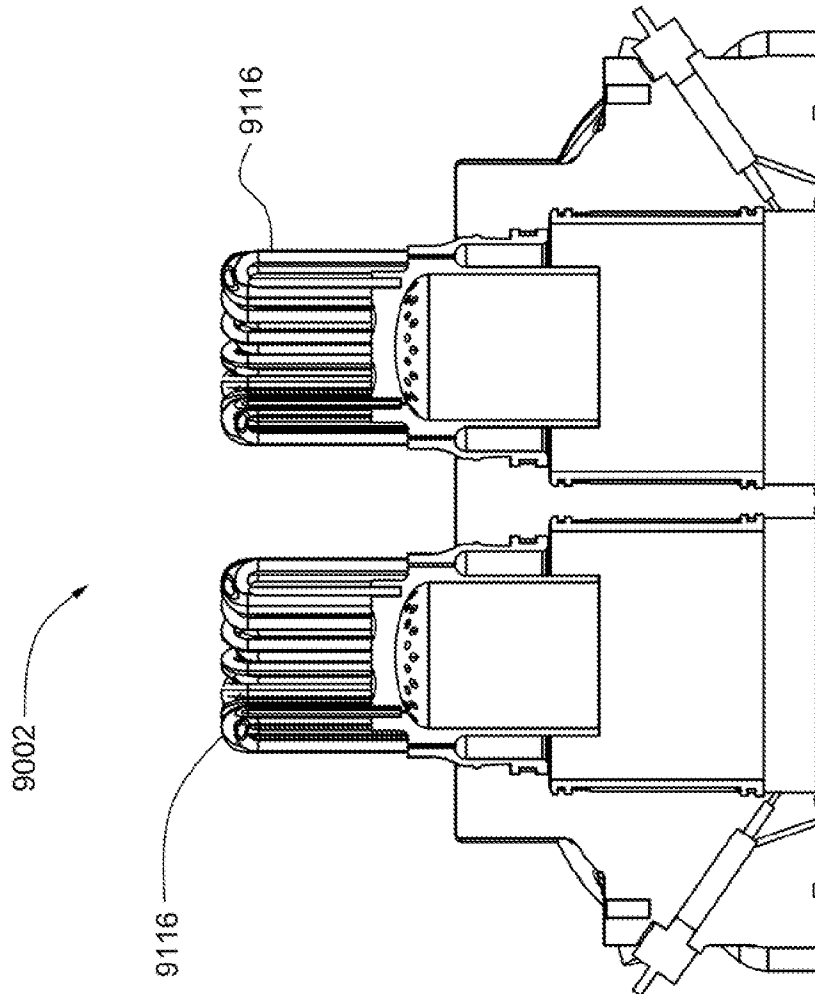

FIG. 91D

# INTERNATIONAL SEARCH REPORT

International application No  
PCT/US2008/060827

**A. CLASSIFICATION OF SUBJECT MATTER**  
INV. F02G1/043

According to International Patent Classification (IPC) or to both national classification and IPC

**B. FIELDS SEARCHED**

Minimum documentation searched (classification system followed by classification symbols)  
F02G F02B

Documentation searched other than minimum documentation to the extent that such documents are included in the fields searched

Electronic data base consulted during the international search (name of data base and, where practical, search terms used)

EPO-Internal

**C. DOCUMENTS CONSIDERED TO BE RELEVANT**

Category*	Citation of document, with indication, where appropriate, of the relevant passages	Relevant to claim No.
X	JP 51 048040 A (UNITED STIRLING AB & CO) 24 April 1976 (1976-04-24)  figures	1-5, 8-10, 12, 14
Y		7, 10, 11
Y		6, 13, 15-23
Y	JP 61 025901 A (AC ENERGI APS) 5 February 1986 (1986-02-05) figures	7, 10, 11
Y	WO 92/09812 A (IST ENGINEERING LTD [IL]; GOLDMUNTZ LAWRENCE [US]) 11 June 1992 (1992-06-11) abstract page 3, paragraph 2 figure 2	6, 13, 15-23
-/--		

Further documents are listed in the continuation of Box C.

See patent family annex.

\* Special categories of cited documents :

- \*A\* document defining the general state of the art which is not considered to be of particular relevance
- \*E\* earlier document but published on or after the international filing date
- \*L\* document which may throw doubts on priority claim(s) or which is cited to establish the publication date of another citation or other special reason (as specified)
- \*O\* document referring to an oral disclosure, use, exhibition or other means
- \*P\* document published prior to the international filing date but later than the priority date claimed

- \*T\* later document published after the international filing date or priority date and not in conflict with the application but cited to understand the principle or theory underlying the invention
- \*X\* document of particular relevance; the claimed invention cannot be considered novel or cannot be considered to involve an inventive step when the document is taken alone
- \*Y\* document of particular relevance; the claimed invention cannot be considered to involve an inventive step when the document is combined with one or more other such documents, such combination being obvious to a person skilled in the art.
- \*&\* document member of the same patent family

Date of the actual completion of the international search

8 October 2008

Date of mailing of the international search report

15/10/2008

Name and mailing address of the ISA/

European Patent Office, P.B. 5818 Patentlaan 2  
NL - 2280 HV Rijswijk  
Tel. (+31-70) 340-2040,  
Fax: (+31-70) 340-3016

Authorized officer

Matray, J

## INTERNATIONAL SEARCH REPORT

International application No

PCT/US2008/060827

C(Continuation). DOCUMENTS CONSIDERED TO BE RELEVANT		
Category*	Citation of document, with indication, where appropriate, of the relevant passages	Relevant to claim No.
A	JP 01 008346 A (TOKYO SHIBAURA ELECTRIC CO) 12 January 1989 (1989-01-12) figure 1	15-23
X	JP 57 018443 A (NISSAN MOTOR) 30 January 1982 (1982-01-30) abstract figure 1	1-5,9, 10,12,14
Y	JP 61 040450 A (MITSUBISHI ELECTRIC CORP) 26 February 1986 (1986-02-26) abstract figures	6,13
X	US 4 415 171 A (EDWARDS LINTON A [US]) 15 November 1983 (1983-11-15) figure 12	1,2
A		3-23
X	GB 2 249 131 A (FORD MOTOR CO [GB]) 29 April 1992 (1992-04-29) figure 1	1,2
A	FR 2 459 371 A (ECA ECA [FR]) 9 January 1981 (1981-01-09) page 8, lines 17-28 figures 1-4	1-22

## INTERNATIONAL SEARCH REPORT

Information on patent family members

International application No

PCT/US2008/060827

Patent document cited in search report		Publication date	Patent family member(s)	Publication date
JP 51048040	A	24-04-1976	JP 929454 C JP 53009672 B	17-10-1978 07-04-1978
JP 61025901	A	05-02-1986	NONE	
WO 9209812	A	11-06-1992	AU 9086691 A US 5195320 A	25-06-1992 23-03-1993
JP 1008346	A	12-01-1989	NONE	
JP 57018443	A	30-01-1982	NONE	
JP 61040450	A	26-02-1986	JP 1776314 C JP 4063225 B	28-07-1993 09-10-1992
US 4415171	A	15-11-1983	NONE	
GB 2249131	A	29-04-1992	NONE	
FR 2459371	A	09-01-1981	JP 1379483 C JP 56050238 A JP 61048625 B SE 443629 B SE 8004468 A US 4335884 A	28-05-1987 07-05-1981 24-10-1986 03-03-1986 19-12-1980 22-06-1982