

(19) World Intellectual Property Organization
International Bureau



(43) International Publication Date
13 December 2001 (13.12.2001)

PCT

(10) International Publication Number
WO 01/95616 A2

(51) International Patent Classification⁷: H04N 5/445

(21) International Application Number: PCT/GB01/02500

(22) International Filing Date: 7 June 2001 (07.06.2001)

(25) Filing Language: English

(26) Publication Language: English

(30) Priority Data:
0013922.0 7 June 2000 (07.06.2000) GB

(71) Applicant (for all designated States except US): GEMSTAR DEVELOPMENT LIMITED [GB/GB]; 14 Blacklands Terrace, London SW3 2SP (GB).

(72) Inventor; and

(75) Inventor/Applicant (for US only): DRAZIN, Jonathan [GB/GB]; Gemstar Development Limited, 14 Blacklands Terrace, London SW3 2SP (GB).

(74) Agents: KINSLER, Maureen, Catherine et al.; Kilburn & Strode, 20 Red Lion Street, London WC1R 4PJ (GB).

(81) Designated States (national): AE, AG, AL, AM, AT, AU, AZ, BA, BB, BG, BR, BY, BZ, CA, CH, CN, CO, CR, CU, CZ, DE, DK, DM, DZ, EE, ES, FI, GB, GD, GE, GH, GM, HR, HU, ID, IL, IN, IS, JP, KE, KG, KP, KR, KZ, LC, LK, LR, LS, LT, LU, LV, MA, MD, MG, MK, MN, MW, MX, MZ, NO, NZ, PL, PT, RO, RU, SD, SE, SG, SI, SK, SL, TJ, TM, TR, TT, TZ, UA, UG, US, UZ, VN, YU, ZA, ZW.

(84) Designated States (regional): ARIPO patent (GH, GM, KE, LS, MW, MZ, SD, SL, SZ, TZ, UG, ZW), Eurasian patent (AM, AZ, BY, KG, KZ, MD, RU, TJ, TM), European patent (AT, BE, CH, CY, DE, DK, ES, FI, FR, GB, GR, IE, IT, LU, MC, NL, PT, SE, TR), OAPI patent (BF, BJ, CF, CG, CI, CM, GA, GN, GW, ML, MR, NE, SN, TD, TG).

Published:

— without international search report and to be republished upon receipt of that report

For two-letter codes and other abbreviations, refer to the "Guidance Notes on Codes and Abbreviations" appearing at the beginning of each regular issue of the PCT Gazette.

(54) Title: AN ENHANCED TELEVISION SYSTEM

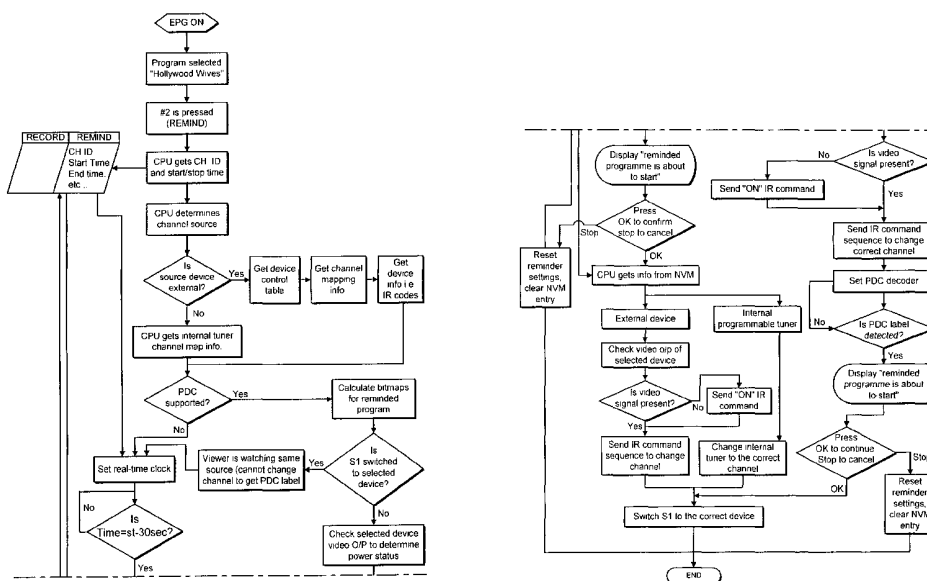

(57) Abstract: A controller for a television system comprising software for determining from a label memory whether a label, such as a VPS or PDC label, indicative of the real start time of a selected program is to be transmitted. If it is determined that labels are to be transmitted, the controller is primed to receive those labels at a pre-determined time. In response to receipt of the label, a prompt reminding the viewer of the transmission of the selected television program is generated. In the event that it is determined that VPS or PDC or the like is not supported by the channel on which the selected program is to be transmitted, a real time clock is monitored and a short time before the scheduled time for transmission, a prompt reminding the viewer of the television program is generated.

WO 01/95616 A2

AN ENHANCED TELEVISION SYSTEM

The present invention relates to a television system, in particular a system for allowing enhanced control of a television and peripheral devices such as video recorders and/or set top boxes.

As is well known, televisions include a tuner for receiving television signals from terrestrial broadcast sources. Increasingly, however, viewers have access to additional television channels beyond those that can be received by the tuner in their television, using for example set top boxes. In addition, it is also becoming more common for viewers to have access to other video source devices such as digital video discs (DVDs). Whilst the advent of these external devices provides viewers with many more viewing options, they have resulted in an increasing level of complexity, which is disadvantageous. Particular problems arise when viewers want to record television programs.

Various arrangements are known for allowing video signals from different external source devices to be recorded. For example, the devices can be directly connected to a video recorder using additional input ports on the recorder, commonly via the SCART connection in Europe, as shown in Figure 1. However, when the external devices are connected to the video recorder in this way, user initiated recording, whether manual or via a video recorder timer, is complicated because the viewer must correctly identify the input source when adjusting the video recorder's recording settings. Frequently the viewer either forgets to do so or makes a wrong selection. This is a disadvantage.

Another example of how external source devices can be connected to a video recorder is shown in Figure 2. In this case, signals from the external source devices are routed to the video recorder through the television. In this case, in order to record a television program, the viewer is required to manipulate two remote control units: one to set up the video recorder and a second to switch the TV's input to the correct source device. This is usually impractical in cases where multiple recordings across different STB sources need to be timed automatically. The result is that viewers seldom record channels received via STBs because the process is too complicated and unreliable.

Viewers also encounter difficulties recording programs at the right time because their broadcast times may differ from the scheduled times. The inconvenience of departures from scheduled times is most evident when setting a video recorder to make automatically timed recordings, in particular unattended recording. In such cases, the video recorder can fail to record the whole of a programme because it has been programmed with an incorrect start and finish record time.

Another common problem with video recorder record timing is due to the video recorder clock being incorrectly set by the user, or due to it losing its time as a result of, for example, a power interruption. Many channels broadcast timing data packets in one of the vertical blanking interval (VBI) of their TV picture to help alleviate both types of problem. These packets contain time sensitive labels that, among other things, identify the beginning and end points of a broadcast TV program broadcast. This type of packet is widely broadcast in

Europe according to the public PDC and VPS broadcast specifications and many video recorders are adapted to receive and recognise these signals. However, while PDC timing is a good solution in theory, there are nevertheless limitations. This is because for a given country, PDC is not always uniformly
5 adopted by every channel and, depending on whether a channel is or is not PDC supported, viewers must either set their video recorders to wait for the PDC labels or record according to the video recorder's built-in clock. Many viewers do not know whether PDC is supported by the channel they want to record. If they mistakenly select the PDC feature when it is not supported, the result can
10 be that nothing is recorded at all.

As the number of channels available in home television systems increases, viewers benefit from being reminded that a desired program is about to start on another channel. Some systems include a facility for operating an on-screen
15 reminder for viewers. Upon response to such a reminder, the television automatically changes to the desired channel at its start time. However, in such systems similar problems arise as those experienced when viewers attempt to record television programs. Namely, the TV must have an accurate means to determine when the program is starting and must provide a viewer friendly
20 means to select the desired channel on an external set-top box.

The increasing use of set-top-boxes that receive digital and/or pay cable, satellite and terrestrial TV channels has resulted in further problems. For a number of reasons, set top boxes and video-recorders are frequently left
25 switched on unnecessarily when not in use. Often viewers cannot be bothered with the inconvenience of having to switch on a set-top box each time they view

a channel from it and having to remember to switch it off afterwards.

Moreover, they cannot easily determine visually which power mode a set-top box or video recorder is in because the segment display is either too small, or because the set-top box or video recorder is hidden in a cabinet. Because of this, set-top box and video recorder owners frequently face unnecessarily high electricity costs, with the consequential damage to the environment that results.

Another problem with known television systems is that it can be difficult to reliably download data from a remote location. This is done, for example, to provide information for constructing an electronic program guide (EPG). Such guides are frequently provided in order to simplify the use of television systems. These guides display listings of television programs that are available to the user. Selection of a currently broadcast program in the listing, generally causes the television tuner to change to the selected channel.

EPG data, such as TV listings data, news information, advertising and control parameters, are sometimes broadcast in the vertical blanking interval (VBI) in a number of channels. Such channels are referred to here as "EPG host" channels. Normally a TV has a single tuner which, when tuned by a viewer to a channel for TV viewing purposes, is unavailable for downloading data from an EPG host. This is, however, a problem because it means that it is not possible for the viewer to receive last minute updates of TV schedule changes or last minute news, such as weather or sports results. This is a disadvantage.

An object of the present invention is to provide a simple means of recording or being reminded of television programs that are provided from more than one television signal source device.

Another object of this invention is to provide a television system that reduces power consumption of unused external video source devices.

- 5 Yet another object of this invention is to provide a television system that enables the viewer to receive up to date information, whilst viewing the television.

According to a first aspect of the present invention, there is provided a method
10 for controlling a television system comprising: storing in a memory information relating to a selected television program, including a channel on which it is to be transmitted and a scheduled start time; storing in a label memory information on a plurality of channels on which are transmitted labels that are indicative of real start times of television programs; determining from the label memory
15 whether a label indicative of the real start time of the selected program is to be transmitted, using the channel information; allowing receipt of the label, in the event it is determined that a label is to be transmitted, and enabling a control function in response to receipt of the label or, in the event that a label is not to be transmitted, at substantially the scheduled start time stored in memory, as
20 measured by a real time clock.

Using this method, it is automatically determined, from a label memory, whether or not the channel on which the selected television program is to be broadcast transmits labels that are indicative of the start times of television
25 programs. If it is determined that labels are transmitted on the selected channel,

6

the system responds accordingly. If, however, it is determined that labels are not to be transmitted on that channel, the system relies on the real time clock and the scheduled time of transmission to determine when action has to be taken. This means that the viewer does not have to be concerned with checking
5 which channels support labels such as VPS or PDC and reduces the likelihood of errors. This is advantageous and solves a long term problem in the industry of how to simplify and improve the accuracy of such systems.

Preferably, the details of the selected program include a stop time.

10

Preferably, the method further involves using the start time of the selected program to calculate the labels. The labels may be PDC or VPS recording control command signals (as described in public standard ETS 300 231) or an event ID (such as described in public standard ETS 300 468) whose broadcasts
15 are synchronised to mark the actual beginning, duration or end of a TV program's broadcast.

The step of enabling may involve generating an interactive prompt. The method may then further involve receiving a response from a viewer indicative
20 of whether the viewer wants to view the program, whereby on receipt of a positive response to the prompt the method may further involving causing the television system automatically to switch to the selected program.

When the television system has a plurality of different television source
25 devices, preferably, the method further involves selectively connecting one of

the television sources devices to an on screen display generator and selectively connecting another of the television sources devices to a data decoder.

Preferably, the data decoder is a teletext or P.31 decoder and/or a PDC/VPS decoder. An advantage of this is that the system can display a program received
5 from one source device, whilst simultaneously processing data from another source device.

According to another aspect of the present invention, there is provided a controller for a television system comprising: a memory for storing information
10 relating to a selected television program, including a channel on which it is to be transmitted and a scheduled start time; a label memory for storing information on channels on which are transmitted labels that are indicative of a real start of a television program; means for determining from the label memory whether a label indicative of the real start time of the selected program is to be
15 transmitted; means for allowing receipt of the label, in the event it is determined that a label is to be broadcast, and enabling means for enabling a control function relating to the selected television program in response to receipt of the label or, in the event that a label is not to be transmitted, at substantially the scheduled start time stored in memory, as measured by a real time clock.

20

Means are provided for calculating the label using the original announced start date and time of the selected program if it is a PDC or a VPS label.

The means for enabling may be operable to generate an interactive prompt.

25 Means may be provided for receiving a response from a viewer indicative of whether the viewer wants to view the program. Preferably, means are provided

for automatically causing the selected program to be displayed on receipt of a positive response to the prompt.

The television system may include a plurality of different television signal source devices. Preferably, the controller has means, for example a switch, for selectively connecting each of the television sources devices to an on screen display generator. This is advantageous as it means that the controller can automatically connect a selected one of the television sources to the display.

Preferably, the controller has means, for example a switch, for selectively connecting each of the television sources devices to a data decoder. Preferably, the data decoder is a teletext or P.31 decoder and a PDC/VPS decoder. This is advantageous because it means that whilst a viewer is watching one channel received from one source, the controller can monitor data, such as start labels, that are transmitted on channels from other source devices.

Preferably, the controller has means, for example a switch, for selectively connecting each of the television sources devices to a video recorder. Preferably, the video recorder is a video cassette recorder, PVR or a DVD recorder or any like device. This is advantageous because it means that whilst a viewer is watching one channel received from one source, the recorder can record signals transmitted on channels from other source devices.

Preferably, an emulator responsive to a single universal remote control is provided for controlling the television system, whereby signals sent to the

emulator from the remote control are converted to signals that are recognisable by all source devices of the system. This is advantageous as it means that the user only has to interact with a single remote control.

5 Preferably, means are provided for generating an electronic program guide for displaying television program listings. The guide may be presented in a grid format. In this way, the viewer can make program selections merely by highlighting a selected box in the grid.

10 Means are preferably provided in the guide for activating a remind facility. For example, receipt of a pre-determined signal from a remote control, preferably, a universal remote control, may indicate that a viewer wishes to be reminded when a program is to be broadcast. Receipt of this signal preferably causes the details of the selected program, including a channel on which it is to be
15 broadcast and start and stop times, to be stored in memory.

According to a further aspect of the present invention, there is provided a computer program, preferably on a data carrier or some other computer readable medium, comprising instructions for storing in a memory information relating
20 to a selected television program, including a channel on which it is to be transmitted and a scheduled start time; storing in a label memory information on channels on which are transmitted labels that are indicative of a real start of a television program; determining from the label memory whether a label indicative of the real start time of the selected program is to be transmitted;
25 generating control signals to enable receipt of the label, in the event it is determined that a label is to be broadcast, and enabling a control function

relating to the selected television program in response to receipt of the label or, in the event that a label is not to be transmitted, at substantially the scheduled start time stored in memory, as measured by a real time clock.

5 According to a yet further aspect of the present invention, there is provided a method of controlling a television system that includes a television tuner and a video recorder comprising storing details of a selected program, including a channel on which it is to be broadcast and a start time; monitoring time using a real time clock; checking the stored program details to identify which channel
10 number the selected program is to be broadcast on; determining whether labels indicative of the start of the selected program are to be broadcast prior to the broadcast of the selected program; if it is determined that start labels are to be broadcast, switching to the relevant channel and waiting until these labels are received or if it is determined that labels are not to be broadcast, waiting until
15 just before the stored time, and causing the video recorder to record the desired program. Preferably, the details of the selected program additionally include a stop time.

The labels may be PDC or VPS labels, or some other real time data label that
20 accurately signifies when the program is actually being broadcast. Preferably, the method further involves using the start time of the selected program to calculate the PDC or VPS labels.

The method may further involve generating a prompt to advise the viewer if the
25 tuning device for the program to be recorded is in use. The prompt may be interactive. The method may then further involve receiving a response from a

viewer indicative of whether the viewer wants to proceed with the recording, whereby on receipt of a positive response to the prompt the video recorder is caused to record the program.

- 5 The method may further involve powering up pre-determined components at a predetermined time prior to the stored start time.

The method may also involve determining whether the video recorder is already being used and if so generating and displaying a warning message and prompt,
10 e.g. "Recording is about to start – press OK to continue, STOP to cancel". If the viewer responds with STOP, the record process is aborted. If the viewer responds with OK, the method proceeds to the step of causing the video recorder to record.

- 15 In order to cause the video recorder to record the selected program, when the television system has a plurality of different source devices, the method further involves connecting the video recorder to the desired source device and selecting the desired channel on that source device.

- 20 If the actively viewed source device and the device that is to provide the selected program are the same, the method further involves checking to determine whether the desired channel can be accessed from an alternative source device. If an alternative device is not found then a warning message (e.g. "Record failure: <RecordedDevice> in use") is displayed. If an alternative

source device is found, then the video recorder is connected to that alternative device.

5 The method may also involve stopping the video recorder recording at the end of the program. This can be done either by stopping the video recorder at the scheduled time or waiting until a stop label is broadcast at the end of the selected program. At the end of the selected program, the method preferably involves powering down the video recorder.

10 Preferably, until the recording is completed, attempts by the viewer to change channel on source device for the program that is being recorded cause a warning to be displayed, e.g.: "Recording in progress – OK to continue, STOP to cancel". If the viewer selects STOP, the recording is interrupted.

15 According to a still further aspect of the present invention, there is provided a controller for controlling a television system that includes a television tuner and a video recorder the controller preferably being integral with a television and comprising: means for storing details of a selected program, including a channel on which it is to be broadcast and a start time; means for checking the stored
20 program details to identify which channel number the selected program is to be broadcast on; means for determining whether a start label indicative of the start of the selected program is to be broadcast prior to the broadcast of the selected program; means for switching to the relevant channel and waiting until the start label is received, if it is determined that labels are to be broadcast; means for
25 causing the video recorder to record the desired program either on receipt of the start label or at the time stored in memory as measured on the real time clock

and means for determining whether or not a label indicative of the start of the selected program is to be broadcast preferably comprising a list of television channels that provide such start labels and means for searching the table for the channel on which the selected program is to be broadcast.

5

Preferably, means are provided for calculating the label using the announced start date and time of the selected program. The label may be a PDC or a VPS label, or some other real time broadcast data label that accurately signifies when the program is actually being broadcast.

10

Means may be provided for generating a prompt notifying the viewer of the imminent broadcast of the selected program. The means for generating may be operable to generate an interactive prompt. The interactive prompt may be operable to receive a response from a viewer indicative of whether the viewer
15 wants to record the program. Preferably, means are provided for causing the selected program to be recorded automatically on receipt of a positive response to the prompt.

20

The television system may include a plurality of different television signal source devices. Preferably, the controller has a means, for example a switch, for selectively connecting each of the television sources devices to the video recorder. This is advantageous as it means that the controller can automatically connect a selected one of the television sources to the recorder.

Preferably, the controller has means, for example a switch, for selectively connecting each of the television sources devices to a data decoder. Preferably, the data decoder is a teletext or P.31 decoder and/or a PDC/VPS decoder. This is advantageous because it means that whilst a viewer is recording a program on one channel received from one source, the controller can monitor data, such as start labels, that are transmitted by channels from other source devices.

Preferably, the controller has means, for example a switch, for selectively connecting each of the television sources devices to the television display. This is advantageous because it means that whilst a program on one channel received from one source is being recorded, the controller can simultaneously monitor data, such as start labels, that are transmitted on channels from another source device and the viewer can watch simultaneously, programs on channels from yet another source device. Each of the switches is controlled automatically by the controller so that the viewer does not have to set any of the external devices. This simplifies use of the television system.

Preferably, an emulator responsive to a single universal remote control is provided for controlling the television system, whereby signals sent to the emulator from the remote control are converted to signals that are recognisable by all components of the system. This is advantageous as it means that the user only has to interact with a single remote control.

Preferably, means are provided for generating an electronic program guide for displaying television program listings on the television screen. The guide may be presented in a grid format. In this way, the viewer can make program

selections merely by highlighting a selected box in the grid. Means are preferably provided in the guide for activating a record facility. For example, receipt of a pre-determined signal from a remote control, preferably, the universal remote control, may indicate that viewer wishes to record a selected program. Means are provided for automatically storing in memory the details of the program selected for recording. Using the guide in this way, means that a user merely has to select a program for recording, all other functionality, such as selecting the channel, checking whether a label designating the start of program exists, monitoring the time and starting and stopping the video recorder, is provided by the controller. Hence, from the user's perspective the overall system is greatly simplified.

Means may be provided for powering up pre-determined components a predetermined time prior to the stored start time. This is advantageous for unattended recording.

Preferably, means are provided for determining whether the video recorder is already being used and if so generating and displaying a warning message and prompt, e.g. "Recording is about to start – press OK to continue, STOP to cancel". If the viewer responds with STOP, the record process is aborted. If the viewer responds with OK, the means for causing the video recorder to record are activated and the recording begins.

Means may be provided for stopping the video recorder at the end of the program. This can be done either by stopping the video recorder at the scheduled time or waiting until the status or absence of a broadcast label

designates the end of the selected program. Means are also preferably provided for powering down the video recorder and/or any other device used at the end of the selected program.

5 Preferably, means are provided for causing a warning to be displayed when attempts are made to change channel on the source device for the program that is being recorded, e.g.: "Recording in progress – OK to continue, STOP to cancel".

10 According to yet another aspect of the present invention, there is provided a method of controlling a system that has a television (or PC TV or the like) and a plurality of external video signal source devices, the method comprising:
switching the television into a standby mode on receipt of a standby command signal and automatically switching each of the video signal source devices into
15 a standby mode on receipt of the television standby signal.

According to yet another aspect of the present invention, there is provided a controller for a system that has a television (or PC TV or the like) and a plurality of external video signal source devices, the controller comprising:
20 means for sending control signals to each of the external source devices and the television; means for switching the television into a standby mode on receipt of a standby command signal and means for automatically switching each of the video signal source devices into a standby mode on receipt of the television standby signal.

25

According to yet another aspect of the present invention, there is provided a computer program, preferably on a data carrier for controlling a system that has a television (or PC TV or the like) and a plurality of external video signal source devices, the program comprising means for automatically generating
5 signals for switching each of the video signal source devices into a standby mode on receipt of a signal that is operable to switch the television into a standby mode. An advantage of this system is that when the television is not in use, all the other external devices are automatically powered down.

10 According to yet another aspect of the present invention there is provided a controller for a television system that has a television or PC TV or the like and a plurality of external television signal source devices, the controller comprising means for sensing when each external device is being used and means for automatically switching any external device not being currently used into a
15 standby mode. An advantage of this is that power is not wasted.

According to yet another aspect of the present invention there is provided a method for controlling a television system that has a television or PC TV or the like and a plurality of external television signal source devices, the method
20 comprising means for sensing when each external device is being used and means for generating a signal for causing any external device not being currently used to be automatically switched into a standby mode. Preferably, the controller is provided in a television. In this way, by sensing when devices are not being used and then switching them into a standby mode, the overall power
25 consumption of the system is reduced. This is advantageous.

According to a still further aspect of the present invention, there is provided a controller for a television system, the controller comprising a plurality of inputs each operable to receive signals from one of a plurality of video signal source devices; means operable to selectively connect each of the plurality of inputs to a first television device, and means for selectively connecting one of the plurality of inputs to a second television device simultaneously with connection of another one of the inputs to the first device.

An advantage of this system is that a viewer can view a channel supplied by one source device whilst the decoder can simultaneously decode information from a signal from another source device. This means that the television system can be provided with up to date information even when it is being used to view television programs. A further advantage is that a viewer can view a channel supplied by one source device whilst the video recorder can simultaneously record a signal from another source device.

Preferably, the controller is provided in a television. Preferably the means for selectively connecting are a switch.

According to a still another aspect of the present invention, there is provided a method for controlling a television system, the method comprising receiving signals from a plurality of video signal source devices, providing a selected one of the signals to an on-screen display generator, and simultaneously providing another of the signals to a data decoder and/or a video recorder.

According to a yet another aspect of the present invention, there is provided a computer program for controlling a television system, the program comprising means for controlling the selective provision of one of the signals to an on-screen display generator, and means for controlling the selective provision of
5 another of the signals to a data decoder and/or a video recorder simultaneously with the signal provided to the on-screen display. An advantage of this system is that the video recorder can be readily connected to any one of the television source devices.

10 A system in which the various aspects of the invention are embodied will now be described by way of example only and with reference to the accompanying drawings, of which:

Figure 3 is a block diagram showing the connectivity between elements of a television system;

15 Figure 4 is a schematic diagram showing the IR connection between various components of the television system of Figure 3;

Figure 5 is a more detailed block diagram of the television system of Figure 4;

20 Figure 6 is a block diagram showing the connectivity between elements of television system containing a personal video recorder (PVR);

Figure 7 shows an example of an electronic program guide.

Figure 8 shows a PDC table, which lists whether PDC labels are broadcast by a given channel;

Figure 9 shows a channel source table containing information concerning from which device a channel is to be received and on what channel number;

5 Figure 10 shows a device control table identifying each device and by what method and physical input it is connected to the system, and

Figure 11 is a flow chart describing the control process for a user to select a TV program reminder and later be prompted by the system to view the program.

10 Figure 3 shows a television 10 that is connected via SCART links to three external devices, these devices being a first set top box STB1 for decoding satellite television signals, a second set top box STB2 for decoding cable television signals and a video recorder 11. Each device has an infra red eye window 12 for receiving commands from a universal remote control 14 that is
15 operable to generate and send IR control commands.

For ease of use, all the devices in the system are controlled using the single universal remote control 14. To this end, included in the television 10 is an emulator (not shown) that is arranged to receive command signals from the
20 universal remote and emulate the command signals of each of the television 10, the set top boxes STB1 and STB2 and the video recorder 11. Signals are sent from the emulator to the external devices using an IR "mouse tail" 16, i.e a wire-LED combination or optical lead that distributes IR signals to the IR eye windows 12 of the external devices, as shown in Figure 4. Of course, different
25 command interfaces (such as over the SCART or IEEE 1394 links) may be

employed to control external devices in addition to or instead of the IR mouse-tail 16.

Using the universal remote control 14, control commands intended for the set top boxes STB1, STB2 and the video recorder 11 are interpreted inside the television 10, converted to the appropriate format and retransmitted as IR signals to the selected device. Hence, irrespective of which device the viewer intends to control, the viewer points the universal remote 14 directly at the TV infra-red eye 12. All other signals are generated and transmitted to the appropriate device via the mouse-tail 16.

Figure 5 shows the internal layout of the television 10 of Figure 3. This has a programmable tuner 17 that is connected to an internal port AV0 and three external audio video input ports, AV1, AV2 and AV3. Connected to AV1 is the first set top box STB1; connected to AV2 is the second set top box STB2 and connected to AV3 is the video recorder 11.

Each input port AV0, AV1, AV2 and AV3 is connected to three programmable video switches S1, S2 and S3. The first switch S1 is a four way composite or RGB video switch that is selectively operable to connect each of the first and second set-top boxes, the programmable tuner 17 and an output 19 of the video recorder 11 to an on-screen display generator, which is in turn connected to a display device 20, such as a CRT. Depending on the nature of signal being switched, the on-screen display generator may contain a PAL/SECAM or other picture decoding function. The second switch S2 is also a four way switch and this is selectively operable to connect each of the first and second set-top boxes,

the programmable tuner 17 and the video recorder output 19 to a VBI data slicer that is connected to each of a teletext or P.31 decoder 24 and a PDC or VPS decoder 26. By sampling the signals at switch S2 it is possible to determine whether video is present and thereby sense whether an external source device is
5 in active mode. The third switch S3 is a three way switch and this is selectively operable to connect the first and second set-top boxes and the programmable tuner 17 to a "video-in" port 28 on the video recorder 11.

Provision of the switches S1 and S2 allows each of the programmable tuner 17,
10 the first and second set top boxes STB1, STB2 and the video recorder 11 to be selectively connected to the on screen display and the data decoder. This is advantageous as it means that a signal from one of the sources can be processed so that the viewer can watch the selected television program, whilst the decoder is simultaneously able to process information from a signal received from
15 another of the sources. Provision of the switch S3 allows each of the tuner 17 and the first and second set top boxes STB1, STB2 to be selectively connected to the video recorder so that a signal from one of the sources can be used to allow a television program to be viewed and/or processed by the decoder, whilst the video recorder is simultaneously recording a program on a channel received
20 from another of the sources.

In order to allow data exchange between the various components of the system, a data bus 30 is provided in the television 10. Connected to this are the on-screen display generator 18, the VBI data slicer 22, the teletext or P.31 decoder
25 24, the PDC/VPS decoder 26, a real time clock 32, a flash RAM 34, a DRAM, an IR transceiver 38 and a microprocessor (CPU) 40 that is additionally

connected to the programmable tuner 17. The CPU 40 has access to both
volatile DRAM 36 and non-volatile FLASH memory across the data bus 30 and
controls the on-screen display generator to write directly to the display device.
The on-screen display generator mixes or overlays CPU generated text and
5 graphics with baseband video, which may be scaled, cropped and moved within
the display area.

Hard coded in an embedded ROM within the television (not shown) is control
software, which shall be referred to herein as "firmware", that co-operates with
10 the CPU to control the overall system functionality. The CPU and firmware are
operable to control the position of the programmable switches S1, S2 and S3.
In addition, the CPU and firmware are operable to decode data that is
transmitted in the vertical blanking interval (VBI), including teletext and EPG
data, by using the baseband programmable video switch S2 to select input from
15 either the tuner 17 or from an external source device, such as the first or second
set-top boxes or the video recorder 11. Additionally the CPU and firmware
may sense whether an external source device is in active mode by sampling its
signal to determine whether video is present. The CPU and firmware, which is
operable also while the TV display is in standby, may be powered by a split
20 power supply that does not power up other TV sub-systems while the display is
not in use.

The CPU and firmware maintains in the DRAM memory the following status
information for each external device according to the last re-interpreted
25 command sent to it: powered state (PowerStatus), i.e. whether it is in Standby,
Active or (if a video recorder) Timer mode; last channel number

(DeviceChannelNumber) if set; operating mode (PlayStatus) of the video recorder: whether it is in Stop, Pause, Play or Record mode.

5 Whilst the control functionality of the system of Figures 3 and 5 is provided in the television, it will be appreciated that it could equally be provided in another device, for example, a personal video recorder (PVR). Figure 6 shows a PVR that is connected via SCART links to three external devices, these devices being a first set top box STB1 for decoding satellite television signals, a second set top box STB2 for decoding cable television signals and output to a television.
10 Each device has an infra red eye window 12 for receiving commands from a universal remote control 14 that is operable to generate and send IR control commands. The arrangement of internal components of the PVR necessary to implement the present invention is similar to that shown in Figure 5 and so will not be described in detail.

15

In order to facilitate use of the systems of Figure 3, 5 and 6, software is provided for generating an electronic program guide (EPG). In the case of the system of Figure 5, this software is maintained by the firmware in non-volatile memory 34. The EPG software is operable to create a grid into which
20 television program listings information can be added. An example of this is shown in Figure 7. The television listings include details of all programs available from each of the programmable tuner 17, the first set-top box and the second set-top box. When a television program is selected in the EPG for viewing, the first switch S1 is automatically switched to the desired source
25 device for the selected program.

Maintained in the flash RAM 34 is a PDCChannel table. For each channel that may be received by the television 10 or video recorder 11 or by the external source devices STB1 or STB2, this table lists an identifier and a flag to indicate whether it is supported by PDC broadcasts Figure 7 illustrates an excerpt from a PDCChannel table. In this, a logical true/false flag is used to indicate whether PDC is supported, with true indicating that it is supported and false indicating that it is not. From Figure 7 it can be seen that PDC is supported on BBC 1, Carlton, Channel 4, Channel 5 and Nickelodeon.

10 In order to up-date information in the PDC Channel table, the PDC Channel information is downloaded to the system, preferably by being broadcast as a P.31 or teletext signal in the VBI alongside other channel related information such as the TV listings data. This information can be received either via the TV tuner or via one of the source devices. Alternatively, the PDCChannel information does not have to be broadcast with the TV channels, but may be received by other means such as via a built-in pager broadcast receiver or via a built-in modem over the internet. PDCChannel information may be either broadcast continuously, or preferably, broadcast once or a small number of times per day along with other EPG data.

20 Stored in the non-volatile memory 34 is a ChannelSource table. Figure 8 is an example of an excerpt from such a table. This describes which channel is obtained from which source device together with the channel number (DeviceChannelNumber) the device needs to be tuned to, and whether it can be tuned to in order to receive EPG data.

25

The ChannelSource table is created by the CPU and modified each time a new external source device is installed or removed from the TV. When a new device is installed, the CPU+firmware scans through its available channel numbers to identify its Channel ID by decoding the teletext CNI labels. Later viewers may manually edit ChannelSource via an interactive display to the TV to edit identities of channels on which erroneous CNI data is broadcast or no identifying data was broadcast at all. Simultaneously, the CPU+firmware tests whether EPG data packets are received by the teletext/P.31 decoder. If these are received, the flag EPGHost is set to .true. in ChannelSource.

5
10

It will be understood that the ChannelSource table may have multiple entries per channel ID when more than one device receives the same channel. For example, the Figure 8 lists the "Carlton" channel ID twice because it can be received on both the TV's internal tuner (TV) and also on the internal tuner in the video-recorder 11.

15

In addition to the ChannelSource table, a DeviceControl table is stored in the non-volatile memory 34. An example of this is shown in Figure 9. This table contains user adjustable settings to identify which input a device is connected to and details of the type of control interface (e.g. IR or SCART AV-Link) to be used to control it, together with related parameters such as type of IR code to be used. This describes the overall connectivity of the system of Figure 5, where all external baseband video sources such as the video recorder and source devices (such as STB1 and STB2) are connected directly to the television.

20
25

As mentioned above, the television, controlled by the microprocessor (CPU) and real-time-clock (RTC), powers up the tuner periodically at certain times to receive EPG data. This data typically includes: PDCChannel table; TimeOfDay data packets for fine time adjustment of the RTC; Programme titles, start and stop times and channel description identities (Channel IDs). The CPU uses the
5 time of day information to update the real time clock in real time. The other data are written to non-volatile memory for later reference.

Using the EPG, a viewer may select programs he/she wants to be reminded to
10 view but does not actually want to record. In such cases a viewer highlights the program on the EPG display and selects a "Remind" control option. Just before the programme is due to start, a prompt is displayed on the on-screen display inviting the viewer to change channel to view the programme. The remind process of the invention will be described in more detail with reference
15 to Figure 11.

During TV viewing, the viewer selects a programme for Remind from among other programs listed or displayed by the EPG. Figure 7 shows an example of a screen display, where a viewer has already highlighted the program
20 "Hollywood Wives". By pressing a predetermined button on the universal remote 14, for example button "2", "Hollywood Wives" is selected for Reminding. The CPU then writes the Remind programme's details (including Channel ID and start and stop times) to non-volatile memory and sets the real-time clock to trigger an alarm for the start of the programme. The
25 CPU+firmware looks up the ChannelSource against Channel ID to identify which source device to power up for Reminding from (RemindedDevice) and

which device channel number (RemindedChannel) to set the RemindedDevice to. By default, the system chooses the first valid entry in the ChannelSource table for Channel ID. Once the correct device is identified, the CPU accesses the DeviceControl table to identify which TV video input the RemindedDevice is connected to and which control interface (e.g. IR) and related control parameters (e.g. IR code ID) to use. The PDCChannel table is also consulted to determine whether PDC is supported for the RemindedChannel.

If the CPU determines that PDC is supported by the reminded channel, then it calculates bit maps for one or more PDC labels for the Reminded program according to its broadcast announced time(s) and date(s). This is a known process and so will not be described here in detail. The CPU then monitors the status of Switch S1 to determine whether it is switched to the RemindedChannel source. If so, the viewer is watching from the same source and therefore the RemindedChannel cannot be selected if the source is external. If the source is internal the CPU checks whether the viewed channel is the same as Reminded Channel. If the CPU however cannot use the RemindedChannel source, it attempts then to use the non-PDC method. This will be described in more detail later.

20

If S1 was not switched to the RemindedChannel Source, the CPU looks up the ChannelSource, the value of DeviceChannelNumber for the RemindedDevice, and Channel ID. It then checks the selected video output to determine the selected device power status and transmits an IR sequence to control the selected device according to its power status, and sends a command to change to channel DeviceChannelNumber. The CPU then waits until the PDC labels

25

are received from the RemindedDevice and decoded by the PDC decoder, and displays a prompt on the television screen giving the viewer the opportunity to change channel: e.g. “<Remind programme title” is about to start – press OK to continue, STOP to cancel”. If the viewer selects STOP, the Remind process
5 is aborted. If, however, the viewer selects OK, a signal is sent to the CPU, which interprets the response and switches the first video switch S1 to the RemindedDevice. The selected program is then displayed to the viewer.

If the CPU determines that PDC is not supported, then it waits until the
10 program’s announced start time, as measured by the real time clock 32, and generates a prompt on the television display giving the viewer the opportunity to change channel: e.g. “<Remind programme title” is about to start – press OK to continue, STOP to cancel”. If the viewer selects STOP, the Remind process is aborted. If the viewer selects OK, the CPU looks up in the
15 ChannelSource table, the value of DeviceChannelNumber for the RemindedDevice and the Channel ID. The CPU then checks the selected video output to determine the selected device power status and transmits the IR sequence to control the selected device according to its power status, then sends a channel change to DeviceChannelNumber (i.e. a power up command to the
20 RemindedDevice followed a few seconds later by a GotoChannel command). The CPU then switches the first video switch S1 to the RemindedDevice and the selected program is displayed to the viewer.

The record process will now be described. This is slightly more involved than
25 the Remind process due to the need for the system to detect and respond to

situations when either the TV or a source device is in use and to power devices down after use.

5 During TV viewing, the viewer selects a program for automatic record from among other programs listed or displayed by the EPG. Using the example shown in Figure 7 again, by pressing a designated key on the universal remote control 14, for example, button "1", "Hollywood Wives" can be selected for recording. The CPU then writes the record program's details (including Channel ID, start and stop time) to non-volatile memory and sets the real time
10 clock 32 to trigger power-up of essential components necessary for the recording process just before the program is scheduled to be broadcast. These components include the CPU itself, the DRAM, the Flash RAM, the PDC decoder, the VBI data slicer, the IR transceiver and the second and third switches S2 and S3.

15

About one minute before the program is scheduled to start, the real time clock triggers power up of the essential TV components if the TV is not in active mode (display device powered up). The CPU+firmware then looks up the ChannelSource table to identify which device to power up for recording from
20 (RecordedDevice) and which device channel number (RecordedChannel) to set the RecordedDevice to. By default it chooses the first valid entry in the ChannelSource table for the Channel ID. The CPU then consults the DeviceControl table to identify which TV video input the RecordedDevice is connected to, and via which control interface (e.g. IR) and related control
25 parameters (e.g. IR code ID) to use.

31

If the TV was in active mode immediately prior to the expected broadcast time then the CPU+firmware checks the state of the first switch S1 or the second switch S2 to detect a video signal, in order to determine whether the viewer is using the video recorder 11. If so, a warning message and prompt (e.g.

5 “Recording is about to start – press OK to continue, STOP to cancel”) is displayed via the OSD. If the viewer responds with STOP, the record process is aborted. If the viewer responds with OK, the CPU 40 checks to determine from the state of S1 whether the actively viewed source device (if any) is the same as the RecordedDevice.

10

If the actively viewed source device and the recorded device match and the RecordedDevice is the built-in programmable TV tuner (AV0) then the CPU+firmware checks to determine whether RecordedChannel is listed against an alternative device in ChannelSource. If an alternative device is not found
15 then a warning message (e.g. “Record failure: <RecordedDevice> in use”) is displayed on the on-screen display 20 of the television 10. If an alternative device is found, then RecordedDevice takes on the identity of that alternative device. For example, the Channel Source table of Figure 9 shows a case for the channel “Carlton” where the video recorder can be set up to record via the video
20 recorder’s own tuner if the TV’s tuner is in use.

If the actively viewed source device and the recorded device match and the RecordedDevice is not the built-in TV tuner and the RecordedDevice is not already tuned to the RecordedChannel then a warning message (e.g.

25 “<RecordedDevice name> is in use – press OK to allow record, STOP to cancel”) is displayed via the OSD. If the viewer selects STOP, the process is

aborted. If the viewer selects OK, the CPU looks up in the ChannelSource table the value of the DeviceChannelNumber for the RecordedDevice and the Channel ID. The CPU then transmits a power up command to the RecordedDevice and the video recorder 11, followed a few seconds later by a
5 GotoChannel command to the RecordedDevice to set it to DeviceChannelNumber. The CPU then causes the third video switch S3 to switch to the input to which the RecordedDevice is connected.

In addition to the above, the CPU looks up the PDCChannel table to determine
10 whether PDC is supported for the RecordedChannel. If PDC is supported, the CPU calculates the bit maps for one or more PDC labels for the recorded program according to its broadcast announced time(s) and date(s) and waits until these are received and decoded by the PDC decoder from the RecordedDevice. The CPU then prepares the video recorder to record and
15 initiates recording according to whether the PDC prepare to record flag is set and the type of video recorder device. Finally, the CPU stops the video recorder recording at the end of the programme according to how and when the broadcast PDC labels require and powers down the RecordedDevice and video recorder.

20

If PDC is not supported, the CPU waits until approximately 10s before the programme's announced start time, as measured by the real time clock, and prepares the video recorder 11 to record depending on the type of video recorder device (e.g by setting it into record-pause and then record-play at the
25 start of recording when video recorder is a video-cassette-recorder). At the end

of the broadcast announced duration, the CPU stops the video recorder recording and powers down the RecordedDevice and video recorder.

5 Until the recording is completed, attempts by the viewer to change channel on RecordedDevice cause a warning, e.g.: “Recording in progress – OK to continue, STOP to cancel”) to be displayed on the OSD. If the viewer selects STOP, the recording is interrupted.

10 In the embodiments described above, the video recorder and other source devices are controlled via the CPU. Each time a viewer changes channel, whether via use of an EPG or via a manual channel change command, the viewer’s IR command sent from the universal remote 14 is intercepted, translated and re-transmitted down the mouse tail using the IR code sequence specific to the external device under control.

15

In order to save on power consumption, when a command is sent from the universal remote control 14 to switch the television 10 into a standby mode, power off signals are automatically generated and sent to each of the external devices ie the first and second set-top boxes and the video recorder 11. This means that when the television is not being used all the peripheral devices are switched into a low power mode. This is advantageous.

20

The CPU+firmware maintains in non-volatile memory the last channel viewed immediately before the TV was powered down into standby. Upon TV power up into active mode, the CPU+firmware automatically sets the first switch S1 to

25

the source device used to receive the last channel. The CPU then powers up the device if it is external (e.g. not the TV tuner) and sets it to the last channel.

When a viewer selects a channel that requires an external device to be powered up, then the CPU+firmware powers up that device. In order to reduce channel change delays, the same device is typically not powered off when a viewer
5 changes to a channel that does not originate from the external device, although, this is possible.

In addition to solving problems associated with system complexity and
10 excessive power consumption, the systems of Figures 3, 5 and 6 can be used to improve the supply of EPG data to the viewer.

As previously mentioned the data for use in constructing the EPG is typically downloaded via the VBI to the CPU. At present, this is done via signals that
15 can be received using the programmable tuner in the television. This involves sending the data at predetermined times on a pre-determined channel and causing the tuner to switch to that channel at the appropriate time in order to receive the data and sent it to an appropriate decoder. This, however, has the disadvantage that if the programmable tuner 17 is being used, the EPG data
20 cannot be decoded.

In order to alleviate the problem of how to up-date EPG data, rather than transmitting the data to a single television source device, the data is transmitted to a plurality of different source devices. Hence, in the present case, the data
25 may be downloaded in the VBI of a host channel that is transmitted to the programmable tuner and additionally a host channel that is transmitted to the

35

first set top box STB1. Stored in the DRAM are the time and channel details of the download for each source device. Using the stored information, the CPU can then control the programmable switches to cause an unused source device to be connected to the decoder so that even if the television is being viewed, it is still possible to receive and decode EPG data.

As an example of how EPG data may be processed, suppose that a data download is scheduled for 10pm each evening on channel 3, i.e. Carlton, via the programmable tuner 17 and channel 79, i.e. Sky News, via the second set top box STB2. A few seconds before the expected download, the CPU checks the ChannelSource table to determine the sources on which the information is to be provided. This is done by checking the EPGHost flags. If the television is not being used at the time, the CPU causes either one of the programmable tuner 17 or the second set top box STB2 to be set to the correct channel. Once the channel is set, the CPU then causes the second switch S2 to connect the selected one of the programmable tuner 17 or the second set top box STB2 to the VBI data slicer 22, so that the incoming EPG data can be received and decoded.

If the television is being used, the CPU checks the channel source table to determine the status of the EPG host flag of the viewed channel. If the viewed channel is a host channel, say, Carlton, the CPU causes the second switch S2 to switch to connect the programmable tuner 17 to the VBI data slicer 22. In this way, the EPG data transmitted on channel 3 can be processed.

If at the time of the download, a viewer happens to be watching BBC1, which is not a host channel (see the ChannelSource table), the CPU searches for another

source device that has a host channel. In this example, channel 79 of the second set top box STB2 is a host channel and so the CPU sets the second set top box STB2 to channel 79 and causes the second switch S2 to connect the second set top box STB2 to the VBI data slicer 22. Likewise, if a viewer happens to be
5 using the second set top box STB2 at the download time, the CPU would set the programmable tuner 17 to the host channel, i.e. 3, and cause the second switch S2 to connect the programmable tuner to the data decoder. In this way, downloaded EPG data can always be received and decoded to provide up to date EPG information, regardless of whether or not the television is being used.

10

The processes for selecting a device from which to receive EPG data may be disabled by a number of higher priority processes that may require alternative settings for S2. The higher priority processes may include the following:

1. the CPU+firmware is in the Remind or Record feature processes
15 respectively for a PDC enabled channel;
2. the TV is in teletext display mode;
3. the user has disabled in the alternate hosts feature in a set-up screen.

20 The television system and methods described herein provide a simple way for users to record or be reminded of television programs that are received from more than one television signal source device. This is done by providing software for determining from a label memory whether a label, such as a VPS or PDC label, indicative of the real start time of a selected program is to be
25 transmitted. If it is determined that labels are to be transmitted, the controller is primed to receive those labels at a pre-determined time. In response to receipt of the label, a prompt reminding the viewer of the transmission of the selected

television program is generated. In the event that it is determined that VPS or PDC or the like is not supported by the channel on which the selected program is to be transmitted, a real time clock is monitored and a short time before the scheduled time for transmission, a prompt reminding the viewer of the television program is generated. The functionality of this system considerably reduces the complexity of trying to record television programs, which is attractive to consumers. The television system and methods described herein are also advantageously arranged to reduce power consumption of unused external video source devices. Furthermore, the television system enables viewers to receive up to date information, whilst viewing the television. Again this provides advantages for the viewer.

A skilled person will appreciate that variations of the disclosed arrangements are possible without departing from the invention. Accordingly, the description of the specific embodiments is made by way of example and not for the purposes of limitation. It will be clear to the skilled person that minor modifications can be made without significant changes to the operation described above.

CLAIMS

1. A controller for a television system comprising:
 - 5 a memory for storing information relating to a selected television program, including a channel on which it is to be transmitted and a scheduled start time;
 - a label memory for storing information on a plurality of channels on which are transmitted labels that are indicative of real start times of television programs;
 - 10 means for determining from the label memory and using the channel information whether a label indicative of the real start time of the selected program is to be transmitted;
 - means for allowing receipt of the label, in the event it is determined that a label is to be transmitted, and
 - 15 enabling means for enabling a control function in response to receipt of the label or, in the event that a label is not to be transmitted, at substantially the scheduled start time stored in memory, as measured by a real time clock.
2. A controller as claimed in claim 1, wherein the enabling means are
20 operable to generate a prompt to remind the viewer that the selected program is to be shown.
3. A controller as claimed in claim 1, wherein the enabling means are operable to cause the selected television program to be recorded.

4. A controller as claimed in claim 1, wherein the details of the selected program include a stop time.
- 5 5. A controller as claimed in any one of the preceding claims, wherein the label memory includes a table of television channels that provide start labels.
6. A controller as claimed in claim 5, wherein the means for determining are
10 operable to search the table for the channel on which the selected program is to be broadcast.
7. A controller as claimed in any one of the preceding claims, wherein
15 means are provided for calculating the label using the start time of the selected program.
8. A controller as claimed in any one of the preceding claims, wherein the
20 label is a PDC or a VPS label or any other real time data label that is indicative of when a television program is to be transmitted.
9. A controller as claimed in any one of the preceding claims when directly or indirectly dependent on claim 2, wherein the enabling means are operable to generate an interactive prompt.

10. A controller as claimed in claim 9, wherein means are provided for receiving a response from a viewer indicative of whether the viewer wants to view the program.
- 5 11. A controller as claimed in claim 10, wherein means are provided for automatically causing the selected program to be displayed on receipt of a positive response to the prompt.
- 10 12. A controller as claimed in any one of the preceding claims, wherein means are provided for selectively connecting one of a plurality of different television sources devices to an on screen display generator.
- 15 13. A controller as claimed in any one of the preceding claims further comprising means, for example a switch, for selectively connecting one of a plurality of television sources devices to a data decoder.
- 20 14. A controller as claimed in any one of the preceding claims further comprising means, for example a switch, for selectively connecting one of a plurality of television sources devices to a video recorder.
15. A controller as claimed in any one of the preceding claims, wherein means are provided for generating an electronic program guide for displaying television program listings.

16. A controller as claimed in claim 15, wherein means are provided in the guide for activating a remind facility.
17. A controller as claimed in claim 16, wherein selection of the remind facility for a selected program causes the information relating to the selected program to be stored in the memory, including the scheduled start time, and primes the enabling means.
18. A television or PCTV or a set top box or a video recorder that includes a controller as claimed in any one of the preceding claims.
19. A method for controlling a television system comprising:
- storing in a memory information relating to a selected television program, including a channel on which it is to be transmitted and a scheduled start time;
 - storing in a label memory information on a plurality of channels on which are transmitted labels that are indicative of real start times of television programs;
 - determining from the label memory whether a label indicative of the real start time of the selected program is to be transmitted, using the channel information;
 - allowing receipt of the label, in the event it is determined that a label is to be transmitted, and

enabling a control function in response to receipt of the label or, in the event that a label is not to be transmitted, at substantially the scheduled start time stored in memory, as measured by a real time clock.

- 5 20. A method as claimed in claim 19, wherein the step of enabling involves generating a prompt to remind the viewer that the selected program is to be shown.
- 10 21. A method as claimed in claim 19, wherein the step of enabling comprises causing the selected television program to be recorded.
22. A method as claimed in claim 19, wherein the information relating to the selected program includes a scheduled stop time.
- 15 23. A method as claimed in any one of claims 19 to 22, wherein the label memory includes a table of television channels that provide start labels.
- 20 24. A method as claimed in claim 23, wherein the step of determining comprises searching the table for the channel on which the selected program is to be broadcast.
25. A method as claimed in any one of claims 19 to 24, further involving calculating the label using the scheduled start time of the selected program.

26. A method as claimed in any one of claims 19 to 25, wherein the label is a PDC or a VPS label or any other real time data label that is indicative of when a television program is to be transmitted.
- 5
27. A method as claimed in any one of the preceding claims when directly or indirectly dependent on claim, wherein the step of enabling involves generating an interactive prompt.
- 10
28. A method as claimed in claim 27, further comprising receiving a response from a viewer indicative of whether the viewer wants to view the program.
- 15
29. A method as claimed in claim 28, comprising causing the selected program to be displayed on receipt of a positive response to the prompt.
30. A method as claimed in any one of claims 19 to 29, comprising connecting one of a plurality of different television source devices to an on screen display generator.
- 20
31. A method as claimed in any one of claims 19 to 30 further comprising selectively connecting one of a plurality of television sources devices to a data decoder.

32. A method as claimed in any one of claims 19 to 32 further comprising selectively connecting one of a plurality of television sources devices to a video recorder.
- 5 33. A method as claimed in any one of claims 19 to 32, comprising generating an electronic program guide for displaying television program listings.
- 10 34. A method as claimed in claim 33, comprising activating a remind facility using the guide.
- 15 35. A method as claimed in claim 34, wherein selection of the remind facility for a selected program causes the information relating to the selected program to be stored in the memory, including the scheduled start time, and primes the enabling means to get ready to carry out the control function.
- 20 36. A computer program, preferably on a data carrier or some other computer readable medium, the computer program comprising instructions for:
storing in a memory information relating to a selected television program, including a channel on which it is to be transmitted and a scheduled start time;
storing in a label memory information on channels on which are transmitted labels that are indicative of a real start of a television program;

determining from the label memory whether a label indicative of the real start time of the selected program is to be transmitted;

generating control signals to enable receipt of the label, in the event it is determined that a label is to be broadcast, and

5 enabling a control function relating to the selected television program in response to receipt of the label or, in the event that a label is not to be transmitted, at substantially the scheduled start time stored in memory, as measured by a real time clock.

10 37. A computer program as claimed in claim 36, wherein the instructions for enabling a control function are operable to generate a prompt for display on a screen to remind the viewer that the selected program is to be shown.

15 38. A computer program as claimed in claim 36, wherein the instructions for enabling are operable to generate control signals to cause the selected television program to be recorded.

20 39. A computer program as claimed in any one of claims 36 to 38, wherein the label memory includes a table of television channels that provide start labels and the instructions for determining are operable to search the table for the channel on which the selected program is to be broadcast.

25 40. A computer program as claimed in any one of claims 36 to 39, comprising instructions for calculating the label for the selected television program using the start time.

41. A computer program as claimed in any one of claims 36 to 40, wherein the label is a PDC or VPS label.
- 5 42. A television or PCTV or a set top box or a video recorder that includes a computer program as claimed in any one of claims 36 to 41.
43. A controller for a television system that has a television (or PC TV or the like) and a plurality of external devices connected to the television, the
10 controller comprising means for automatically putting each of the external devices in a standby mode when the television is put into a standby mode.
44. A controller as claimed in claim 43 comprising means for receiving a signal that indicates that the television is in a standby mode.
- 15 45. A controller as claimed in claim 43 or claim 44, further comprising means for sending control signals to each of the external devices.
46. A controller as claimed in claim 45, wherein the means for sending
20 control signals comprise a wireless link.
47. A controller as claimed in claim 46, wherein the wireless link is an IR wireless link.

48. A controller as claimed in any one of claims 43 to 47, wherein the external devices comprise a video recorder, in particular a personal video recorder and/or a set top box.
- 5 49. A television or PCTV or a set top box or a video recorder or any other television apparatus that includes a controller as claimed in any one of claims 43 to 48.
- 10 50. A method for controlling a television system that has a television (or PC TV or the like) and a plurality of external video signal source devices, the method comprising automatically putting each of the external video signal source devices in a standby mode when the television is put into a standby mode.
- 15 51. A computer program, preferably on a data carrier or some other computer readable medium, for controlling a television system that has a television (or PC TV or the like) and a plurality of external video signal source devices, the computer program comprising instructions for generating control signals for automatically causing each of the external video signal source devices to be put in a standby mode when the television is put in a standby mode.
- 20 52. A television or PCTV or a set top box or a video recorder that includes a computer program as claimed in claim 51.

53. A controller for a television system that has a television or PC TV or the like and a plurality of external television signal source devices, the controller comprising means for sensing when each external device is being used and means for automatically putting any external device not being currently used into a standby mode.
54. A television or PCTV or a set top box or a video recorder that includes a controller as claimed in claim 53.
55. A method of controlling a television system that has a television or PC TV or the like and a plurality of external television devices, the method comprising means sensing when each external device is being used and automatically putting any external device not being currently used into a standby mode.
56. A computer program for a television system that has a television or PC TV or the like and a plurality of external television signal source devices, the computer program comprising means interpreting a signal that indicates that at least one of the external devices is not being used and means for automatically causing control signal to be generated to put any external device not being currently used into a standby mode.
57. A television or PCTV or a set top box or a video recorder that includes a computer program as claimed in claim 56.

58. A controller for a television system, the controller comprising:
a plurality of inputs each operable to receive signals from one of a
plurality of video signal source devices,

5 means operable to selectively connect each of the plurality of inputs to a
first television device, and

means for selectively connecting one of the plurality of inputs to a
second television device simultaneously with connection of another one of the
inputs to the first device.

10

59. A controller as claimed in claim 58, wherein the first television device is
an on-screen display.

60. A controller as claimed in claim 59, wherein the second television device
15 is a decoder or a video recorder.

61. A controller as claimed in any one of claims 58 to 60, wherein the means
operable to selectively connect each of the plurality of inputs to a first
television device comprise a switch.

20

62. A controller as claimed in any one of claims 58 to 61, wherein the means
for selectively connecting another one of the plurality of inputs to a
second television device comprise a switch.

63. A controller as claimed in any one of claims 58 to 62, wherein the video signal source devices comprise a cable set top box and/or a satellite set top box and/or a video recorder.
- 5 64. A television or PCTV or a set top box or a video recorder that includes a controller as claimed in any one of claims 58 to 63.

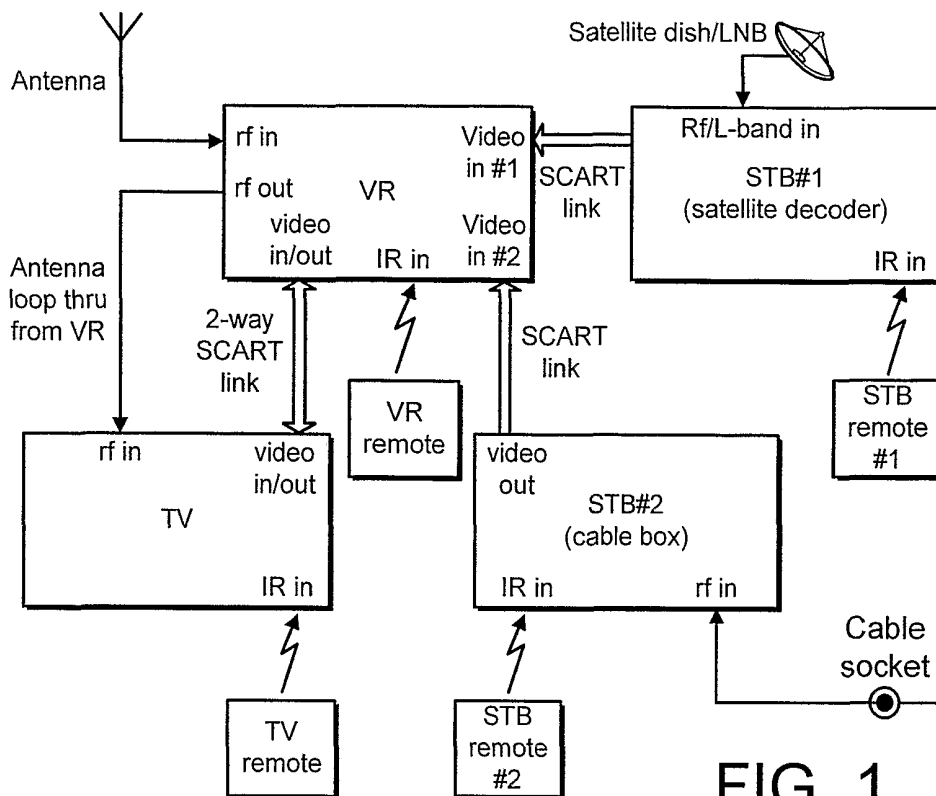

FIG. 1

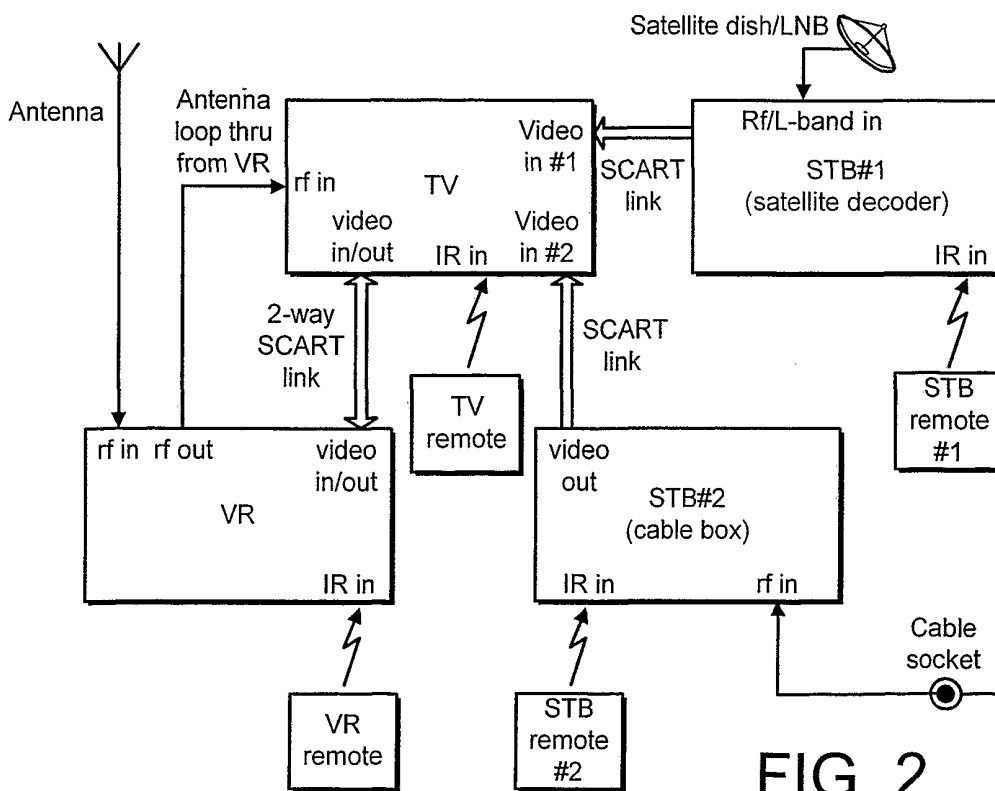

FIG. 2

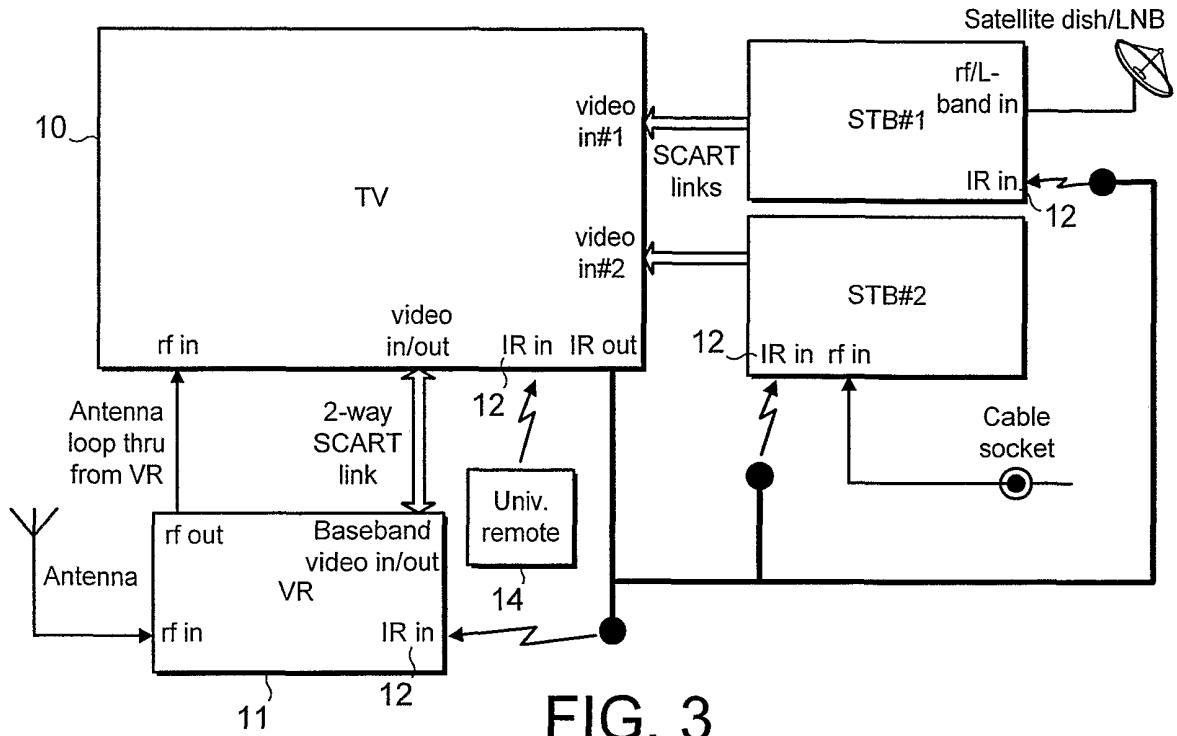

FIG. 3

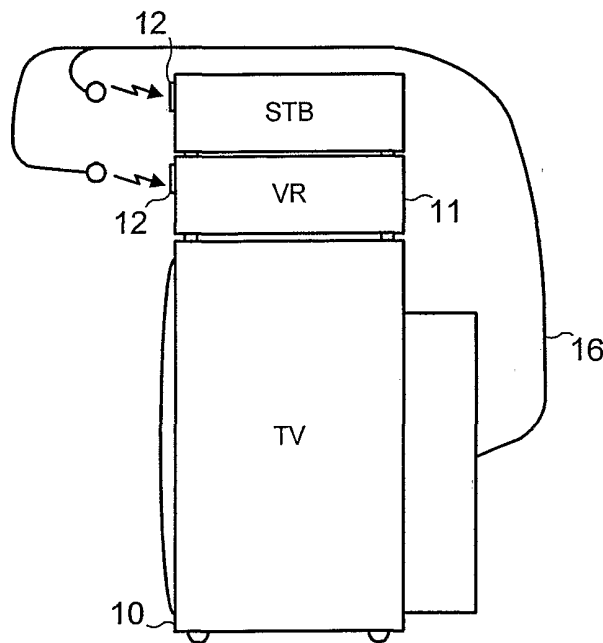

FIG. 4

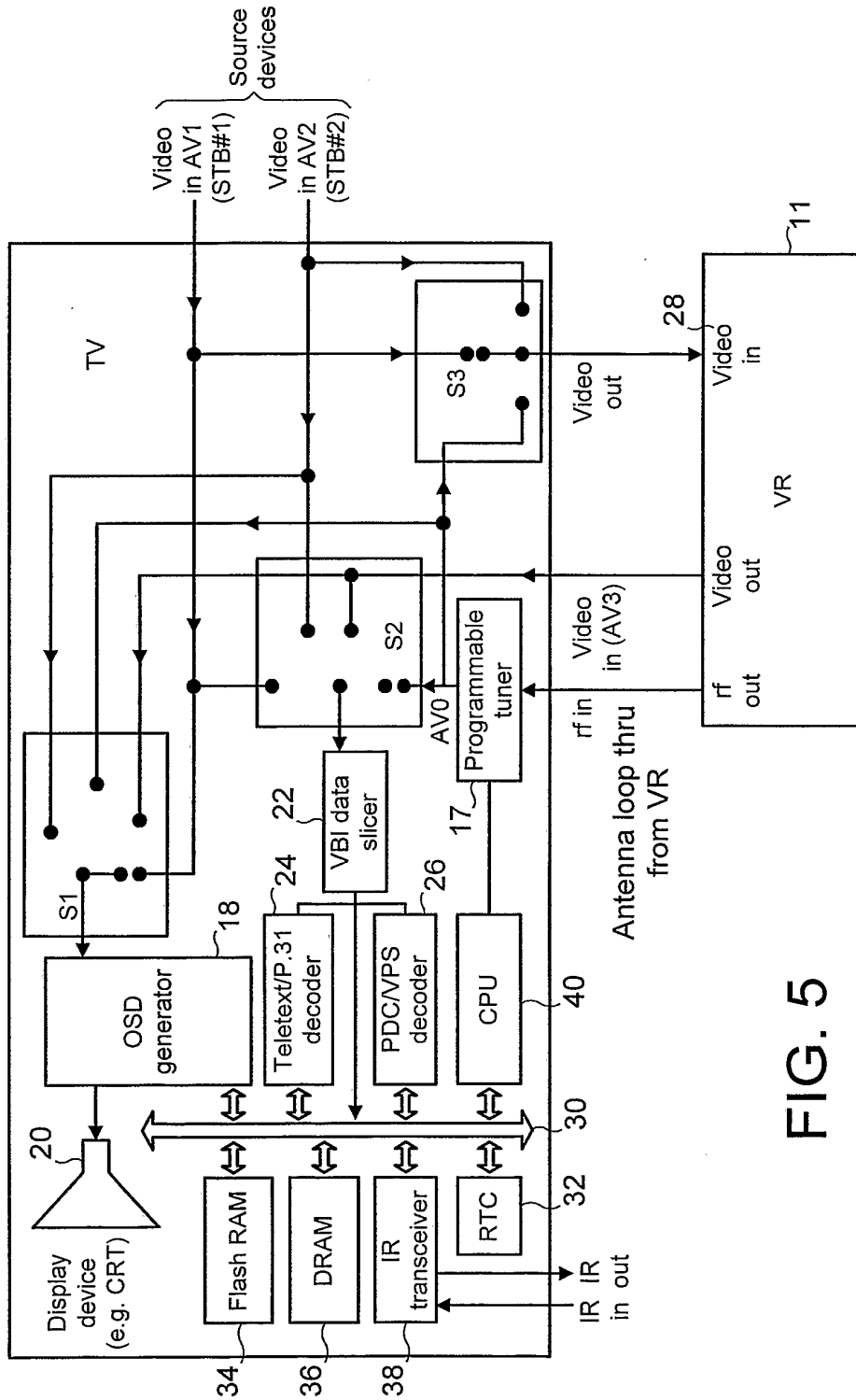

FIG. 5

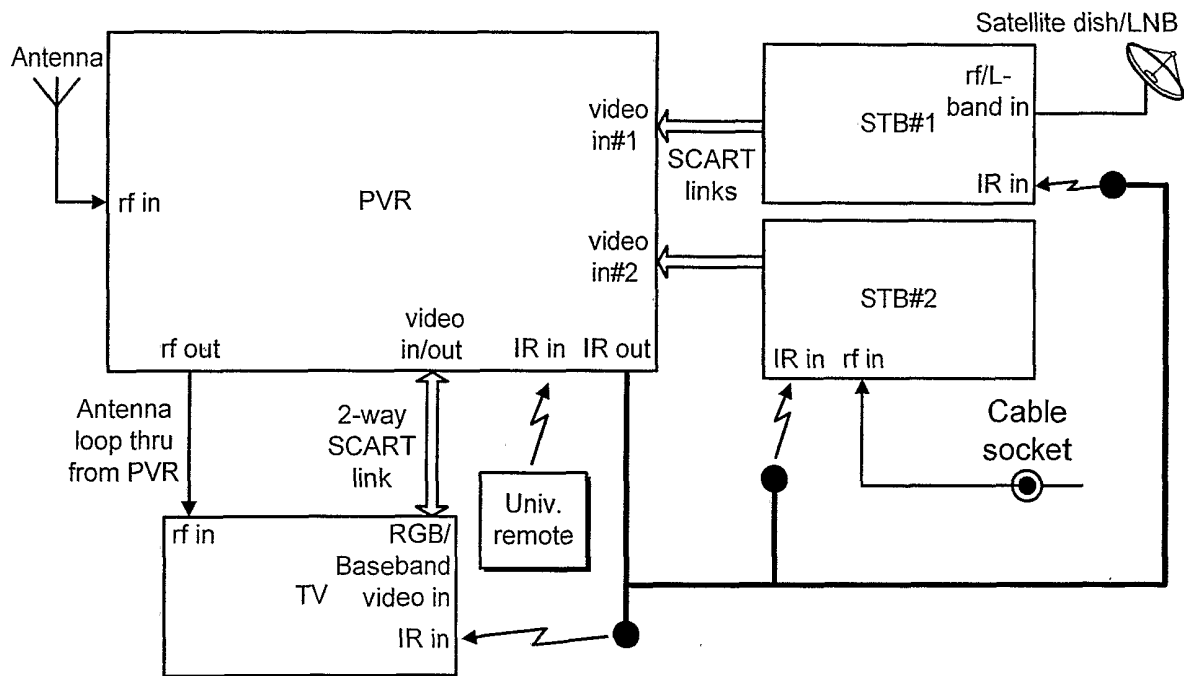

FIG. 6

1: RECORD	2: REMIND	3: OTHER	4: OTHER
<p>Hollywood Wives: In this episode Adam discovers that Eve has been trying to buy...</p>			
	9pm	9.30pm	10pm
BBC1	Love in Vegas		Documentary
BBC2	News	Movie: Sound of Music	
Carlton	Weather	Ground Force	
Channel4	Moving House		The Bionic...
Channel5	Wogan	Hollywood Wives	
SkyOne	News	Simpsons - Double bill	

FIG. 7

PDCChannel Table

CHANNEL ID	PDC
BBC1	.true.
BBC2	.false.
Carlton	.true.
Channel 4	.true.
Channel 5	.true.
SkyOne	.false.
SkyNews	.false.
Nickelodeon	.true.

FIG. 8

Channel Source table

CHANNEL ID	DEVICE NAME	DEVICE CH NUMBER	EPG HOST
BBC1	TV	1	.false.
BBC2	TV	2	.false.
Carlton	TV	3	.true.
Carlton	VR	9	.true.
Channel 4	STB#1	104	.false.
Channel 5	STB#1	105	.false.
SkyOne	STB#2	63	.false.
SkyNews	STB#2	79	.true.
Nickelodeon	STB#2	15	.false.

FIG. 9

Device Control table

DEVICE NAME	INPUT	METHOD	CONTROL PARAMETERS
TV	AV0	12C	ZXY
STB#1	AV1	IR	ABC31
STB#2	AV2	AV Link	QX
VR	AV3	IR	AB32

FIG. 10

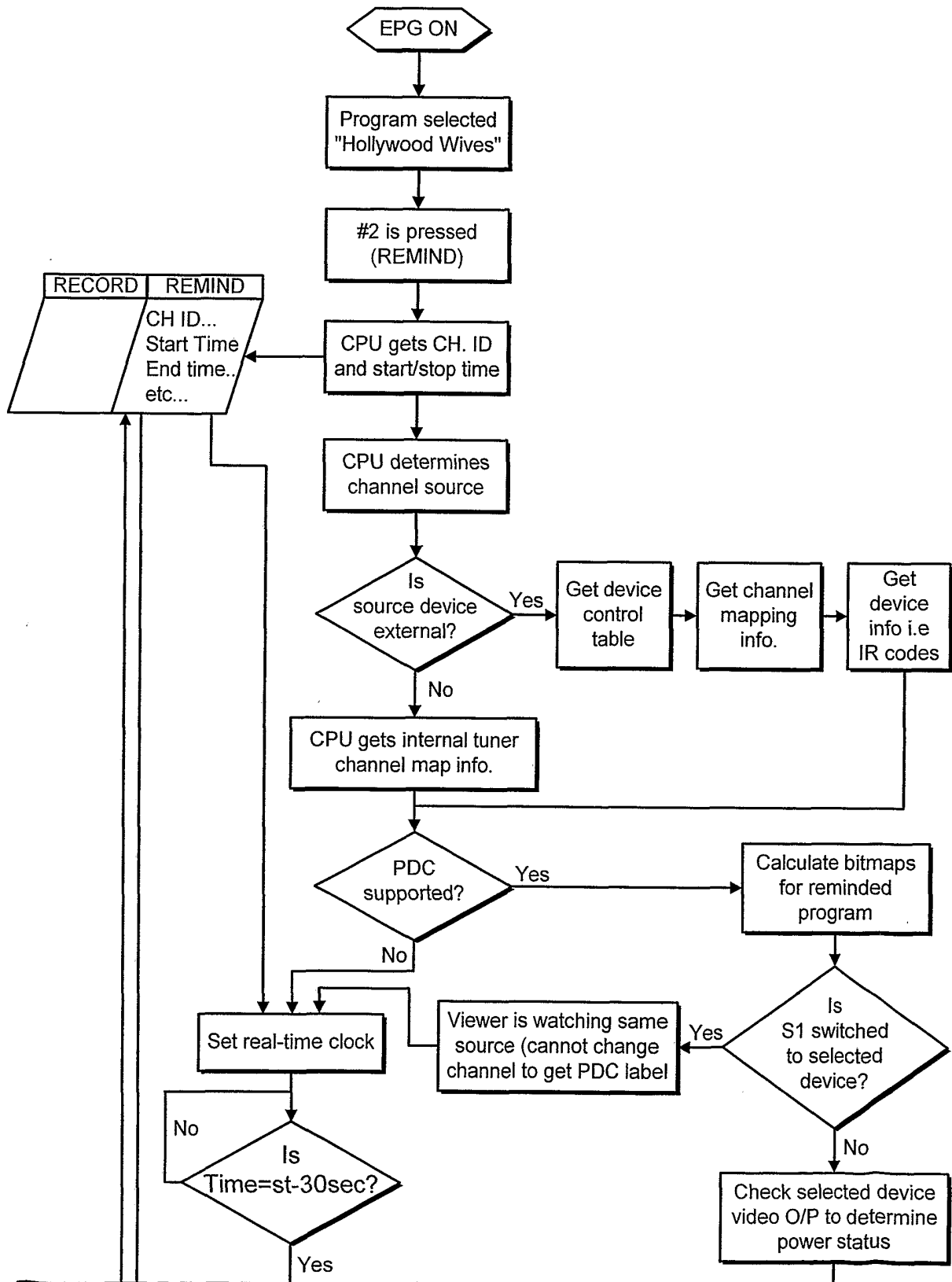

FIG. 11

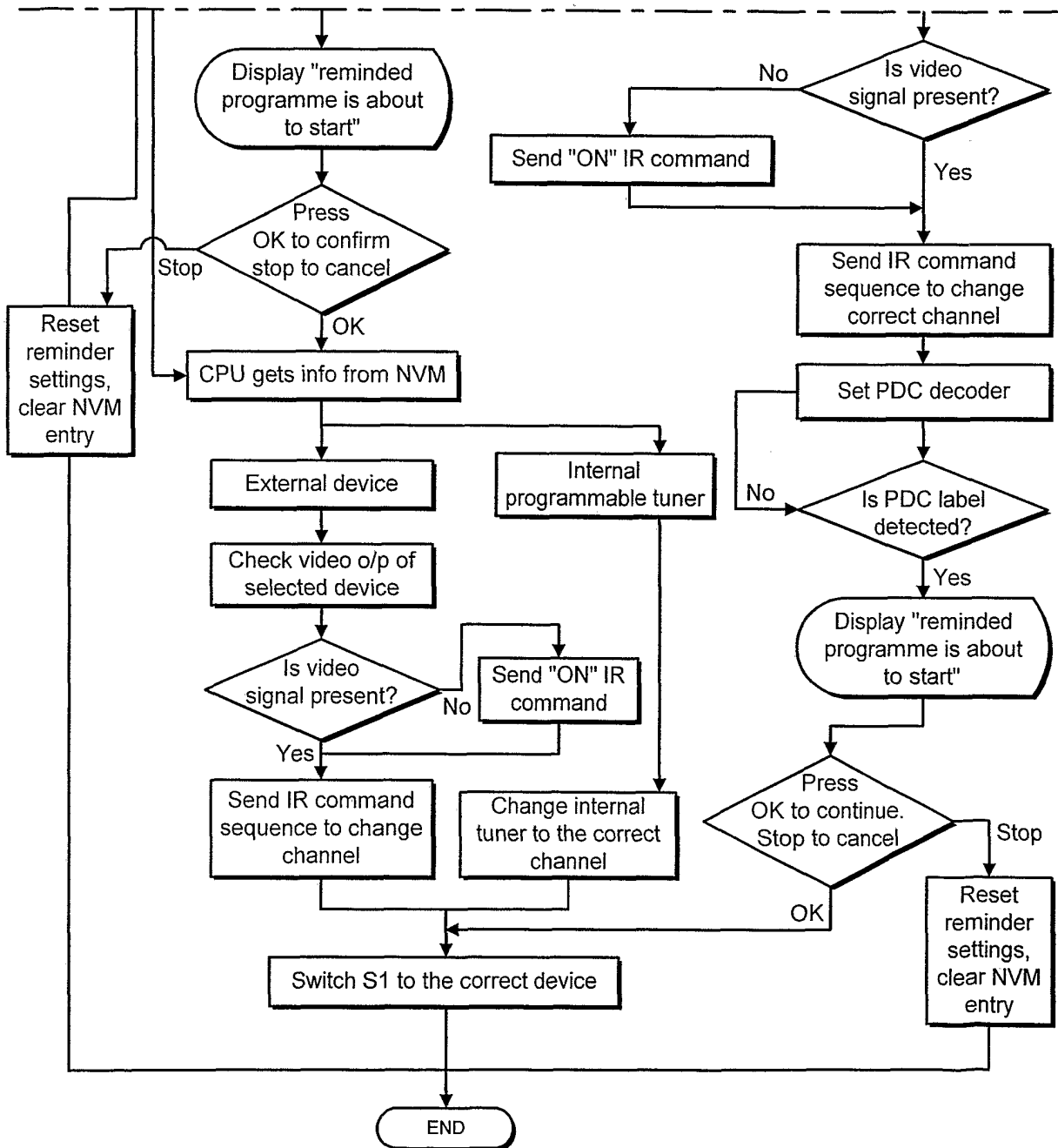

FIG. 11cont'd