



(51) International Patent Classification:

B65D 83/08 (2006.01) B65D 77/38 (2006.01)
B65D 5/54 (2006.01) B65D 5/49 (2006.01)

(21) International Application Number:

PCT/MY2019/050087

(22) International Filing Date:

12 November 2019 (12.11.2019)

(25) Filing Language:

English

(26) Publication Language:

English

(30) Priority Data:

PI 2018704235 12 November 2018 (12.11.2018) MY

(72) Inventor; and

(71) Applicant: **CHOU, Miew Fatt** [MY/MY]; B-7-3 Pangsa-
puri Boulevard, Jalan Kenanga, Kampung Sungai Ara,
Petaling Jaya, 47400 (MY).

(74) Agent: **LAW, Yew Foo**; LAW Partnership, Level 12, Tow-
er 8, Avenue 5, The Horizon Phase 2, Bangsar South, No 8,
Jalan Kerinchi, Kuala Lumpur, 59200 (MY).

(81) Designated States (unless otherwise indicated, for every
kind of national protection available): AE, AG, AL, AM,
AO, AT, AU, AZ, BA, BB, BG, BH, BN, BR, BW, BY, BZ,
CA, CH, CL, CN, CO, CR, CU, CZ, DE, DJ, DK, DM, DO,
DZ, EC, EE, EG, ES, FI, GB, GD, GE, GH, GM, GT, HN,
HR, HU, ID, IL, IN, IR, IS, JO, JP, KE, KG, KH, KN, KP,
KR, KW, KZ, LA, LC, LK, LR, LS, LU, LY, MA, MD, ME,
MG, MK, MN, MW, MX, MY, MZ, NA, NG, NI, NO, NZ,
OM, PA, PE, PG, PH, PL, PT, QA, RO, RS, RU, RW, SA,
SC, SD, SE, SG, SK, SL, SM, ST, SV, SY, TH, TJ, TM, TN,
TR, TT, TZ, UA, UG, US, UZ, VC, VN, ZA, ZM, ZW.

(84) Designated States (unless otherwise indicated, for every
kind of regional protection available): ARIPO (BW, GH,
GM, KE, LR, LS, MW, MZ, NA, RW, SD, SL, ST, SZ, TZ,
UG, ZM, ZW), Eurasian (AM, AZ, BY, KG, KZ, RU, TJ,
TM), European (AL, AT, BE, BG, CH, CY, CZ, DE, DK,
EE, ES, FI, FR, GB, GR, HR, HU, IE, IS, IT, LT, LU, LV,

(54) Title: DISPENSER FOR DISPENSING GLOVES CUFF-FIRST

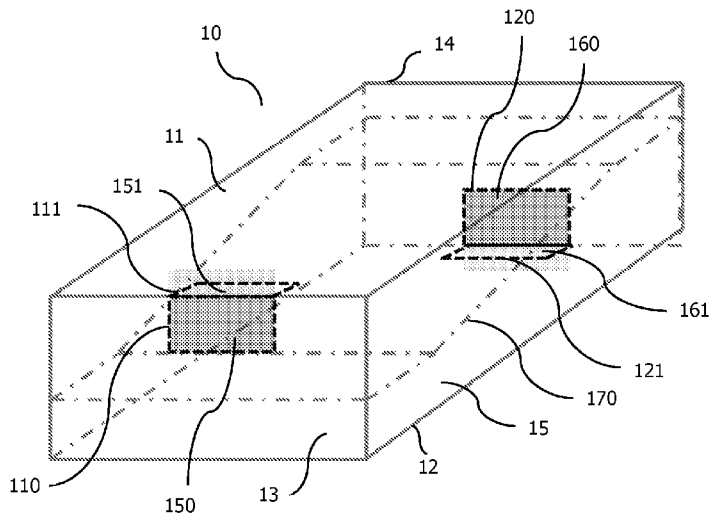

Figure 1A

(57) Abstract: A dispenser for disposable gloves comprising a box (10) having a plurality of faces (11, 12, 13, 14), two stacks of unfolded gloves (60, 61) disposed in the box and a static internal separator (170, 270) positioned between each stack of gloves. The box has 5 perforated lines (110, 120; 211, 221) on at least two opposing faces. The perforated lines are tearable providing a respective dispensing aperture (151, 161; 251, 261) on each opposing face. Each stack of gloves is orientated in the box so that the cuff of the gloves is positioned adjacent to the dispensing aperture for dispensing cuff-first through said dispensing aperture.



MC, MK, MT, NL, NO, PL, PT, RO, RS, SE, SI, SK, SM,
TR), OAPI (BF, BJ, CF, CG, CI, CM, GA, GN, GQ, GW,
KM, ML, MR, NE, SN, TD, TG).

Published:

- *with international search report (Art. 21(3))*
- *before the expiration of the time limit for amending the claims and to be republished in the event of receipt of amendments (Rule 48.2(h))*
- *in black and white; the international application as filed contained color or greyscale and is available for download from PATENTSCOPE*

DISPENSER FOR DISPENSING GLOVES CUFF-FIRST

This invention relates to a dispenser adapted to hold and dispense a plurality of gloves. More particularly, the invention relates to a dispenser adapted to hold and dispense a plurality of gloves cuff-first.

5

DESCRIPTION OF THE PRIOR ART

Most gloves used in hospitals and clinics are examination gloves, and these are used in large numbers. Such gloves are supplied not in individual sterile packages, but in relatively inexpensive cardboard dispensing boxes. The dispenser typically consists of quantities of gloves that are contained in a corrugated box with a perforated region.
10 When the perforated region is removed, an opening is provided through which gloves are withdrawn by a user.

In a dispenser which dispenses gloves that are in vertical position, one or more portions of gloves often protrude through the opening when the dispensing box is nearly or completely filled with a plurality of gloves. When the dispensing box is completely or
15 nearly full, it can be difficult for a user to grasp one glove without causing inadvertent dispensing of additional gloves.

Once the first 10 to 20 percent of the gloves are dispensed, a space between the opening and the plurality of gloves is created. This space requires a user to place a portion of his/her hand into the opening to grasp a glove. As this space increases when more of the
20 gloves are dispensed from the dispenser, the gloves have a tendency to collapse from their dispensing position and to clump together at the bottom of the dispenser. This results in a user having to place his/her hand deep into the dispenser to dispense a single glove.

In a dispenser which dispenses gloves that are in horizontal position, the same problems
25 occur when the dispenser is nearly or completely full of gloves. Again, once the first 10-20 percent of gloves are dispensed, the user is required to place his/her hand into the opening of the dispenser to retrieve a glove. While clumping may not occur, the continued admittance of user hands into a dispenser opening may result in contamination of one or more gloves, or the entire internal compartment of the dispenser and most or
30 all of the plurality of gloves.

One way of controlling contamination on such examination gloves is by packaging the gloves with over-folded cuffs within a box having a dispensing aperture. Since the gloves are folded, there is less surface area to contaminate.

US 2011/0062179 relates to the dispensing of gloves from a dispenser, the dispenser comprising a container and a plurality of disposable gloves. The container has a plurality of faces, and each glove has a cuff portion and a finger portion, the cuff portion having a cuff and the gloves being stacked one on another with the cuffs of the gloves being aligned on one side of the stack of gloves held within the container. The container has in use a dispensing aperture in at least one face of the container through which gloves can be dispensed. The gloves are oriented in the container so that the gloves are positioned for dispensing cuff-first through the aperture, and the finger portion of each glove is folded back against the cuff portion of the same glove to protect the finger portion from user contact and contamination during dispensing of the glove. The dispensing aperture includes a portion of the aperture that extends across a portion of a face. However, the manufacturing process is complex due to the additional machinery required to fold and overlap the gloves.

EP 2 004 519 B1 discloses a dispensing assembly which includes a dispenser having a housing comprising a plurality of walls which cooperate to form an inner surface and an internal compartment. The dispenser is configured to hold a stack of gloves and a stack of gloves is disposed in the dispenser. The dispenser includes a pair of spaced-apart dispensing openings. The stack of gloves is positioned on a glove positioner having a pair of opposing ends such that gloves are positioned in a stack cuff-to-cuff at each end of the glove positioner which positions each cuff of a glove adjacent one of the dispensing openings. A first glove positioner includes a resilient material which biases the first stack of gloves toward the dispensing opening. A second glove positioner includes a resilient material which biases the second stack of gloves toward the dispensing opening. The stack of gloves is biased against the dispensing openings to permit easy and reliable withdrawal of each glove therefrom. However, additional components such as the resilient material would be required, increasing manufacturing costs. Further the manufacturing process is complex due to the additional components that need to be assembled.

GB 2 451 450 A discloses a dispenser for dispensing disposable gloves from a container in which they are packed as a stack of gloves lying all in the same orientation and unfolded with the cuffs of the gloves being aligned on one side of the stack of gloves. The container has a dispensing aperture in one face of the container through which the gloves
5 can be dispensed. The aperture extends up to an edge of the face, but not beyond the edge of the face. A plate bears on the bottom of the stack of gloves, and a spring pushes the stack up in the box towards the dispensing aperture. However, additional components such as the plate and springs would be required, increasing manufacturing costs. Further the manufacturing process is complex due to the amount of components that need to be
10 assembled.

Accordingly, there is a need for a dispenser for disposable gloves which is configured to hold and dispense a plurality of gloves cuff-first without incurring additional manufacturing costs or processes. Such a dispenser assembly desirably permits a plurality of gloves to be easily dispensed one at a time. In addition, the opening to the dispenser
15 is desirably configured and positioned such that minimal surface area of the glove adjacent the opening is exposed.

SUMMARY OF THE INVENTION

In accordance with an aspect of the invention, there is provided a dispenser for gloves that comprises:

- 5 a box having a plurality of faces, the box having perforated lines on at least two opposing faces, where said perforated lines are tearable providing a respective dispensing aperture on each opposing face;
- two stacks of unfolded gloves disposed in the box, where each stack of gloves is orientated in the box so that the cuff of the gloves are positioned adjacent to the dispensing aperture; and
- 10 a static internal separator positioned between each stack of gloves.

The invention thus allows the gloves to be for dispensed cuff-first through a respective dispensing aperture preventing contamination of one or more gloves. Further, as the finger portions of the gloves are not exposed prior to dispensing, any contamination from the user upon touching the glove for dispensing is limited to the cuff portion of the glove. The manufacturing process is simplified as no additional components such as plates and springs would need to be assembled.

The static internal separator according to the invention allows two stacks of gloves to be 20 disposed in the box permitting dispensing of the gloves from two opposing apertures.

In a preferred embodiment of the invention, the gloves in each stack are stacked unfolded one on another cuff-to-cuff and the dispenser is arranged in use to dispense the glove from one aperture. Once gloves have been dispensed from one stack of gloves, the 25 box is turned upside-down for dispensing of the gloves from the opposing aperture.

The unfolded arrangement of the gloves according to the invention provides the benefit of where the user does not have to place his/her hand deep into the dispenser to dispense a single glove as there is less space between the top of the glove and the 30 aperture, as compared to when gloves are stacked folded.

In an embodiment, the static internal separator is a single sheet element having end tabs used to support the separator within the box.

In a preferred embodiment, the sheet element comprises a gradient portion between the end tabs. The invention thus allows the gloves to slide cuff out first and also prevents the gloves from moving backwards when a glove is withdrawn. Since the cuff of each glove is often thicker, the gradient portion allows for a stack of gloves on each side of the separator and each stack is generally trapezoidal in shape. The problem previously caused due to an asymmetry of a stack of gloves stacked cuff-to-cuff is solved by using the trapezoidal cross-section of the stacks of gloves to fill a rectangular dispenser, thereby removing or controlling unwanted space which results from the asymmetry and from dispensing and depleting the gloves from the dispenser.

10

In a further embodiment, the sheet element further comprises a flat portion for placement of the cuff of the gloves, where the flat portion is disposed between the gradient portion and the flat portions. The flat portion according to the invention is used to support the cuffs of the gloves.

15

In an embodiment, the sheet element comprises fold lines between the gradient portion and the flat portion.

In another embodiment, the end tabs of the sheet element are bent in opposing directions.

20

In an embodiment, the end tabs of the sheet element are positioned parallel to the opposing faces such that the end tabs come in contact with the opposing faces. This allows the cuffs of the gloves to be supported.

25

In a further embodiment, the box has a further set of tearable perforated lines adjoining the perforated lines to extend the aperture to an adjoining face. The invention thus allows the gloves to be easily dispensed cuff-first through a dispensing aperture.

In an embodiment, the perforated lines define a flap having a closed position and an open position to close or open the dispensing aperture. Thus, the flap shields the dispensing aperture from the entry of contaminants into the box from the surrounding environment.

30

In another embodiment, the static internal separator is two sheet elements, each sheet element having a flat portion for receiving a respective stack of gloves and side tabs used to support the sheet elements within the box.

- 5 In a preferred embodiment, the flat portions of each sheet elements are disposed on one another.

In a further embodiment, the side tabs of the separator are positioned parallel to the side faces of the box. This allows the gloves to be supported.

10

In an embodiment, the dispensing aperture is covered by a film having a slit for each glove to pass through. Thus, the film shields the dispensing aperture from the entry of contaminants into the box from the surrounding environment.

- 15 Additional advantages of the dispenser for gloves of this invention will be elaborated in the following pages.

BRIEF DESCRIPTION OF THE DRAWINGS

Figure 1A is a perspective view of a dispenser for dispensing gloves showing a static internal separator and a box having a flap defined by perforations on the front face and back face of the box such that, when opened by tearing, a dispensing aperture is provided.

Figure 1B is a perspective view of a dispenser for dispensing gloves showing a static internal separator and a box having a flap defined by perforations on the upper face and lower face of the box such that, when opened by tearing, a dispensing aperture is provided.

Figure 2A is a top view of a static internal separator when laid flat.

Figure 2B is a top view of a static internal separator when laid flat, in another embodiment.

Figure 3A is a sectional view showing the position of the static internal separator when aligned on a gradient.

Figure 3B is a sectional view showing the position of the static internal separators when aligned flat.

Figure 4A is a sectional view similar to Figure 1A, but showing the position of the static internal separator when aligned on a gradient and is fully loaded with gloves positioned on the static internal separator.

Figure 4B is a sectional view similar to Figure 1B, but showing the position of the static internal separator when aligned flat and is fully loaded with gloves positioned on the static internal separator.

DETAILED DESCRIPTION

Figures 1A and 1B shows a dispenser for dispensing gloves in the form of a box 10 with an upper face 11, lower face 12, front face 13, back face 14 and side faces 15. The width of the box 10 corresponds broadly to the width of a glove laid flat in the box 10 measured from the thumb to the little finger. The length of the box corresponds broadly to the length of a glove laid flat in the box 10 measured from the cuff to the middle finger. The height of the box 10 corresponds broadly to the total height of the gloves in the box 10 measured on its cuff side. Therefore, the side faces 15 have a length greater than the width of the front and back faces 13, 14. Also, in this embodiment, the width of the front and back faces 13, 14 is greater than the height of the box.

In Figure 1A, the box 10 has a first set of perforated lines 110, 120. Perforated lines 110 are positioned on the front face 13. The perforated lines 110 are straight and begin from the edge of the front face 13 that is perpendicular to the upper face 11 towards the middle of the front face 13. Perforated lines 120 are positioned on the back face 14. The perforated lines 120 are straight and begin from the edge of the back face 14 that is perpendicular to the lower face 12 towards the middle of the back face 14.

When the perforated lines are torn, flaps 130, 140 are formed and dispensing apertures 150, 160 are provided. A portion of the front face 13 and back face 14 conveniently becomes a hinge.

Also in Figure 1A, and according to another embodiment, the box 10 has a second set of perforated lines 111, 121.

Perforated lines 111 are positioned on the upper face 11. The perforated lines 111 are straight and begin from the edge of the upper face 11 that is perpendicular to the front face 13 towards the middle of the upper face 11. Perforated lines 121 are positioned on the lower face 12. The perforated lines 121 are straight and begin from the edge of the lower face 12 that is perpendicular to the back face 14 towards the middle of the lower face 12.

When the perforated lines are torn, flaps 131, 141 are formed and additional dispensing apertures 151, 161 are provided. A portion of the upper face 11 and lower face 12 conveniently becomes a hinge.

The dispensing apertures 150, 160, 151, 161 are desirably sized and configured to permit one-at-a-time dispensing of a plurality of gloves. Therefore, the dispensing apertures 150, 160, 151, 161 are positioned on the box 10 to permit reasonably easy access to a user without causing excessive dispensing. It will be understood that the dispensing apertures
5 150, 160, 151, 161 may assume any other suitable configuration that meet these requirements.

The flaps 130, 140, 131, 141 are used as a means for shielding the dispensing apertures 150, 160, 151, 161 from the entry of contaminants from the surrounding environment. The flaps 40, 41 have a closed position and an open position. In the open position (as
10 shown), the flaps 130, 140, 131, 141 allow a glove to be removed by a user from the box 10 through the dispensing apertures 30, 31.

The problem of unwanted space in the box 10 caused by a stack of gloves may be greatly reduced or eliminated when two stacks of gloves are provided, one stack positioned on each side of a separator. The separator is static. Desirably, a separator allows for
15 separate dispensing through the dispensing apertures 150, 160, 151, 161 associated with each stack.

In Figure 2A, the separator is a single sheet element 170 having inner fold lines 173 and outer fold lines 174.

In Figure 3A, the sheet element 170 is bent about the outer fold lines 174, end tabs 171
20 form at each end of the sheet element 170. Each end tab 171 can be bent up and down. The flat portion 172 between inner fold lines 173 and outer fold lines 174 is used to support the cuffs of the gloves. In a preferred embodiment, one tab is bent upwards while the other tab is bent downwards. The end tabs 171 prevent from upward or downward movement of the internal separator. The height of the end tab 171 when bent
25 about the outer fold lines 174 must be at least of the height as the cuff end of a stack of gloves.

In a preferred embodiment, the end tabs 171 are positioned touching the inside surface of the front and back face 13, 14, forming an inclined slope. To allow for an inclined slope, the total length of the sheet element 170 in Figure 2A is longer compared to that
30 of the length of the sheet 270 in Figure 2B. The gradient positioning of the separator 170 ensures that the gloves slide cuff out first and also prevents the gloves from moving

backwards when a glove is withdrawn. Such a configuration is also used to avoid asymmetry. That is, the cuff of each glove is often thicker.

The separator 170 may couple to the box 10 via any known manner, such as, by way of non-limiting example, heat sealing, stapling, adhering via adhesives and so forth. In a preferred embodiment, the separator is not coupled to the box 10 where the separator
5 170 is simply placed in the box 10 in a snug-fit manner. This reduces manufacturing costs as no coupling components are required.

In Figure 4A, a first stack of gloves 60 is placed in the box 10. The first stack 60 is oriented so that the gloves are stacked cuff-to-cuff (or wrist-to-wrist). The cuffs are
10 positioned adjacent to the dispensing aperture 150 of the front face 13. The second stack 61 is also oriented so that the gloves are stacked cuff-to-cuff (or wrist-to-wrist). Each stack of gloves is aligned cuff-to-cuff (or wrist-to-wrist), with the cuffs of each stack is on opposing ends. This is to ensure that the overall thickness of the gloves in the box is symmetrical. The cuffs are positioned adjacent to the dispensing aperture 160 of the back
15 face 14. The single sheet element 170 is positioned between the first and second stacks of gloves 60, 61.

In an embodiment as shown in Figure 1B, the box 10 includes perforated lines 211 which are positioned on the upper face 11 and perforated lines 221 which are positioned on the lower face 12. When the perforated lines 211, 221 are torn, a dispensing aperture 251,
20 261 is provided. The perforated lines 211, 221 form a generally oval shape aperture.

In a preferred embodiment, a film 280 having a slit is used as a means for shielding the dispensing apertures 251, 261 from the entry of contaminants from the surrounding environment.

The dispensing apertures 251, 261 is desirably sized and configured to permit one-at-a-time dispensing of a plurality of gloves through the slit. Therefore, the dispensing
25 aperture 251, 261 is positioned on the box 10 to permit reasonably easy access to a user without causing excessive dispensing. It will be understood that the dispensing aperture 30 may assume any other suitable configuration that meet these requirements.

The problem of unwanted space in the box 10 caused by a stack of gloves may be greatly
30 reduced or eliminated when two stacks of gloves are provided, one stack positioned on

each side of a separator. Desirably, the separator allows for separate dispensing through the dispensing aperture 251, 261 associated with each stack.

In Figure 2B, the separator is static and consists of two sheet elements 270, each sheet element having outer fold lines 274.

5 In Figure 3B, each sheet element 270 is bent about the outer fold lines 274, side tabs 271 form on each side of the sheet. Preferably, each sheet element 270 is bent about the outer fold lines 274 in the same direction. The side tabs 271 are positioned touching the inside surface of the side faces 15. The side tabs 271 prevent from upward or downward movement of the she sheets 270. The height of the side tab 271 when bent about the
10 outer fold lines 274 must be at least of the height as the cuff end of a stack of gloves. The flat portions 272 of the sheet elements 270 are placed on top of each other.

The sheet elements 270 may couple to the box 10 via any known manner, such as, by way of non-limiting example, heat sealing, stapling, adhering via adhesives and so forth. In a preferred embodiment, the separator is not coupled to the box 10 where the sheet
15 elements 270 are simply placed in the box 10 in a snug-fit manner. This reduces manufacturing costs as no coupling components are required.

In Figure 4B, a first stack of gloves 60 is placed in the box 10. The first stack 60 is oriented so that the gloves are stacked cuff-to-cuff (or wrist-to-wrist). The cuffs are positioned adjacent to the dispensing aperture 251 of the upper face 11. The second
20 stack 61 is also oriented so that the gloves are stacked cuff-to-cuff (or wrist-to-wrist). The cuffs are positioned adjacent to the dispensing aperture 261 of the lower face 12. Each stack of gloves is aligned cuff-to-cuff (or wrist-to-wrist), with the cuffs of each stack is on opposing ends. This is to ensure that the overall thickness of the gloves in the box is symmetrical. The sheets 270 are positioned between the first and second stack of gloves
25 60, 61.

In an embodiment, each stack of gloves 60, 61 comprises of fifty gloves. In another embodiment, each stack of gloves 60, 61 comprises of one hundred gloves.

In an exemplary usage of the dispenser in accordance with the invention, gloves are dispensed from one aperture at a time. Once all the gloves have been dispensed from an

aperture, the box 10 is turned upside down so that the gloves may be dispensed from the opposing aperture.

The box 10 and the separators 170, 270 may be constructed from any material or combination of materials which permit it to operate as shown and/or described herein.

5 Such materials may include, for example, but not by way of limitation, cardboard, paperboard, plastic, metal, polymer film, and so forth.

It will be understood that the invention may be embodied in ways other than those specifically described without departure from its scope as defined by the claims.

CLAIMS

1. A dispenser for gloves comprising:
a box (10) having a plurality of faces (11, 12, 13, 14), wherein
5 said box having a set of perforated lines (110, 120) on two opposing faces,
 where said perforated lines are tearable providing a respective dispensing
 aperture (150, 160) on each opposing face;
 two stacks of unfolded gloves (60, 61) disposed in said box, wherein
 each stack of gloves is orientated in the box so that the cuff of the gloves
10 are positioned adjacent to the dispensing aperture for dispensing cuff-first
 through said dispensing aperture; and
 a static internal separator (170, 270) positioned between the stacks of gloves.

2. The dispenser for gloves of claim 1, wherein said static internal separator is a
15 single sheet element (170) having end tabs (171) used to support the separator within
 the box (10).

3. The dispenser for gloves of claim 2, wherein said sheet element (170) comprises a
20 gradient portion between the end tabs (171).

4. The dispenser for gloves of claim 3, wherein said sheet element (170) further
 comprises a flat portion (172) for placement of the cuff of the gloves, the flat portion
 disposed between the gradient portion and each end tab.

- 25 5. The dispenser for gloves of claim 4, wherein said sheet element (170) comprises
 fold lines (173) between the gradient portion and the flat portions (172).

6. The dispenser for gloves in any of claims 2 to 5, wherein the end tabs (171) of the
 sheet element (170) are bent in opposing directions.
30

7. The dispenser for gloves in any of claims 2 to 6, wherein the end tabs (171) of the
 sheet element (170) are positioned parallel to the front face (13) and back face (14).

8. The dispenser for gloves in any of claims 2 to 7, wherein said box (10) has a further set of tearable perforated lines (111, 121) adjoining said set of perforated lines (110, 120) to extend the aperture (150, 151; 160,161) to an adjoining face (13, 14).
- 5 9. The dispenser for gloves in any of claims 2 to 8, wherein said sets of perforated lines (110, 120, 111, 121) define a flap (130, 140; 131, 141) have a closed position and an open position to close or open said dispensing aperture (150, 160; 151, 161).
- 10 10. The dispenser for gloves of claim 1, wherein said static internal separator (50) is two sheet elements (270), each sheet element having a flat portion (272) for receiving a respective one of said stacks of gloves, and side tabs (271) used to support the sheet elements (270) within the box (10).
- 15 11. The dispenser for gloves of claim 10, wherein the flat portions (272) are disposed on one another.
12. The dispenser for gloves in any of claims 9 to 10, wherein the side tabs (271) of the separator are positioned parallel to the side faces (15) of the box (10).
- 20 13. The dispenser for gloves in any of claims 9 to 11, wherein said aperture (251, 261) is covered by a film (280) having a slit for each glove to pass through.

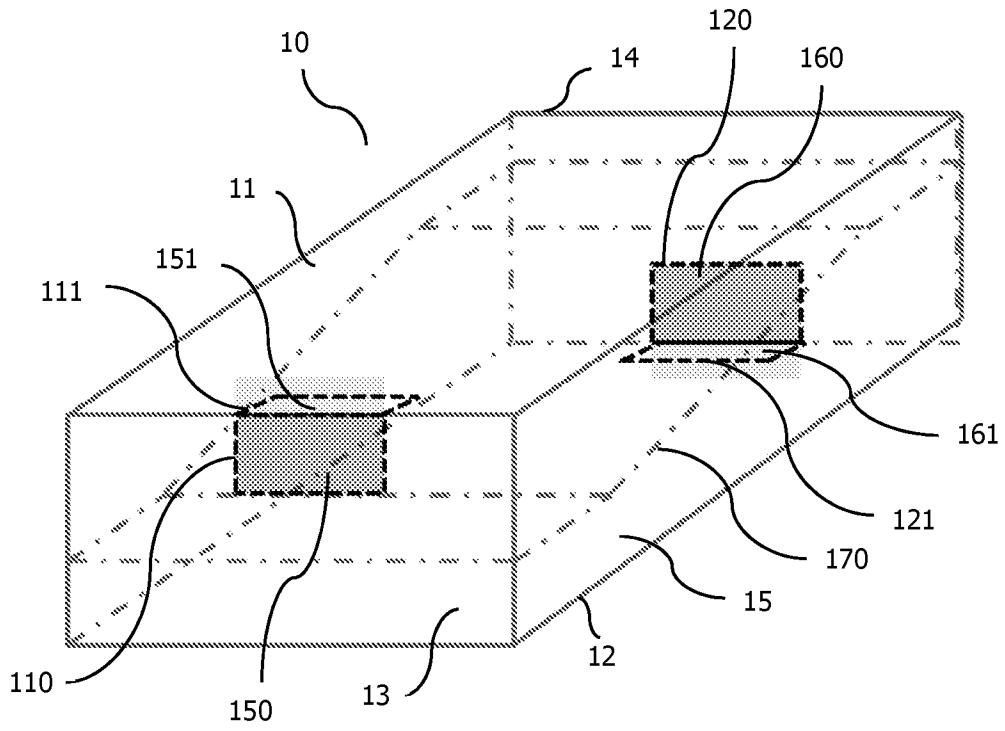

Figure 1A

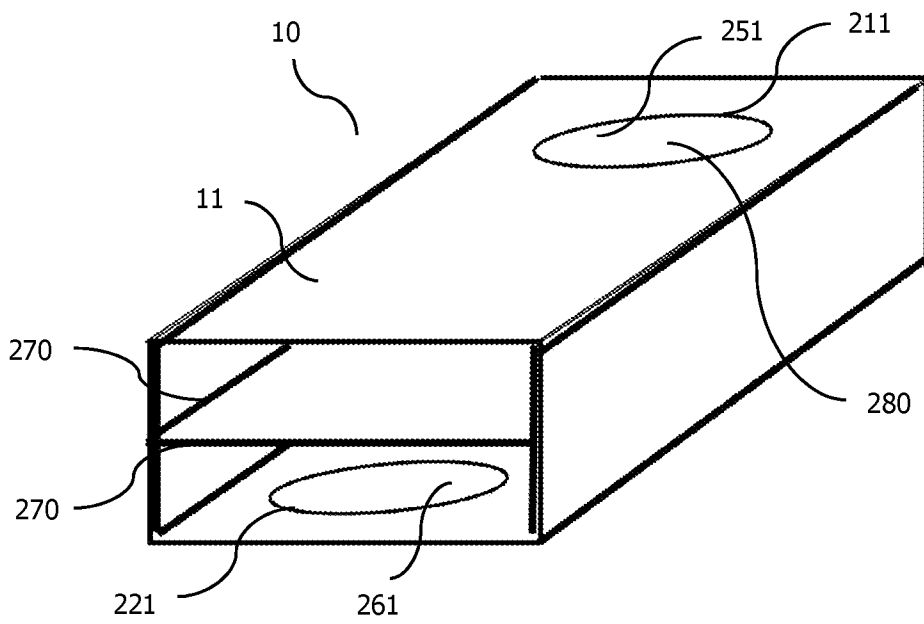

Figure 1B

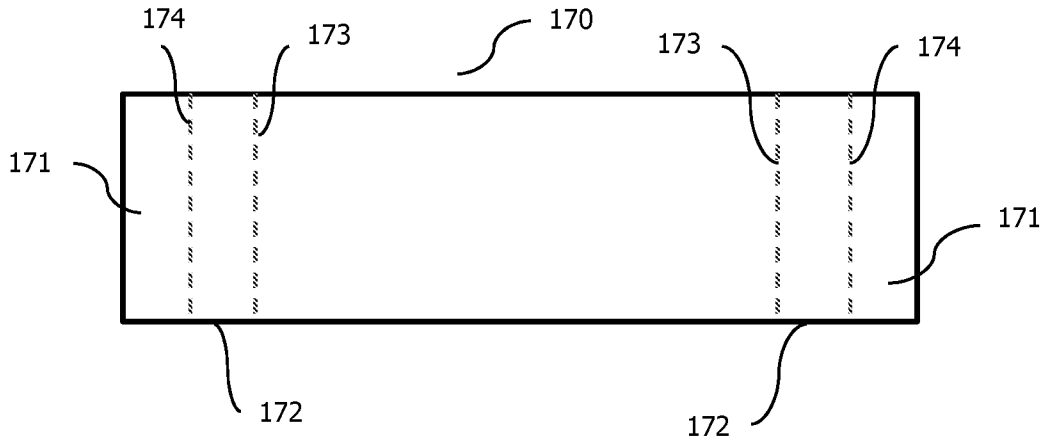

Figure 2A

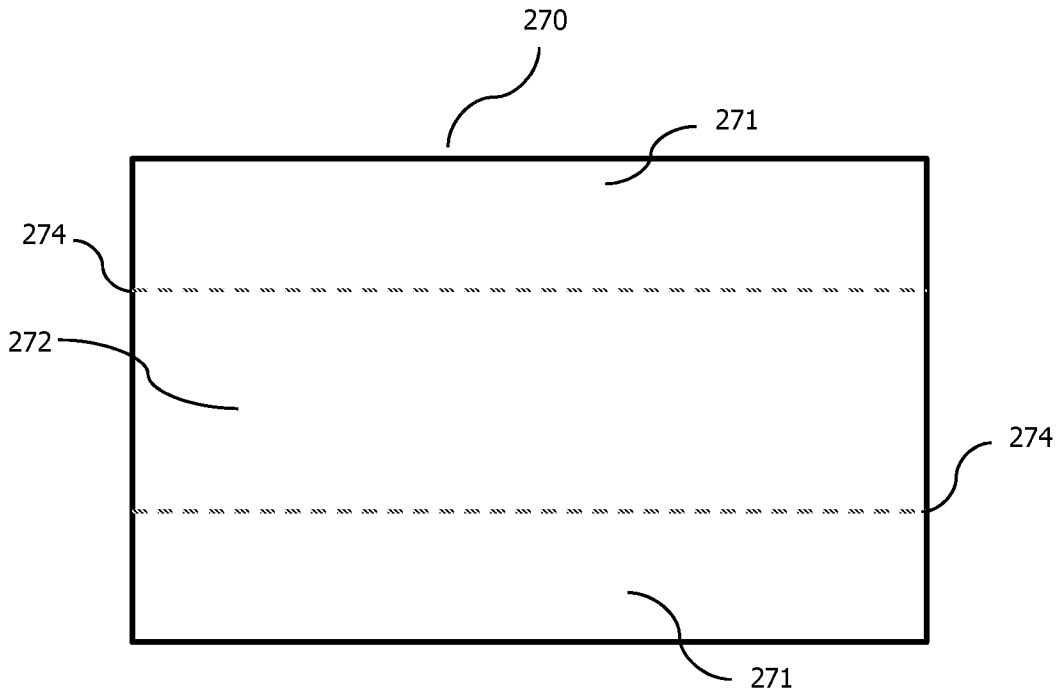

Figure 2B

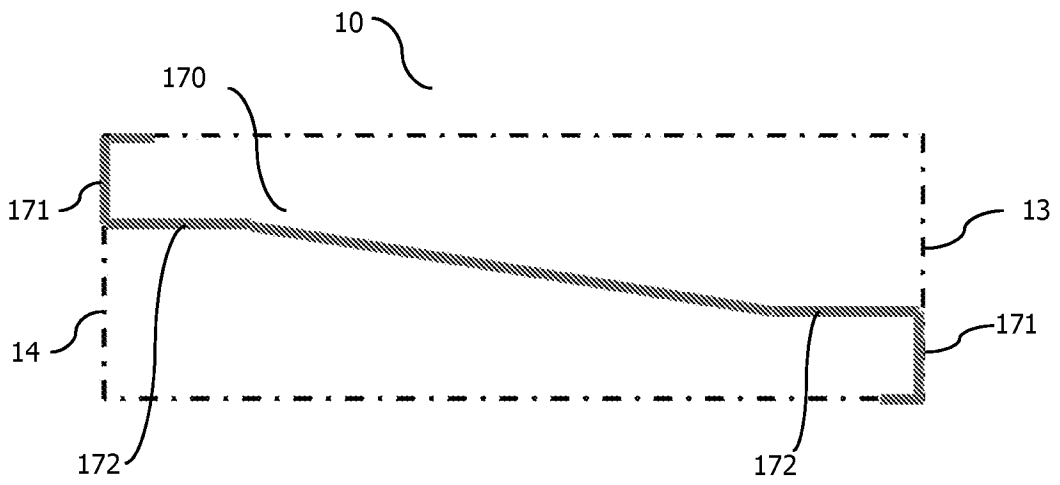

Figure 3A

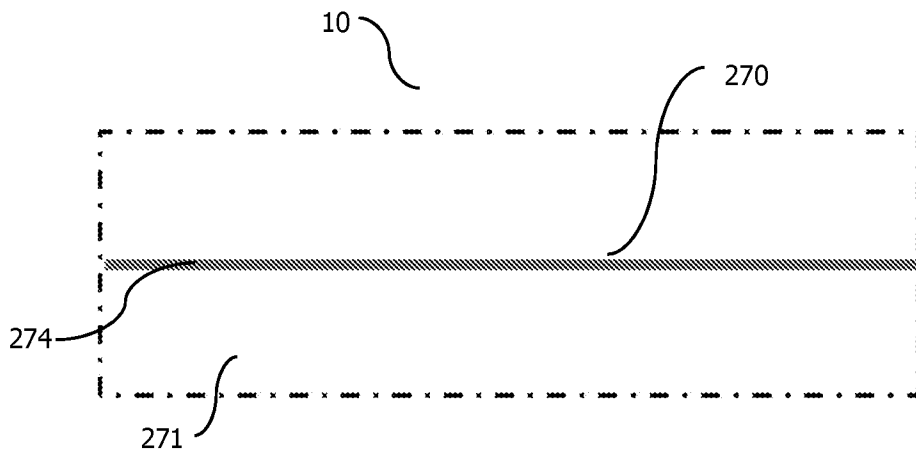

Figure 3B

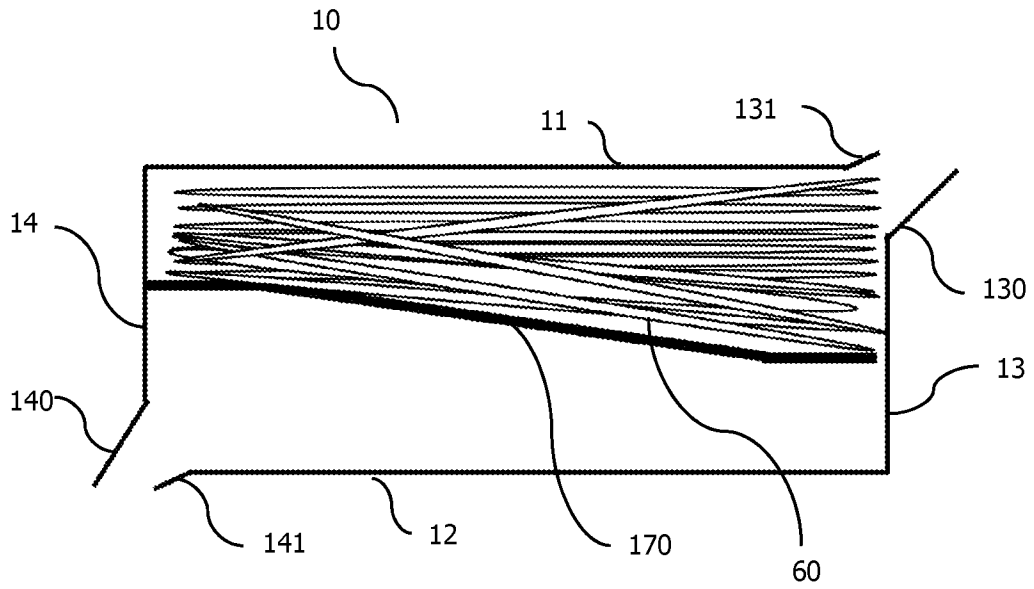

Figure 4A

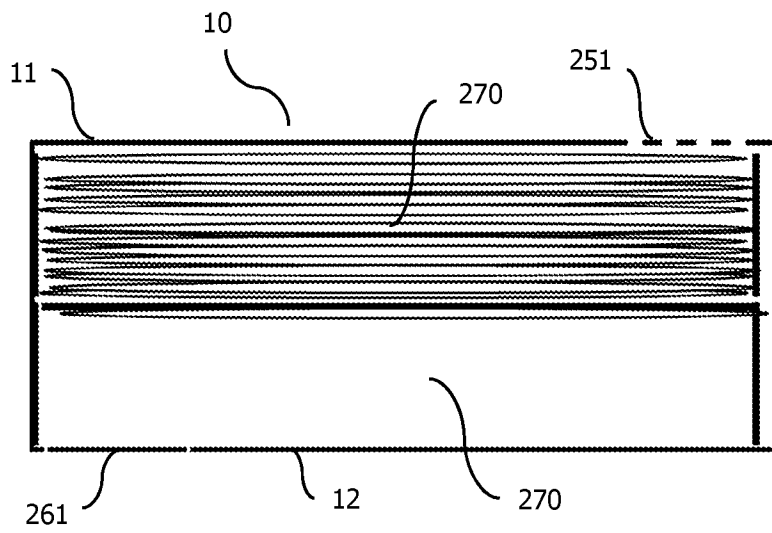

Figure 4B

A. CLASSIFICATION OF SUBJECT MATTER**B65D 83/08(2006.01)i, B65D 5/54(2006.01)i, B65D 77/38(2006.01)i, B65D 5/49(2006.01)i**

According to International Patent Classification (IPC) or to both national classification and IPC

B. FIELDS SEARCHED

Minimum documentation searched (classification system followed by classification symbols)

B65D 83/08; A47K 10/42; B65D 5/72; B65H 001/00; B65H 001/08; B65H 1/00; B65D 5/54; B65D 77/38; B65D 5/49

Documentation searched other than minimum documentation to the extent that such documents are included in the fields searched

Korean utility models and applications for utility models

Japanese utility models and applications for utility models

Electronic data base consulted during the international search (name of data base and, where practicable, search terms used)

eKOMPASS(KIPO internal) & Keywords: glove, dispenser, box, separator and plate

C. DOCUMENTS CONSIDERED TO BE RELEVANT

Category*	Citation of document, with indication, where appropriate, of the relevant passages	Relevant to claim No.
Y	US 2007-0215628 A1 (TRAMONTINA, PAUL FRANCIS) 20 September 2007 paragraphs [0055], [0060] and figures 7-8	1-13
Y	JP 3202591 U (FP CORP. et al.) 12 February 2016 paragraphs [0020], [0028] and figures 1, 11	1-13
A	JP 05-055987 U (IGARI, KIMIO) 27 July 1993 abstract and figures 1-2	1-13
A	US 2004-0182874 A1 (KRINGEL et al.) 23 September 2004 paragraphs [0005]-[0009] and figure 1	1-13
A	US 2018-0105348 A1 (AVENT, INC.) 19 April 2018 claim 1 and figures 3-4	1-13

 Further documents are listed in the continuation of Box C. See patent family annex.

* Special categories of cited documents:

"A" document defining the general state of the art which is not considered to be of particular relevance

"D" document cited by the applicant in the international application

"E" earlier application or patent but published on or after the international filing date

"L" document which may throw doubts on priority claim(s) or which is cited to establish the publication date of another citation or other special reason (as specified)

"O" document referring to an oral disclosure, use, exhibition or other means

"P" document published prior to the international filing date but later than the priority date claimed

"T" later document published after the international filing date or priority date and not in conflict with the application but cited to understand the principle or theory underlying the invention

"X" document of particular relevance; the claimed invention cannot be considered novel or cannot be considered to involve an inventive step when the document is taken alone

"Y" document of particular relevance; the claimed invention cannot be considered to involve an inventive step when the document is combined with one or more other such documents, such combination being obvious to a person skilled in the art

"&" document member of the same patent family

Date of the actual completion of the international search

16 March 2020 (16.03.2020)

Date of mailing of the international search report

16 March 2020 (16.03.2020)

Name and mailing address of the ISA/KR

International Application Division

Korean Intellectual Property Office

189 Cheongsa-ro, Seo-gu, Daejeon, 35208, Republic of Korea

Facsimile No. +82-42-481-8578

Authorized officer

HWANG, Chan Yoon

Telephone No. +82-42-481-3347



INTERNATIONAL SEARCH REPORT

Information on patent family members

International application No.

PCT/MY2019/050087

Patent document cited in search report	Publication date	Patent family member(s)	Publication date
US 2007-0215628 A1	20/09/2007	AU 2007-227768 A1 AU 2007-227768 B2 BR PI0706439 A2 EP 2004519 A1 EP 2004519 B1 KR 10-1366547 B1 KR 10-2008-0103553 A MX 2008011884 A US 7699189 B2 WO 2007-108860 A1	27/09/2007 01/08/2013 29/03/2011 24/12/2008 26/10/2011 25/02/2014 27/11/2008 29/09/2008 20/04/2010 27/09/2007
JP 3202591 U	12/02/2016	None	
JP 05-055987U	27/07/1993	None	
US 2004-0182874 A1	23/09/2004	US 7000802 B2	21/02/2006
US 2018-0105348 A1	19/04/2018	AU 2016-256327 A1 AU 2016-256328 A1 AU 2016-256329 A1 AU 2016-256330 A1 BR 112017023298 A2 CA 2983586 A1 CA 2983587 A1 CA 2983591 A1 CA 2983607 A1 CN 107567417 A EP 3288855 A1 EP 3288856 A1 EP 3288856 B1 EP 3288857 A1 EP 3288858 A1 JP 2018-514468 A JP 2018-514469 A JP 2018-514470 A JP 2018-514471 A KR 10-2017-0140223 A MX 2017012385 A MX 2017012523 A MX 2017012525 A MX 2017012529 A RU 2017135469 A RU 2017135469 A3 US 10414577 B2 US 2018-0111744 A1 US 2018-0111745 A1 US 2018-0162628 A1 US 2019-0352084 A1 WO 2016-176016 A1	12/10/2017 12/10/2017 12/10/2017 12/10/2017 14/08/2018 03/11/2016 03/11/2016 03/11/2016 03/11/2016 09/01/2018 07/03/2018 07/03/2018 29/01/2020 07/03/2018 07/03/2018 07/06/2018 07/06/2018 07/06/2018 07/06/2018 20/12/2017 14/12/2017 30/01/2018 30/01/2018 18/01/2018 30/05/2019 30/05/2019 17/09/2019 26/04/2018 26/04/2018 14/06/2018 21/11/2019 03/11/2016

INTERNATIONAL SEARCH REPORT

Information on patent family members

International application No.

PCT/MY2019/050087

Patent document cited in search report	Publication date	Patent family member(s)	Publication date
		WO 2016-176017 A1	03/11/2016
		WO 2016-176018 A1	03/11/2016
		WO 2016-176019 A1	03/11/2016