



- (51) International Patent Classification:  
*G02B 27/01* (2006.01)
- (21) International Application Number:  
PCT/US2017/064898
- (22) International Filing Date:  
06 December 2017 (06.12.2017)
- (25) Filing Language: English
- (26) Publication Language: English
- (30) Priority Data:  
15/390,363 23 December 2016 (23.12.2016) US
- (71) Applicant: **REALWEAR, INCORPORATED** [US/US];  
1851 McCarthy Boulevard, Suite 120, Milpitas, California  
95035 (US).
- (72) Inventors: **POMBO, Stephen A.**; 976 Harrison Ave,  
Campbell, California 95008 (US). **HINES, George Hen-**  
**ry**; 3039 Octavia Street, San Francisco, California 94123  
(US). **PARKINSON, Christopher Iain**; 2006 Harris Av-  
enue, Richland, Washington 99354 (US). **JHAWAR, San-**  
**jay Subir**; 440 Gilbert Avenue, Menlo Park, California
- 94025 (US). **LUSTIG, Kenneth**; 3820 East Mercer Way,  
Mercer Island, Washington 98040 (US).
- (74) Agent: **STROBEL, Christopher J.**; Shook, Hardy, & Ba-  
con, LLP, 2555 Grand Blvd., Kansas City, Missouri 64108  
(US).
- (81) Designated States (*unless otherwise indicated, for every  
kind of national protection available*): AE, AG, AL, AM,  
AO, AT, AU, AZ, BA, BB, BG, BH, BN, BR, BW, BY, BZ,  
CA, CH, CL, CN, CO, CR, CU, CZ, DE, DJ, DK, DM, DO,  
DZ, EC, EE, EG, ES, FI, GB, GD, GE, GH, GM, GT, HN,  
HR, HU, ID, IL, IN, IR, IS, JO, JP, KE, KG, KH, KN, KP,  
KR, KW, KZ, LA, LC, LK, LR, LS, LU, LY, MA, MD, ME,  
MG, MK, MN, MW, MX, MY, MZ, NA, NG, NI, NO, NZ,  
OM, PA, PE, PG, PH, PL, PT, QA, RO, RS, RU, RW, SA,  
SC, SD, SE, SG, SK, SL, SM, ST, SV, SY, TH, TJ, TM, TN,  
TR, TT, TZ, UA, UG, US, UZ, VC, VN, ZA, ZM, ZW.
- (84) Designated States (*unless otherwise indicated, for every  
kind of regional protection available*): ARIPO (BW, GH,  
GM, KE, LR, LS, MW, MZ, NA, RW, SD, SL, ST, SZ, TZ,  
UG, ZM, ZW), Eurasian (AM, AZ, BY, KG, KZ, RU, TJ,  
TM), European (AL, AT, BE, BG, CH, CY, CZ, DE, DK,  
EE, ES, FI, FR, GB, GR, HR, HU, IE, IS, IT, LT, LU, LV,

(54) Title: INTERCHANGEABLE OPTICS FOR A HEAD-MOUNTED DISPLAY

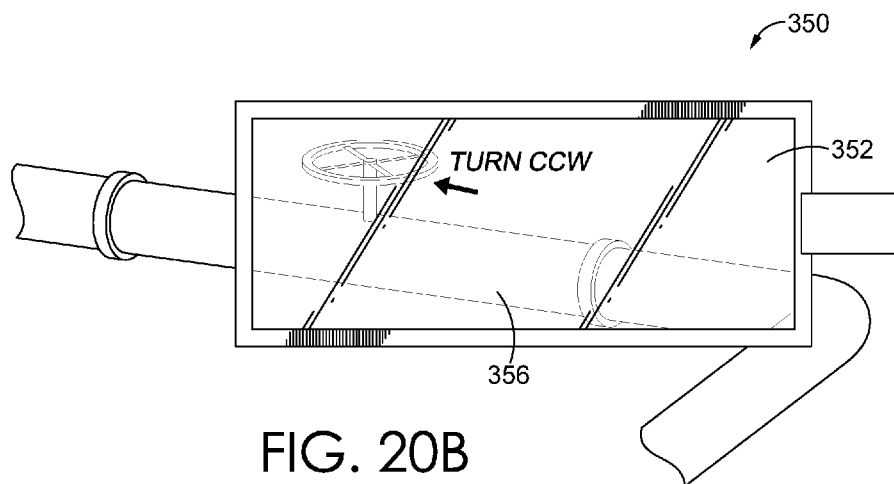

FIG. 20B

(57) Abstract: A head-mounted display that is modular and configured for securement to an item of headwear is provided. The head-mounted display may comprise a selection of components that are desired for a particular application, such as a display boom, camera, microphone, position-tracking component, etc., and may include an attachment mechanism for securing the selection of components to the item of headwear. The head-mounted display may include a display module having a corresponding display characteristic that provides a visual display and/or display functionality that is appropriate for a particular application. The display module may include a micro display that is non-transparent and/or a waveguide optic that is at least partially transparent, and may be configured to provide an augmented reality display for a user.



MC, MK, MT, NL, NO, PL, PT, RO, RS, SE, SI, SK, SM,  
TR), OAPI (BF, BJ, CF, CG, CI, CM, GA, GN, GQ, GW,  
KM, ML, MR, NE, SN, TD, TG).

**Declarations under Rule 4.17:**

- *as to applicant's entitlement to apply for and be granted a patent (Rule 4.17(ii))*
- *as to the applicant's entitlement to claim the priority of the earlier application (Rule 4.17(iii))*

**Published:**

- *with international search report (Art. 21(3))*

## INTERCHANGEABLE OPTICS FOR A HEAD-MOUNTED DISPLAY

### FIELD OF THE INVENTION

The field relates to head-mounted displays.

### BACKGROUND OF THE INVENTION

5           Head-mounted displays are sometimes used to allow a user to mount technology on or around their head, allowing the user to transport and use different technologies with greater ease and flexibility. Head-mounted displays also allow a user to have interaction with the technology while otherwise remaining engaged in other tasks. However, in certain circumstances, a head-mounted display with greater flexibility, 10 modularity, and mountability, among other aspects, is needed.

### SUMMARY OF THE INVENTION

This summary is intended to introduce a selection of concepts in a simplified form that are further described below in the detailed description section of this disclosure. This summary is not intended to identify key or essential features of the claimed subject 15 matter, nor is it intended to be used as an aid in determining the scope of the claimed subject matter.

In brief, and at a high level, this disclosure describes, among other things, a head-mounted display having a modular design that allows a number of different components to be used in an interchangeable fashion, and additionally, describes an attachment 20 mechanism for securing the head-mounted display to an item of headwear appropriate for a particular application, such as one requiring head, eye, and/or ear protection. Exemplary components used with a head-mounted display may include a computer processor, a display boom, a camera, and/or a display module, for example. The display module may be releasably attachable to the head-mounted display, and may be configured to provide a 25 selected display characteristic. Different display modules may be used to provide different display characteristics and functionality, and as such, a head-mounted display that may be used in a variety of different applications is provided.

In one embodiment of the present technology, a head-mounted display is provided. The head-mounted display comprises a base, a display boom having a first end and a second end, the display boom movably coupled to the base at the second end, a display module coupled to the first end of the display boom, one or more computer processors communicatively coupled to the display module, a power source, and an attachment mechanism for releasably securing the display module, the display boom, the one or more computer processors, and the power source to an item of headwear. The attachment mechanism comprises one or more rigid coupling elements and one or more securing straps coupled to the one or more rigid coupling elements for securing about the item of headwear.

10 In another embodiment of the present technology, a head-mounted display is provided. The head-mounted display comprises a display boom comprising a first end and a second end, a display module coupled to the display boom between the first end and the second end, one or more computer processors communicatively coupled to the display module, a power source connected to the one or more computer processors and to the display module, and an attachment mechanism for releasably securing the display module, the display boom, the one or more computer processors, and the power source to an item of headwear. The attachment mechanism comprises one or more rigid coupling elements and one or more securing straps coupled to the one or more rigid coupling elements for securing about the item of headwear. The one or more rigid coupling elements comprise at least a first rigid coupling element having a first rotatable coupling secured to the first end of the display boom and a second rigid coupling element having a second rotatable coupling secured to the second end of the display boom.

25 In another embodiment of the present technology, a head-mounted display is provided. The head-mounted display comprises a display boom comprising a first end and a second end, a display module coupled to the display boom at the first end, and a sound-dampening ear-cover assembly coupled to the display boom at the second end, the sound-dampening ear-cover assembly comprising a first portion and a second portion that are movably coupled to each other, the sound-dampening ear-cover assembly adjustable between a first configuration and a second configuration. In the first configuration, the first portion and the second portion are in a first position relative to each other. In the second configuration, the first portion and the second portion are in a second position relative to each other. The head-mounted display further comprises one or more computer processors

communicatively coupled to the display module and a power source connected to the one or more computer processors and to the display module.

In another embodiment of the present technology, a head-mounted display having interchangeable components is provided. The head-mounted display comprises a first display module having a first corresponding display characteristic, a display boom comprising a first end and a second end, the display boom movably coupled to a base located at the second end, one or more computer processors communicatively coupled to the first display module, a power source connected to the one or more computer processors, and a releasable coupling. The releasable coupling comprises a first mateable coupling and a second mateable coupling, the first mateable coupling located at the first end of the display boom, and the second mateable coupling located on the first display module. The first and second mateable couplings are releasably securable to each other.

In another embodiment of the present technology, a head-mounted display having interchangeable components is provided. The head-mounted display comprises a first display module having a first corresponding display characteristic, the first display module configured to provide multiple viewing states, a display boom comprising a first end and a second end, the display boom movably coupled to a base located at the second end, one or more computer processors communicatively coupled to the first display module, a power source connected to the one or more computer processors, and a releasable coupling. The releasable coupling comprises a first mateable coupling and a second mateable coupling, the first mateable coupling located at the first end of the display boom and the second mateable coupling located on the first display module. The first and second mateable couplings are releasably securable to each other.

In another embodiment of the present technology, a method of adjusting a head-mounted display is provided. The method comprises providing a head-mounted display comprising a display boom having a first end and a second end, the display boom movably coupled to a base located at the second end, one or more computer processors, a power source, a first display module configured to provide multiple viewing states, and a releasable coupling comprising a first mateable coupling and a second mateable coupling, the first mateable coupling located at the first end of the display boom and the second mateable coupling located on the first display module. The method further comprises releasably securing the first display module to the display boom by securing the first mateable coupling to the second mateable coupling.

As used in this disclosure, the term “display module” includes any component used with a head-mounted display that is configured to provide a display characteristic that is viewable to a user. A “display characteristic” includes any viewable characteristic, such as a display state (e.g., transparent, partially transparent, non-transparent, selectively transparent, interactive, text/image/video presenting, etc.), a display type (e.g., an optic, waveguide optic, digital display, micro display (e.g., a liquid crystal display (LCD), light-emitting diode (LED) display, organic light-emitting diode (OLED) display, digital light processing (DLP) display, etc.), or any combination thereof, etc.), a display configuration (e.g., one or multiple display portions of the same or different type, display portions at different angles, display portions in different arrangements, etc.), and/or technical specifications of the display portion (e.g., resolution, pixels per inch, size, parallax, contrast, color depth, refresh rate, etc.), in addition to other display characteristics. The preceding examples are intended to be exemplary and non-limiting.

As used in this disclosure, the term “attachment mechanism” includes any one or a combination of components, separate or interconnected, configured to releasably secure, attach, affix, join, mount, and/or suspend from an item of headwear, and/or a user’s head, various components of a head-mounted display, such as those discussed herein. An attachment mechanism may include one or more of straps, clips, spring-based elements, screw-based elements, male-female connectors, elastically deformable elements, buttons, hooks, hook-and-loop fasteners, tensioning mechanisms (e.g., biasing elements, etc.), adhesives, and/or suspending elements (e.g., hangers, hooks, straps, harnesses, etc.). The preceding examples are intended to be exemplary and non-limiting.

#### BRIEF DESCRIPTION OF THE DRAWING

The present technology is described in detail herein with reference to the attached figures, which are exemplary and non-limiting in nature, wherein:

FIG. 1 is an exemplary computing environment for use with a head-mounted display, in accordance with an embodiment of the present technology;

FIG. 2A is an exemplary head-mounted display mounted on an item of headwear, in accordance with an embodiment of the present technology;

FIG. 2B is an exploded version of the head-mounted display depicted in FIG. 2A, in accordance with an embodiment of the present technology;

FIG. 2C depicts the head-mounted display of FIGS. 2A-2B with a display boom moved between different positions, in accordance with an embodiment of the present technology;

FIGS. 3A-3B depict exemplary movable couplings for a display boom of a head-mounted display, in accordance with embodiments of the present technology;

FIG. 3C depicts a partial, cross-section view of a releasable coupling for a display boom of a head-mounted display, in accordance with an embodiment of the present technology;

FIG. 3D depicts the releasable coupling of FIG. 3C engaged for releasing the display boom, in accordance with an embodiment of the present technology;

FIG. 4A is an angled, perspective, cross-section view of a strap of an attachment mechanism of a head-mounted display, in accordance with an embodiment of the present technology;

FIG. 4B is a partial, cross-section view of a component of a head-mounted display configured for securement to the strap depicted in FIG. 4A, in accordance with an embodiment of the present technology;

FIG. 5A depicts an exemplary spring-based tensioning mechanism, in accordance with an embodiment of the present technology;

FIG. 5B depicts an exemplary screw-based tensioning mechanism, in accordance with an embodiment of the present technology;

FIG. 5C depicts an elastically-deformable tensioning mechanism, in accordance with an embodiment of the present technology;

FIG. 6A depicts a partial, cross-section view of a releasable coupling for a display boom, in accordance with an embodiment of the present technology;

FIG. 6B depicts the releasable coupling of FIG. 6A engaged to release a portion of the display boom, in accordance with an embodiment of the present technology;

FIGS. 7A-7B depict an exemplary strap-based tensioning mechanism for a head-mounted display, in accordance with an embodiment of the present technology;

FIGS. 8A-8B depict an exemplary head-mounted display mounted on an item of headwear, in accordance with an embodiment of the present technology;

FIGS. 9A-9B depict exemplary display modules, in accordance with embodiments of the present technology;

FIG. 10 depicts an exemplary head-mounted display mounted on an item of headwear, in accordance with an embodiment of the present technology;

FIG. 11 depicts a harness-coupling component attached to an item of headwear, in accordance with an embodiment of the present technology;

5 FIGS. 12A-12B depict an exemplary sound-dampening ear-cover assembly without a display boom, in accordance with an embodiment of the present technology;

FIGS. 13A-13B depict a partial, cross-section view of the sound-dampening ear-cover assembly shown in FIGS. 12A-12B, in accordance with an embodiment of the present technology;

10 FIGS. 14A-14B depict the sound-dampening ear-cover assembly of FIGS. 12A-12B with a display boom mounted at different locations, in accordance with an embodiment of the present technology;

FIGS. 15A-15B depict exemplary releasable couplings for a display module, in accordance with embodiments of the present technology;

15 FIGS. 16A-16C depict a variety of display modules each having a different display characteristic, in accordance with embodiments of the present technology;

FIGS. 17A-17B depict a display module having multiple display portions, in accordance with an embodiment of the present technology;

20 FIGS. 18A-18B depict a display module with interchangeable display portions, in accordance with an embodiment of the present technology;

FIG. 19 depicts a display module having first and second display portions that provide different viewing states, in accordance with an embodiment of the present technology;

25 FIGS. 20A-20B depict a display module with a common display portion providing different viewing states, in accordance with an embodiment of the present technology; and

FIG. 21 is a block diagram of an exemplary method of adjusting a head-mounted display, in accordance with an embodiment of the present technology.

#### DETAILED DESCRIPTION OF THE INVENTION

30 The subject matter of the present technology is described with specificity in this disclosure to meet statutory requirements. However, this description is not intended to

limit the scope hereof. Rather, the claimed subject matter may be embodied in other ways, to include different steps, combinations of steps, features, and/or combinations of features, similar to the ones described in this disclosure, in conjunction with other present or future technologies. Moreover, although the terms “step” and “block” may be used to identify  
5 different elements of methods employed, the terms should not be interpreted as implying any particular order among or between various steps or blocks unless and except when the order of individual steps or blocks is explicitly described and required.

At a high level, the present technology relates generally to head-mounted displays, as well as components, configurations, and uses thereof. An exemplary head-  
10 mounted display may include a selection of components in a modular configuration, and also, may include an attachment mechanism for securing the selection of components to an item of headwear (e.g., a helmet), allowing the head-mounted display to be used in a variety of different applications. Additionally, a display module for the head-mounted display may be interchangeable and selected based on a desired corresponding display characteristic.

Turning initially to FIG. 1, a block diagram of an exemplary computing device  
15 2 suitable for use with embodiments of the present technology is provided. Computing device 2 includes a bus 18 that may directly or indirectly couple various components together, including memory 4, processor(s) 6, presentation component(s) 8, radio(s) 10, input/output (I/O) port(s) 12, input/output (I/O) component(s) 14, and power supply 16. It  
20 should be noted that although some components depicted in FIG. 1 are shown in the singular, they may be plural. For example, computing device 2 might include multiple processors and/or multiple radios. It should also be noted that additional or alternative components may be provided with computing device 2, and the configuration shown in FIG. 1 is merely exemplary.

Memory 4 may take the form of the memory components described herein.  
25 Thus, further elaboration will not be provided, but it should be noted that memory 4 may include any type of tangible medium that is capable of storing information, such as a database. A database may include any collection of records, data, and/or other information. In one embodiment, memory 4 may include a set of embodied computer-executable  
30 instructions that, when executed, facilitate various functions or steps disclosed herein. These embodied instructions will be referred to as “instructions” or an “application” for short.

Processor 6 may actually be multiple processors that receive instructions and process them accordingly. Presentation component 8 may include a display, a speaker,

and/or other components that can present information through visual, auditory, and/or other tactile cues (e.g., a display, a screen, a lamp, a light-emitting diode (LED), a graphical user interface (GUI), or even a lighted keyboard).

Radio 10 may facilitate communication with a network, and may additionally  
5 or alternatively facilitate other types of wireless communications, such as Wi-Fi, WiMAX, LTE, Bluetooth, and/or other VoIP communications. The radio 10 may be configured to support multiple technologies, and/or multiple radios may be configured and utilized to support multiple technologies.

Input/output (I/O) ports 12 may take a variety of forms. Exemplary I/O ports  
10 may include a USB jack, a stereo jack, an infrared port, a firewire port, and/or other proprietary communications ports. Input/output (I/O) components 14 may comprise one or more keyboards, microphones, speakers, touchscreens, and/or any other item usable to directly or indirectly input/output data to or from the computing device 2.

Power supply 16 may include batteries, fuel cells, and/or any other component  
15 that may act as a power source to supply power to computing device 2 or to other components, including through one or more electrical connections or couplings. Power supply 16 may be configured to selectively supply power to different components independently and/or concurrently.

Referring to FIGS. 2A-2B, an exemplary head-mounted display 20 is  
20 provided, in accordance with an embodiment of the present technology. The head-mounted display 20 includes a display module 24, a display boom 26, a base 28 coupled to the display boom 26, a power source 30, a communication component 40, and an electronics module 32 mounted on an item of headwear 22. In FIGS. 2A-2B, the headwear 22 is a helmet, although the head-mounted display 20 may be configured for securement to other types of headwear as  
25 well.

The head-mounted display 20 further includes a camera 38 attached to the  
electronics module 32. The electronics module 32 provides a consolidation of one or more components of the head-mounted display 20 (e.g., computer processor(s), memory, position-tracking component(s), communication component(s), etc.). However, it should be noted that  
30 the components associated with the electronics module 32 may also be distributed at other locations about the head-mounted display 20 and communicatively connected to each other as necessary, rather than consolidated as shown in FIGS. 2A-2B.

The display boom 26 includes a first end 44 coupled to the display module 24 and a second end 46 coupled to the base 28. The display module 24 includes at least one display portion 42 and provides a corresponding display characteristic. In one embodiment, the display portion 42 may include a waveguide optic that is at least partially transparent for providing an augmented reality display on which text, images, and/or other objects may be shown interactively with a real-time viewed-environment.

The display module 24 and the display boom 26 are secured to each other with a releasable coupling 48 (non-limiting examples of which are depicted in FIGS. 15A-15B). The releasable coupling 48 includes a first mateable coupling 50 attached to the first end 44 of the display boom 26 and a second mateable coupling 52 attached to the display module 24. The display module 24 may be interchangeable with other display modules each having a separate mateable coupling that is also releasably securable to the first mateable coupling 50 (e.g., by having a similar configuration as the second mateable coupling 52). The other display modules may also provide different corresponding display characteristics than the display module 24.

The second end 46 of the display boom 26 is movably coupled to the base 28 with a movable coupling 56. The display boom 26 also includes first and second movable joints 58, 60 which, in combination, provide articulation of the display module 24 relative to the base 28. The display boom 26 further includes first and second releasable couplings 62, 64 that allow portions of the display boom 26 to be detached, such as to allow modular configuration. It should be noted that the first and second movable joints 58, 60 and the first and second releasable couplings 62, 64 depicted in FIGS. 2A-2B may or may not be used, depending on the desired functionality and configuration of the head-mounted display 20.

The head-mounted display 20 further includes an attachment mechanism 66 configured to attach the components of the head-mounted display 20 (e.g., the electronics module 32, the display boom 26, the power source 30, etc.) to the headwear 22. The attachment mechanism 66 includes rigid coupling elements 68 and a strap 70 which may be used together to secure the various components of the head-mounted display 20 to the headwear 22. As shown in FIG. 2B, each of the rigid coupling elements 68 may include a concave (i.e., recessed) channel 72 for engaging an edge of the headwear 22, and additionally, a tensioning mechanism 74 may be used with one or more of the rigid coupling elements 68 for securing a corresponding rigid coupling element 68 against the headwear 22. The head-mounted display 20 shown in FIGS. 2A-2B also includes a microphone 78 attached

to the display module 24. The microphone 78 may alternatively be positioned on the display boom 26, and may be configured to receive audio input from a user and communicate with one or more computer processors and/or communication components of the head-mounted display 20.

5           Any of the components of the head-mounted display 20 may be communicatively interconnected with each other. To this effect, communication between components may be provided using a wireless connection (e.g., Bluetooth) and/or a wired-connection, such as the wired connection 80 shown in FIGS. 2A-2B, which may extend through any part of the head-mounted display 20 as needed to reach different components.

10          The head-mounted display 20 may also be configured for wireless communication over a network, such as a cellular, Wi-Fi, Bluetooth, and/or satellite network, as well as any other wireless communication modality, using a communication component that is communicatively connected to computer processors associated with the head-mounted display 20. The communication component (e.g., which may include a radio and antenna)

15          may also be configured to provide, in conjunction with a position-tracking component, location-tracking ability for the head-mounted display 20 through signal triangulation, a global positioning system (GPS) signal, or another tracking method. Additionally, each of the components of the head-mounted display 20 requiring power may be connected to the power source 30 through one or more power cables extending through the various parts of the

20          head-mounted display 20.

            Referring to FIG. 2C, the display boom 26 of the head-mounted display 20 shown in FIGS. 2A-2B is provided in multiple positions, in accordance with an embodiment of the present technology. In FIG. 2C, the display boom 26 is moved from a first position 82 to a second position 84. The first position 82 may be considered a viewing position, at which

25          the display module 24 is at least partially in front of a user's face, and the second position 84 may be considered a retracted position, at which the display module 24 is away from the user's face. At least one of the first and second positions 82, 84 may be user-configurable, and may result in activation, deactivation, and/or changed operation of one or more components of the head-mounted display 20.

30          In this respect, the head-mounted display 20 may be configured such that components and functions thereof can change depending on whether the display boom 26 is in the first position 82 or the second position 84. For example, when the display boom 26 is in the first position 82, the display module 24, including any components thereof (e.g.,

microphone, eye-tracking camera, display, etc.), may have full operation, and when the display boom 26 is in the second position 84, the display module 24 and any components thereof may be at least partially adjusted in operation (e.g., put into sleep mode to save power). Certain components, such as a position-tracking component, may remain in operation regardless of the adjustments to the display boom 26, depending on the configuration.

Referring to FIGS. 3A-3B, first and second movable couplings 86, 88 usable to attach a display boom, such as the display boom 26 shown in FIGS. 2A-2B, to a base of a head-mounted display, such as the base 28 of the head-mounted display 20 shown in FIGS. 2A-2B, are provided, in accordance with an embodiment of the present technology. The first movable coupling 86 shown in FIG. 3A is a rotatable coupling for providing rotational movement of a corresponding display boom, and the second movable coupling 88 shown in FIG. 3B is a ball-joint-type coupling for providing multi-axis movement of a corresponding display boom relative to a base.

Referring to FIGS. 3C-3D, a partial, cross-section view of an exemplary releasable coupling 90 for a display boom of a head-mounted display, such as the display boom 26 of the head-mounted display 20 shown in FIGS. 2A-2B, is provided, in accordance with an embodiment of the present technology. In FIG. 3C, the releasable coupling 90 is a mechanical coupling having first and second releasing mechanisms 92, 94 that can be engaged (i.e., depressed) to decouple an engaging mount 96 from a base mount 95 to allow a display boom to be released from a head-mounted display. In this respect, the releasable coupling 90 is configured to move between a first securing position, as shown in FIG. 3C, and a second releasing position, as shown in FIG. 3D.

Referring to FIG. 4A, a cross-section view of a strap 98 for a head-mounted display, such as the head-mounted display 20 shown in FIGS. 2A-2B, is provided, in accordance with an embodiment of the present technology. The strap 98, of which only a portion is depicted in FIG. 4A, may be rigid, semi-rigid, non-rigid, and/or may include an elastic resilience. In some embodiments, the strap 98 may be permanently fixed to headwear, such as a helmet or hat. To this end, the strap 98 may function as more of a track for providing contacts for communication between various components, as will be described. The strap 98 can include a cable 102, which may be a power and/or communications cable, extending through a channel 104 within the strap 98. The strap 98 can also include a plurality of communication cables 106 exposed on an outer surface of the strap 98. The

communication cables 106 may be configured to mateably attach to a corresponding plurality of communication contacts 108, as shown in FIG. 4B. It is contemplated that in some other embodiments, instead of a cable and channel, the strap 98 itself may include integrated conductive lines having at least partially exposed, conductive surfaces that can provide similar communicative transmission to a cable.

Referring to FIG. 4B, a partial, cross-section view of a component 100 of a head-mounted display, such as the head-mounted display 20 shown in FIGS. 2A-2B, is provided, in accordance with an embodiment of the present technology. The component 100 includes the corresponding plurality of communication contacts 108 configured to be mateably connected to the plurality of communication cables 106 located on the outer surface of the strap 98. Due to the extending and circumscribing nature of the plurality of communication cables 106 on the outer surface of the strap 98, the component 100, which may be, for example, the electronics module 32 depicted in FIGS. 2A-2B, may be secured to the strap 98 at a number of different locations while still maintaining a communicative connection. This flexibility in positioning the component 100 may more easily allow weight distribution of an associated head-mounted display to be accomplished.

Referring to FIGS. 5A-5C, a variety of exemplary tensioning mechanisms 110, 112, 114 that may be used to attach components of a head-mounted display to an item of headwear are provided, in accordance with an embodiment of the present technology. FIG. 5A depicts an exemplary spring-based tensioning mechanism 110, which includes a movable element 116, a fixed element 118, a plunger 122, and a spring 120 that biases the movable element 116 and the fixed element 118 away from each other, controlling a size of a channel 124 formed in the spring-based tensioning mechanism 110, allowing for engagement with an item of headwear.

FIG. 5B depicts a screw-based tensioning mechanism 112 that includes a movable element 126, a fixed element 128, and a screw 130. A channel 132 is formed between the movable element 126 and the fixed element 128, and the screw 130 may be used to bias the movable element 126 towards the fixed element 128 to change the size of the channel 132 to provide a force against an edge of an item of headwear positioned in the channel 132, allowing the tensioning mechanism to be secured to the item of headwear.

FIG. 5C depicts an elastically deformable tensioning mechanism 114 that includes an elastically deformable element 115, which may be formed from any material that provides an elastic resistance when biased (e.g., flexible plastic, rubber, etc.). The elastically

deformable tensioning mechanism 114 may be pulled open to engage an edge of an item of headwear, and then released to provide a force against the edge of the item of headwear to attach the elastically deformable tensioning mechanism 114 to the same. It should be noted that the tensioning mechanisms 110, 112, 114 shown in FIGS. 5A-5C are merely exemplary, and other tensioning mechanisms, including those with different attachment configurations (e.g., magnetic, adhesive, buttons, hook-and-loop fasteners, harnesses, etc.) are possible and contemplated in addition to the examples provided herein.

Referring to FIGS. 6A-6B, a partial, cross-section view of a releasable coupling 134 for a display boom of a head-mounted display, such as the display boom 26 of the head-mounted display 20 shown in FIGS. 2A-2B, is provided, in accordance with an embodiment of the present technology. The releasable coupling 134 shown in FIGS. 6A-6B is a mechanical coupling, the components of which are movable between a first securing position 136, as shown in FIG. 6A, and a second releasing position 138, as shown in FIG. 6B. Movement between the first and second positions 136, 138 occurs through engagement of first and second releasing mechanisms 140, 142, which, when engaged as shown in FIG. 6B, decouple an engaging mount 144 of the releasable coupling 134 from a base mount 146. It should be noted that the releasing mechanism 134 depicted in FIGS. 6A-6B is exemplary, and other configurations (e.g., having mechanical couplings, magnetic couplings, male-female couplings, etc.) are possible and contemplated herein.

Referring to FIGS. 7A-7B, an exemplary strap-based tensioning mechanism 148 for a head-mounted display, such as the head-mounted display 20 shown in FIGS. 2A-2B, is provided, in accordance with an embodiment of the present technology. The strap-based tensioning mechanism 148 may be used to tighten or secure a strap, such as the strap 70 shown in FIGS. 2A-2B, against an item of headwear, such as a helmet. The strap-based tensioning mechanism 148 may be configured to move between a first configuration 150 providing a first strap circumference, as shown in FIG. 7A, and a second configuration 152 providing a second strap circumference, as shown in FIG. 7B, the second circumference being smaller than the first circumference for tightening against the associated item of headwear.

Referring to FIGS. 8A-8B, another exemplary head-mounted display 154 is provided, in accordance with an embodiment of the present technology. The head-mounted display 154 shown in FIGS. 8A-8B is mounted on the item of headwear 22 that is also depicted in FIGS. 2A-2B, and includes a display module 156, a display boom 158, a power

source 162, a camera 164, and an electronics module 166. The electronics module 166 may include a computer processor, a communication component, a position-tracking component, and/or other integrated system components in a consolidated configuration. It should also be noted that, in different configurations, the components associated with the electronics module  
5 166 may be distributed about the head mounted display 154, rather than consolidated, as shown in FIGS. 8A-8B.

A communication cable 174 is provided that extends from the electronics module 166, through the display boom 158, and to the display module 156, to provide communication between the display module 156 and the one or more computer processors  
10 located within the electronics module 166. The head-mounted display 154 also includes an attachment mechanism 176 for securing the display boom 158 to the item of headwear 22. The attachment mechanism 176 includes rigid coupling elements 178 that attach to edges of the item of headwear 22, and a strap 180 which, in conjunction with the rigid coupling elements 178, may be used to secure the display boom 158, the electronics module 166, and  
15 the power source 162 to the headwear 22.

As shown in FIGS. 8A-8B, the display boom 158 includes a first end 182 attached to a first rotatable coupling 184 and a second end 190 attached to a second rotatable coupling 192. The first rotatable coupling 184 is mounted on a first rigid coupling element 186 of the attachment mechanism 176 that is secured to a first side 188 of the headwear 22,  
20 and the second rotatable coupling 192 is attached to a second rigid coupling element 194 that is secured to a second side 196 of the headwear 22.

The display module 156 shown in FIGS. 8A-8B is coupled to the display boom 158 between the first end 182 and the second end 190 of the display boom 158. Additionally, the display boom 158 is movable (i.e., rotatable) about the first and second  
25 rotatable couplings 184, 192. This movement allows a user to move the display boom 158 between a first position (shown in FIGS. 8A and 8B) where the display module 156 is positioned in front of a user's face, and a second position, where the display boom 158 and display module 156 are at least partially away from the user's face (e.g., folded up over a brim 198 of the headwear 22).

30 The display boom 158 of the head-mounted display 154 shown in FIGS. 8A-8B further includes a component module 200 attached adjacent to the display module 156. The component module 200 may provide additional components and functionality, such as a forward-facing camera 202 (e.g., standard, infrared, and/or night vision) for capturing images

and/or video, a rearward-facing camera for tracking eye movement of a user (see FIG. 16C for an example), different sensors and detectors (e.g., a temperature sensor, air-quality sensor, radiation sensor, etc.) for detecting environmental conditions, and/or any other components for a particular application.

5 Referring to FIGS. 9A-9B, exemplary first and second display modules 204, 206 alternatively coupled to a display boom 212 are provided, in accordance with embodiments of the present technology. In FIG. 9A, the first exemplary display module 204 is coupled to the display boom 212 with a first movable attachment 208. The first display module 204 depicted in FIG. 9A includes a non-transparent display (e.g., a micro display,  
10 which may comprise at least one of a LCD, LED display, OLED display, DLP display, etc.) that is adjustable relative to the display boom 212, which may be similar to the display boom 158 shown in FIGS. 8A-8B. The first display module 204 further includes a locking mechanism 214, which may be engaged to allow the first display module 204 to rotate relative to the display boom 212 (e.g., by pressing the button 215), and then disengaged to  
15 allow the first display module 204 to remain in a fixed position relative to the display boom 212 (e.g., by releasing the button 215).

In FIG. 9B, the second exemplary display module 206 is coupled to the display boom 212 with a second movable attachment 210. The second display module 206 includes an optic that is transparent, partially transparent, and/or selectively transparent, and  
20 may be configured to provide an augmented reality display in which text, images, and/or other objects are shown in conjunction with a real-time environment viewed by a user through the optic (e.g., the optic may be a waveguide optic). The second movable attachment 210 allows the second display module 206 to move relative to the display boom 212 in a number of different directions. The second display module 206 may be fixed relative to the  
25 display boom 212 using the locking mechanism 214 and button 215, as discussed with respect to FIG. 9A. It should be noted that the locking mechanism 214 may or may not be used, and retaining the position of the first and second display modules 204, 206 relative to the display boom 212 may be provided through frictional resistance from the first and second movable attachments 208, 210.

30 Referring to FIG. 10, another exemplary head-mounted display 216 mounted to an item of headwear 218 is provided, in accordance with an embodiment of the present technology. In FIG. 10, the head-mounted display 216 includes a display module 220, a display boom 222, a power source 224, and an electronics module 226, which may include

one or more computer processors, position-tracking components, communication components, etc., in addition to other possible or alternative components. Components of the electronics module 226 may also be distributed about the head-mounted display 216, rather than consolidated in the electronics module 226 as in FIG. 10. The head-mounted display 5 216 also includes an attachment mechanism 228 having rigid coupling elements 230 and a strap 234, the rigid coupling elements 230 configured to engage edges 232 of the headwear 218, and the strap 234 configured to secure the rigid coupling elements 230 and the components of the head-mounted display 216 circumferentially about the headwear 218.

FIG. 10 depicts a configuration having the display module 220 and the display boom 222 mounted on a front portion of the headwear 218, which in FIG. 10 is a full-brim-type helmet. The display boom 222 is also coupled to the electronics module 226 with a rotatable coupling 227, which allows the display module 220 to be rotated up and down between a first position in front of a user's face (shown in FIG. 10) and a second position that is at least partially away from a user's face. The display module 220 is also positioned at an 15 end of the display boom 222 off to a first side 229, and an additional component module 231 (e.g., which may include forward and/or rearward-facing cameras, sensors, microphones, etc.) is coupled to the display boom 222 and positioned off to a second side 233.

Referring to FIG. 11, an exemplary harness-coupling component 236 for attaching a head-mounted display to an item of headwear 242 is provided, in accordance with 20 an embodiment of the present technology. The harness-coupling component 236 includes a plurality of receiving-channels 238 which are attachable to a harness-structure 240 of the item of headwear 242. The harness-coupling component 236 is further coupled to a base 244, which may be movably coupled to a display boom 246 (only partially shown), which may be similar to the display boom 26 shown in FIGS. 2A-2B. The harness-coupling component 236 25 may be used in conjunction with other components of an attachment mechanism, such as those of the attachment mechanism 66 shown in FIGS. 2A-2B.

Referring to FIGS. 12A-12B, a partial depiction of an exemplary head-mounted display 248 that includes a sound-dampening ear-cover assembly 250 is provided, in accordance with an embodiment of the present technology. In addition to head-mounted 30 displays and attachment mechanisms for headwear such as helmets, embodiments herein may be configured for use with other protective and/or utility-based equipment, such as eye, ear, face, and/or head protection. In this respect, the head-mounted displays discussed herein may be configured to satisfy various safety standards, such as those outlined in Section 5(a)(1) of

the Occupation Safety and Health Act (“OSHA”), as well as 29 C.F.R. 1910.95 for hearing protection, 29 C.F.R. 1910.135 for head protection, and 29 C.F.R. 1910.33 for eye and face protection, in addition to other standards.

Returning to FIGS. 12A-12B, the sound-dampening ear-cover assembly 250  
5 includes a first portion 256 and a second portion 258 that are movably coupled to each other with a rotatable coupling 254. The sound-dampening ear-cover assembly 250 further includes a lever 260 that can be used to move the sound-dampening ear-cover assembly 250 between a first configuration 262, shown in FIG. 12A, where the first and second portions 256, 258 are in a first position 251 relative to each other, and a second configuration 264, as  
10 shown in FIG. 12B, where the first and second portions 256, 258 are in a second position 253 relative to each other (the positions 251, 253 depicted in FIGS. 12A and 12B are merely exemplary). The lever 260 may be attached to the first portion 256, the second portion 258 (as shown in FIGS. 12A-12B), and/or the rotatable coupling 254, in exemplary embodiments. In the first configuration 262, the second portion 258 is in a relatively lowered position,  
15 where it may abut and/or be compressed against a side of a wearer’s head, such that it substantially encloses a wearer’s ear within the sound-dampening ear-cover assembly 250. In the second configuration 264, the second portion 258 is in a relatively raised position, such that it may be moved away from the wearer’s head (relative to the first configuration 262), to more fully expose a wearer’s ear from within the sound-dampening ear-cover assembly 250.

20 As a result, the head-mounted display 248 depicted in FIGS. 12A-12B provides the option of securing the second portion 258 against or towards a wearer’s head to provide greater sound protection by more fully enclosing the wearer’s ear, and also, moving the second portion 258 away from the wearer’s head with the lever 260 to provide less sound protection by less fully enclosing the wearer’s ear, relatively speaking. In additional  
25 embodiments, latches, clips, straps, and/or other securement components may be used for securing the first and second portions 256, 258 in the first position 251 and/or the second position 253, or in other positions. The head-mounted display 248 shown in FIGS. 12A-12B also includes a mounting portion 272 that extends through the sound-dampening ear-cover assembly 250. The mounting portion 272 may integrally include one or more components of  
30 the head-mounted display 248 (e.g., one or more computer processors and/or communication components) and may provide an attachment point for mounting a display boom, as discussed further with respect to FIGS. 14A-14B.

Referring to FIGS. 13A-13B, a cross-section of the sound-dampening ear-cover assembly 250 depicted in FIGS. 12A-12B is provided, in accordance with an embodiment of the present technology. As shown in FIG. 13A, when the sound-dampening ear-cover assembly 250 is in the first configuration 262, the first and second portions 256, 258 are in the first position 251, with the second portion 258 in a relatively lowered position, allowing it to at least partially surround and/or enclose a wearer's ear 265. As shown in FIG. 13B, when the sound-dampening ear-cover assembly 250 is in the second configuration 264, the first and second portions 256, 258 are in the second position 253, with the second portion 258 at least partially separated, displaced, and/or moved away from the wearer's ear 265 (i.e., angled away relative to the first position 251) to more fully expose the wearer's ear 265 from within the sound-dampening ear-cover assembly 250, thereby providing less sound protection compared to the first configuration 262.

Referring to FIGS. 14A-14B, the head-mounted display 248 depicted in FIGS. 12A-12B is again provided with exemplary display boom attachments, in accordance with embodiments of the present technology. In FIG. 14A, a first display boom 268 is provided, which is secured to the mounting portion 272 of the head-mounted display 248 with a rotatable coupling 270. The first display boom 268 further includes a releasable coupling 274 that allows the first display boom 268 to be secured/released from the rotatable coupling 270 (e.g., for replacement with another type of display boom). The releasable coupling 274 may be similar to the releasable coupling 134 shown in FIGS. 6A-6B.

In FIG. 14B, a second display boom 276 is provided, which is secured to the sound-dampening ear-cover assembly 250. The second display boom 276 is movably coupled to the second portion 258 of the sound-dampening ear-cover assembly 250 with a rotatable coupling 275. The second display boom 276 also includes a releasable coupling 278, which may be similar to the releasable coupling 134 shown in FIGS. 6A-6B, that allows the second display boom 276 to be secured/released from the sound-dampening ear-cover assembly 250. It should be noted that the display booms 268, 276 and mounting configurations thereof shown in FIGS. 14A-14B are merely exemplary, and other configurations and locations are possible and contemplated.

Referring to FIG. 15A, a first releasable coupling 280 for attaching a display module 284 to a display boom 286 of a head-mounted display, such as the head-mounted display 20 shown in FIGS. 2A-2B, is provided, in accordance with an embodiment of the present technology. In FIG. 15A, the first releasable coupling 280 is a mechanical coupling

having a male-female connector 292 and a releasing mechanism 294. The releasable coupling 280 includes a first mateable coupling 288 located at an end of the display boom 286, and a second mateable coupling 290 located on the display module 284. The first and second mateable couplings 288, 290 can be releasably secured to each other to attach the display module 284 to the display boom 286. Additionally, the first releasable coupling 280 may be configured such that a different display module having a separate mateable coupling, which is configured like the second mateable coupling 290 shown in FIG. 15A, may be joined to the first mateable coupling 288 in order to utilize a display module with a different corresponding display characteristic than the display module 284.

10 Referring to FIG. 15B, a second releasable coupling 282 for attaching a display module 285 to a display boom 287 of a head-mounted display, such as the head-mounted display 20 shown in FIGS. 2A-2B, is provided, in accordance with an embodiment of the present technology. In FIG. 15B, the second releasable coupling 282 is magnetic-based and includes a first mateable coupling 296 with a first magnetic polarity and a second mateable coupling 298 with a second magnetic polarity that is opposite to the first magnetic polarity, such that, as a result, the first and second mateable couplings 296, 298 are magnetically attracted to each other. This allows magnetic attachment of the display module 285 to the display boom 287. It should be noted that, as with the first releasable coupling 280 shown in FIG. 15A, the second releasable coupling 282 may be configured such that a different display module having a separate mateable coupling, which is configured like the second mateable coupling 298 shown in FIG. 15B, may be joined to the first mateable coupling 296 in order to utilize a display module with a different corresponding display characteristic than the display module 285.

25 In this regard, it should be noted that exchanging one display module for another display module having a different corresponding display characteristic may result in the computer processor(s) of an associated head-mounted display adapting to the new display characteristic. For example, different display modules having different corresponding display characteristics may each have hardware identifiers and/or embedded metadata that, when detected by a processor of a head-mounted display, such as upon attachment of a display module with a releasable coupling, may cause the processor to load appropriate drivers to reconfigure the visual output to appropriately function with the new display module. As another example, a user might manually load appropriate drivers and/or display configurations for one or more display modules that may be connected to a head-mounted

30

display, or for a currently connected/used display module. Additionally, a processor of a head-mounted display may store, such as in memory, a number of different drivers and/or applications configured to adapt the various functions of the head-mounted display to a display characteristic of an attached display module.

5 Referring to FIGS. 16A-16C, a variety of display modules 300, 302, 304 having different corresponding display characteristics are provided, in accordance with embodiments of the present technology. FIG. 16A depicts a first display module 300 that includes a first display portion 306 coupled to a base 308. The first display portion 306 comprises a first waveguide optic 305 that may be transparent, partially transparent, and/or  
10 selectively transparent (e.g., for providing images, text, and/or other visual elements thereon in an augmented reality display). The base 308 may include a mateable coupling, such as the second mateable coupling 298 shown in FIG. 15B, allowing it to be attached interchangeably to a display boom 310, which may include a corresponding mateable coupling, such as the first mateable coupling 296 shown in FIG. 15B. FIG. 16B depicts a second display module  
15 302 that comprises a second waveguide optic 307 with a circular shape to provide a different field of view than the first waveguide optic 305 shown in FIG. 16A. The second waveguide optic 307 is once again secured to the base 308, which is attached to the display boom 310.

FIG. 16C depicts a third display module 304 that includes a display portion 312 that is non-transparent (e.g., a micro display, which may comprise at least one of a LCD,  
20 LED display, OLED display, DLP display, etc.) for displaying text, images, and/or other objects (e.g., a PDF with black text on white background). The third display module 304 is attached to the display boom 310 and further includes a user-facing camera 314, which may be used to track eye movement of a user wearing the third display module 304 (e.g., for document navigation), and a microphone 316, which may be used for receiving audio input  
25 from a user (e.g., voice commands, communications over a wireless network connection, etc.). It should be noted that any of the head-mounted displays and display modules discussed in this disclosure may include a user-facing camera for tracking eye movement and/or a microphone for receiving audio input, in addition to other components and features.

Referring to FIGS. 17A-17B, an exemplary display module 318 having first  
30 and second display portions 320, 322 is provided, in accordance with an embodiment of the present technology. The first and second display portions 320, 322 are secured to each other, and also, rotatably coupled to a base 324 with a rotatable coupling 326. The base 324 is releasably attached to an end of a display boom 328. The first and second display portions

320, 322 are coupled to each other at an angle, such that the first and second display portions 320, 322 are non-coplanar relative to each other. As a result, when positioned in front of a user's face, the first and second display portions 320, 322 may each remain more angled towards a user's eye than if the first and second display portions 320, 322 were coplanar.

5 The angle of the first and second display portions 320, 322 may be configured based on a user's needs or preference. The first display portion 320 may comprise a micro display and the second display portion 322 may comprise a waveguide optic, allowing multiple visual displays to be provided on the display module 318. In addition, the display module 318 may be activated, deactivated, and/or otherwise have its function modified by rotating the first and

10 second display portions 320, 322 in unison about a common axis 330, as shown in FIG. 17B.

Referring to FIGS. 18A-18B, a display module 332 having first and second display portions 334, 336 is provided, in accordance with an embodiment of the present technology. In FIGS. 18A-18B, the first display portion 334 is non-transparent (e.g., a micro display, which may comprise at least one of a LCD, LED display, OLED display, DLP display, etc.) and the second display portion 336 is transparent, partially transparent, and/or

15 selectively transparent (e.g., a waveguide optic for providing an augmented reality display). The first and second display portions 334, 336 are coupled such that they are coplanar to each other (they may also be at an angle as shown in FIGS. 17A-17B), and also, are attached to a releasable mount 338. The releasable mount 338 allows one or both of the first and second

20 display portions 334, 336 to be independently interchangeable, allowing customization of a display characteristic of the display module 332.

Referring to FIG. 19, a display module 342 having first and second display portions 344, 346 (i.e., a dual-display) is provided, in accordance with an embodiment of the present technology. The first display portion 344 is non-transparent (e.g., a micro display, which may comprise at least one of a LCD, LED display, OLED display, DLP display, etc.)

25 and is shown displaying text for a user to view at one viewing angle, and the second display portion 346 is coupled to the first display portion 344 and is at least partially transparent (e.g., a waveguide optic) and is showing a combination of a user-viewed environment and displayed text/objects 348 at a second viewing angle (i.e., an augmented reality display). The

30 augmented reality display provides an interactive display of information, and may be used in conjunction with audible instructions provided concurrently from one or more computer processors of an associated head-mounted display. In FIG. 19, the second display portion 346 is above the first display portion 344 relative to a user's field of view.

Referring to FIGS. 20A-20B, a display module 350 configured to provide multiple viewing states on a common display portion 352 is provided, in accordance with an embodiment of the present technology. The display module 350 shown in FIGS. 20A-20B is configured to go from a first state 354, as shown in FIG. 20A, that is non-transparent (e.g., providing black text on a white background) to a second state 356, as shown in FIG. 20B, that is at least partially transparent (e.g., an augmented reality display). This configuration allows multiple viewing states (e.g., one for reviewing a document and one for seeing a real-time display of the instructions from the document in the context of the actual environment viewed by the user) to be viewed interchangeably during use of an associated head-mounted display.

Referring to FIG. 21, a block diagram of an exemplary method 2100 of adjusting a head-mounted display is provided, in accordance with an embodiment of the present technology. At a block 2110, a head-mounted display, such as the head-mounted display 20 shown in FIGS. 2A-2B, is provided. The head-mounted display may comprise a display boom, such as the display boom 26 shown in FIGS. 2A-2B, having a first end and a second end, such as the first end 44 and the second end 46 shown in FIGS. 2A-2B, the display boom movably coupled to a base, such as the base 28 shown in FIGS. 2A-2B, located at the second end, one or more computer processors, a power source, a first display module, such as the display module 24 shown in FIGS. 2A-2B, configured to provide multiple viewing states, and a releasable coupling, such as the releasable coupling 48 shown in FIGS. 2A-2B, comprising a first mateable coupling, such as the first mateable coupling 50 shown in FIGS. 2A-2B, and a second mateable coupling, such as the second mateable coupling 52 shown in FIGS. 2A-2B. The first mateable coupling may be located at the first end of the display boom, and the second mateable coupling may be located on the first display module. At a block 1120, the first display module is releasably secured to the display boom by securing the first mateable coupling to the second mateable coupling.

The present technology has been described in relation to particular embodiments, which are intended in all respects to be illustrative rather than restrictive. Alternative embodiments will become apparent to those of ordinary skill in the art to which the present technology pertains without departing from its scope. Different combinations of elements, as well as use of elements not shown, are possible and contemplated.

## CLAIMS

What is claimed is:

1. A head-mounted display having interchangeable components, comprising: a first display module having a first corresponding display characteristic; a display boom comprising a first end and a second end, the display boom movably coupled to a base located at the second end; one or more computer processors communicatively coupled to the first display module; a power source connected to the one or more computer processors; and a releasable coupling comprising a first mateable coupling and a second mateable coupling, the first mateable coupling located at the first end of the display boom and the second mateable coupling located on the first display module, wherein the first and second mateable couplings are releasably securable to each other.
2. The head-mounted display of claim 1, wherein the first mateable coupling is configured to be releasably secured to a separate mateable coupling of a second display module, the second display module having a second corresponding display characteristic that is different than the first corresponding display characteristic.
3. The head-mounted display of claim 1, wherein the releasable coupling comprises at least one of: a magnetic coupling; and a mechanical coupling adjustable between a first securing position and a second releasing position.
4. The head-mounted display of claim 1, wherein the display boom further comprises at least one ball joint for providing articulation of the first display module relative to the base.
5. The head-mounted display of claim 1, wherein the first display module comprises a dual-display providing a first display portion and a second display portion.
6. The head-mounted display of claim 5, wherein the first display portion comprises a micro display and the second display portion comprises a waveguide optic.

7. The head-mounted display of claim 6, wherein the display boom is moveable between a first position and a second position, wherein at least one of the first position and the second position is user-configurable, and wherein at least one of the first and second display portions is deactivated when the display boom is moved from the first position  
5 to the second position.

8. The head-mounted display of claim 6, wherein the waveguide optic is positioned above the micro display on the first display module when the head-mounted display is positioned on a wearer's head.

9. The head-mounted display of claim 6, wherein at least one of the waveguide  
10 optic and the micro display is independently interchangeable on the first display module.

10. A head-mounted display having interchangeable components, comprising: a first display module having a first corresponding display characteristic, the first display module configured to provide multiple viewing states; a display boom comprising a first end and a second end, the display boom movably coupled to a base located at the second end; one  
15 or more computer processors communicatively coupled to the first display module; a power source connected to the one or more computer processors; and a releasable coupling comprising a first mateable coupling and a second mateable coupling, the first mateable coupling located at the first end of the display boom and the second mateable coupling located on the first display module, wherein the first and second mateable couplings are  
20 releasably securable to each other.

11. The head-mounted display of claim 10, wherein the first mateable coupling is configured to be releasably secured to a separate mateable coupling of a second display module, the second display module having a second corresponding display characteristic that is different than the first corresponding display characteristic.

25 12. The head-mounted display of claim 10, wherein the first display module comprises a first display portion and a second display portion, the first display portion comprising a micro display and the second display portion comprising a waveguide optic.

13. The head-mounted display of claim 12, wherein the first display portion and the second display portion are coupled at an angle such that the first and second display portions are non-coplanar.

14. The head-mounted display of claim 10, wherein the releasable coupling  
5 comprises at least one of: a magnetic coupling; and a mechanical coupling movable between a first securing position and a second releasing position.

15. The head-mounted display of claim 10, wherein the first display module provides the multiple viewing states by being adjustable between a first display state and a second display state, the first display state comprising a non-transparent state, and the second  
10 display state comprising a state that is at least partially transparent.

16. A method of adjusting a head-mounted display, the method comprising: providing a head-mounted display comprising: a display boom having a first end and a second end, the display boom movably coupled to a base located at the second end, one or more computer processors, a power source, first display module configured to provide  
15 multiple viewing states, and a releasable coupling comprising a first mateable coupling and a second mateable coupling, the first mateable coupling located at the first end of the display boom the second mateable coupling located on the first display module; and releasably securing the first display module to the display boom by securing the first mateable coupling to the second mateable coupling.

17. The method of claim 16, wherein the multiple viewing states are provided through the first display module being configured with at least one of: a first display portion providing a first display state and a second display portion providing a second display state; and a common display portion providing the first display state and the second display state interchangeably, wherein the first display state comprises a non-transparent state and the  
20 second display state comprises a state that is at least partially transparent.

18. The method of claim 17, further comprising changing between the first display state and the second display state by: rotating the first display portion and the second display portion about a common axis; or changing the common display portion between the first display state and the second display state.

19. The method of claim 17, wherein the second display state comprises an augmented reality display.

20. The method of claim 16, further comprising: decoupling the first and second mateable couplings from each other to decouple the first display module from the display boom; and coupling a separate mateable coupling of a second display module to the first mateable coupling to releasably secure the second display module to the display boom, the first and second display modules comprising different corresponding display characteristics.

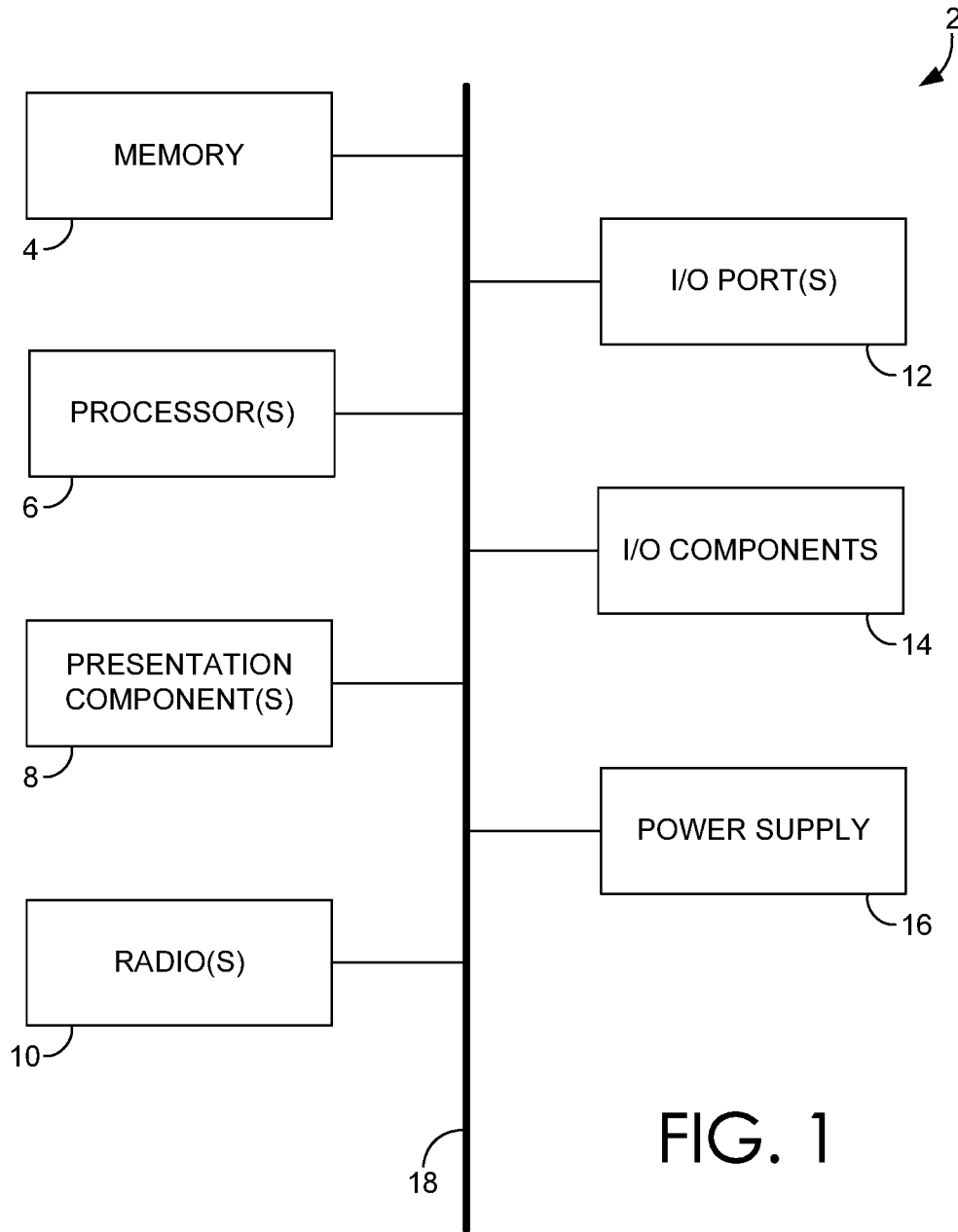

FIG. 1



3/22

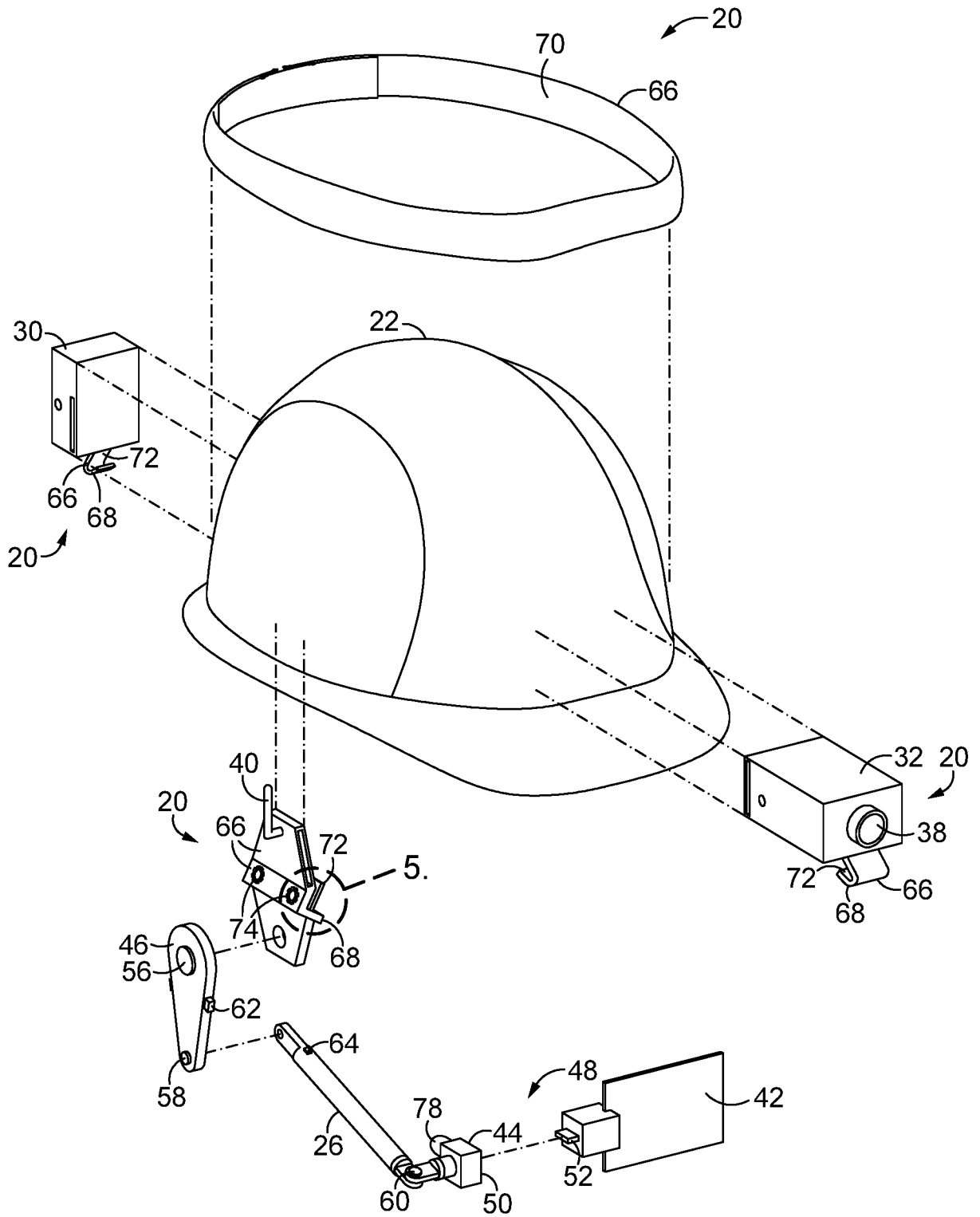

FIG. 2B

4/22

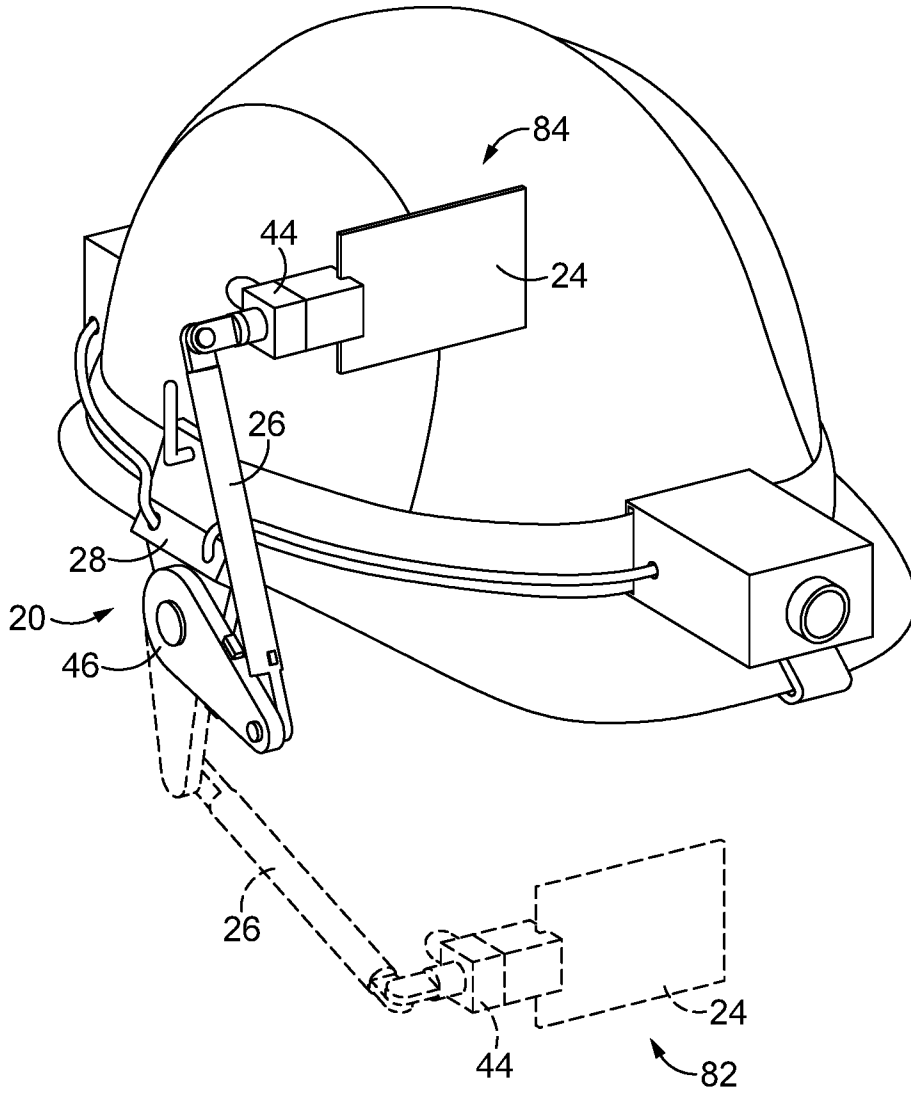

FIG. 2C

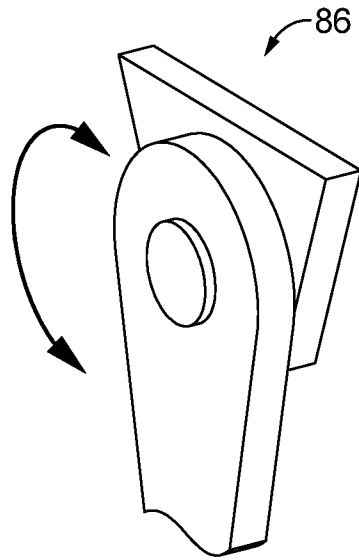

FIG. 3A

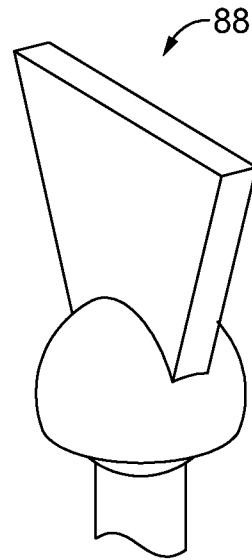

FIG. 3B

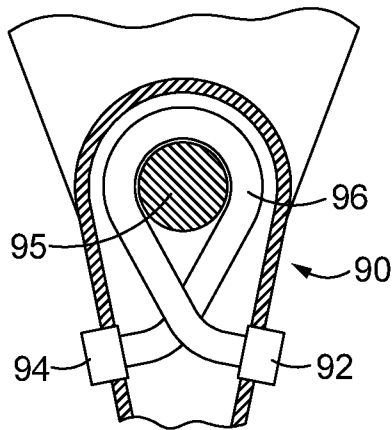

FIG. 3C

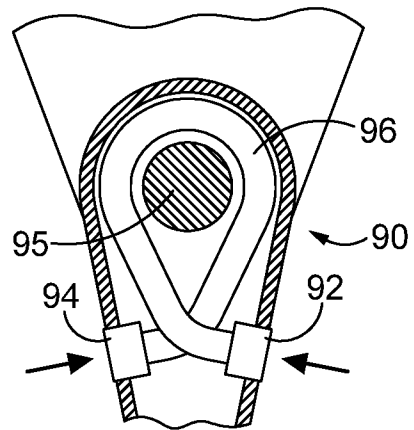

FIG. 3D

6/22

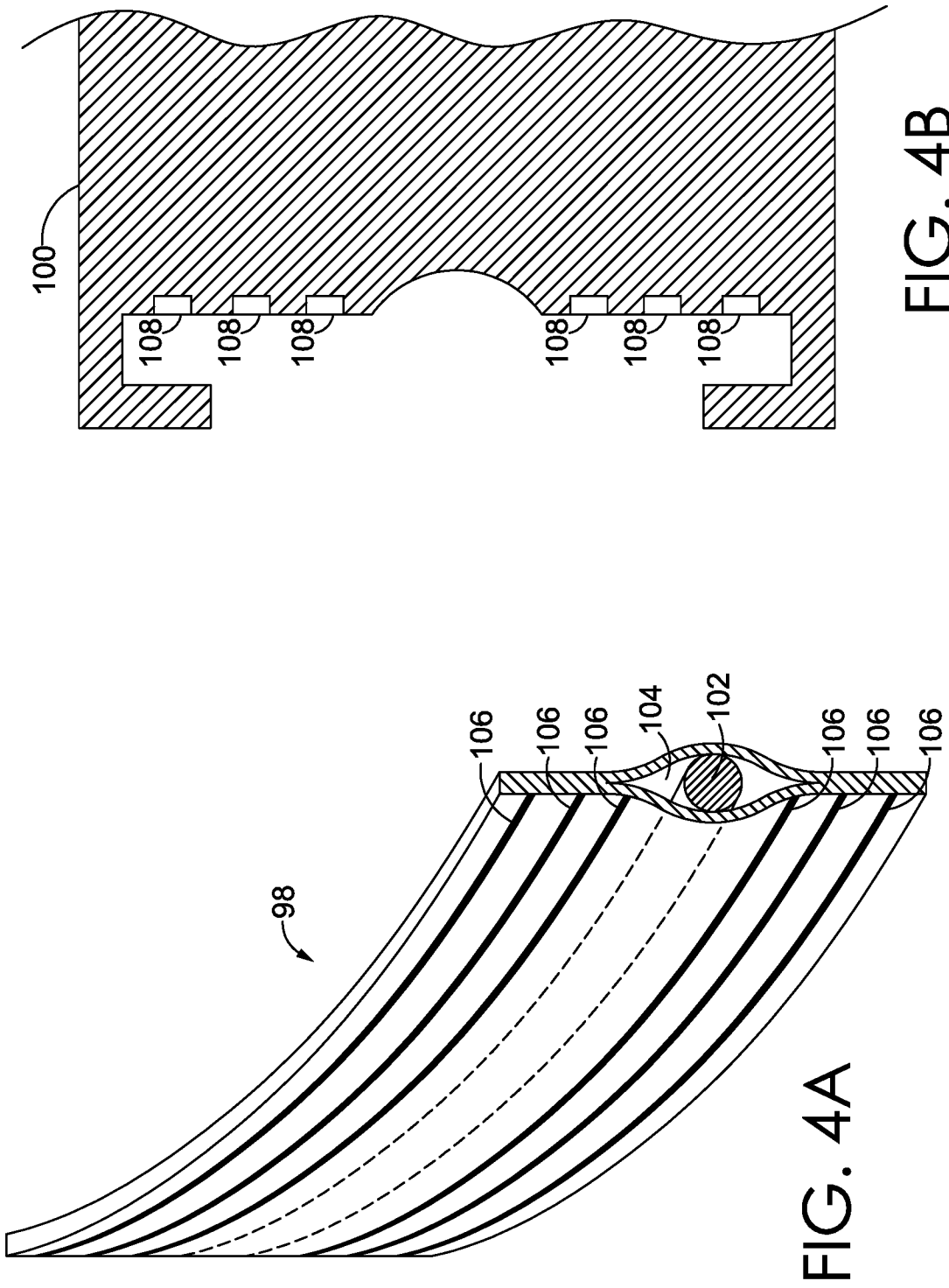

FIG. 4B

FIG. 4A

7/22

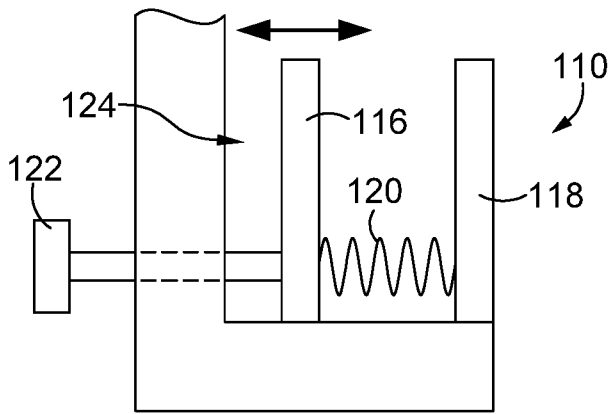

FIG. 5A

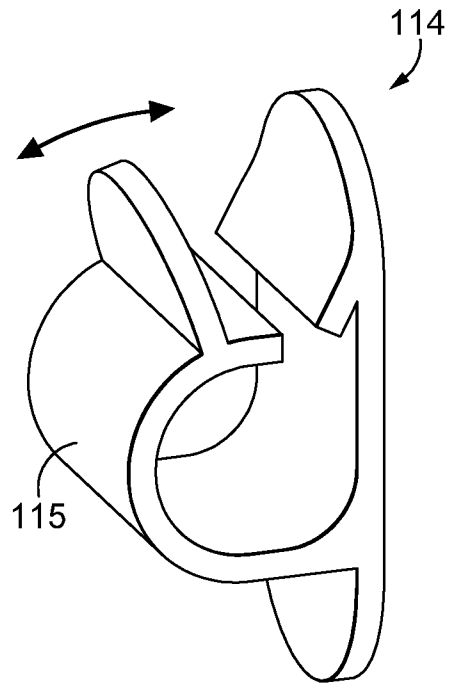

FIG. 5C

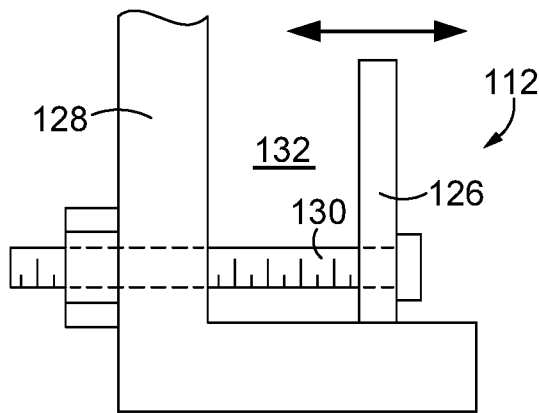

FIG. 5B

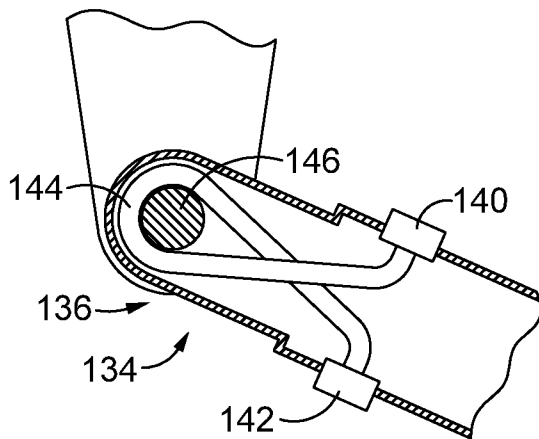

FIG. 6A

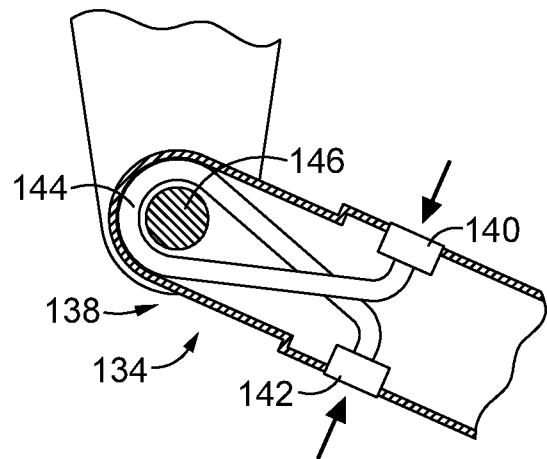
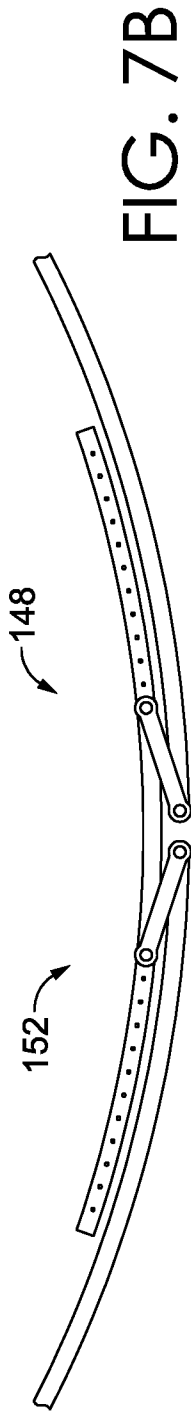
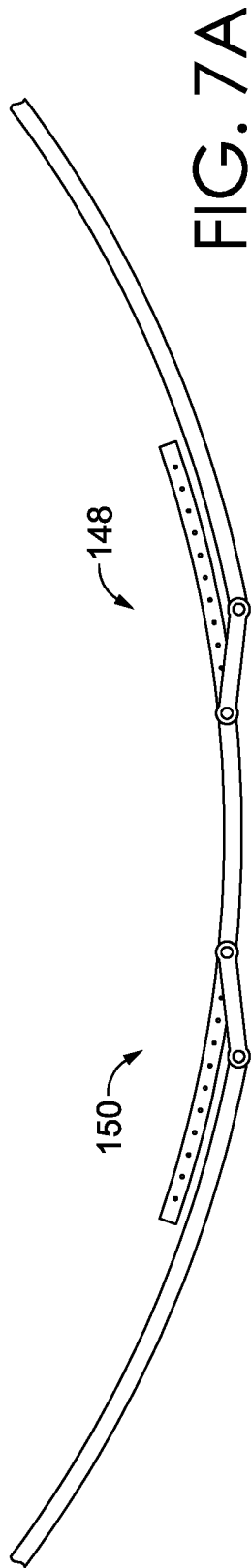

FIG. 6B



9/22

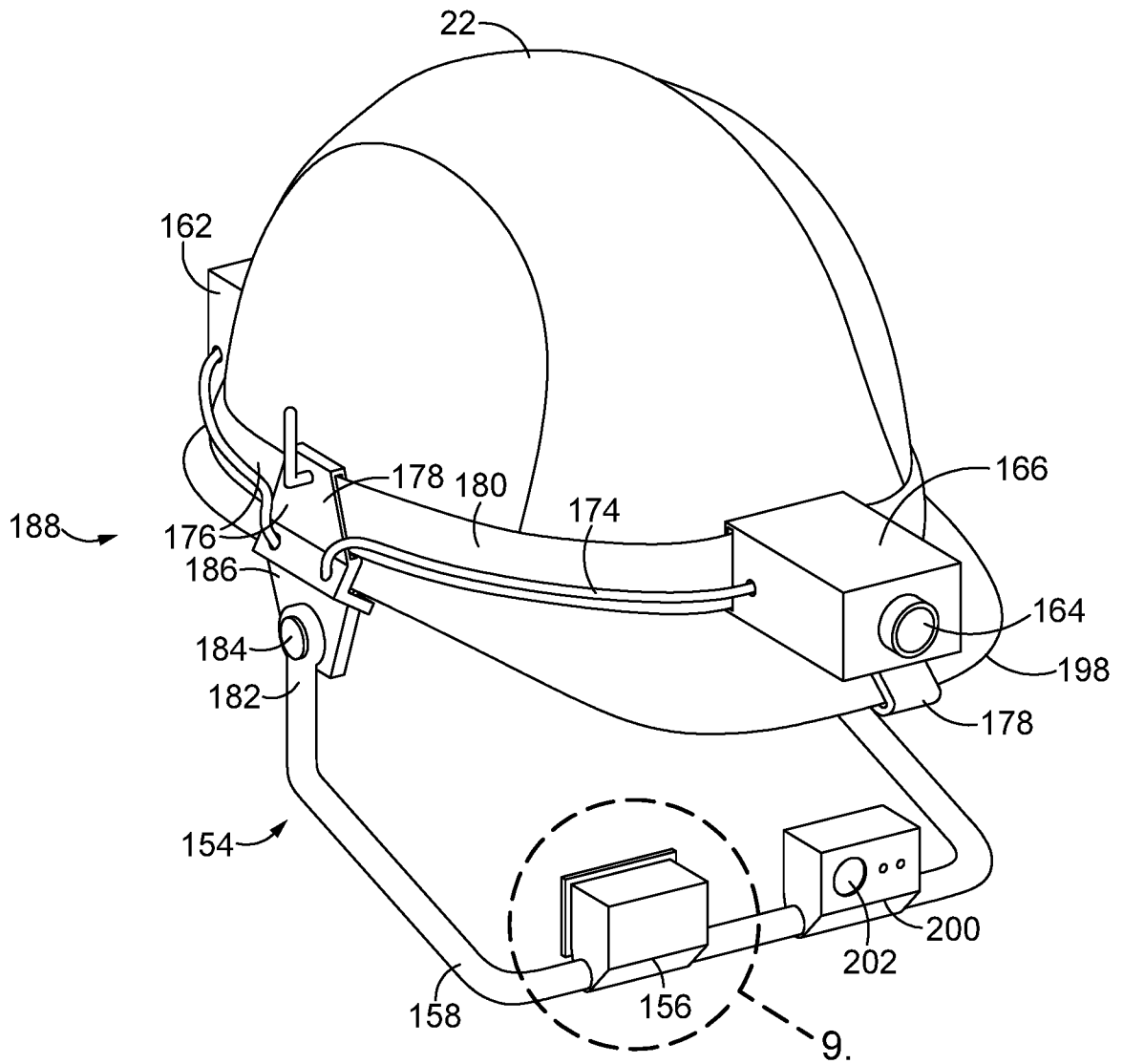

FIG. 8A

10/22

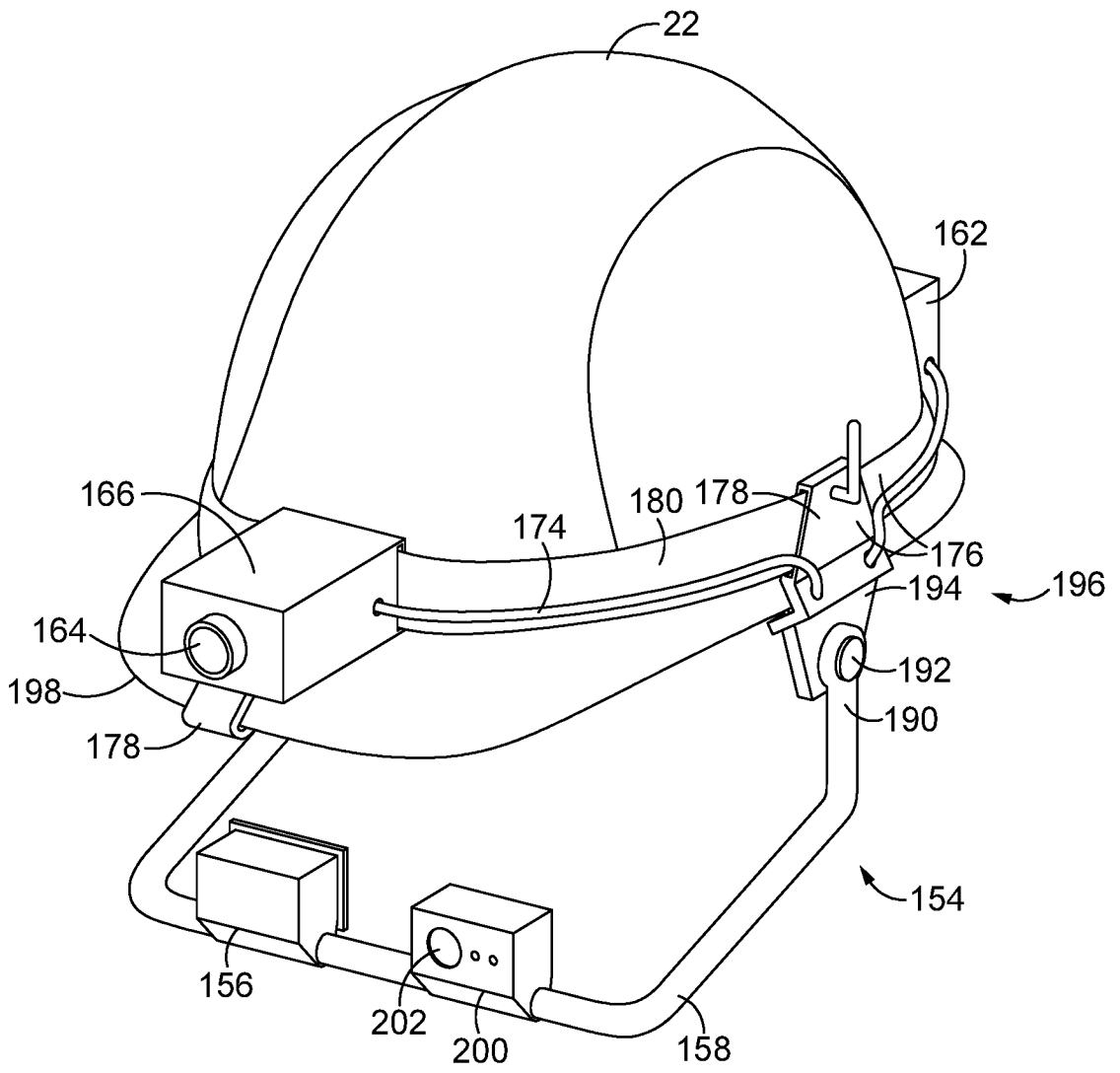

FIG. 8B

11/22

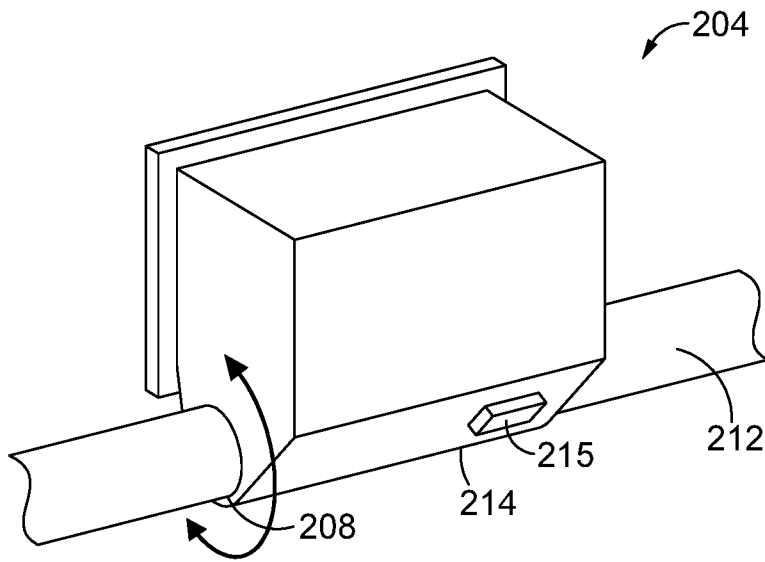

FIG. 9A

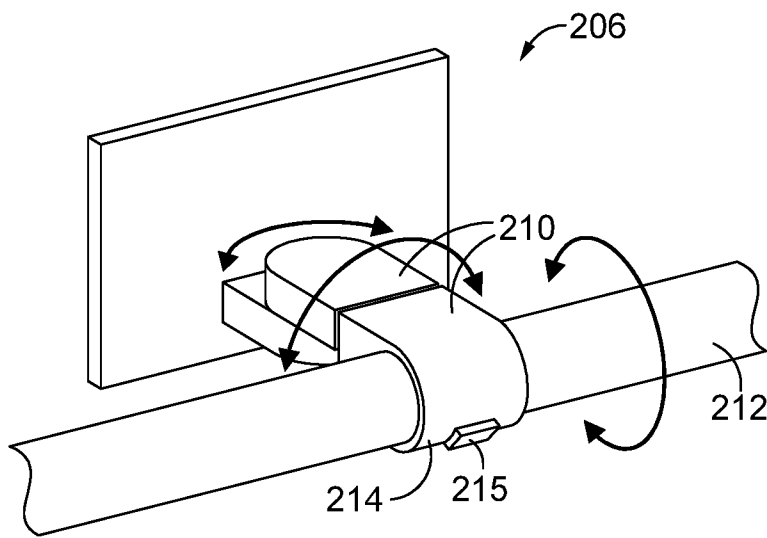
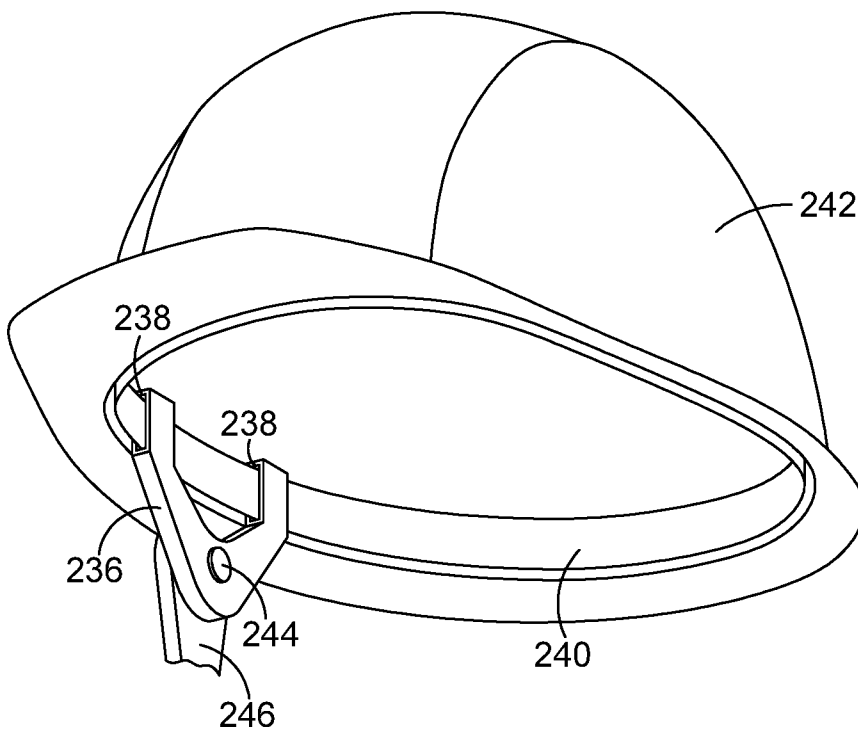
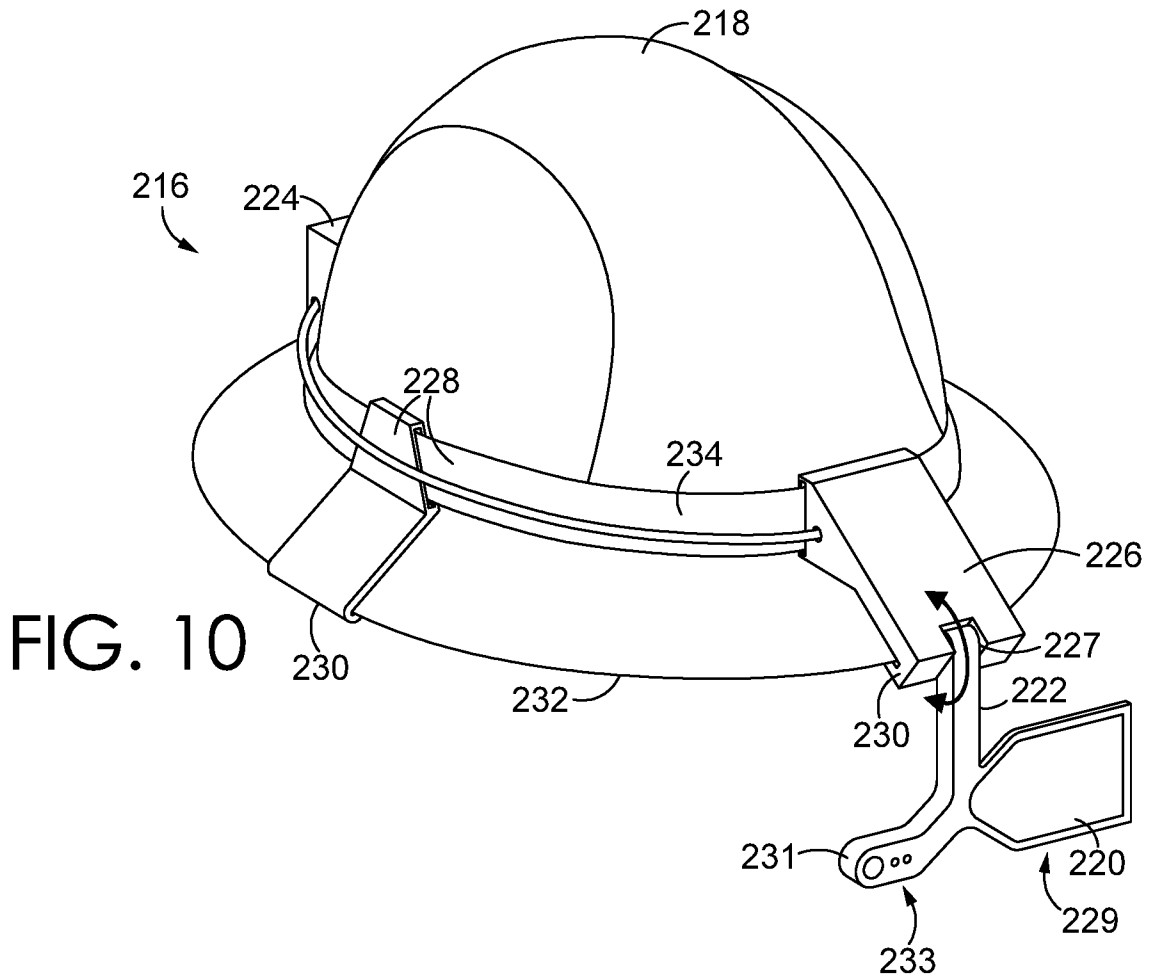
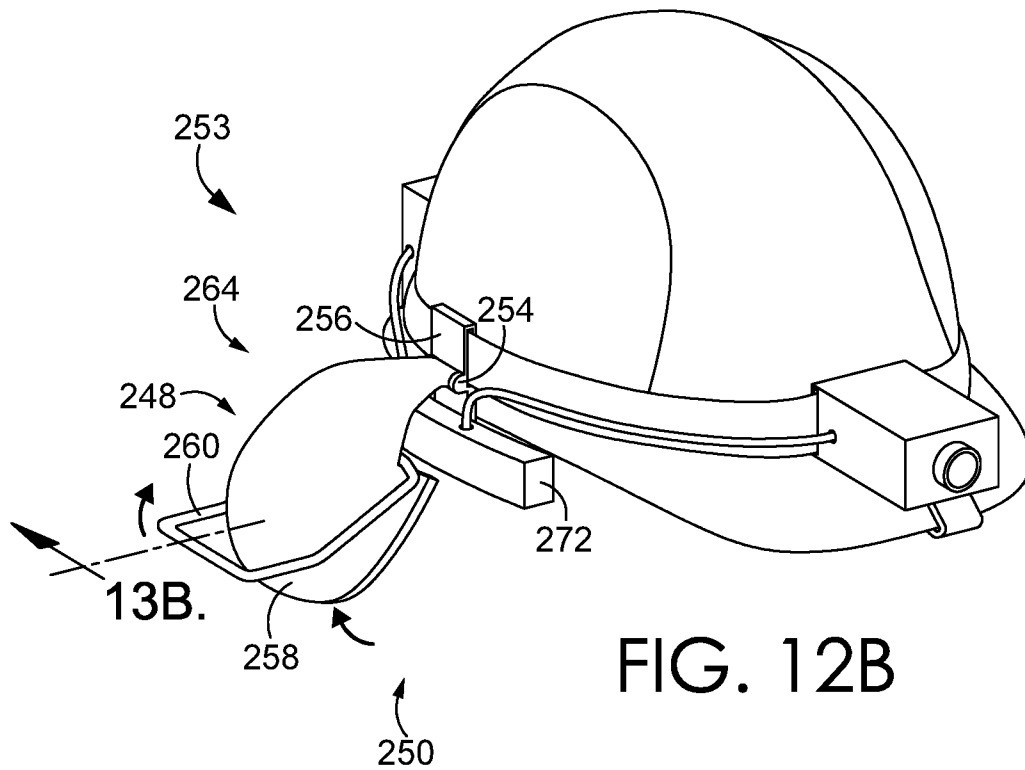
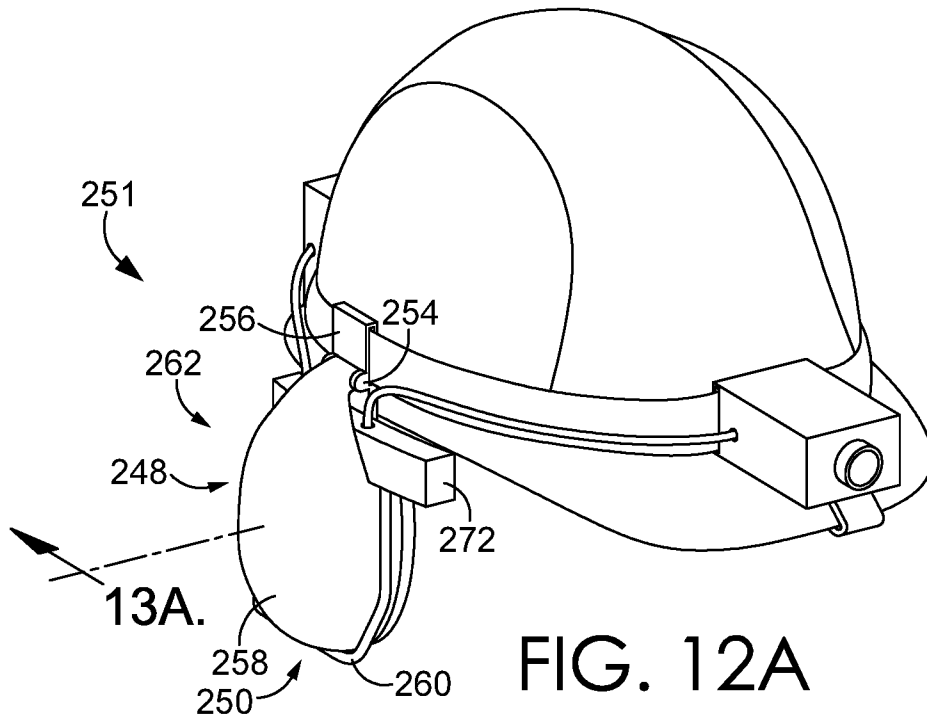

FIG. 9B

12/22





14/22

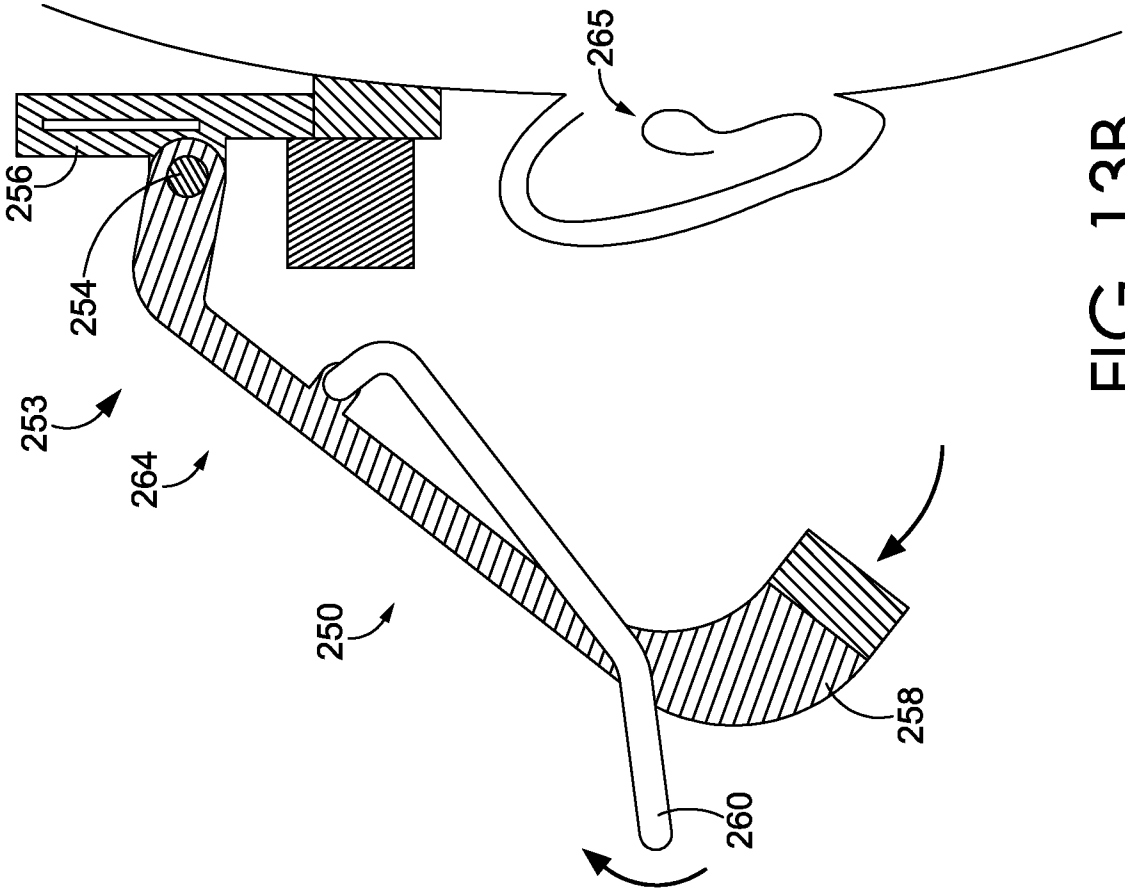

FIG. 13B

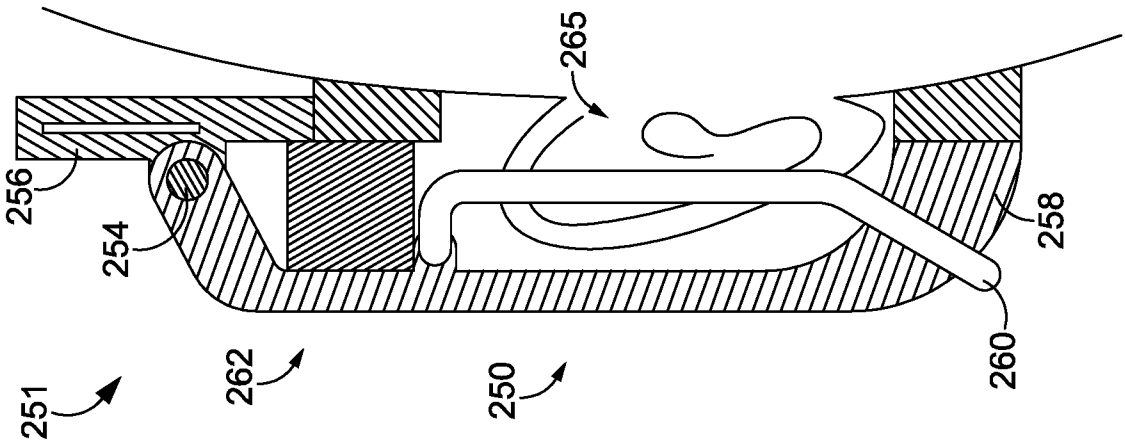

FIG. 13A

15/22

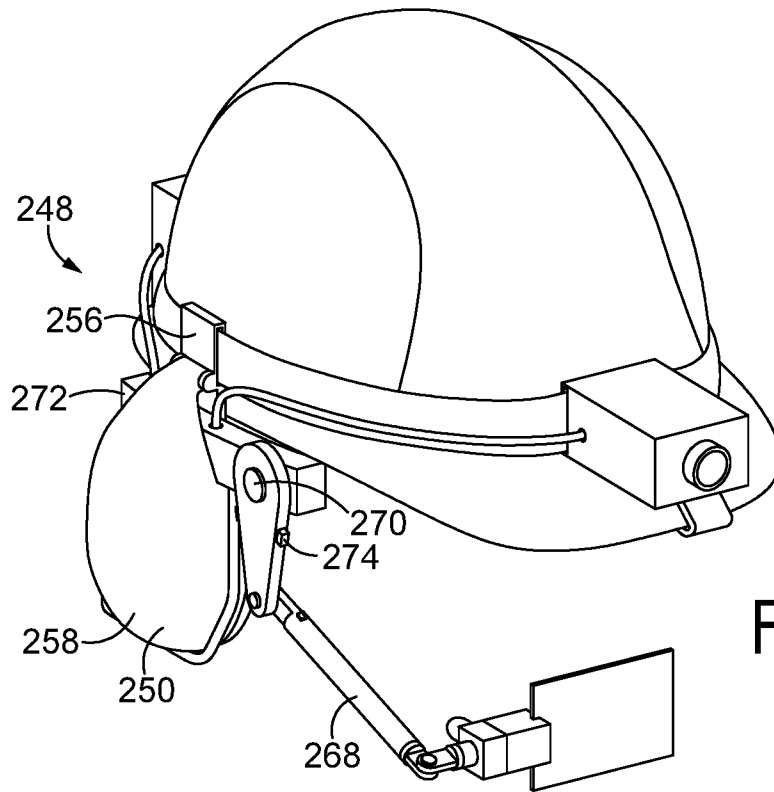

FIG. 14A

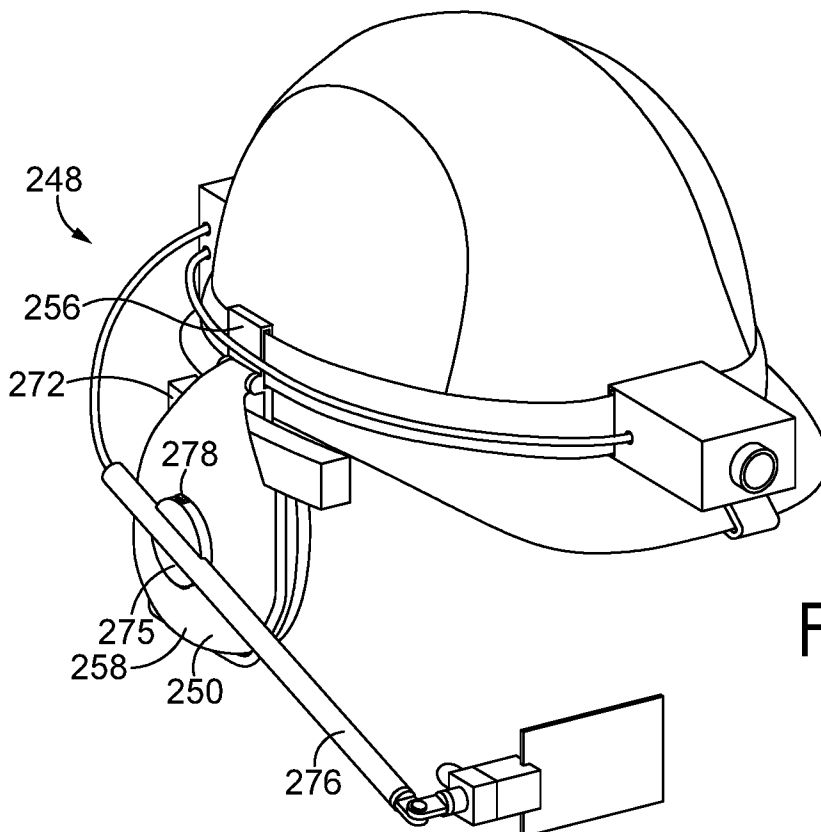

FIG. 14B

16/22

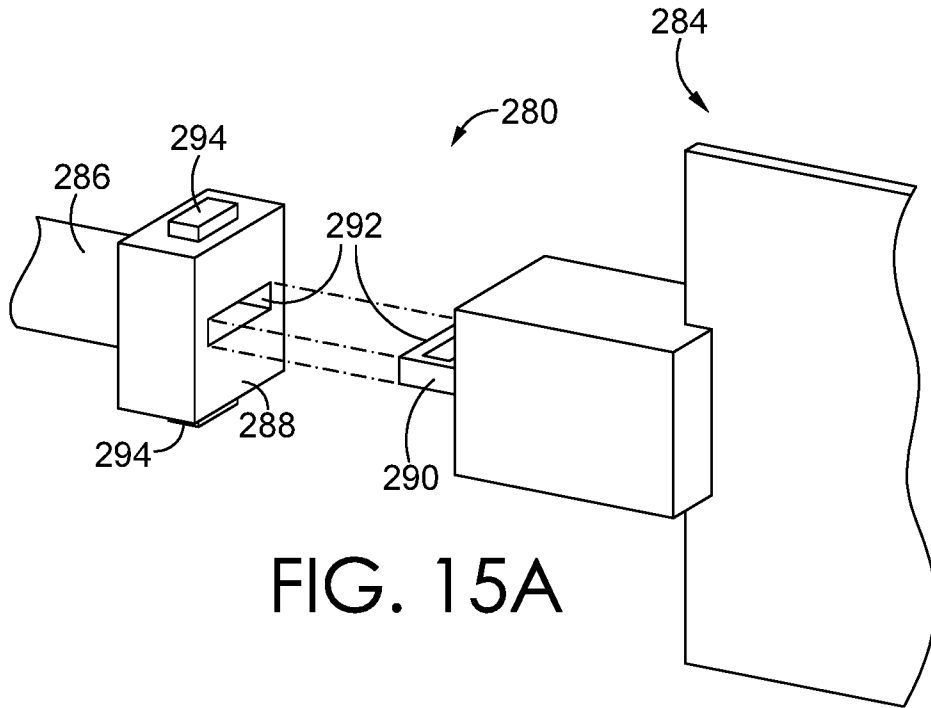

FIG. 15A

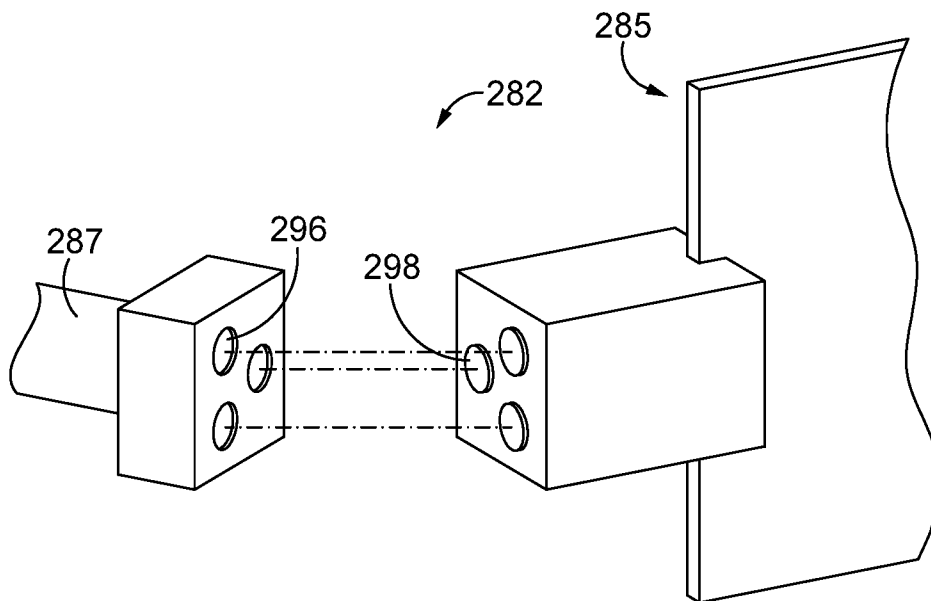
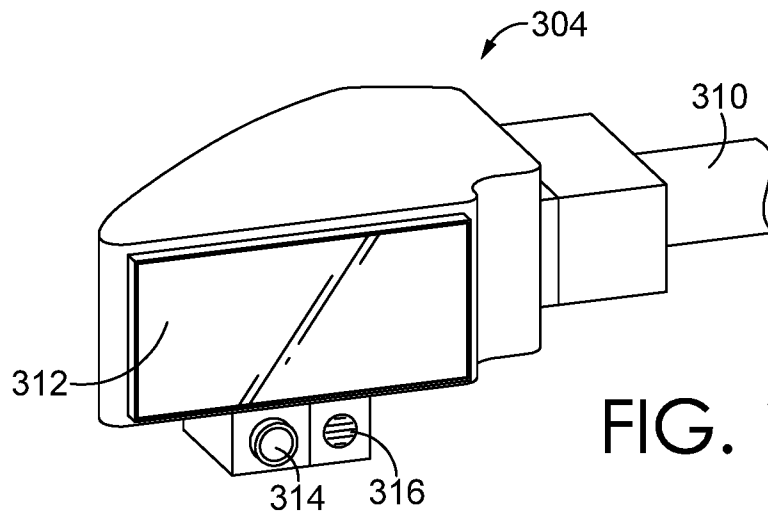
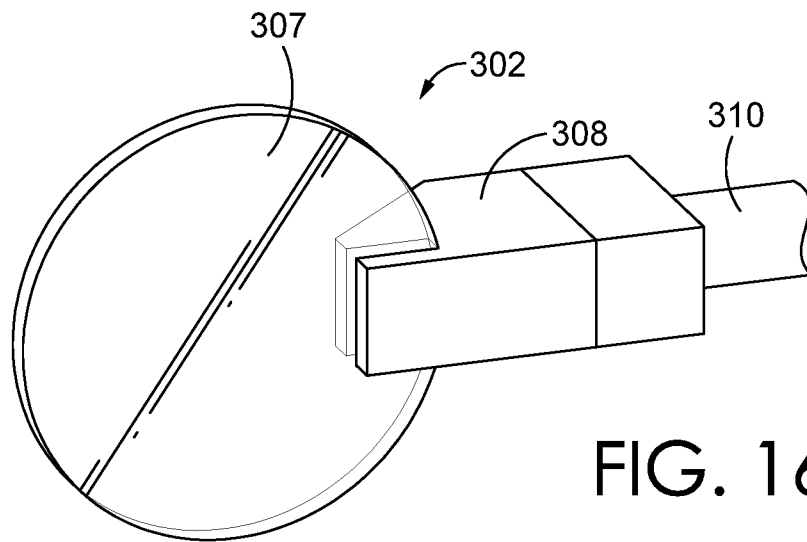
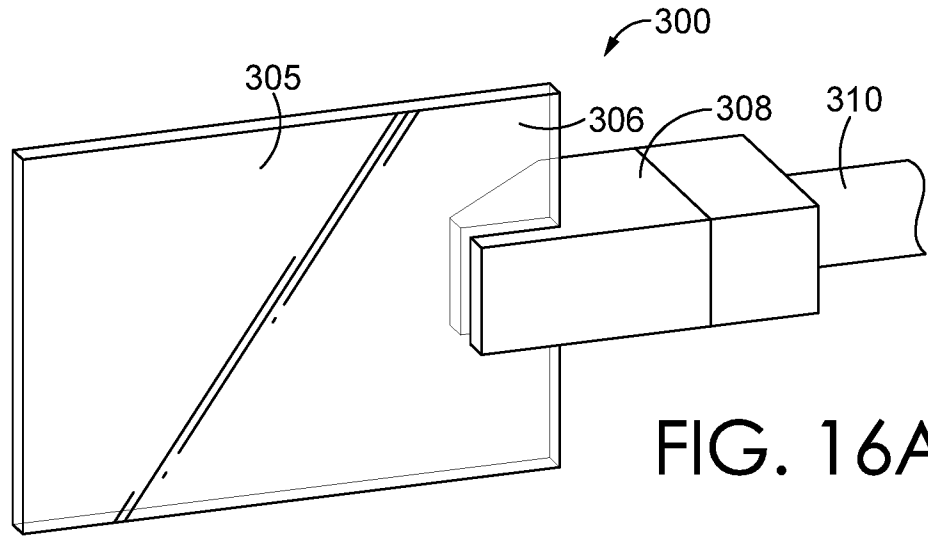
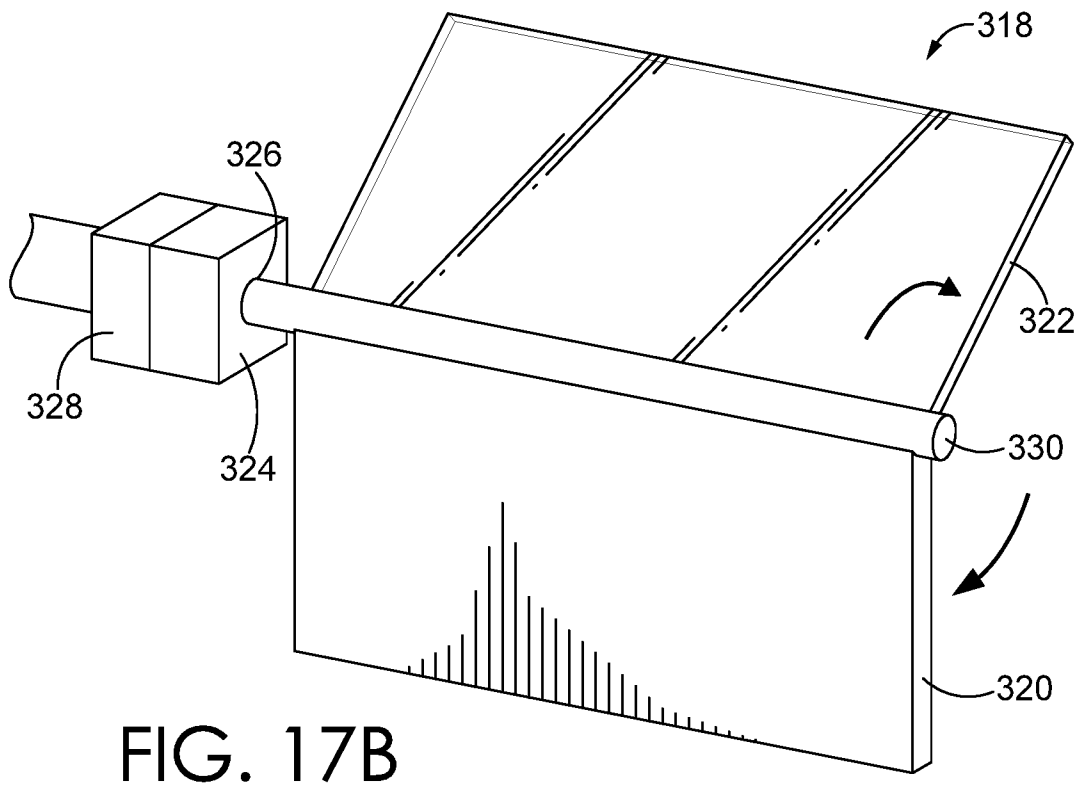
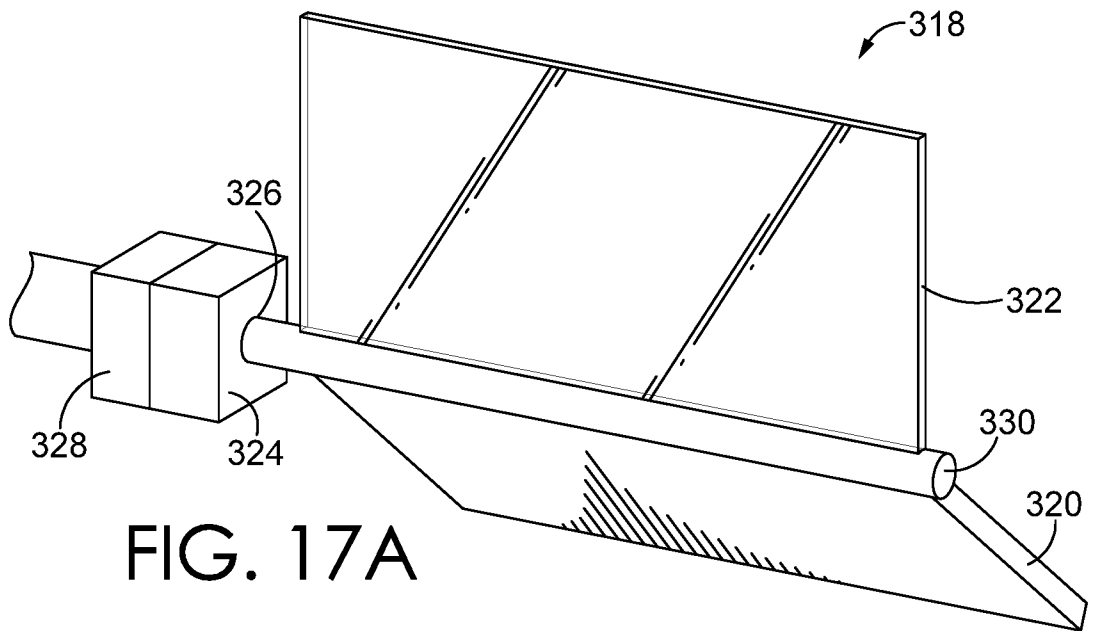

FIG. 15B

17/22



18/22



19/22

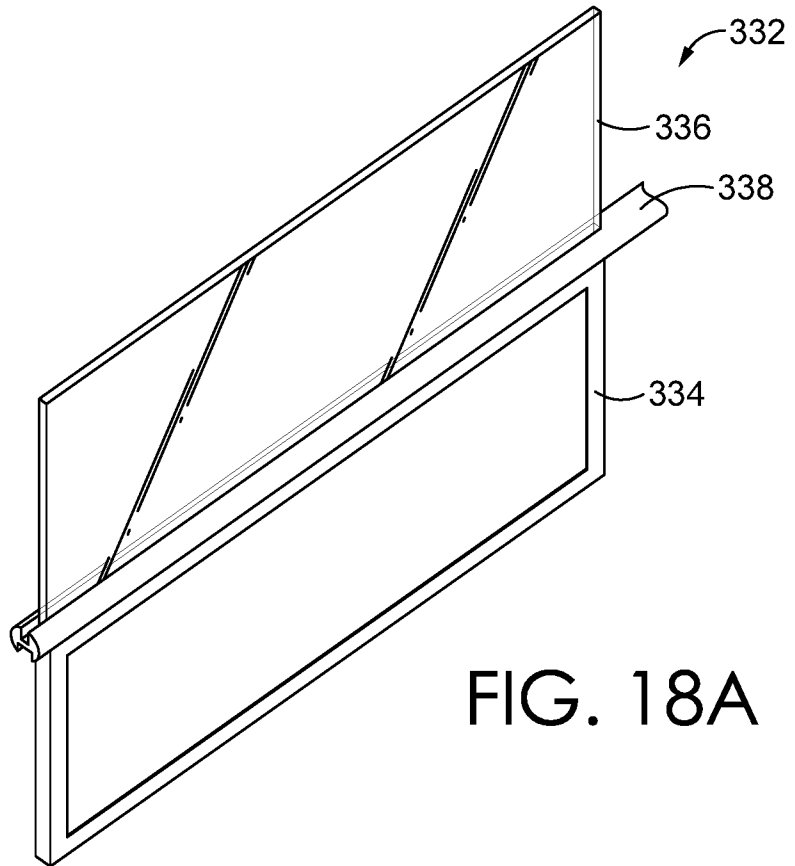

FIG. 18A

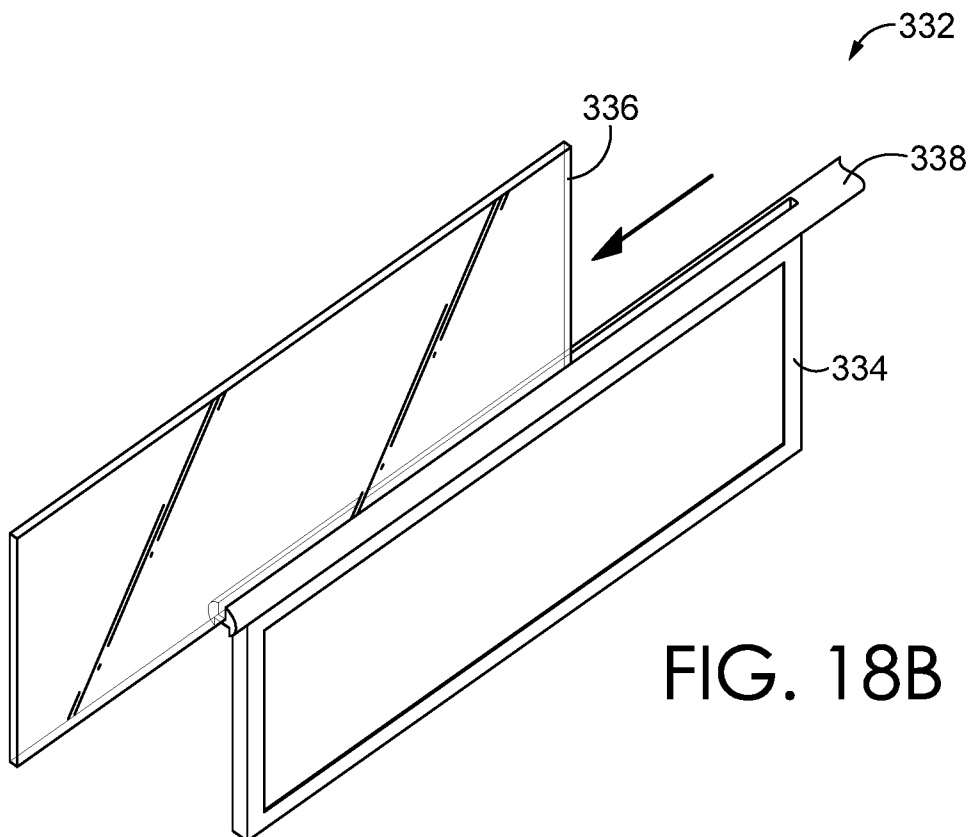

FIG. 18B

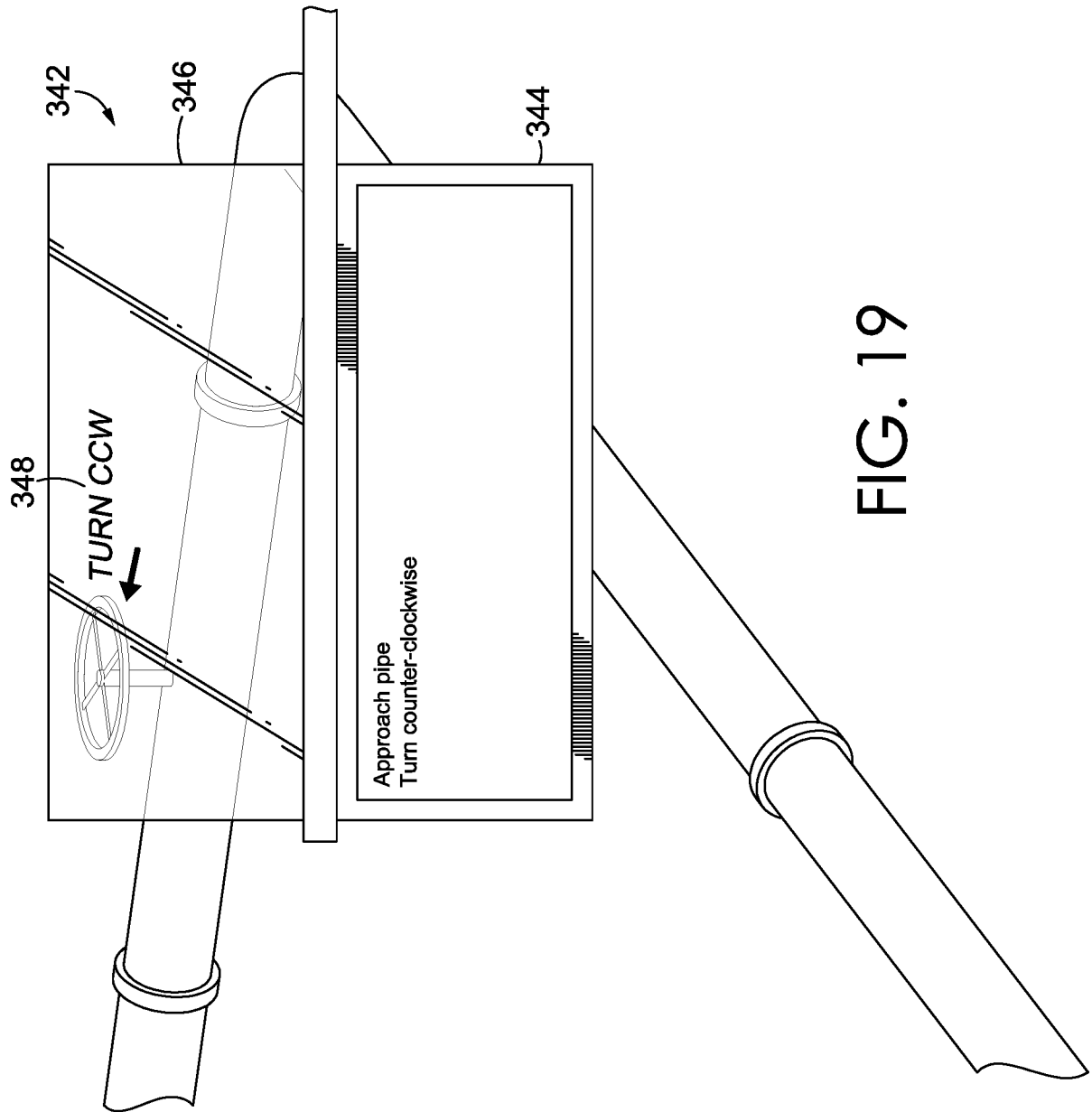

FIG. 19

21/22

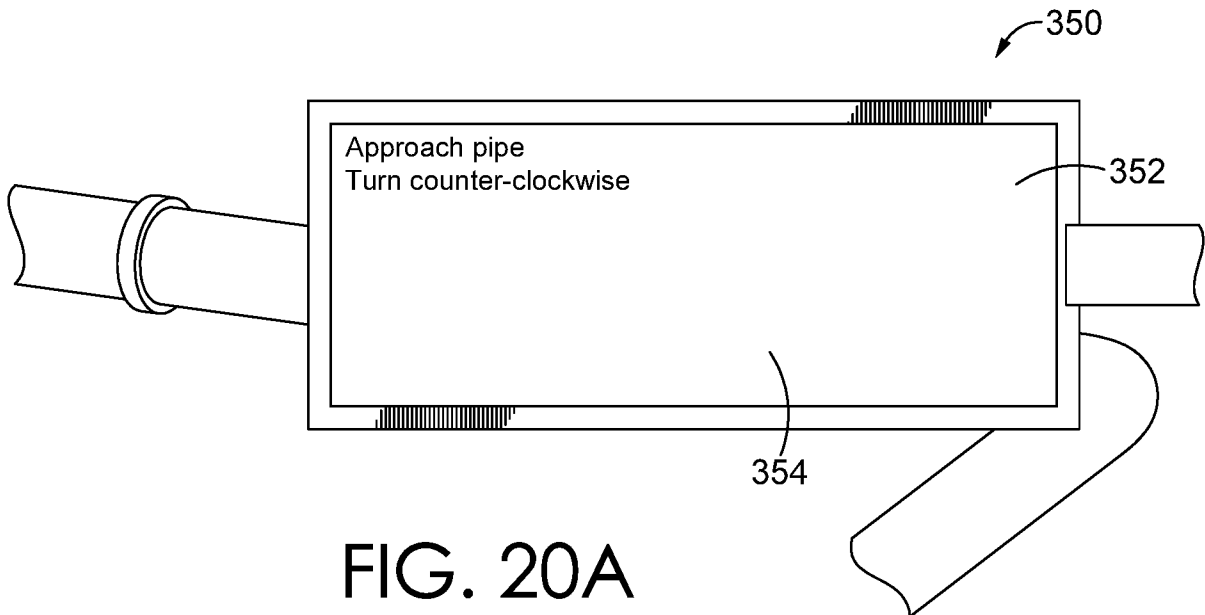

FIG. 20A

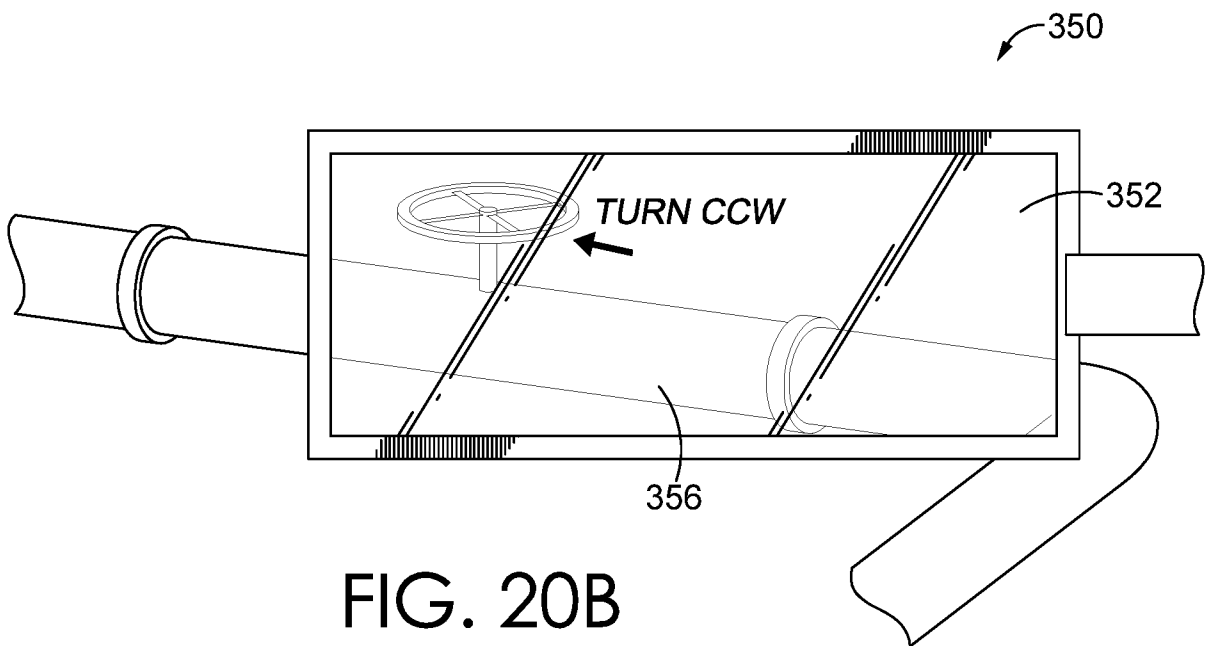

FIG. 20B

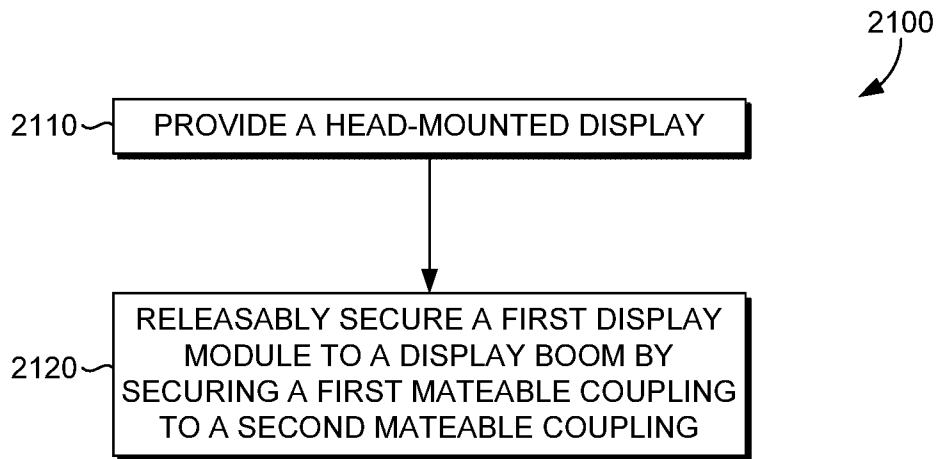

FIG. 21

<b>INTERNATIONAL SEARCH REPORT</b>		International application No. PCT/US17/64898		
<b>A. CLASSIFICATION OF SUBJECT MATTER</b> IPC: <b>G02B 27/01( 2006.01)</b>  CPC: <b>G02B 27/017, 27/0172, 2027/0132, 2027/0187, 27/0176</b> According to International Patent Classification (IPC) or to both national classification and IPC				
<b>B. FIELDS SEARCHED</b>				
Minimum documentation searched (classification system followed by classification symbols) CPC : G02B 27/017, 27/0172, 2027/0132, 2027/0187, 27/0176				
Documentation searched other than minimum documentation to the extent that such documents are included in the fields searched				
Electronic data base consulted during the international search (name of data base and, where practicable, search terms used)				
<b>C. DOCUMENTS CONSIDERED TO BE RELEVANT</b>				
Category *	Citation of document, with indication, where appropriate, of the relevant passages	Relevant to claim No.		
Y	US 2011/0249122 A1 (Tricoukes et al.) 13 October 2011, see entire document.	1-16, 20		
Y	US 2014/0028923 A1 (Griffin et al.) 30 January 2014, see entire document.	1-16, 20		
Y	US 2016/0370855 A1 (Lanier et al.) 22 December 2016, see entire document.	5-9, 12-13, 15		
Y	US 6,587,700 B1 (Meins et al.) 01 July 2003, see entire document.	7		
<input type="checkbox"/> Further documents are listed in the continuation of Box C. <input type="checkbox"/> See patent family annex.				
* Special categories of cited documents: <table style="width: 100%; border: none;"> <tr> <td style="width: 50%; border: none;">               "A" document defining the general state of the art which is not considered to be of particular relevance                "E" earlier application or patent published on or after the international filing date                "L" document which may throw doubts on priority claim(s) or which is cited to establish the publication date of another citation or other special reason (as specified)                "O" document referring to an oral disclosure, use, exhibition or other means                "P" document published prior to the international filing date but later than the priority date claimed             </td> <td style="width: 50%; border: none;">               "T" later document published after the international filing date or priority date and not in conflict with the application but cited to understand the principle or theory underlying the invention                "X" document of particular relevance; the claimed invention cannot be considered novel or cannot be considered to involve an inventive step when the document is taken alone                "Y" document of particular relevance; the claimed invention cannot be considered to involve an inventive step when the document is combined with one or more other such documents, such combination being obvious to a person skilled in the art                "&amp;" document member of the same patent family             </td> </tr> </table>			"A" document defining the general state of the art which is not considered to be of particular relevance "E" earlier application or patent published on or after the international filing date "L" document which may throw doubts on priority claim(s) or which is cited to establish the publication date of another citation or other special reason (as specified) "O" document referring to an oral disclosure, use, exhibition or other means "P" document published prior to the international filing date but later than the priority date claimed	"T" later document published after the international filing date or priority date and not in conflict with the application but cited to understand the principle or theory underlying the invention "X" document of particular relevance; the claimed invention cannot be considered novel or cannot be considered to involve an inventive step when the document is taken alone "Y" document of particular relevance; the claimed invention cannot be considered to involve an inventive step when the document is combined with one or more other such documents, such combination being obvious to a person skilled in the art "&" document member of the same patent family
"A" document defining the general state of the art which is not considered to be of particular relevance "E" earlier application or patent published on or after the international filing date "L" document which may throw doubts on priority claim(s) or which is cited to establish the publication date of another citation or other special reason (as specified) "O" document referring to an oral disclosure, use, exhibition or other means "P" document published prior to the international filing date but later than the priority date claimed	"T" later document published after the international filing date or priority date and not in conflict with the application but cited to understand the principle or theory underlying the invention "X" document of particular relevance; the claimed invention cannot be considered novel or cannot be considered to involve an inventive step when the document is taken alone "Y" document of particular relevance; the claimed invention cannot be considered to involve an inventive step when the document is combined with one or more other such documents, such combination being obvious to a person skilled in the art "&" document member of the same patent family			
Date of the actual completion of the international search 13 January 2018 (13.01.2018)		Date of mailing of the international search report <b>19 JAN 2018</b>		
Name and mailing address of the ISA/US Mail Stop PCT, Attn: ISA/US Commissioner for Patents P.O. Box 1450 Alexandria, Virginia 22313-1450 Facsimile No. (571) 273-8300		Authorized officer Michael Horabik Telephone No. 571-272-4300		