

(No Model.)

J. SEIPEL.

FIREPROOF FLOOR AND CEILING CONSTRUCTION.

No. 522,168.

Patented June 26, 1894.

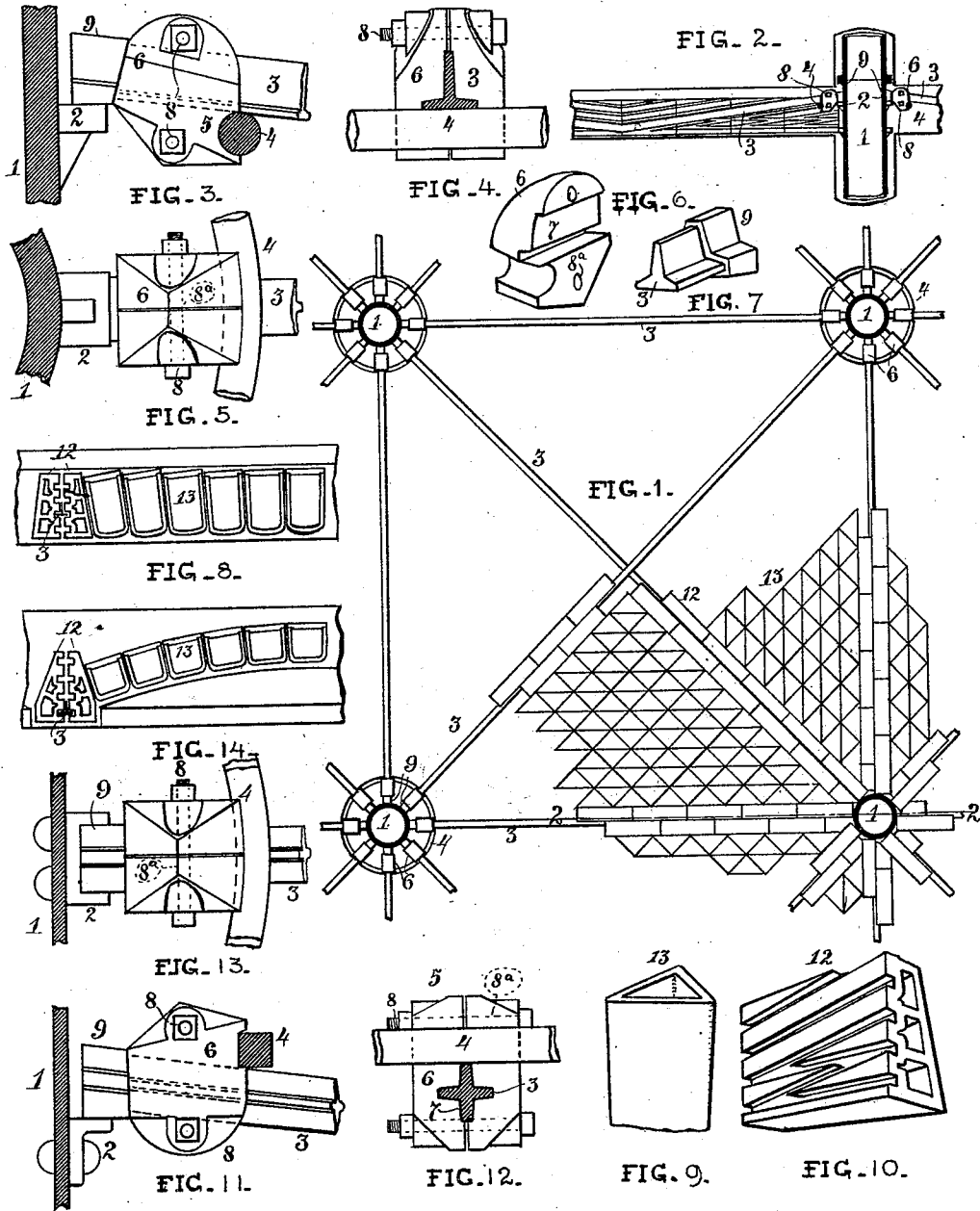

Attest:
A. M. Ebersole
C. E. Edwards.

Inventor:
Jacob Seipel.
 By *Knights Bros.*
Atty.

UNITED STATES PATENT OFFICE.

JACOB SEIPEL, OF ST. LOUIS, MISSOURI.

FIREPROOF FLOOR AND CEILING CONSTRUCTION.

SPECIFICATION forming part of Letters Patent No. 522,168, dated June 26, 1894.

Application filed February 2, 1894. Serial No. 498,875. (No model.)

To all whom it may concern:

Be it known that I, JACOB SEIPEL, of the city of St. Louis, in the State of Missouri, have invented a certain new and useful Improvement in Fireproof Floor and Ceiling Constructions, of which the following is a full, clear, and exact description, reference being had to the accompanying drawings, forming part of this specification.

My invention relates to an improved means of supporting the tension bars upon the supporting columns.

My invention consists in features of novelty hereinafter fully described and pointed out in the claims.

Figure 1 is a top or plan view, illustrative of my invention. Fig. 2 is a transverse section, taken on line 2—2, Fig. 1. Fig. 3 is a side elevation of the wall or column bracket, the tension bar, and clamp device, and a supporting ring being shown in cross section. Fig. 4 is a sectional view of the inverted T bar and its supporting ring, the clamp being shown in elevation. Fig. 5 is an under, perspective view of the bracket, tension bar column, ring and clamping device which form the support. Fig. 6 is a perspective view of the casting, suitably grooved to receive the inverted T bar. Fig. 7 is an enlarged, detail perspective view of the upset end of the inverted T bar. Fig. 8 is a section, showing the construction of the tile flooring. Fig. 9 is a perspective view of the tile block. Fig. 10 is a perspective view of the skewback tile. Fig. 11 is a view, part in section and part in elevation, of a modified form of bar, and also a modified form of wall bracket. Fig. 12 is an enlarged, detail view of a modified form of bar, shown in cross section. Fig. 13 is a top or plan view of the tension bar and its supports. Fig. 14 is a section, showing a modified means of forming an arched tile construction.

1 represents the columns having brackets 2 formed upon or secured thereto at the floor elevations. In Fig. 3 I have shown the bracket formed upon the column, while in Fig. 11 I have shown it secured thereto.

3 represents the tension bars extending from column to column, as indicated in Fig. 1. These bars have enlarged ends 9, as shown

in Figs. 3 and 7, and secured thereto are clamps 6, which are made in two parts secured together upon the bars by bolts 8 passing through holes 8^a in the clamps. The clamps have grooves 7 to receive the bars, the grooves being made of a form to correspond with the sectional shape of the bars. The bars may be of T form in cross section, as shown in Figs. 3, 4 and 7, or they may be in the form of a cross in transverse section, as shown in Figs. 11, 12 and 13, or they may be of other suitable form in transverse section. The heads 9 of the bars 3 prevent the bars from pulling out of the clamps 6.

4 represents rings surrounding the columns and securing the blocks 6 thereto, the blocks having grooves 5 in which the rings 4 fit. The rings 4 serve to keep the blocks 6 from moving in a direction away from the columns, and as the bars 3 cannot move within the clamp 6, in a direction away from the columns, the bars are thus held upon the brackets 2. The rings 4 may be cylindrical in cross section, as shown in Fig. 3, or may be square in cross section, as shown in Fig. 11, or they may be of other desired shape. While the bars 3 cannot move in a direction away from the columns sufficiently far to miss the brackets 2, on account of the heads 9 coming against the clamps 6, still the bars can move to a certain extent within the clamps, the limit of the movement being the difference in distance between the inner faces of the clamps and the columns 1, as compared with the length of the enlargements 9 of the bars. This permits the bars to balance themselves throughout the floor structure, and also permits the use of bars varying slightly in length. After the bars are secured in place, the spaces between them are filled with skew-backs 12 and tiling 13, thus forming a fire-proof structure, which owing to my improved manner of securing the bars to the columns is self-balancing.

I claim as my invention—

1. In a fire-proof structure for buildings, the combination of columns provided with brackets, sagged tension bars supported on the brackets, and means for adjustably securing the bars to the columns to form a balanced construction; substantially as set forth.

2. In a fire-proof structure for buildings, the combination of columns provided with brackets, tension bars resting on the brackets, clamps secured to the bars, and tie rings surrounding the clamps of the different bars, whereby the bars are tied to the columns; substantially as and for the purpose set forth.
3. In a fire-proof structure for buildings, the combination of columns provided with brackets, bars resting upon the brackets, and having enlarged ends, clamps formed to fit the bars and being made in sections bolted together, and rings encircling the blocks adjacent to each column; substantially as and for the purpose set forth.

JACOB SEIPEL.

In presence of—
A. M. EBERSOLE,
C. G. EDWARDS.