

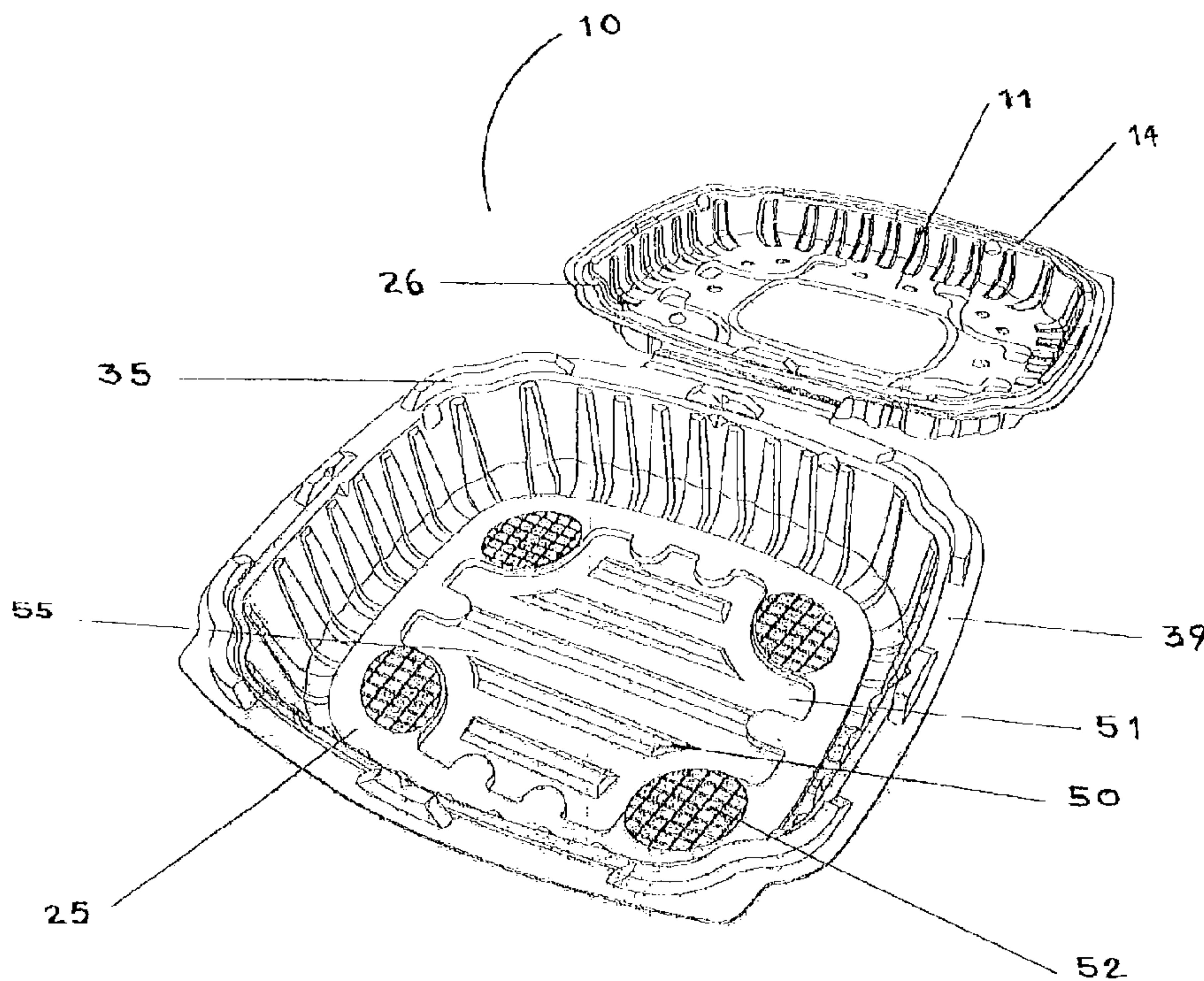

(86) Date de dépôt PCT/PCT Filing Date: 2010/06/18  
 (87) Date publication PCT/PCT Publication Date: 2010/12/23  
 (45) Date de délivrance/Issue Date: 2016/02/02  
 (85) Entrée phase nationale/National Entry: 2011/12/15  
 (86) N° demande PCT/PCT Application No.: US 2010/001761  
 (87) N° publication PCT/PCT Publication No.: 2010/147667  
 (30) Priorités/Priorities: 2009/06/19 (US61/218,770);  
 2010/03/05 (US12/718,635)

(51) Cl.Int./Int.Cl. *B65D 81/00* (2006.01),  
*B65D 21/032* (2006.01), *B65D 25/00* (2006.01),  
*B65D 25/02* (2006.01), *B65D 81/24* (2006.01)  
 (72) Inventeurs/Inventors:  
 POHLMAN, MICHAEL, US;  
 RIALES, BRENT, US;  
 CIMMERER, TIMOTHY LEE, US;  
 GARG, SATYA, US;  
 THALER, MICHAEL S., US  
 (73) Propriétaire/Owner:  
 ANCHOR PACKAGING, INC., US  
 (74) Agent: SMART & BIGGAR

(54) Titre : RECIPIENT POUR ALIMENTS AYANT UNE VENTILATION AMELIOREE  
 (54) Title: FOOD CONTAINER HAVING IMPROVED VENTILATION



(57) Abrégé/Abstract:

A plastic food container for crisp or crunchy foods includes a lid adapted for sealing arrangement with a base. Exhaust vents are selectively disposed on the top surface of the container, such that when the container is closed, rising vapors in the container easily flow out of the container. The convection movement of rising hot vapors causes the induction of ambient air into the container through a first air intake port and a counterpart air intake port disposed between the two engaged rims. The first intake port and its counterpart allow inducted air to enter directly and horizontally into the container. One or more channels are formed in the floor of the base and are aligned with a line defined by the first intake port and its counterpart to allow for the cross flow of drier inducted air underneath the container's food contents.

(12) INTERNATIONAL APPLICATION PUBLISHED UNDER THE PATENT COOPERATION TREATY (PCT)

(19) World Intellectual Property Organization  
International Bureau(43) International Publication Date  
23 December 2010 (23.12.2010)(10) International Publication Number  
**WO 2010/147667 A1**(51) International Patent Classification:  
*B65D 25/02* (2006.01)

(21) International Application Number:

PCT/US2010/001761

(22) International Filing Date:

18 June 2010 (18.06.2010)

(25) Filing Language:

English

(26) Publication Language:

English

(30) Priority Data:

61/218,770	19 June 2009 (19.06.2009)	US
12/718,635	5 March 2010 (05.03.2010)	US

(71) Applicant (for all designated States except US): **ANCHOR PACKAGING, INC.**; 13515 Barrett Parkway Drive, Suite 100, St. Louis, MO 63021 (US).

(72) Inventors; and

(75) Inventors/Applicants (for US only): **POHLMAN, Michael** [US/US]; 1035 Hidden Ridge Trail, Valley Park, MO 63088 (US). **RIALES, Brent** [US/US]; 2820 Brookside Drive, Paragould, AR 72450 (US). **CIMMERER, Timothy, Lee** [US/US]; 2211 N. 12th Avenue, Paragould, AR 72450 (US). **GARG, Satya** [IN/US]; 120 Royalgate Drive, St. Louis, MO 63141 (US). **THALER, Michael, S.** [US/US]; 140 Hamilton Way, Roswell, GA 30075 (US).(74) Agents: **SIMPSON, Daniel, T.** et al.; Gallop, Johnson & Neuman, L.C., 101 S. Hanley Road, Suite 1700, St. Louis, MO 63105 (US).

(81) Designated States (unless otherwise indicated, for every kind of national protection available): AE, AG, AL, AM, AO, AT, AU, AZ, BA, BB, BG, BH, BR, BW, BY, BZ, CA, CH, CL, CN, CO, CR, CU, CZ, DE, DK, DM, DO, DZ, EC, EE, EG, ES, FI, GB, GD, GE, GH, GM, GT, HN, HR, HU, ID, IL, IN, IS, JP, KE, KG, KM, KN, KP, KR, KZ, LA, LC, LK, LR, LS, LT, LU, LY, MA, MD, ME, MG, MK, MN, MW, MX, MY, MZ, NA, NG, NI, NO, NZ, OM, PE, PG, PH, PL, PT, RO, RS, RU, SC, SD, SE, SG, SK, SL, SM, ST, SV, SY, TH, TJ, TM, TN, TR, TT, TZ, UA, UG, US, UZ, VC, VN, ZA, ZM, ZW.

(84) Designated States (unless otherwise indicated, for every kind of regional protection available): ARIPO (BW, GH, GM, KE, LR, LS, MW, MZ, NA, SD, SL, SZ, TZ, UG, ZM, ZW), Eurasian (AM, AZ, BY, KG, KZ, MD, RU, TJ, TM), European (AL, AT, BE, BG, CH, CY, CZ, DE, DK, EE, ES, FI, FR, GB, GR, HR, HU, IE, IS, IT, LT, LU, LV, MC, MK, MT, NL, NO, PL, PT, RO, SE, SI, SK, SM, TR), OAPI (BF, BJ, CF, CG, CI, CM, GA, GN, GQ, GW, ML, MR, NE, SN, TD, TG).

Published:

— with international search report (Art. 21(3))

(54) Title: FOOD CONTAINER HAVING IMPROVED VENTILATION

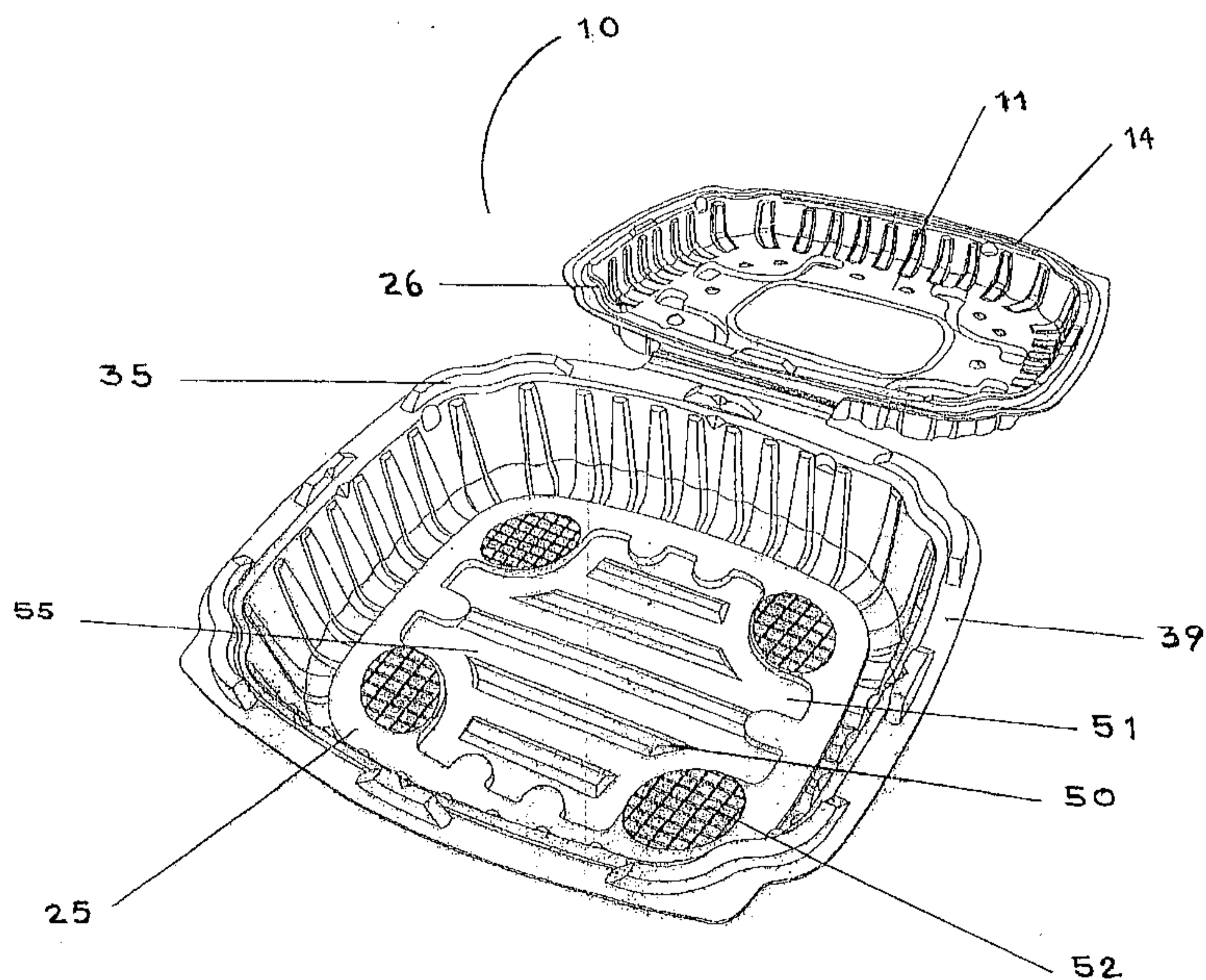

FIG 1

(57) Abstract: A plastic food container for crisp or crunchy foods includes a lid adapted for sealing arrangement with a base. Exhaust vents are selectively disposed on the top surface of the container, such that when the container is closed, rising vapors in the container easily flow out of the container. The convection movement of rising hot vapors causes the induction of ambient air into the container through a first air intake port and a counterpart air intake port disposed between the two engaged rims. The first intake port and its counterpart allow inducted air to enter directly and horizontally into the container. One or more channels are formed in the floor of the base and are aligned with a line defined by the first intake port and its counterpart to allow for the cross flow of drier inducted air underneath the container's food contents.

WO 2010/147667 A1

## FOOD CONTAINER HAVING IMPROVED VENTILATION

### FIELD OF INVENTION

**[0001]** This invention relates generally to ventilated plastic food containers. The invention is more specifically related to disposable plastic food containers designed to hold heated or freshly-cooked crisp, crunchy or texture-sensitive foods that require significant amounts of humidity removal.

### BACKGROUND OF THE INVENTION

**[0002]** It is known to use disposable plastic containers in the food preparation and restaurant industry to package prepared or take-out foods. The typical food container of the prior art consists of a clear or solid color base and a clear lid. The clear lid of the prior art plastic food container allows visible inspection of the container contents. The lid and base of the prior art plastic food container may be separate articles or may be hingedly attached to each other.

**[0003]** The lid and base of the prior art plastic container have complementary interlocking rim structures that seal the container. This interlocking rim arrangement is beneficial in preventing spillage of food contents from the container. In addition, this interlocking rim arrangement promotes heat build-up inside the container during microwaving and retains the temperature of hot foods placed in the container. When warm foods are placed in a closed container, steam and condensation can develop inside the container. This is particularly so when the container with warm food is placed into a storage area at room temperature or less. Steam and condensation may also form inside a

container holding food when the container is stored in an environment where external heat is applied to it (for example through microwaving, heat plates, heat lamps, warming tunnels, etc.). The build up of condensation and steam inside the container can result in the over-moistening of the contained food. This build up is particularly unwanted in the case of any food of sensitive texture, especially crisp or crunchy foods. In addition, undesirable food moistening is exacerbated when condensation drips down onto the food contents. In extreme cases, the condensate may pool at the bottom of the container leaving desirably crisp foods (e.g., vegetables) or crunchy foods (e.g., fried chicken or fried seafood) unpalatably soggy.

[0004] In the case of supermarket fried chicken (or seafood) for example, the supermarket prepares the fried chicken in its deli department, resulting in a cooked food product having a temperature of about 190 degrees Fahrenheit. After cooking, the hot fried chicken is placed into the container. The container may be sold immediately. If not, the container containing the fried chicken is typically placed in a heated display area and made available for sale as a “hot” food item for up to 4 hours. In the prior art container, the heat from the hot chicken builds up in the container and, in turn, causes moisture build-up in the container. As a consequence to this moisture build-up, the fried chicken’s crisp battered coating becomes soggy.

[0005] The solution to preventing over-moistening of cooked food, however, is not simply a case of providing unregulated venting. In the first respect, unregulated venting allows the food to dry out and over-harden. More importantly, in addition to palatability concerns, containers for cooked foods must address safety issues. If the container is

vented too much, the temperature of the fried chicken can drop below the minimum temperature required by health departments or good food serving practice. These same concerns hold true for other establishments like restaurants and with respect to other texture sensitive foods like unbreaded cooked crab that can degrade if heat and moisture are not properly removed from the container.

[0006] In order to maintain the crispness of food contents within a closed container, it is known to provide the prior art food container with exhaust ventilation means. In this regard, the lid of the prior art plastic food container typically contains one or two surface vents in the form of cruciate slits. The cruciate slits form near-circular tabs that can be deformed upward to permit egress of steam formed inside the container. The one or two slits are located on the surface of the container lid, not in relation to other venting structures of the container, but instead in a manner that detracts least from the aesthetic appeal of the container. Though these slits assist in the exhaust venting of steam gases from the container, moisture build-up inside the container still occurs.

[0007] In the case of microwavable storage containers (as opposed to deli case containers) manufacturers have chosen to deal with removal of moisture damaging steam by constructing container rims whereby the lid rim can assume two different positions on the base rim. One position keeps the container sealed. The other position allows exhaust venting. In the case of these latter containers, the sealed lid assumes a second fixed exhaust venting position on the base either through manual repositioning or by the lifting action of rising pressure inside the container. Once the lid is in the fixed exhaust venting position, steam can escape the container by flowing along and between the contour of the

rim structures and out through the container. The contour of these rim structures can require egressing steam to undergo flow restricting direction changes (including direction reversals). The drawback to these exhaust venting solutions is that they still result in the creation of interior vapors and condensation in the container, particularly in the case of the self-activating lid. Also, because air must flow around the contour of rims, these containers promote only the egress of air out of the container and do not allow drying air into the container.

**[0008]** U.S. Patent No. 6,257,401 discloses a thermoplastic container for food with a cover that is removably attached to the base to define a food storage chamber. A downwardly extending rib formed in the cover rim is intermittently provided with a plurality of notches that are aligned with respective notches formed in an upwardly extending elongated rib of the base. With the cover in place atop the base, the conjunction of the base notches and the cover notches define apertures. However, as is best shown in FIG. 11 of that patent, the notches of the lid rim and base rim are offset, such that air flow into the container is directed upward toward the upper apertures of the lid. Another set of apertures for additional ventilation are provided in the side walls of the cover.

**[0009]** Because of the venting drawbacks of the prior art container with respect to desirably crisp or crunchy foods, container manufacturers have designed containers having textured surface grids on the container floor that keep the food contents raised above pooled food juices or condensate. These grids can create pooling areas that collect the condensate and juices. The container of U.S. Patent No. 6,257,401 includes a plurality

54691-2

of small wells in the container bottom, the function of which is to purposefully retain food juices via capillary action or surface tension. These solutions, however, do not completely remedy the creation of food-damaging steam and fluids inside the container. In fact, they can make it worse. In particular, the condensate and juices may drip into and pool in the  
 5 wells of the container's floor grid and be retained. This pooled liquid absorbs heat and creates rising steam that infuses the lower portion of the container's food contents with texture damaging moisture.

**[0010]** There is thus a need in the art for a plastic food container that reduces steam creation and enhances container venting to prevent over-moistening of desirably crisp or  
 10 crunchy foods.

#### SUMMARY OF THE INVENTION

**[0011]** The present invention satisfies the need in the art and provides an aesthetically appealing food container that is easy to use, while providing for improved moisture removal. In this respect the present invention container achieves balanced vapor  
 15 removal by incorporating structures that enhance the exhaust venting of the container with structures that allow for efficient air intake. The container uses convection and guided flow of inducted air to prevent the over-moistening of food product.

**[0011a]** According to an aspect of the present invention, there is provided a plastic food container comprising: a lid and a base; the lid and base each having a peripheral rim;  
 20 the lid rim adapted for closing engagement with the base rim; when the lid rim and base rim are in closed engagement, the lid and base forming an interior of the container, a first intake port disposed between the two rims and a first counterpart intake port disposed between the two rims; the first intake port and the first counterpart intake port being further disposed between the two engaged rims such as to permit air to enter directly and generally  
 25 horizontally into the container; the first intake port and the first counterpart intake port defining a line in the interior of the container that extends from the first intake port to the first counterpart intake port; the base comprising a floor, the floor having a plurality of ribs projecting upwardly into the interior of the container; the plurality of upwardly projecting

54691-2

ribs forming at least one channel within the interior of the container and aligned with the line defined by the first intake port and the first counterpart intake port; the lid including a top surface and one or more outermost side surfaces, the one or more outermost side surfaces having no vents disposed on them; and the top surface of the lid having a plurality  
5 of exhaust vents disposed on it.

**[0012]** The present invention comprises a plastic food container including a lid and a base. The lid and base each have a peripheral rim. The lid rim is adapted for sealing engagement with the base rim. When the container is sealed with hot food contents, the heat load created by the food causes the moisture laden air to rise and exit through

selectively positioned and numbered exhaust vents in the top surface of the container lid. In this regard, the top surface exhaust vents are numbered and positioned in relation to the expected temperature and humidity of the container's contents. The convection movement of warm moist air upwardly in the container and through the top surface exhaust vents causes the induction of air through the intra-rim intake ports hereinafter described.

**[0013]** It is a further feature of the present invention container that the lid rim and base rim when in closed engagement form at least one first intake port disposed between the two rims. To achieve optimum balanced venting and eliminate humidity dead zones in the container, each first intake port has a counterpart intake port disposed between the two rims. Additionally, the first intake port and its counterpart intake port are oriented such as to permit air to enter, directly and generally horizontally, into the container through them and not encounter obstructing rim structures or have to change directions or angles while traveling through the rims.

**[0014]** The first intake port and its counterpart intake port define a line inside the container. The container's floor can have at least one channel formed in it, which is aligned with the line defined by the first intake port and a counterpart intake port. By aligning the floor channels with at least one intake port, a cross flow of inducted ambient air is allowed whereby the container promotes the flow of relatively drier air under the container's food contents. This flow of air not only helps evaporate collected condensate and food juices, it removes the vapor away from the underside of the food content,

preventing its damaging absorption. The container floor may comprise channels aligned with two or more sets of intake ports.

**[0015]** In more specific summary, the present invention plastic food container comprises a lid adapted for sealing arrangement with a base. The lid has a peripheral rim structure that complementarily engages the peripheral rim structure of the base. The base has a floor and a sidewall extending between the floor and the rim. In contrast to prior art containers utilizing through-the-rim exhaust or intake venting, it is a feature of the present invention that when the lid is fully closed to the base, the mating rim structures create at least two intake ports that allow generally horizontal and direct (unrestricted) flow of air into the container through the closed rims. Preferably, each intake port is located on the rim in opposing relationship to another intake port. Hence, each intake port is located such that it is across from another intake port on the other side of the container. The positioning of the intake ports allows for the cross-flow of air through the container.

**[0016]** In the preferred embodiment, the rim structure of the lid has a channel shaped to receive spaced apart projections on the base rim structure. When the lid is closed to the base, the channel of the lid rim structure receives the projections on the base rim structure. The height of the projections emanating from the base rim structure prevents the lid flange from sealing completely against the base flange. As a result, when the lid is fully engaged to the base, the spaces between the base rim projections create rim air intake ports.

**[0017]** The present invention container further comprises elevated (preferably embossed) projecting ribs from the base floor. These ribs create one or more channels on

the container floor that compared to the prior art are specifically aligned with a line defined by at least two intake ports located within the engaging container rims. These ribs and channels provide for several beneficial effects. First, as in the case with the grid or textured surface of the prior art container, the ribs keep the food contents elevated from the base floor and away from collecting liquids. However, in combination with the intake ports, the aligned channels act like baffles and allow for the free passage of gases and vapors underneath the food contents. Thus, should pooled liquids in the container start steaming, the channels of the present invention container allow for the evacuation of steam out through the top surface exhaust vents in the lid instead of into the food. In addition, by virtue of their alignment with the intake ports, the channels of the present invention container allow for the end-to-end cross flow of moisture-removing air underneath the container's food contents in the event a pressure differential exists between the ends of the channels. This arrangement not only enhances the removal of pooled moisture, but also aids in drying of the bottom of the food contents. Thus, the convective movement of warm air inside the container causes induction of air through the rim intake ports. That air, being relatively cooler than the existing vaporous air inside the container, drops to the floor of the container. This drop is effected, in part, by the generally horizontal (not upwardly angled) orientation of the rim intake ports. Once the cool, dry air reaches the container floor, it flows as guided by the channels. Thus, the intake ports along with the aligned, one or more channels allow the direct, unimpeded flow of relatively dry air to enter into the container from the intake ports and pass under the food contents. While passing under the food contents, heat is transferred from the

54691-2

food contents to the incoming air. That heated air rises, scavenging moisture from the existing air in the container as it rises.

[0018] To further enhance the convection flow in the container, the preferred embodiment container includes a plurality of exhaust vents disposed about the top surface of the container lid and not along any of the lid's outermost side surfaces. This arrangement of top-surface-only vents removes the dead-air effect caused by having apertures on the side of the lid in close proximity to the rim intake ports. By removing this dead-air effect, convection in the container is enhanced. In addition, by removing the vents from the extreme side of the lid by the intake ports, rising air in the container does not intercept the inducted air from the intake ports and push it out of the container.

[0019] While the invention is susceptible to various modifications and alternative forms, a specific embodiment thereof has been shown by way of example in the drawings and will herein be described in detail. It should be understood, however, that it is not intended to limit the invention to the particular forms disclosed. Quite to the contrary, the intention is to cover all modifications, equivalents, and alternatives falling within the scope of the invention as defined by the appended claims.

#### BRIEF DESCRIPTION OF THE DRAWINGS

[0020] FIG. 1 is a perspective view of a preferred embodiment of the present invention container in the open arrangement.

[0021] FIG. 2 is a perspective view of a preferred embodiment of the present invention container in the closed arrangement.

[0022] FIG. 3 is a plan view of the present invention container in the open arrangement.

[0023] FIG. 4 is a cross-section view taken along line A-A of FIG. 3.

[0024] FIG. 5 is a side elevation view of the preferred embodiment present invention container in the closed arrangement.

[0025] FIG. 6 is a perspective view of the inside of the base of the preferred embodiment present invention container.

[0026] FIG. 7 is a perspective view of the inside of the lid of the preferred embodiment present invention container.

[0027] FIG. 8 is a side elevation view of the lid of the preferred embodiment present invention container.

[0028] FIG. 9 is a side elevation view of the base of the preferred embodiment present invention container.

[0029] FIG. 10 is an enlarged view of detail area Z of FIG. 4.

[0030] FIG. 11 is an enlarged view of detail area Y of FIG. 4.

#### DETAILED DESCRIPTION

[0031] A preferred embodiment container 10 of the present invention in the open and closed arrangement is shown in FIGS. 1 and 2. In practical use, the outer surface of floor 31 of base 25 will normally rest upon a surface (such as a table top) considered horizontal in reference to the user. Thus, the directional terms "vertical" and "horizontal" and the like are used to describe the container 10 and its components with respect to the

orientation illustrated in **FIG. 2** and are employed merely for the purposes of clarity and illustration. For example, in the orientation shown in **FIG. 2**, lid **11** of closed container **10** is spaced "vertically" from the base **25**. The directional terms "inner," "outer," and the like are used herein with respect to the described container to refer to directions along the directional component toward and away from the geometric center of the container.

**[0032]** Container **10** is preferably thermoformed. As shown by the figures, container **10** is composed of lid **11** and base **25**. Lid **11** includes top surface **12**, descending surface (sidewall) **19** and multi-segment rim **14**. Lid **11** and base **25** are manufactured from a conventional plastic material. Lid **11** is preferably clear. Top surface **12** may include levels or features of varying height, but is preferably flat. It may also be contoured and have ribs **16** in accordance with the prior art to enhance such factors as container volume, strength, nesting of multiple lids, stackability of closed containers and see-through visibility. In the preferred embodiment, lid top surface **12** includes top plateau **15**. Sidewall **19** extends from top surface **12** to horizontal segment **17** and may include ribs **13** for strength. Horizontal segment **17** extends from sidewall **19** to vertical inner wall **18**. Sidewall **19** preferably includes ribs **7** for strength and, in the depicted preferred embodiment, represents an outermost side surface of the lid.

**[0033]** The structure of preferred embodiment lid rim **14** will now be discussed in further detail. As best shown in **FIG. 10**, lid rim **14** includes peripherally projecting segment **20**, which extends between inner wall **18** and outer wall **21**, creating channel **23**. The cross-section profile of segment **20** is generally horizontal. The profile, however, can be shaped to include structure such as ribbing, curves or bends to modulate rim rigidity or

flexibility so as to enhance the closing, sealing and opening functions of the rim as needed. The drawings depict a preferred embodiment cross-section profile of this peripherally projecting segment. As viewed in **FIG. 10** outer wall **21** extends downwardly between peripherally projecting segment **20** and peripheral flange **22**. Outer wall **21** is preferably angled to frictionally engage projection **35** further described below.

**[0034]** The structure of preferred embodiment rim structure **30** of base **25** is best shown in **FIG. 11**. Base **25** includes a bottom-most level or floor **31** adjoined to sidewall **32**. Sidewall **32** extends between base floor **31** and multi-segment rim **30**. Sidewall **32** preferably includes ribs **41** for strength. The structure of base rim **30** is adapted to complementarily engage the structure of lid rim **14** when lid **11** and base **25** are placed in sealing arrangement. In this respect, the lower portion of base rim **30** includes sidewall-to-rim transition segment **33**. Transition segment **33** flares outwardly from the top of sidewall **32** and curves upwardly into base shelf **34**. Base shelf **34** extends outwardly from base **25** and curves upwardly to form sealing projection **35**. Preferred embodiment container **10** has at least two sealing projections **35**. As viewed in **FIG. 11**, sealing projection **35** comprises outer vertical segment **36** and inner ascending segment **37**. Top sealing segment **38** spans between segments **36**, **37**. Peripheral flange **42** extends outwardly from segment **36**.

**[0035]** As shown in **FIG. 9**, projections **35** are located at spaced apart intervals on shelf **34** so as to create base rim gaps **39** between two adjacent projections. Each base rim gap **39** is preferably located so as to geometrically oppose a counterpart base rim gap **39** located on the container. For example, in the disclosed embodiment square container

depicted in **FIG. 1**, base rim gaps **39** are disposed in opposing relationship on each pair of parallel container sides. Lid rim structure **14** preferably contains similar projections **26** located on horizontal segment **17**. Projections **26** are complementarily located on rim structure **14** such that they align with and frictionally contact projections **35** when lid **11** is closed to base **25**. Projections **26** serve to buttress projections **35** and keep lid **11** from twisting about base **25**. Lid rim gaps **27** are disposed between projections **26** on lid rim **14**. In addition, by frictionally engaging projections **35**, projections **26** make the engagement between lid **11** and base **25** stronger. As shown in the drawings, the height of projections **35** emanating from the base rim structure prevents lid flange **22** from sealing completely against base flange **42**. As a result, when the lid is fully engaged to the base, projections **35** of base rim **30** are engaged by channel **23** and projections **26** of lid rim **14**. However, the height of engaged projections **35** is such that flange **22** and flange **42** do not meet when the lid is engaged by the base. In this regard, when the container is closed, one or more lid rim gaps **27** between projections **26** of the lid align both vertically and horizontally with a base rim gap **39** of the base rim. Hence, base rim gaps **39** between the base rim projections are now roofed by rim **14** and create at least two rim intake ports **40** that allow air to directly enter the container generally horizontally.

[0036] In carrying out the invention it is not important which rim, lid or base, is provided with the projections **35** or the engaging channel **23**. Accordingly, in another embodiment, base rim **30** could be provided with channel **23** and lid rim **14** could be provided with projections **35**. In fact, other rim engaging methods could be used as long

as the sealing rim structures of the lid and base create intake ports **40** when the rims are in sealing arrangement.

[0037] When the lid rim and base rim are in sealing arrangement, the container comprises at least one set of counterpart intake ports **40** (a first intake port and a first counterpart intake port). More specifically, in the present invention container, the lid rim and base rim when in closed engagement form at least one first intake port disposed between the two rims. In addition, it is a feature of the invention that each first intake port has at least one first counterpart intake port disposed between the two rims. In contrast to prior art containers, the intake ports of the present invention allow air to flow directly through the rims of the container and not travel a serpentine course through rim structure. In addition, in comparison to prior art containers, the intake ports of the present invention allow air to flow directly into the container in a generally horizontal manner without having to travel an angled path. Hence, in the present invention intake ports **40** are not angled toward the container top.

[0038] The at least one first intake port and its one or more first counterpart intake ports are disposed between the two rims such as to permit air to enter the container through an intake port, cross at least a portion of the interior of the container under the food contents and then, as it warms, rise and exit the container through the exhaust vents in the top surface of the lid. For balanced moisture removal, each first intake port **40** is located in the engaged rims **14, 30** and has at least one first counterpart intake port **40** similarly located in the engaged rims **14, 30**. In the shown preferred embodiment container, each first intake port **40** is located on the closed container such that it

geometrically opposes (is perpendicularly across from) one counterpart intake port **40** on the other side of the container. This arrangement enables the cross-flow of air underneath food contents throughout the entire container in the case of a pressure differential between the ends of the one or more channels. The invention thus allows drier air to flow into the container through an intake port **40**, under the container contents and out through the exhaust vents **28** in the top surface of the lid. Though the depicted embodiment container shows an intake port **40** to have only one counterpart intake port **40**, an intake port **40** may have more than one counterpart intake port **40**.

[0039] Floor **31** includes two or more ribs **50** and may have alternating levels or elevations for strength and fluid control. To further enhance food crispness, floor **31** of base **25** comprises ribs **50** in floor recess **51**. Floor recess **51** is a preferred embodiment feature. Ribs **50** project upward from floor recess **51**. Spaced apart elongated ribs **50** are aligned with the line defined by at least one set of counterpart intake ports **40** and form at least one channel **55**. The one or more channels **55** act as flow paths for the relatively drier air inducted into the container through intake ports **40**. In this regard, the formation of aligned channels **55** on floor **31** differs from the prior art container with floor bottoms provided with grids, wells or other structural features intended to capture and retain liquid. These structural floor elements, though useful in preventing sloshing of liquids or keeping food raised above pooled liquids serve as barriers to air flow underneath the container's food contents.

[0040] In the depicted preferred embodiment the one or more channels **55** are lengthwise centered along one dimension of the floor and extend substantially across the

length of the floor. Further, recess **51** is formed in floor **31** so as to guide incoming air to the channels and allow incoming air to fan (branch) out to the multiple of channels disposed in it. The at least one channel **55** is oriented such that it extends in the direction of one set of counterpart intake ports **40** and thus the sides of the channel act like interior baffles. In the disclosed embodiment, the container depicts six channels **55** aligned with intake ports **40** disposed on the ends of the container. By virtue of being oriented in this fashion, channel **55** allows steam gases that may form from pooled liquid to rise and be conveyed away from food contents by convection, thus reducing the over-moistening of the bottom of food. Additionally, by virtue of the intake ports **40**, drier air may flow into intake ports **40** and around and under the container contents. Specifically, by virtue of the baffle effect of channel **55**, drier air entering into the container through an intake port **40** may flow under food contents and exit out through top surface exhaust vents **28**. In an alternative embodiment, floor **31** could comprise a plurality of channels **55**, at least two of which are aligned in two different directions so as to provide channels that align with more than one set of counterpart intake ports **40**. Additionally, in the preferred embodiment, floor **31** includes textured surface platforms **52**. Platforms **52** are embossed (raised) above the interior surface of floor **31** (and thus substantially higher than the surface of recess **51**). By virtue of this arrangement, food contents are lifted off the surface of floor **31** and the drier air entering the container from the intake ports **40** can more easily flow under the food contents and into the one or more channels **55**.

[0041] The terms “opposing,” “opposed” or “opposite” as used herein to describe the location of the base rim gaps **39** or intake ports **40** means that the gaps or portals are

oriented to allow the flow of ventilation into the container through one port, through a certain length or width of the interior of the container and then toward at least one other intake port. Hence, in the depicted rectangular container embodiment, a first intake port 40 is situated on one side of the container and a counterpart intake port 40 is located across the container on the opposing parallel side of the container. In this case, the at least one other counterpart intake port 40 would be preferably, but not necessarily, located perpendicularly across from the first intake port 40. Similarly, with a round container, the set of counterpart intake ports 40 would be preferably, but not necessarily, diametrically across from each other. Variations in the locations of counterpart ports 40 (and gaps 39) and the alignment of the floor ribs 50 and channel 55 may be made such that air only flows through a portion of the container and not its entire width or length. For example, in a rectangular container the intake ports 40 could be located on adjacent sides of the container to promote the diagonal flow of cross ventilation. The cross flow of ventilation in such an embodiment would be enhanced by having one or more diagonally oriented floor channels 55 aligned with the intake ports. Additionally, each intake port 40 preferably has *at least* one counterpart intake port 40 to achieve cross flow ventilation. Thus, an intake port 40 could have more than one counterpart intake port 40.

[0042] As shown in FIG. 2 to further enhance the convection flow in the container, the lid of the preferred embodiment container includes a plurality of exhaust vents 28 disposed about the top surface 12 of the container lid. For optimum convection movement in the container, it is critical that exhaust vents 28 be disposed and arranged on the top surface 12 of the container and not on any of the outermost side surfaces of the

lid. Otherwise, the inductive action on intake ports **40** is lessened or the inducted air may not have an opportunity to drop to the container floor before being pushed out by convection forces. At the same time, to enhance convective movement inside the container it is preferable that the plurality of exhaust vents **28** on the top surface **12** of the lid be disposed away from the lid center so that they follow the contour (as viewed from overhead) of the lid shape. In the depicted embodiment shown in **FIG. 2**, an exemplary number and arrangement of surface exhaust vents is shown on an approximately 9" x 8" rectangular container. Tests on this exemplary embodiment show that the optimum convection movement in the container occurs with a plurality of 14 exhaust vents disposed in the shown pattern about the periphery of the top surface of the lid and located within the range of 1" to 1-1/4" (measured from the front edge of the vent) from the nearest outer edge of the top surface of the container. For most food service applications (side dish sized containers to entrée sized containers) a plurality of at least 8 top surface exhaust vents **28** works well, with the range of 8 to 14 vents (cruciate slit type) showing optimum results. As shown in **FIG. 2**, it is further preferable that exhaust vents **28** be disposed so that they direct rising gases and vapors outward in relation to the container's outermost exterior side surfaces. This arrangement of exhaust vents on the lid top surface and the absence of vents on the outermost side surfaces of the lid removes the dead-air effect caused by having apertures on the side of the lid in close proximity to (particularly above) the rim vents. By removing this dead-air effect, convection in the container is enhanced.

54691-2

[0043] A container constructed in accordance with the present invention can be manufactured in a variety of shapes and sizes, and is preferably formed of resins or plastic materials including, but not limited to, polyethylene, polypropylene, polyvinyl chloride or polyethylene terephthalate ("PET"). The container lid and base can be transparent or translucent, and may be colored in either instance. The size and number of intake and exhaust vents can be varied to accommodate the food heating environment or the requirements of the food placed in the container. The container can be made by a variety of processes including thermoforming, vacuum forming, blow molding, extrusion molding or injection molding. Further, the container can be of any shape, including round or polygonal. The lid and base of the container may be separate articles or may include the depicted hinge such that the lid and base are connected to each other in a clamshell configuration.

[0044] Having described the invention in detail, those skilled in the art will appreciate that modifications may be made of the invention without departing from its scope. Therefore, it is not intended that the scope of the invention be limited to the specific embodiment illustrated and described.

54691-2

CLAIMS:

1. A plastic food container comprising:

a lid and a base; the lid and base each having a peripheral rim;

the lid rim adapted for closing engagement with the base rim;

5 when the lid rim and base rim are in closed engagement, the lid and base forming an interior of the container, a first intake port disposed between the two rims and a first counterpart intake port disposed between the two rims;

10 the first intake port and the first counterpart intake port being further disposed between the two engaged rims such as to permit air to enter directly and generally horizontally into the container;

the first intake port and the first counterpart intake port defining a line in the interior of the container that extends from the first intake port to the first counterpart intake port;

15 the base comprising a floor, the floor having a plurality of ribs projecting upwardly into the interior of the container;

the plurality of upwardly projecting ribs forming at least one channel within the interior of the container and aligned with the line defined by the first intake port and the first counterpart intake port;

20 the lid including a top surface and one or more outermost side surfaces, the one or more outermost side surfaces having no vents disposed on them; and

the top surface of the lid having a plurality of exhaust vents disposed on it.

2. The container of claim 1 wherein the plurality of exhaust vents disposed on the top surface of the container lid numbers between eight and fourteen vents.

54691-2

3. The container of claim 1 wherein the lid includes a contour and the plurality of exhaust vents on the top surface of the lid are disposed on the lid top surface so that they follow the contour of the lid.

4. The container of claim 1 wherein the exhaust vents disposed on the top  
5 surface of the lid are formed so that they direct rising gases and vapors outward in relation to the outermost side surfaces of the lid.

5. The food container of claim 1 wherein when the lid rim and base rim are in closed engagement, the lid and base form a second intake port disposed between the two rims and a second counterpart intake port disposed between the two rims; and

10 the second intake port and the second counterpart intake port are disposed between the two engaged rims such as to permit air to enter directly and generally horizontally into the container.

6. The container of claim 5 wherein the second intake port and the second counterpart intake port define a second line in the interior of the container that extends  
15 from the second intake port to the second counterpart intake port and the plurality of upwardly projecting ribs form a second channel that is within the interior of the container and aligned with the second line.

7. The container of claim 1 wherein the peripheral rim of the lid comprises at least two sealing projections, the peripheral rim of the base has a channel and when the lid  
20 and base are in closed engagement the at least two sealing projections of the lid rim are engaged by the channel in the peripheral rim of the base.

8. The container of claim 1 wherein the lid is hinged to the base.

9. The container of claim 1 wherein the plurality of upwardly projecting ribs includes ribs of alternating levels.

25 10. The container of claim 1 wherein the floor includes a recess and the plurality of upwardly projecting ribs projects upwardly from the recess.

54691-2

11. The container of claim 1 wherein the floor includes textured surface platforms.
12. The container of claim 6 wherein the lid is hinged to the base.
13. The container of claim 6 wherein the plurality of upwardly projecting ribs  
5 includes ribs of alternating levels.
14. The container of claim 6 wherein the floor includes a recess and the plurality of upwardly projecting ribs projects upwardly from the recess.
15. The container of claim 6 wherein the floor includes textured surface platforms.

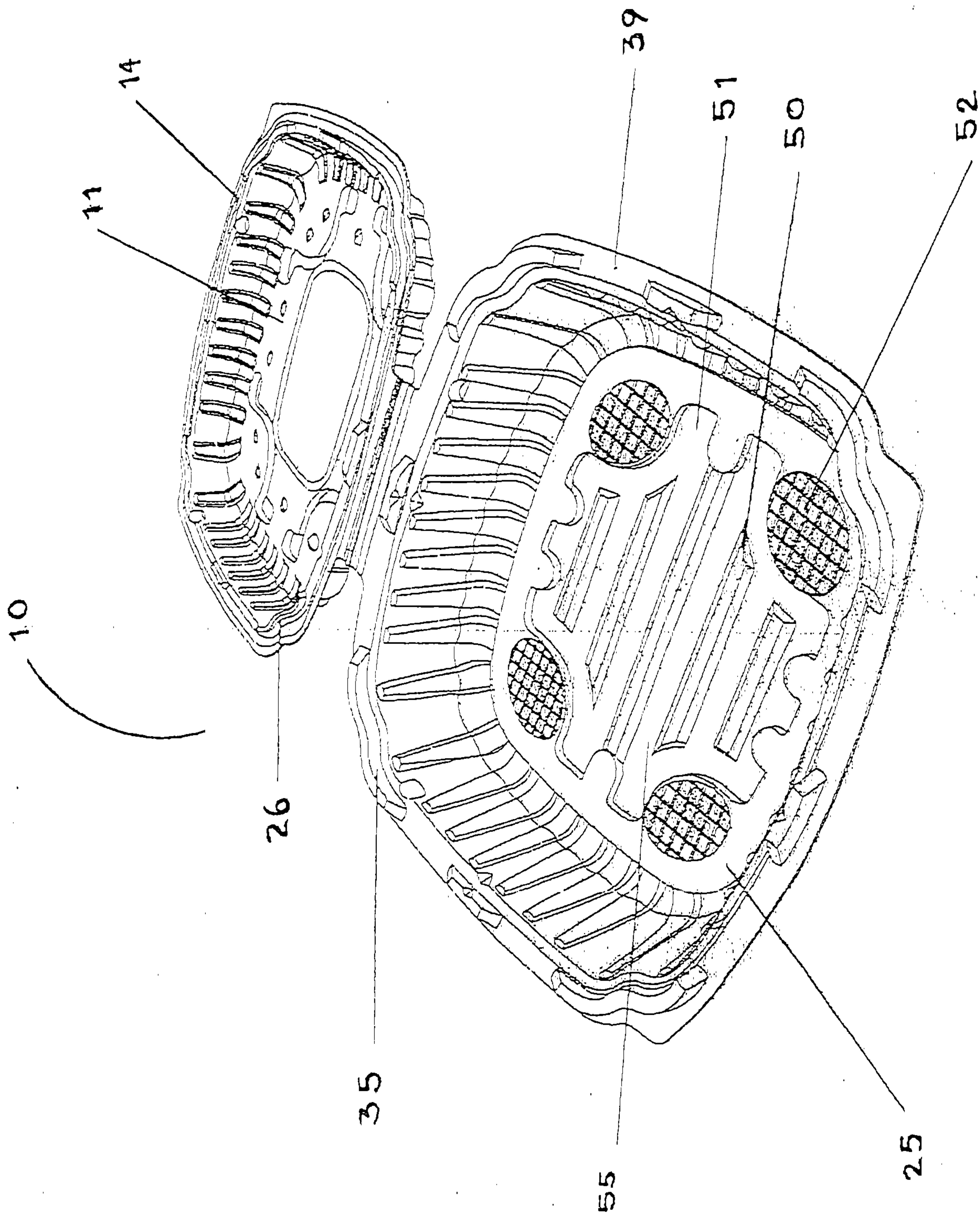

FIG 1

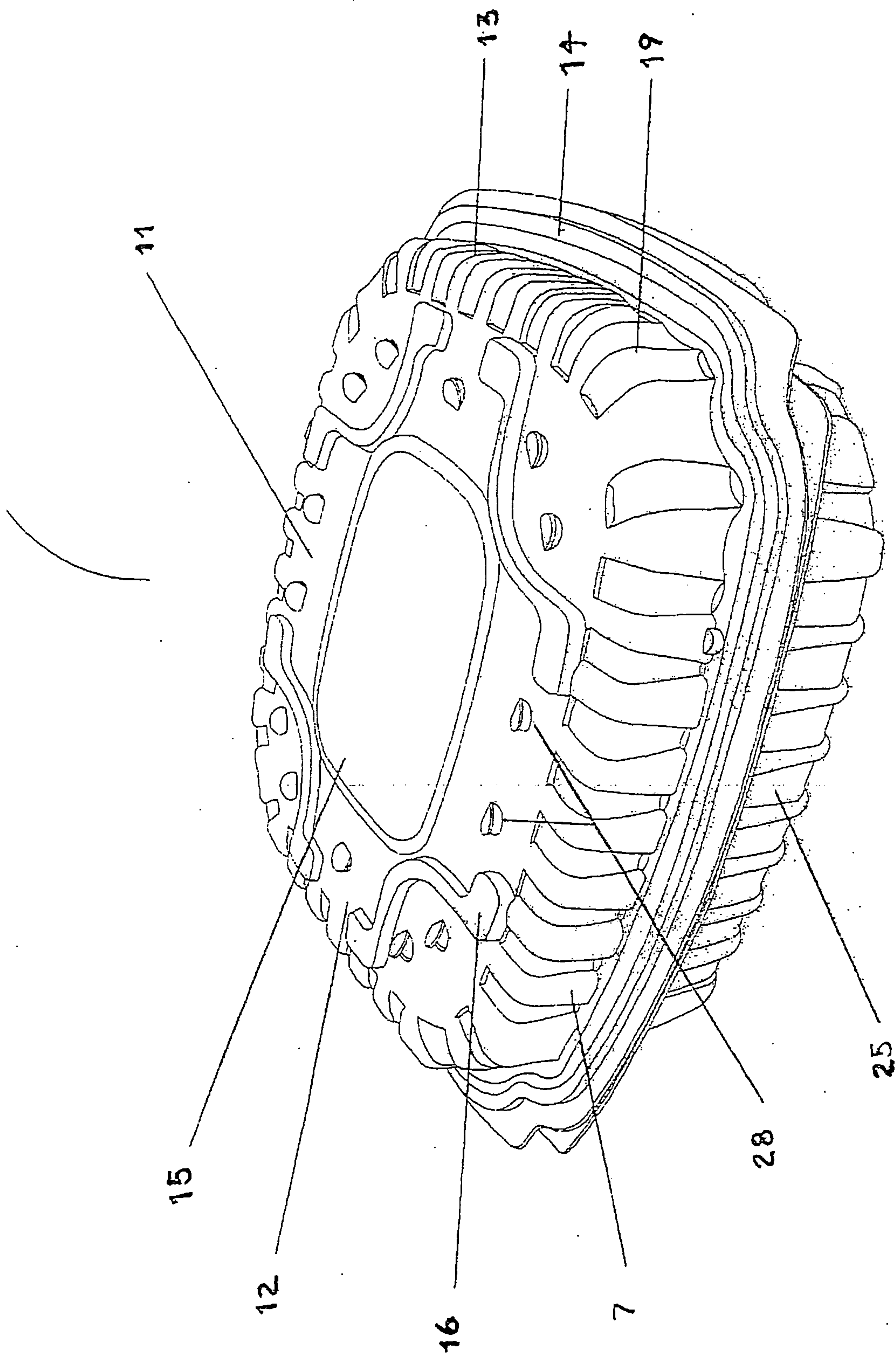

FIG 2

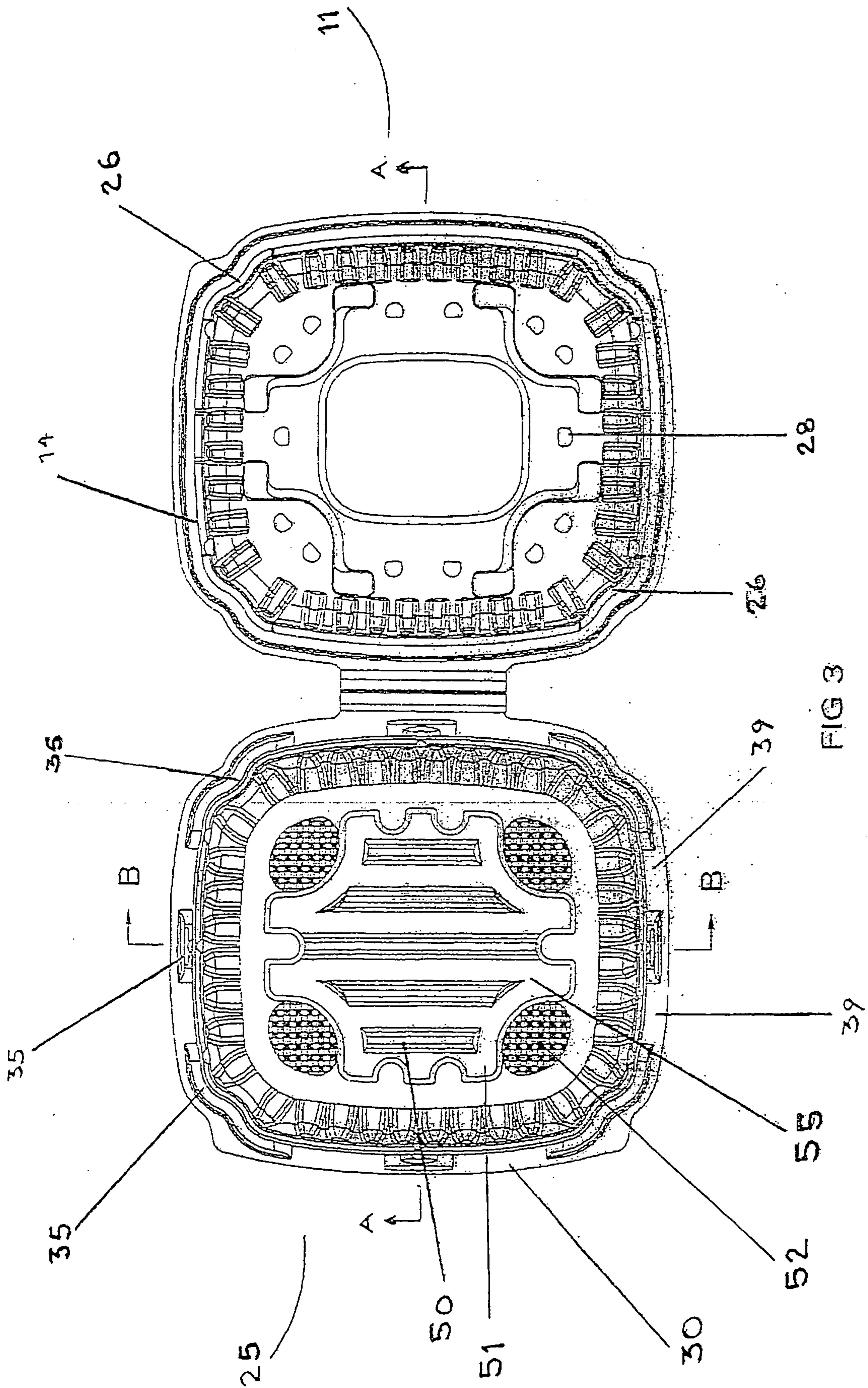

FIG 3

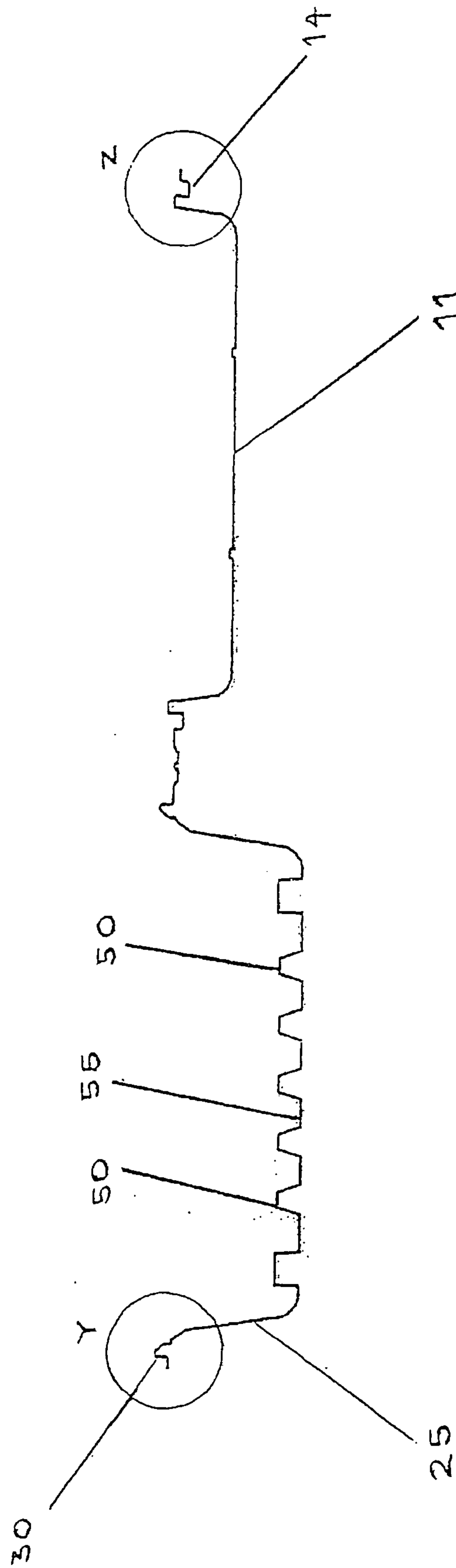

FIG 4

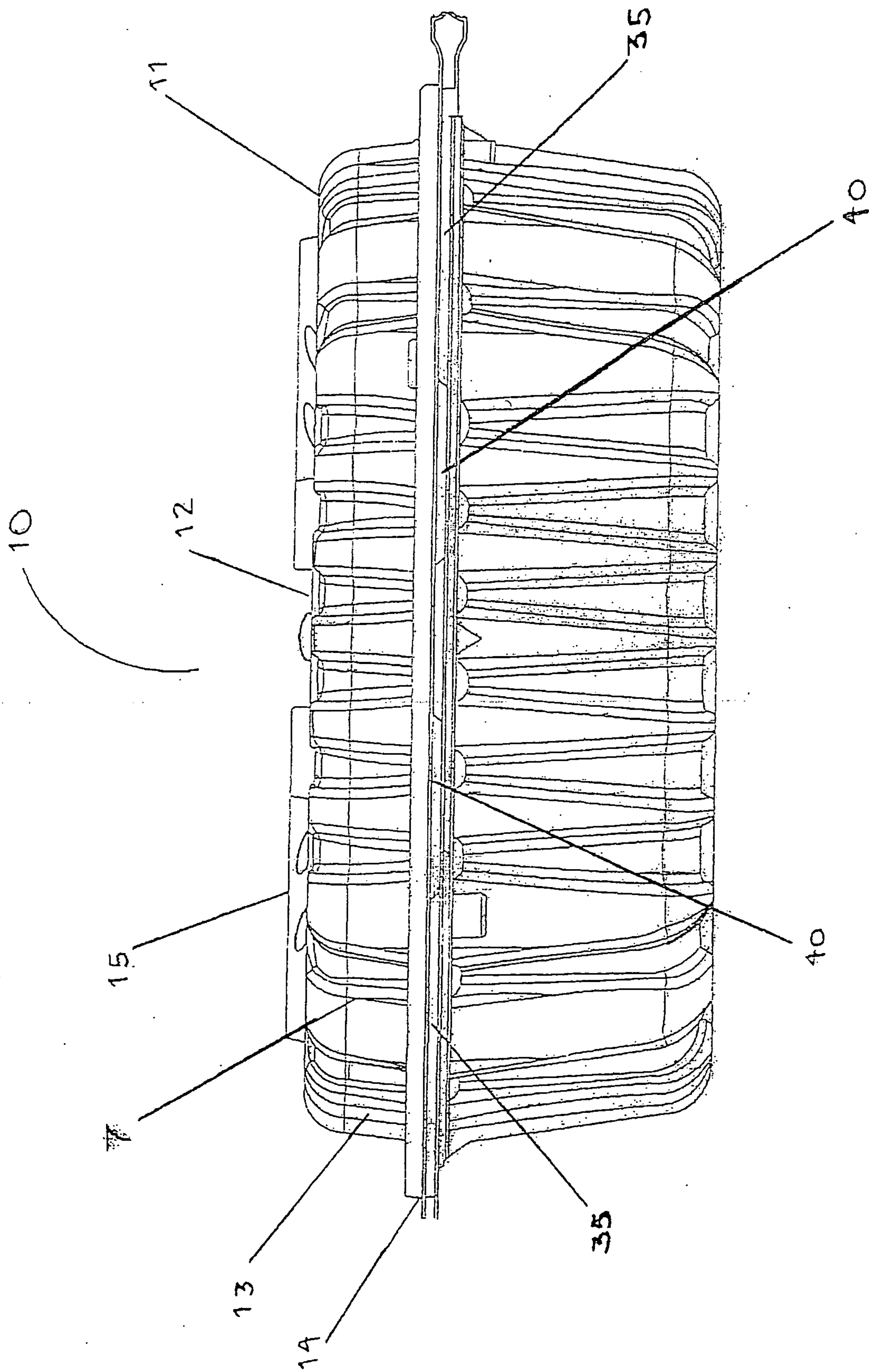

FIG 5

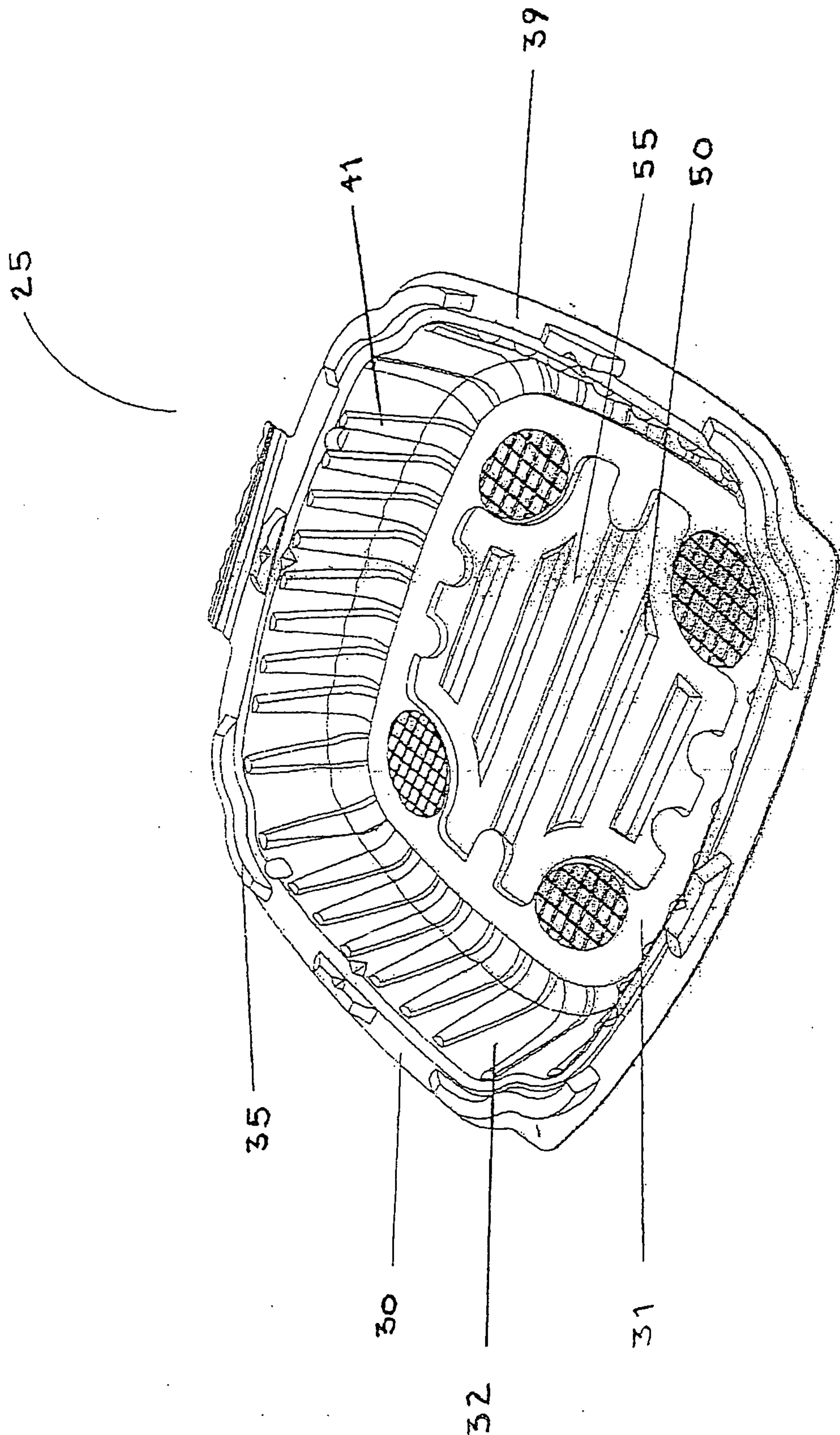

FIG 6

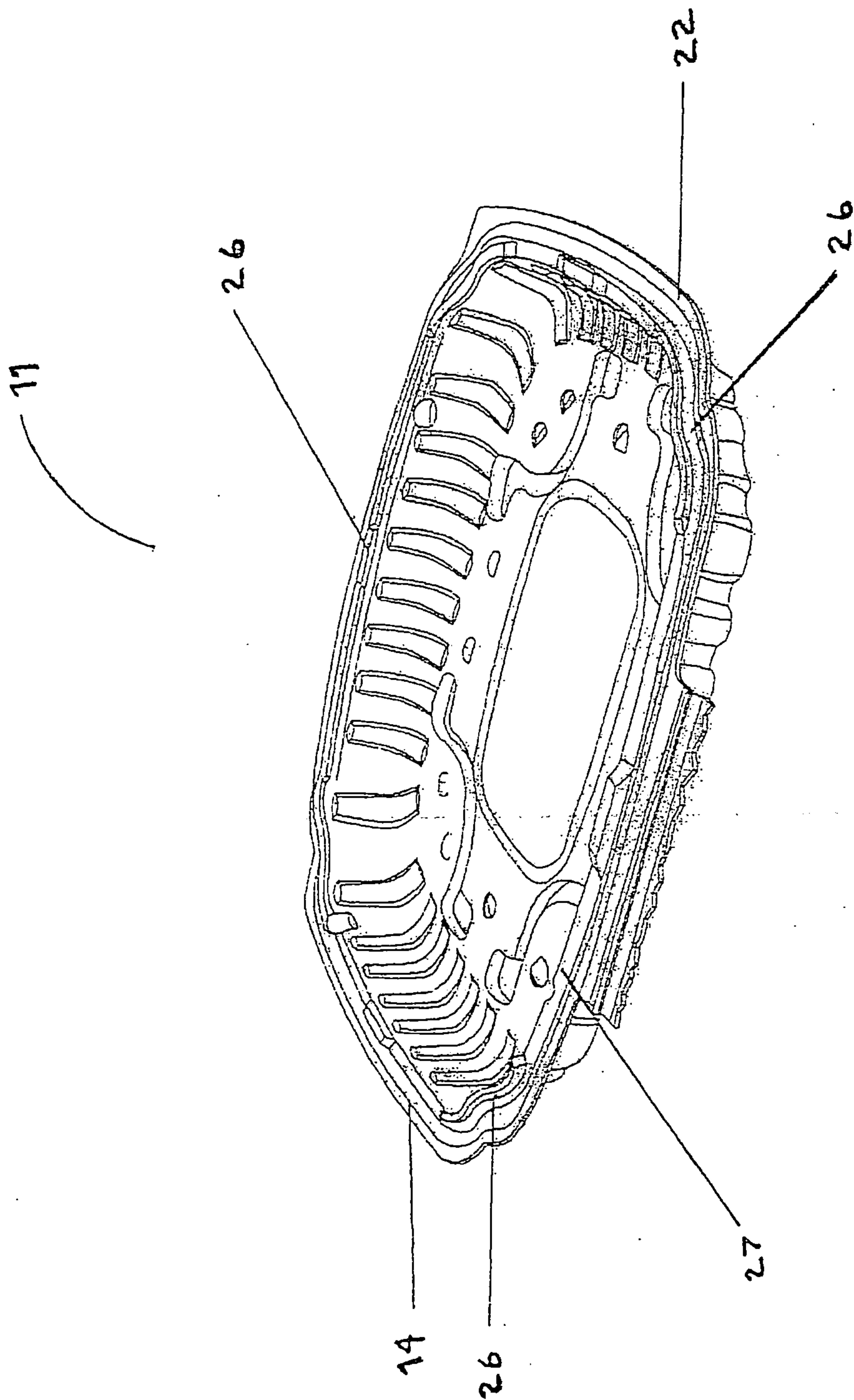

FIG 7

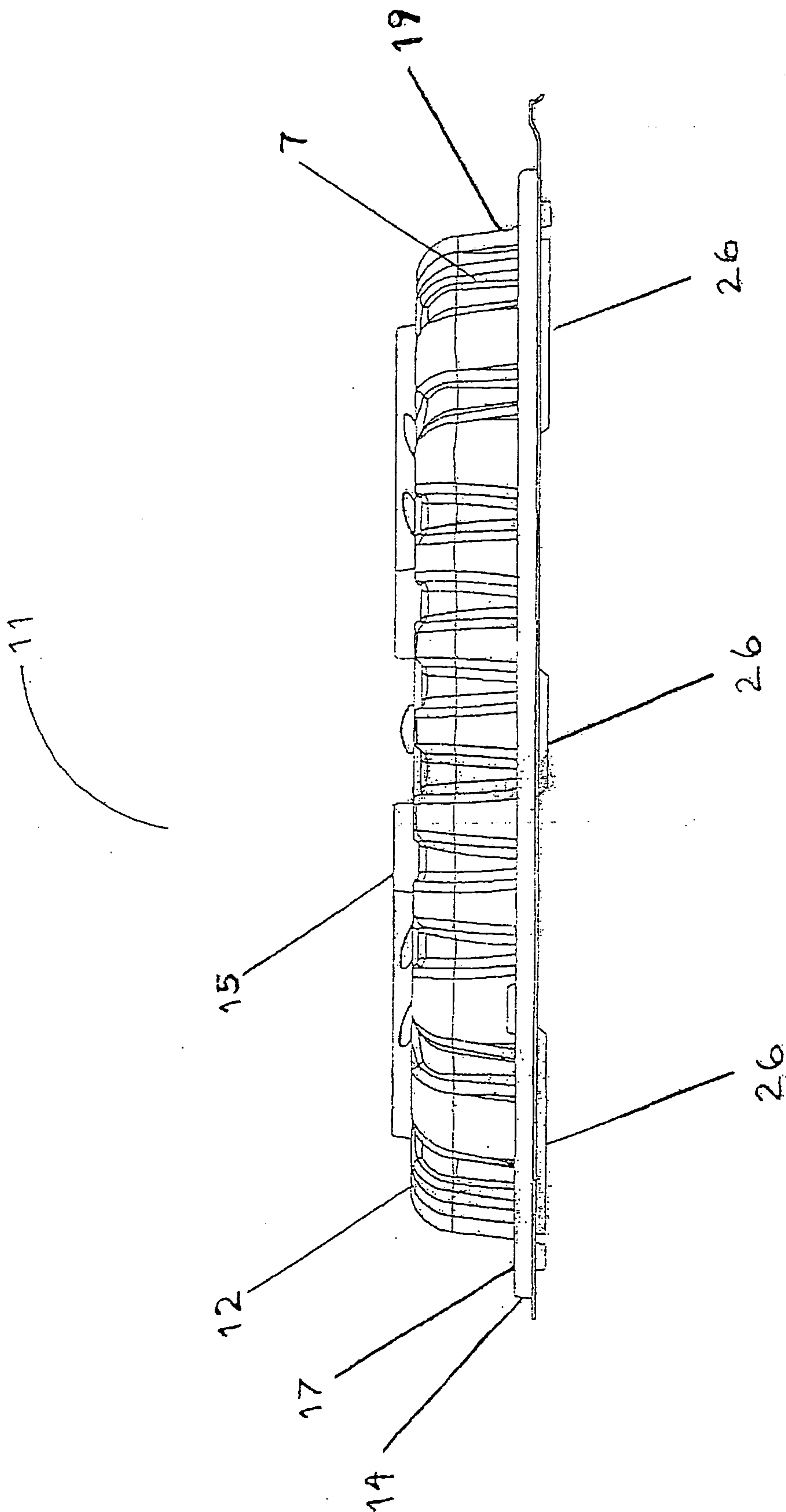

FIG 8

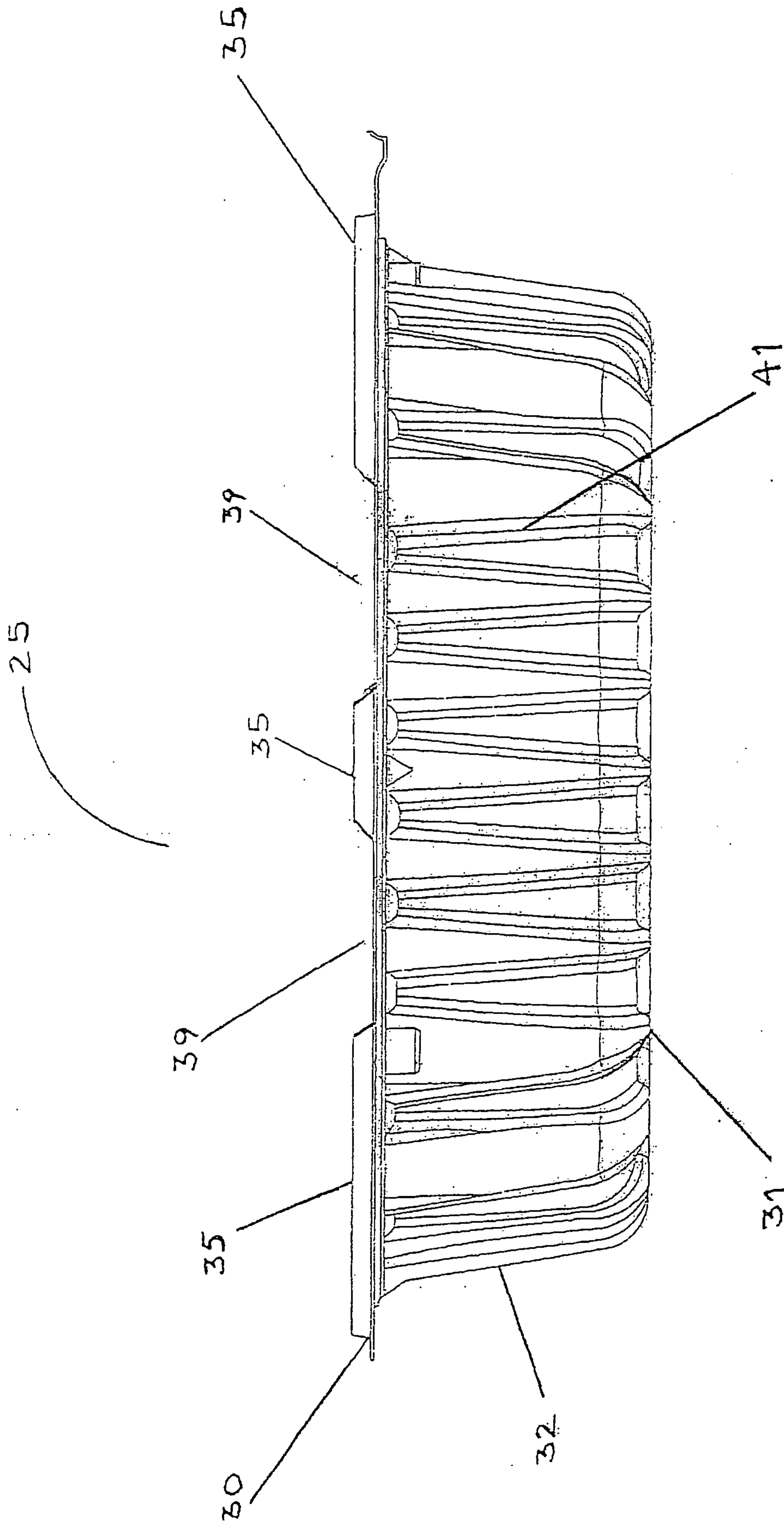

FIG 9

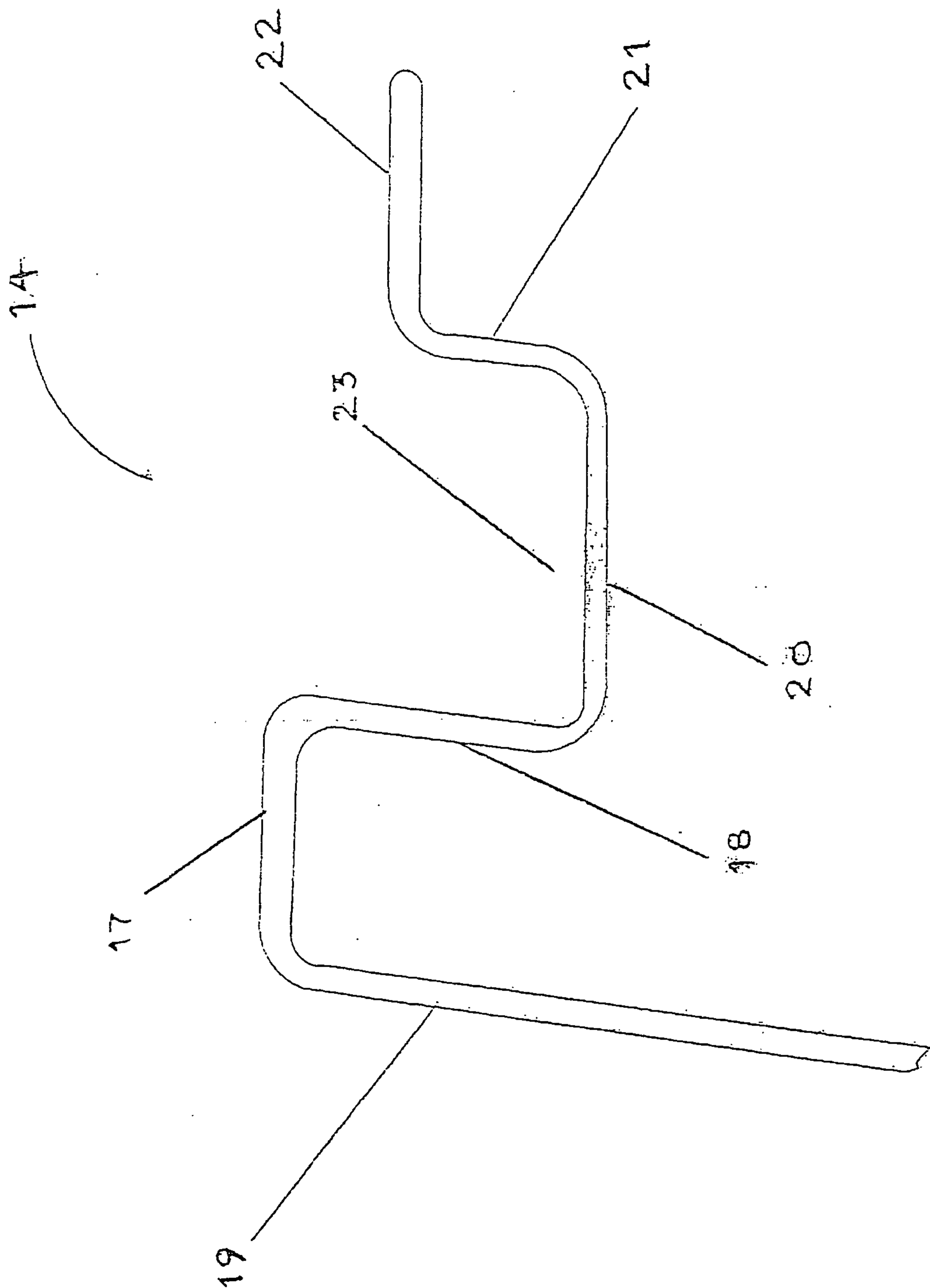

FIG 10

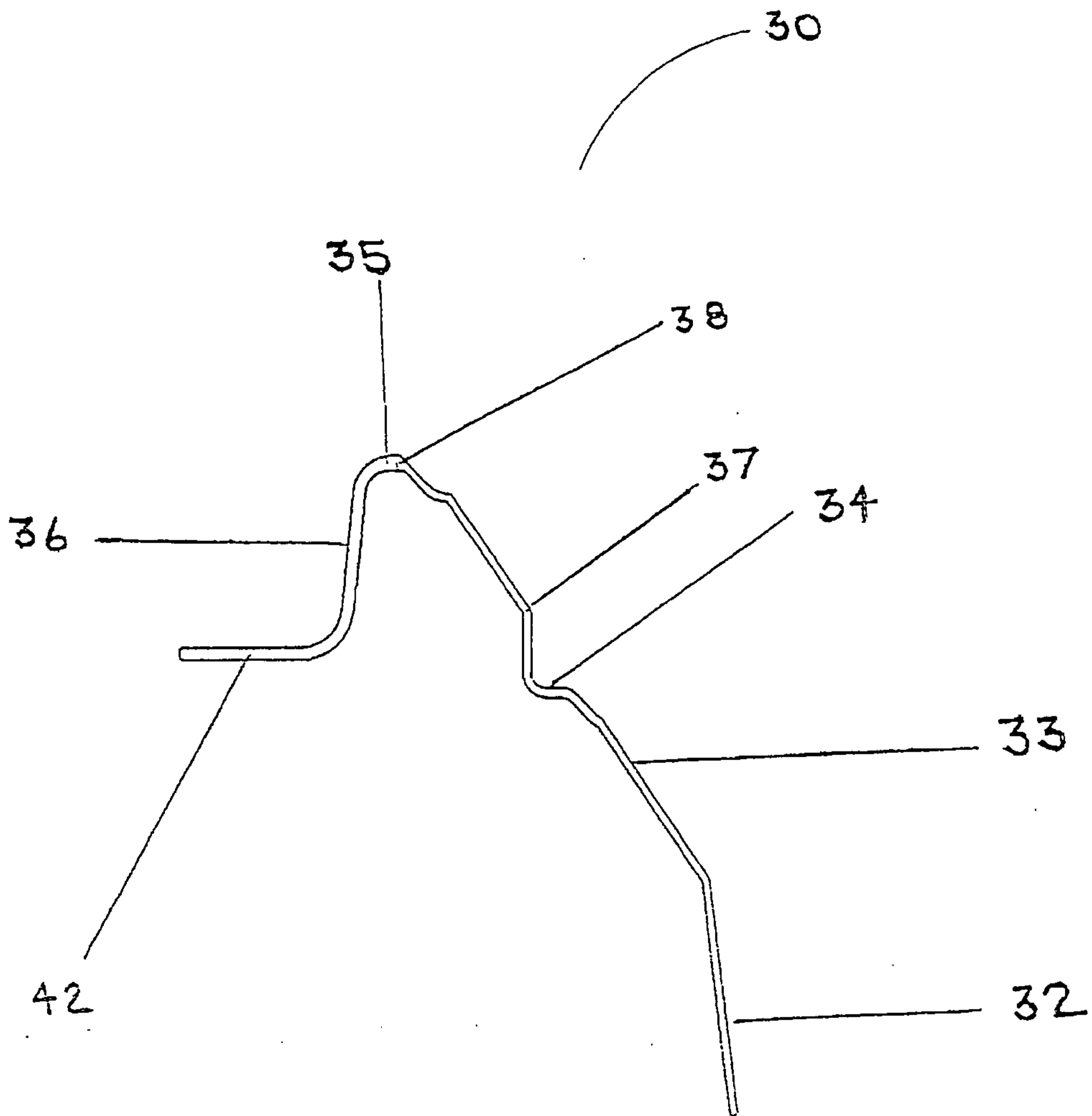

FIG 11

