

(19) World Intellectual Property Organization
International Bureau



(43) International Publication Date
17 March 2011 (17.03.2011)

(10) International Publication Number
WO 2011/031465 A1

(51) International Patent Classification:
A61B 17/04 (2006.01)

lege Ave., Tempe, AZ 85284 (US). HATCH, Laird [US/US]; 28403 N. 55th St., Cave Creek, AZ 85331 (US).

(21) International Application Number:
PCT/US2010/046579

(74) Agents: GRESHAM, Lowell, W. et al.; Meschkow & Gresham, P.L.C., 7250 North 16th Street, Suite 318, Phoenix, AZ 85020 (US).

(22) International Filing Date:
25 August 2010 (25.08.2010)

(81) Designated States (unless otherwise indicated, for every kind of national protection available): AE, AG, AL, AM, AO, AT, AU, AZ, BA, BB, BG, BH, BR, BW, BY, BZ, CA, CH, CL, CN, CO, CR, CU, CZ, DE, DK, DM, DO, DZ, EC, EE, EG, ES, FI, GB, GD, GE, GH, GM, GT, HN, HR, HU, ID, IL, IN, IS, JP, KE, KG, KM, KN, KP, KR, KZ, LA, LC, LK, LR, LS, LT, LU, LY, MA, MD, ME, MG, MK, MN, MW, MX, MY, MZ, NA, NG, NI, NO, NZ, OM, PE, PG, PH, PL, PT, RO, RS, RU, SC, SD, SE, SG, SK, SL, SM, ST, SV, SY, TH, TJ, TM, TN, TR, TT, TZ, UA, UG, US, UZ, VC, VN, ZA, ZM, ZW.

(25) Filing Language: English

(26) Publication Language: English

(30) Priority Data:
12/547,309 25 August 2009 (25.08.2009) US

(63) Related by continuation (CON) or continuation-in-part (CIP) to earlier application:
US 12/547,309 (CON)
Filed on 25 August 2009 (25.08.2009)

(71) Applicant (for all designated States except US): RED-LINE ORTHOPEDIC INNOVATIONS, INC. [US/US]; 5010 South Ash Ave, #103, Tempe, AZ 85282 (US).

(84) Designated States (unless otherwise indicated, for every kind of regional protection available): ARIPO (BW, GH, GM, KE, LR, LS, MW, MZ, NA, SD, SL, SZ, TZ, UG, ZM, ZW), Eurasian (AM, AZ, BY, KG, KZ, MD, RU, TJ, TM), European (AL, AT, BE, BG, CH, CY, CZ, DE, DK, EE, ES, FI, FR, GB, GR, HR, HU, IE, IS, IT, LT, LU, LV, MC, MK, MT, NL, NO, PL, PT, RO, SE, SI, SK, SM, TR), OAPI (BF, BJ, CF, CG, CI, CM, GA, GN, GQ, GW, ML, MR, NE, SN, TD, TG).

(72) Inventors; and

(75) Inventors/Applicants (for US only): LEDERMAN, Evan [US/US]; 5216 East Via Del Cielo, Paradise Valley, AZ 85253 (US). WINIKER, Dick [US/US]; 7901 S. Col-

[Continued on next page]

(54) Title: SUTURE ANCHOR AND METHOD OF USE

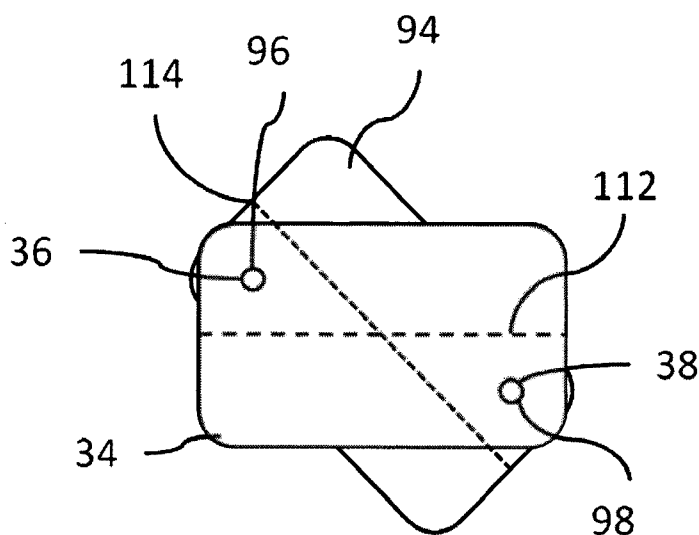

FIG. 8

(57) Abstract: A suture anchor (20) is inserted within the spongy bone (22'') such that only suture segments (40) and (42) extend into the cortical bone (22'). The suture anchor (20) is inserted with a suture inserting device (58) that holds the suture anchor (20) until suture inserting device (58) has entered spongy bone (22''). Deployment device (62) pushes the suture anchor (20) from suture inserting device (58) into spongy bone (22''). The suture anchor (20) is positioned such that the suture anchor (20) spans the hole (24) through which the suture inserting device (58) inserted the suture anchor (20).



WO 2011/031465 A1

Published:

— *with international search report (Art. 21(3))*

SUTURE ANCHOR AND METHOD OF USE

TECHNICAL FIELD

The present invention relates to the field of securing soft tissue within a patient. More
5 specifically, the present invention relates to securing a soft tissue to a bone.

BACKGROUND ART

The advantages of a minimally invasive procedure, such as arthroscopy, as opposed to an
open surgery, include less trauma to the patient, faster recovery time, shorter stays in
10 expensive medical facilities, to name but a few. As a result, the use of these types of
procedures has increased. Minimally invasive surgical procedures require the use of
instruments that can be positioned and placed within the body through a small incision,
requiring high precision while also being easy to maneuver and use. Among the many
procedures performed using such minimally invasive procedures include the treatment of
15 injuries such as torn cartilage or ligaments, requiring the fixation of soft tissue to bone for
proper healing.

Traditionally, in order to ensure that the sutures used will be able to secure the soft
tissue to the bone, surgeons have used suture anchors that affix to the bone, thus securing a
portion of the suture to the bone. This is done to increase the likelihood that the soft tissue
20 will reattach itself to the bone surface, rather than being pulled away. In order to use these
conventional devices, the surgeon will make a hole in the cortical bone, and insert the suture
anchor within the hole. The anchor is designed to secure itself within the cortical bone by
exerting some pressure on the cortical bone surface, digging into the bone itself, or any other
method that ensures that the anchor cannot be easily extracted from the bone. After the
25 anchor is secured, surgeons use the suture that is attached to the anchor to affix the soft tissue
to the bone.

Unfortunately, the level of growth of the soft tissue onto the bone may be limited
when using these devices. Some devices are designed so that a large portion of the anchor is
within the cortical bone; however a portion of the anchor, along with the suture, sits outside
30 the surface of the cortical bone. The protruding surface will often have contact with the soft
tissue that is being sutured to the cortical bone. The irritation caused by the anchor on the

soft tissue may prolong, if not hinder, full recovery from the surgical procedure.

Other conventional devices place the entire body of the suture anchor within the hole made in the cortical bone such that the no portion of the device extends beyond the outer surface of the cortical bone into the soft tissue, or beyond the inner surface of the cortical bone into the spongy bone. These suture anchors are placed under stress, as the sutures are pulled from the anchor to the outer surface of the bone. At times, this stress can cause the suture anchor to move, possibly resulting in a portion of the anchor ultimately protruding from the outside surface of the cortical bone, thus causing problems similar to those discussed earlier. Also, such movement of the anchor within the bone further increases the damage that is done to the cortical bone, and increases the likelihood that further treatment will be necessary to correct the injury.

The cortical bone is also capable of mending itself whenever it is damaged. However, similar to the soft tissue surrounding it, the cortical bone must be free from irritations or obstructions to heal quickly and properly. When conventional surgical anchors occupy an opening through the cortical bone, these devices can be causes for irritation, although the bone may grow around the anchor. This may result in increasing the time to full recovery, if not preventing full recovery all together.

Many times, individuals who undergo arthroscopies reinjure themselves in the same joints or other locations. As a result, oftentimes the same arthroscopic procedure must be done multiple times in the same area. Although the bone may heal itself, due to the method of installing these bone anchors, once one is in place, it cannot be removed without incurring further damage to the bone. As a result, if further injury is suffered at the same site, or in a close vicinity to the site where the suture anchor was installed, the previously installed suture anchor cannot be moved to make room for a new one. This reduces the options that are available to the patient for repairing the injuries they suffer.

There are some suture anchor devices that are not designed to occupy a hole through the cortical bone, but rather are designed to pass through the center of the bone, and come out to the other side. Because the anchor is not sitting within the bone itself, the need for small devices is not as much of a concern. By using the distal outer surface of the bone to support the sutures, the need to ensure that the suture anchor is well secured within the bone becomes unnecessary. However, in order to install these devices, it is necessary for the surgeon to

drill through both sides of a bone, and then pass this device through the bone to the other side. This maneuver is difficult, if not impossible, in minimally invasive surgeries, such as arthroscopies, as the device must be threaded through the bone and pulled out the other side.

Although this type of anchor does reduce if not nullify the irritation concerns that arise with other conventional suture anchors, the amount of trauma that the installation does to an individual's body is great. There is significant trauma to the bone, as it is necessary to drill through the cortical bone on the side where the device will enter the bone, through the spongy bone, and through the cortical bone on the opposite side where the device will exit the bone. This trauma is further increased by installing the device after the extensive hole-drilling operations are complete.

In order to install this anchor, the surgeon would have to pass one end of the anchor through the hole, grab the anchor on the other side of the bone, and properly position the device. This sort of device cannot be used in surgeries that are done in very small areas where the opposing side of the bone is not readily visible or accessible during a surgery. Also, in surgeries performed on bones that abut nerves, it would be virtually impossible for the surgeon to install this device without increasing the likelihood of serious injury to the patient. Furthermore, there is much more internal area of the bone that is exposed when this device is used. Unlike in the conventional suture anchors discussed above, this device will leave at least one hole in the bone that is not covered, and exposes the interior spongy bone to the outside. This provides more opportunity for complications from infection to arise.

BRIEF DESCRIPTION OF DRAWINGS

A more complete understanding of the present invention may be derived by referring to the detailed description and claims when considered in connection with the Figures, wherein like reference numbers refer to similar items throughout the Figures, and:

FIG. 1 shows a suture anchor as it is inserted into a bone in accordance with a preferred embodiment of the present invention;

FIG. 2 shows top-view of a suture anchor in accordance with a preferred embodiment of the present invention;

FIG. 3 shows a suture anchor inserting device in accordance with a preferred embodiment of the present invention;

-4-

FIG. 4 shows a profile view of a suture anchor holder in accordance with a preferred embodiment of the present invention;

FIG. 5 shows an exploded view of a suture anchor system in accordance with a preferred embodiment of the present invention;

5 FIG. 6 shows a top-view depicting a suture anchor prior to deployment in accordance with an alternative preferred embodiment of the present invention;

FIG. 7 shows a side-view depicting a suture anchor prior to deployment in accordance with an alternative preferred embodiment of the present invention; and

10 FIG. 8 shows a top-view depicting a suture anchor after deployment in accordance with an alternative preferred embodiment of the present invention.

BEST MODE FOR CARRYING OUT THE INVENTION

Fig. 1 shows a suture anchor 20 as it is inserted into a bone 22. Suture anchor 20 is designed to be inserted into bone 22 during minimally invasive surgical procedures. In those situations, the amount of space available for the devices to be positioned is minimal. Suture anchor 20 is inserted through a hole 24 in cortical bone 22'. In one embodiment, hole 24 is made prior to suture anchor 20 being inserted. In another embodiment, suture anchor 20 creates hole 24 as it is inserted through cortical bone 22'. In the embodiment that suture anchor 20 creates hole 24, suture anchor 20 will have an end that is tapered to a point (not shown), which is configured to aid in creating hole 24 for suture anchor 20. Suture anchor 20 includes a height 26, width 28, and length 30. Length 30 is greater than both height 26 and width 28.

Fig. 2 is a top-view of suture anchor 20. Suture anchor 20 is used to provide an anchor against which a suture 32 (Fig. 1) can be braced to while suturing soft tissue to a bone 22 (Fig. 1). In order to facilitate this, suture anchor 20 includes a sterile anchor segment 34 having a first hole 36 and a second hole 38. There is always a chance that a body may become exposed to a viral or bacterial infection. As an attempt to reduce this chance, operations are done in clean operation theaters, and individuals in the operating theaters go through extensive scrubbing procedures. Similarly, medical devices, such as anchor segment 34, that are used in surgical procedures are sterilized to ensure that the chances of infection when used in a patient's body are reduced. In one embodiment, sterile anchor segment 34

has rounded corners so as to reduce irritation inside bone 22 when suture anchor 20 is used. When suture anchor 20 is deployed, sterile anchor segment 34 rotates within bone 22 (discussed below). During this rotation, sharp corners on sterile anchor segment 34 may cause sterile anchor segment 34 to tear or otherwise damage the interior of bone 22. First hole 36 and second hole 38 extend through height of sterile anchor segment 34, and are configured to permit suture 32 to pass through from one side of suture anchor 20 to the other. A first suture segment 40 (Fig. 1) passes through first hole 36 and a second suture segment 42 (Fig. 1) passes through second hole 38. In one embodiment, suture anchor 20 is used as part of a knotless system, in which first suture segment 40 and second suture segment 42 are part of a single, integrated suture 32. In another embodiment, suture anchor 20 is used as part of a knotted system, where first suture segment 40 and second suture segment 42 are knotted together (not shown) on one side of suture anchor 20.

While providing an anchor for suture 32, a top surface 44 of suture anchor 20 is proximal to the inner surface 46 of a bone 22. In one embodiment top surface 44 has a contour that is similar to that of the inner surface 46 (Fig. 1) of cortical bone 22' (Fig. 1). To facilitate the flow of fluids from a spongy bone 22" (Fig. 1) to cortical bone 22' in the area occupied by suture anchor 20, at least a first groove 48 and a second groove 50 may be etched or otherwise formed into top surface 44. Permitting fluid flow in this way speeds the healing and regrowth process of cortical bone 22'.

Suture 32 is threaded through suture anchor 20 such that first suture segment 40 passes through first hole 36 and second suture segment 42 passes through second hole 38. First suture segment 40 and second suture segment 42 join at a back side 52 (Fig. 1) of suture anchor 20, and first and second suture segments 40 and 42 are available to place sutures proximal to an outer surface 54 of cortical bone 22'. When suture anchor 20 is inserted into bone 22, first hole 36 in anchor 20 will enter hole 24 in bone 22 before second hole 38 in anchor 20.

Returning to Fig. 1, after suture anchor 20 is fully inserted into bone 22, tension is applied to first suture segment 40, so that a side of suture anchor 20 proximal to first hole 36 is pulled towards inner surface 46 of cortical bone 22'. This will cause suture anchor 20 to rotate from an axis 56 aligned with the direction of movement through the hole 24, span hole 24, and thus provide an anchor for any sutures that may be placed in the soft tissue. After

suture anchor 20 is inserted, it cannot be extracted from hole 24 without properly aligning suture anchor 20 which cannot be done without additional maneuvering of suture anchor 20. In one embodiment, rounded corners for sterile anchor segment 34 may also help the rotation that is needed to properly position suture anchor 20 by making it less likely that suture anchor
5 20 will bind up during deployment but will rotate in two dimensions to span hole 24 even when the corners of suture anchor 20 contact structures in bone 22.

When minimally invasive surgical procedures are used in concert with suture anchor 20, it may be difficult to insert and position suture anchor 20, as such procedures are conducted through small incisions in the patient. To aid in the insertion, deployment and
10 positioning of suture anchor 20, a suture anchor inserting device may be used.

Fig. 3 shows a suture anchor inserting device 58. Suture anchor inserting device 58 has a positioning unit 60 and a deployment device 62. Although Fig. 3 depicts deployment device 62 removed from positioning unit 60, during use deployment device 62 may be inserted into positioning unit 60 and move laterally within positioning unit 60 under the
15 control of a human or mechanical operator. Positioning unit 60 is configured to hold suture anchor 20 during insertion of suture anchor 20 into bone 22, and to position suture anchor 20 within bone 22 prior to deployment. Once suture anchor 20 is deployed, positioning unit 60 also may be used to position suture anchor 20 such that suture anchor 20 spans hole 24. Deployment device 62 is configured to deploy suture anchor 20. Deployment device 62 does
20 this by pushing suture anchor 20 from positioning unit 60 once positioning unit 60 has been inserted into bone 22.

Positioning unit 60 includes a positioning handle 64, a positioning shaft 66 and a suture anchor holder 68. Suture anchor holder 68 is configured to hold suture anchor 20 prior to deployment in bone 22. Suture anchor holder 68 is affixed to positioning shaft 66.
25 Positioning shaft 66 has a length 70 such that when positioning unit 60 is used, positioning shaft 66 will extend from the interior of bone 22 to outside a patient's body. Positioning handle 64 is affixed to positioning shaft 66 at an end distal from suture anchor holder 68. Positioning handle 64 is configured to permit a user of suture inserting device 58 to position suture anchor holder 68 within bone 22 from outside a patient's body.

Deployment device 62 includes a deployment handle 72, a deployment shaft 74 and a deployment end 76. Deployment end 76 is configured to push suture anchor 20 from suture
30

anchor holder 68. When deployment end 76 pushes suture anchor 20, it encourages a rotation of suture anchor 20 from axis 56 (Fig. 1) aligned with the direction of movement through hole 24. (discussed below). Deployment shaft 74 has a length which is at least equal to the length of positioning shaft 66 such that deployment end 76 will be able to touch and push
5 suture anchor 20 out of suture anchor holder 68. Affixed to deployment shaft 74, distal from deployment end 76, deployment handle 72 is configured to permit a user of suture inserting device 58 to apply pressure and push suture anchor 20 (Fig. 2) from suture anchor holder 68.

Positioning handle 64 and positioning shaft 66 have a hole 78 configured to accept deployment device 62. To deploy suture anchor 20 from suture anchor holder 68,
10 deployment end 76 is placed in hole 78 at positioning handle 64, and deployment device 62 is pushed into positioning unit 60 such that deployment end 76 travels the length of positioning shaft 66 and reaches suture anchor holder 68 (discussed below).

Fig. 4 is a profile view of suture anchor holder 68. Suture anchor holder 68 holds suture anchor 20 (Fig. 2) such that it cannot become dislodged until it is pushed out by
15 deployment device 62 (Fig. 3). In one embodiment, suture anchor holder 68 uses frictional forces to hold suture anchor 20. In another embodiment, a flap (not shown), closed by deployment end 76 (Fig. 3) approaching suture anchor holder 68, prevents suture anchor 20 from being released from positioning unit 60.

Suture anchor holder 68 is configured to permit suture anchor 20 to rotate from axis
20 56 (Fig. 1) as suture anchor 20 is released from suture anchor holder 68. To facilitate this, in one embodiment, suture anchor holder 68 has an open side 80 and a closed side 82. When examining the cross-sectional view of suture anchor holder 68, open side 80 is not covered, resulting in suture anchor holder 68 having a substantially "U" shaped cross-section.

In one embodiment, when suture anchor 20 is held in suture anchor holder 68,
25 grooves 48 and 50 (Fig. 2) are able to accept first suture segment 40 and second suture segment 42, so that first suture segment 40 and second suture segment 42 do not intertwine or otherwise become damaged or tangled during insertion and deployment.

Fig. 5 shows suture anchor system 84 as it deploys suture anchor 20 within bone 22. Suture anchor system 84 includes suture anchor inserting device 58 (Fig. 3) and suture
30 anchor 20 held within suture anchor holder 68. Suture anchor 20 is placed within suture anchor inserting device 58 prior to inserting suture anchor inserting device 58 within bone

22. To insert suture anchor 20 into bone 22, hole 24 is formed through cortical bone 22' from outside bone 22 to spongy bone 22". It is not necessary to form hole 24 through both sides of bone 22, as this is unnecessary trauma that is placed on bone 22. Hole 24 has a width greater than width 28 (Fig. 2) of suture anchor 20 and a height less than height 26 (Fig. 2) of suture anchor 20 so that suture anchor 20 may enter hole 24.

Fig. 5 shows suture anchor holder 68 of suture anchor system 84 holding suture anchor 20, and deployment device 62 deploying suture anchor 20. Prior to deployment suture anchor system 84 is inserted into bone 22 such that suture anchor holder 68 is within spongy bone 22". When suture anchor holder 68 is within spongy bone 22", suture anchor 20 is also within spongy bone 22". Thus, when deployed, suture anchor 20 will not be caught within cortical bone 22', but rather will sit within spongy bone 22". When suture anchor holder 68 has been positioned, deployment device 62 is inserted within positioning unit 60, if it has not already been positioned there. Deployment end 76 comes in contact with suture anchor 20 at a point 86 and pushes suture anchor 20 from suture anchor holder 68. Suture anchor 20 then rotates from axis 56 aligned with the direction of motion of positioning unit 60 through hole 24. To encourage this rotation, in one embodiment, point 86 is off-center from suture anchor 20. By positioning point 86 proximal to closed side 82, suture anchor 20 can be encouraged to rotate at open side 80, such that a leading edge 88 rotates out of suture anchor holder 68.

In one embodiment, positioning unit 60 may also be used to align suture anchor 20 such that suture anchor 20 spans hole 24 prior to removing positioning unit 60. In this embodiment, after suture anchor 20 is deployed using deployment device 62, first suture segment 40 is pulled so that a side of suture anchor 20 proximal to first hole 36 is pulled towards positioning handle 64. This will cause suture anchor 20 to further rotate from axis 56. Second suture segment 42 is also pulled, so that top surface 44 (Fig. 2) of suture anchor 20 touches an edge 90 of suture anchor holder 68. In one embodiment, when top surface 44 of suture anchor 20 touches edge 90, suture anchor 20 axis 92 is perpendicular to axis 56.

After suture anchor 20 is thus aligned, suture anchor inserting device 58 is extracted from hole 24 and suture anchor 20 spans hole 24. First suture segment 40 and second suture segment 42 extend from outside hole 24 to inside spongy bone 22" through hole 24.

Figs. 6-7 show a top and side view of an alternate embodiment of suture anchor 20 prior to deployment. In this embodiment, suture anchor 20 has two sterile anchor segments 34 and 94. First sterile anchor segment 34 has a first hole 36 and a second hole 38. Second sterile anchor segment 94 has a third hole 96 and a fourth hole 98. First hole 36, and second hole 38 extend through first sterile anchor segment 34, and third hole 96 and fourth hole 98 extend through second sterile anchor segment 94. First 36, second 38, third 96 and fourth 98 holes are configured to permit suture 32 to pass through from one side of suture anchor 20 to the other. A distance 100 between first hole 36 and second hole 38 and a distance 102 between third hole 96 and fourth hole 98 are substantially equal. First suture segment 40 passes through first hole 36 and third hole 96 and second suture segment 42 passes through second hole 38 and fourth hole 98. Because distance 100 and distance 102 are substantially equal, when suture anchor 20 is deployed (discussed below), first hole 36 and third hole 96 become aligned and second hole 38 and fourth hole 98 become aligned.

In one embodiment, when first sterile anchor segment 34 and second sterile anchor segment 94 are positioned for insertion into bone 22 (Fig. 7), top surface 104 of first sterile anchor segment 34 and a bottom surface 106 of second sterile anchor segment 94 are substantially parallel. A bottom surface 108 of first sterile anchor segment 34 and a top surface 110 of second sterile anchor segment 94 may also be tapered. Tapering bottom surface 108 of first sterile anchor segment 34 and top surface 110 of second sterile anchor segment 94 encourages a rotation of second sterile anchor segment 94 upon deployment (discussed below).

Fig. 8 is a top-view of the alternate embodiment of suture anchor 20 shown in Fig. 6 after deployment. Once suture anchor 20 has been deployed within bone 22, and first suture segment 40 and second suture segment 42 have been pulled so that suture anchor 20 is adjacent to cortical bone 22' within spongy bone 22", first hole 36 and third hole 96 are aligned, and second hole 38 and fourth hole 98 are aligned. Thus, first suture segment 40 passes through first hole 36 and third hole 96 without any substantial folds or bends. Similarly, second suture segment 42 passes through second hole 38 and fourth hole 98 without any substantial folds or bends.

First sterile anchor segment 34 is centered around an axis 112. Second sterile anchor segment 94 is centered around an axis 114. Prior to deployment, axis 112 and axis 114 are

aligned, as may be imagined by viewing Fig. 6. This alignment of axis 112 and axis 114 reduces the exposed surface area of suture anchor 20, and aids in reducing the size of hole 24 used to insert suture anchor 20. When deployed, pulling first suture segment 40 causes first hole 36 and third hole 96 to align. Pulling second suture segment 42 causes second hole 38 and fourth hole 98 to align. The alignment of holes 36, 38, 96, and 98 causes axis 114 of second sterile anchor segment 94 to rotate from axis 112 of first sterile anchor segment 34, as shown in Fig. 8. This rotation of axes increases the surface area of suture anchor 20, and provides a greater area inside spongy bone 22" upon which forces placed on suture anchor 20 can be distributed. One skilled in the art will recognize that although Figs. 6-8 and the related descriptions discuss the use of two sterile suture segments, any number of sterile suture segments may be used to effect the distribution of force.

In summary, the present invention teaches a suture anchor 20 that is inserted within the spongy bone 22" and does not extend into cortical bone 22'. First suture segment 40 and second suture segment 42 extend from the suture anchor 20 and through cortical bone 22' through hole 24 drilled by a surgeon as part of the surgical procedure. Because suture segments 40 and 42 are the only aspect of suture anchor 20 that impede the healing of bone 22, the healing will be faster, and the healed bone 22 will be stronger.

Suture anchor 20 requires only one hole 24 in order to be installed. Suture anchor inserting device 58 passes through hole 24, and inserts suture anchor 20 into spongy bone 22". Thus, no additional incisions are necessary to access and position suture anchor 20.

As suture anchor 20 is not secured within bone 22, if additional surgeries to the same or proximal areas are necessary, suture segments 40 and 42 need only be cut, and a new hole can be drilled at the same or proximal area to where hole 24 was initially drilled.

Although the preferred embodiments of the invention have been illustrated and described in detail, it will be readily apparent to those skilled in the art that various modifications may be made therein without departing from the spirit of the invention or from the scope of the appended claims.

CLAIMS

What is claimed is:

- 5 1. A suture anchor (20) comprising:
a sterile anchor segment (58) having a first hole (36) and a second hole (38);
wherein said sterile anchor segment (58) is configured to accept a first suture segment
(40) passing through said first hole (36) and a second suture segment (42) passing through
said second hole (38).
- 10 2. A suture anchor (20) as claimed in claim 1 wherein said first suture segment
(40) and said second suture segment (42) form a suture (32).
- 15 3. A suture anchor (20) as claimed in claim 1 wherein said sterile anchor
segment (34) is a first sterile anchor segment (34) and said suture anchor (20) further
comprises:
a second sterile anchor segment (94) having a third hole (96) and a fourth hole (98);
wherein said second sterile anchor segment (94) is configured to accept a first suture
segment (36) passing through said third hole (96) and a second suture segment (42) passing
20 through said fourth hole (98);
- 25 4. A suture anchor (20) as claimed in claim 3 wherein:
a distance (100) between said first hole (36) and said second hole (38) and a distance
(102) between said third hole (96) and said fourth hole (98) are substantially equal;
said first sterile anchor segment (34) is centered about a first axis (112);
said second sterile anchor segment (94) is centered about a second axis (114); and
when said first hole (36) and said third hole (96) are aligned and said second hole (38)
and said fourth hole (98) are aligned, said first axis (112) is offset from said second axis
(114).

-12-

5. A suture anchor (20) as claimed in claim 3 wherein said first sterile anchor segment (34) has a bottom side (108) that is tapered.

6. A suture anchor (20) as claimed in claim 5 wherein said second sterile anchor
5 segment (94) has a top side (110) that is tapered.

7. A suture anchor (20) as claimed in claim 6 wherein:
said first sterile anchor segment (34) has a top side (44);
said second sterile anchor segment (94) has a bottom side (106) ; and
10 said top side (44) of said first sterile anchor segment (34) and said bottom side (106) of said second sterile anchor segment (94) are substantially parallel when said bottom side (108) of said first sterile anchor segment (34) and said top side (110) of said second sterile anchor segment (94) are adjacent.

8. A suture anchor (20) as claimed in claim 1 wherein said sterile anchor
15 segment (34) has rounded corners.

9. A suture anchor (20) as claimed in claim 1 wherein said sterile anchor
segment (34) has a groove (48) configured to accept one of said first suture segment (40) and
20 said second suture segment (42).

10. A suture anchor (20) as claimed in claim 1 wherein said sterile anchor
segment (34) has a groove (48) configured to permit fluid flow from a spongy bone (22") to a
cortical bone (22').
25

11. A suture anchor inserting device (58) for inserting a suture anchor (20) inside
a bone (22) comprising:
a positioning unit (60) configured to hold said suture anchor (20); and
a deployment device (62) configured to push said suture anchor (20) held by
30 said positioning unit (60) from said positioning unit (60) into said bone (22);

-13-

wherein said suture anchor (20) is aligned with an axis (92) when held in said positioning unit (60) and said deployment device (62) causes said suture anchor (20) to rotate from said axis (92).

5 12. A suture anchor inserting device (58) as claimed in claim 11 wherein said positioning unit (60) is configured to hold said suture anchor while permitting rotation of said suture anchor (20) while said deployment device (62) pushes said suture anchor (20).

10 13. A suture anchor inserting device (58) as claimed in claim 11 wherein said deployment device (62) pushes said suture anchor (20) from said positioning unit (60) at a point (86) off-center of said suture anchor (20).

15 14. A suture anchor inserting device (58) as claimed in claim 13 wherein:
said positioning unit (60) further comprises a suture anchor holder (68) having an open side (80) and a blocked side (82), said suture anchor holder (68) configured to hold said suture anchor (20); and

said point (86) is selected to encourage rotation of a leading edge (88) of said suture anchor (20) away from said blocked side (82).

20 15. A suture anchor inserting device (58) as claimed in claim 11 wherein:
said deployment device (62) has an end (76) that contacts said suture anchor (20) at a point (86); and
said positioning unit (60) has an open side (80) and a blocked side (82);
wherein said point (86) is proximal to said blocked side (82).

25 16. A suture anchor inserting device (58) as claimed in claim 11 wherein said positioning unit (60) further comprises:
a suture anchor holder (68) having an edge (90), said suture anchor holder (68) configured to:

30 hold said suture anchor (20) and release said suture anchor (20) when said suture anchor (20) is pushed by said deployment device (62); and

-14-

position said suture anchor (20) inside said bone (22) when said suture anchor (20) touches said edge (90) after said suture anchor (20) is released from said positioning unit (60).

5 17. A method of using a suture anchor (20) comprising:
 forming a hole (24) in a bone (22), said bone (22) comprising a spongy bone
(22") and a cortical bone (22');
 inserting said suture anchor (20) within said spongy bone (22") such that said
suture anchor (20) does not extend into said cortical bone (22');
10 applying tension to a first suture segment (40) and a second suture segment
(42) to position said suture anchor (20) such that said suture anchor (20) spans said hole (24).

 18. A method of using a suture anchor (20) as claimed in claim 17 wherein said
inserting activity further comprises:
15 placing said suture anchor (20) in a suture anchor inserting device (58);
 inserting said suture anchor inserting device (58) within said cortical bone
(22') through said hole (24); and
 pushing said suture anchor (20) out of said suture anchor inserting device (58)
such that no portion of said suture anchor (20) extends into said cortical bone (22').

20 19. A method of using a suture anchor (20) as claimed in claim 18 wherein said
applying activity further comprises:
 pulling said suture anchor (20) to said suture anchor inserting device (58) such
that said suture anchor (20) is offset from an axis (92) aligned with an axis (56) of said hole
25 (24); and
 extracting said suture anchor inserting device (58) such that said suture
anchor (20) spans said hole (24).

 20. A method of using a suture anchor (20) as claimed in claim 18 wherein said
30 inserting activity further comprises:
 holding said suture anchor (20) in a positioning unit (60); and

-15-

pushing said suture anchor (20) from said positioning unit (60) into said bone (22) with a deployment device (62);

wherein said suture anchor (20) is aligned with an axis (92) when held in said positioning unit (60) and said deployment device (62) causes said suture anchor (20) to rotate
5 from said axis (92).

21. A method of using a suture anchor (20) as claimed in claim 20 wherein said deployment device (62) is further configured to encourage said suture anchor (20) to rotate to a direction perpendicular to said axis (92).

10 22. A suture anchor system (84) comprising:
a suture anchor (20) comprising:

an sterile anchor segment (34) having a first hole (36) and a second hole (38);
wherein said sterile anchor segment (34) is configured to accept a first suture segment
15 (40) passing through said first hole (36) and a second suture segment (42) passing through
said second hole (38); and

a suture anchor inserting device (58) comprising:
a positioning unit (60) configured to hold said suture anchor (20); and
a deployment device (62) configured to push said suture anchor (20)
20 held by said positioning unit (60) from said positioning unit (60) into a bone (22).

23. A suture anchor system (84) as claimed in claim 22 wherein said first suture segment (40) and said second suture segment (42) form a suture (32).

25 24. A suture anchor system (84) as claimed in claim 22 wherein said sterile anchor segment (34) is a first sterile anchor segment (34), said suture anchor (20) further comprises:
a second sterile anchor segment (94) having a third hole (96) and a fourth hole (98);
wherein said second sterile anchor segment (94) is configured to accept a first suture segment (40) passing through said third hole (96) and a second suture segment (42) passing
30 through said fourth hole (98);

wherein:

-16-

said first sterile anchor segment (34) is centered about a first axis (112);
said second sterile anchor segment (94) is centered about a second axis (114);
a linear distance (100) between said first hole (36) and said second hole (38)
and a linear distance (102) between said third hole (96) and said fourth hole (98) are
5 substantially equal; and

when said first hole (36) and said third hole (96) are aligned and said second
hole (38) and said fourth hole (98) are aligned, said first axis (112) is offset from said second
axis (114).

10 25. A suture anchor inserting device (58) as claimed in claim 22 wherein said
deployment device (62) pushes said suture anchor (20) from said positioning unit (60) at a
point (86) off-center of said suture anchor (20).

15 26. A suture anchor inserting device (58) as claimed in claim 25 wherein said
point (86) encourages rotation of a leading edge (88) of said suture anchor (20) away from a
blocked side (82) of said suture anchor (20) of said positioning unit (60).

20 27. A suture anchor inserting device (58) as claimed in claim 22 wherein:
said deployment device (62) has an end (76) that contacts said suture anchor
(20) at a point (86); and
said positioning unit (60) has an open side (80) and a blocked side (82);
wherein said point (86) is proximal to said blocked side (82).

25 28. A suture anchor inserting device (58) as claimed in claim 22 said positioning
unit (60) further comprising:
an open end (80) having an edge (90), said open end (80) configured to:
hold said suture anchor (20) and release said suture anchor (20) when
said suture anchor (20) is pushed by said deployment device (62); and
position said suture anchor (20) inside said bone (22) when said suture
30 anchor (20) touches said edge (90) after said suture anchor (20) is released from said
positioning unit (60).

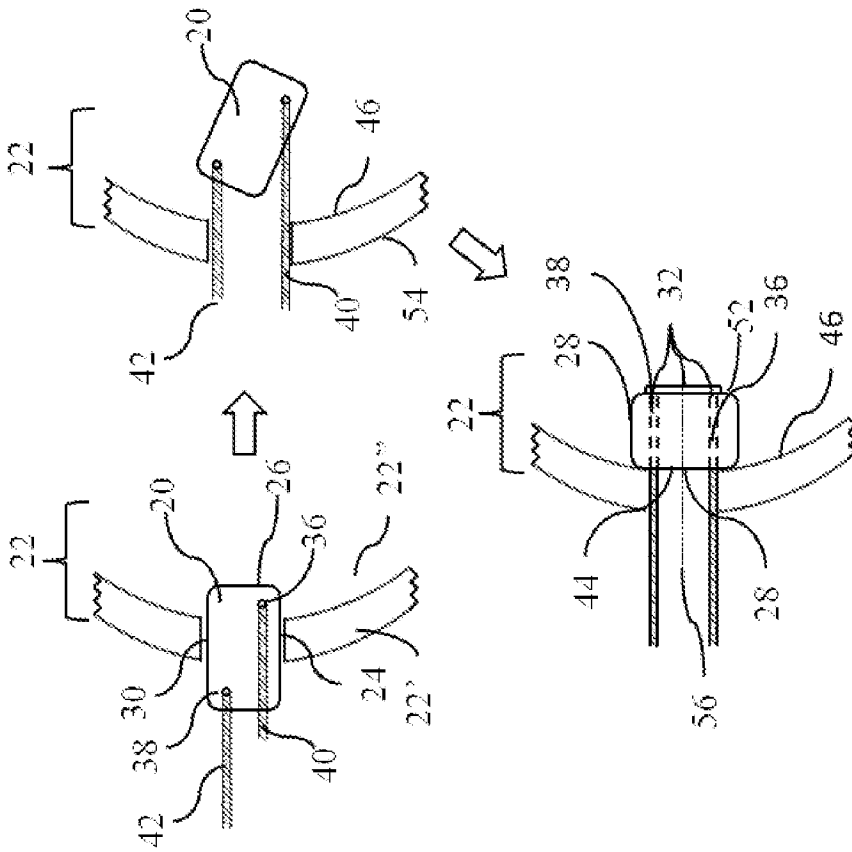

FIG. 1

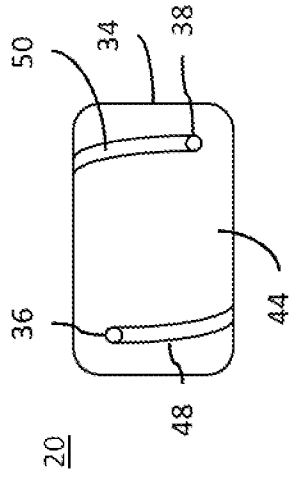

FIG. 2

FIG. 3

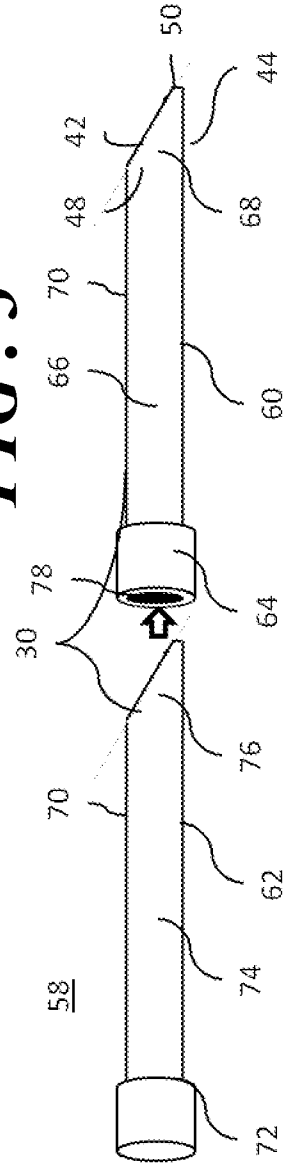

FIG. 3

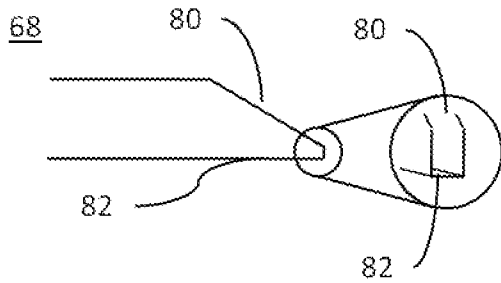

FIG. 4

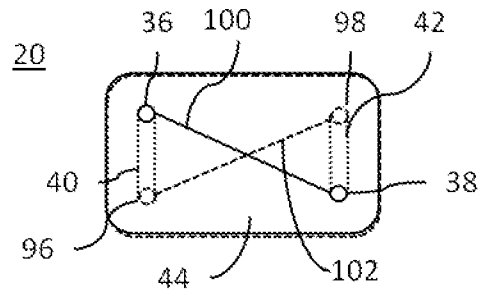
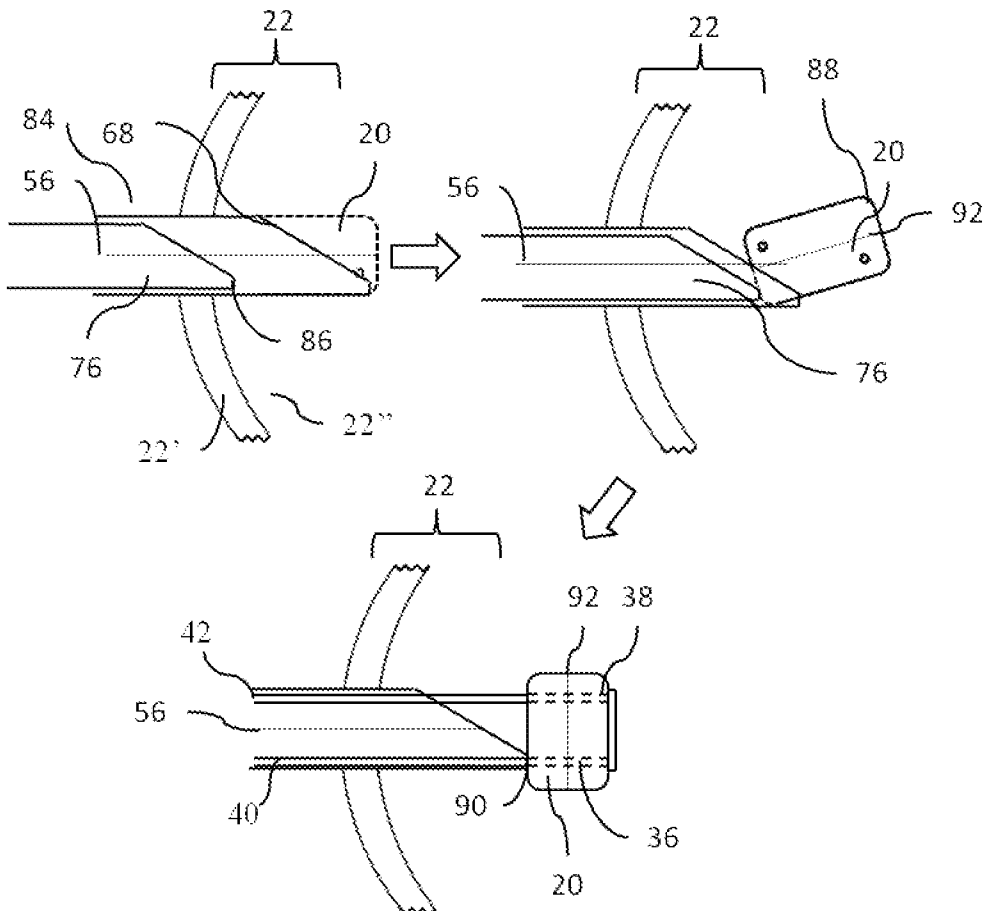

FIG. 6

FIG. 5



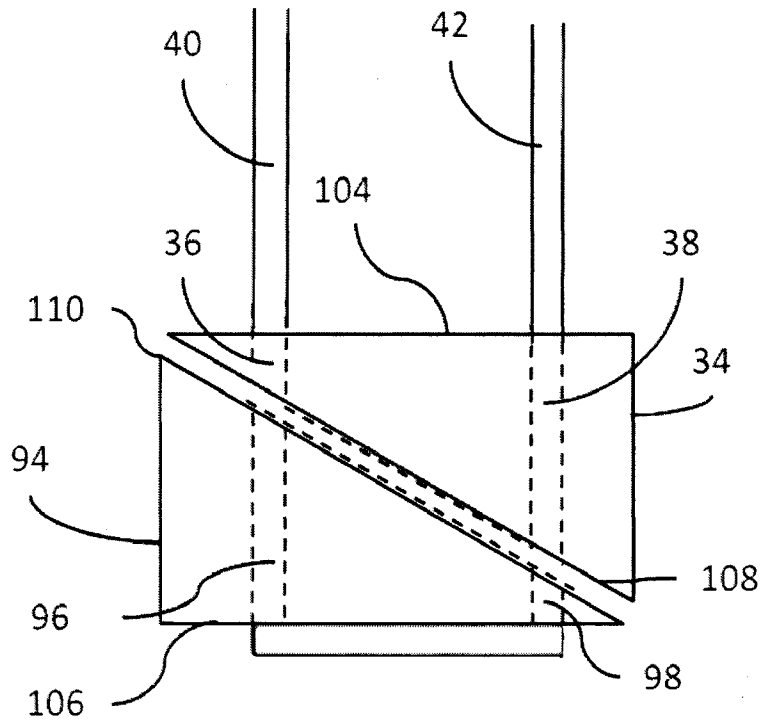

FIG. 7

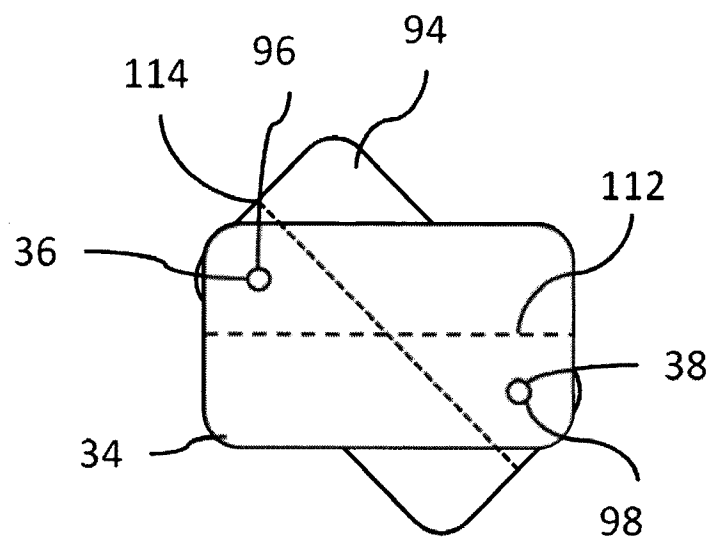

FIG. 8

INTERNATIONAL SEARCH REPORT

International application No.

PCT/US2010/046579

A. CLASSIFICATION OF SUBJECT MATTER

IPC(8) - A61B 17/04 (2010.01)

USPC - 606/232

According to International Patent Classification (IPC) or to both national classification and IPC

B. FIELDS SEARCHED

Minimum documentation searched (classification system followed by classification symbols)

IPC(8) - A61B 17/04, 19/00 (2010.01)

USPC - 606/60, 69, 72, 73, 75, 232; 623/13

Documentation searched other than minimum documentation to the extent that such documents are included in the fields searched

Electronic data base consulted during the international search (name of data base and, where practicable, search terms used)

PatBase, Google Scholar

C. DOCUMENTS CONSIDERED TO BE RELEVANT

Category*	Citation of document, with indication, where appropriate, of the relevant passages	Relevant to claim No.
X --- Y	US 6,117,161 A (LI et al) 12 September 2000 (12.09.2000) entire document	1-10 ----- 22-28
X --- Y	US 5,845,645 A (BONUTTI) 08 December 1998 (08.12.1998) entire document	11-21 ----- 22-28
A	US 5,403,348 A (BONUTTI) 04 April 1995 (04.04.1995) entire document	1-28
A	US 5,207,679 A (LI) 04 May 1993 (04.05.1993) entire document	1-28

 Further documents are listed in the continuation of Box C.

* Special categories of cited documents:

"A" document defining the general state of the art which is not considered to be of particular relevance

"E" earlier application or patent but published on or after the international filing date

"L" document which may throw doubts on priority claim(s) or which is cited to establish the publication date of another citation or other special reason (as specified)

"O" document referring to an oral disclosure, use, exhibition or other means

"P" document published prior to the international filing date but later than the priority date claimed

"T" later document published after the international filing date or priority date and not in conflict with the application but cited to understand the principle or theory underlying the invention

"X" document of particular relevance; the claimed invention cannot be considered novel or cannot be considered to involve an inventive step when the document is taken alone

"Y" document of particular relevance; the claimed invention cannot be considered to involve an inventive step when the document is combined with one or more other such documents, such combination being obvious to a person skilled in the art

"&" document member of the same patent family

Date of the actual completion of the international search

12 November 2010

Date of mailing of the international search report

29 NOV 2010

Name and mailing address of the ISA/US

Mail Stop PCT, Attn: ISA/US, Commissioner for Patents

P.O. Box 1450, Alexandria, Virginia 22313-1450

Facsimile No. 571-273-3201

Authorized officer:

Blaine R. Copenheaver

PCT Helpdesk: 571-272-4300

PCT OSP: 571-272-7774