



(86) Date de dépôt PCT/PCT Filing Date: 2002/08/12  
 (87) Date publication PCT/PCT Publication Date: 2003/03/13  
 (85) Entrée phase nationale/National Entry: 2004/02/09  
 (86) N° demande PCT/PCT Application No.: US 2002/025186  
 (87) N° publication PCT/PCT Publication No.: 2003/020590  
 (30) Priorité/Priority: 2001/08/13 (09/928,936) US

(51) Cl.Int.<sup>7</sup>/Int.Cl.<sup>7</sup> B65B 5/00  
 (71) Demandeur/Applicant:  
DSD COMMUNICATIONS, INC., US  
 (72) Inventeurs/Inventors:  
DHARSSI, FATEHALI T., US;  
KLINEFELTER, DALE LEE, US;  
MARSHALL, BROAM, US;  
NOEL, RAYMOND E., JR., US  
 (74) Agent: OYEN WIGGS GREEN & MUTALA

(54) Titre : SYSTEME ET PROCEDE D'INCLUSION D'ENCARTS AVEC DES PRODUITS EN D'EMBALLAGE  
AUTOMATISE

(54) Title: SYSTEM AND METHOD FOR INCLUDING INSERTS WITH GOODS DURING AUTOMATED PACKAGING

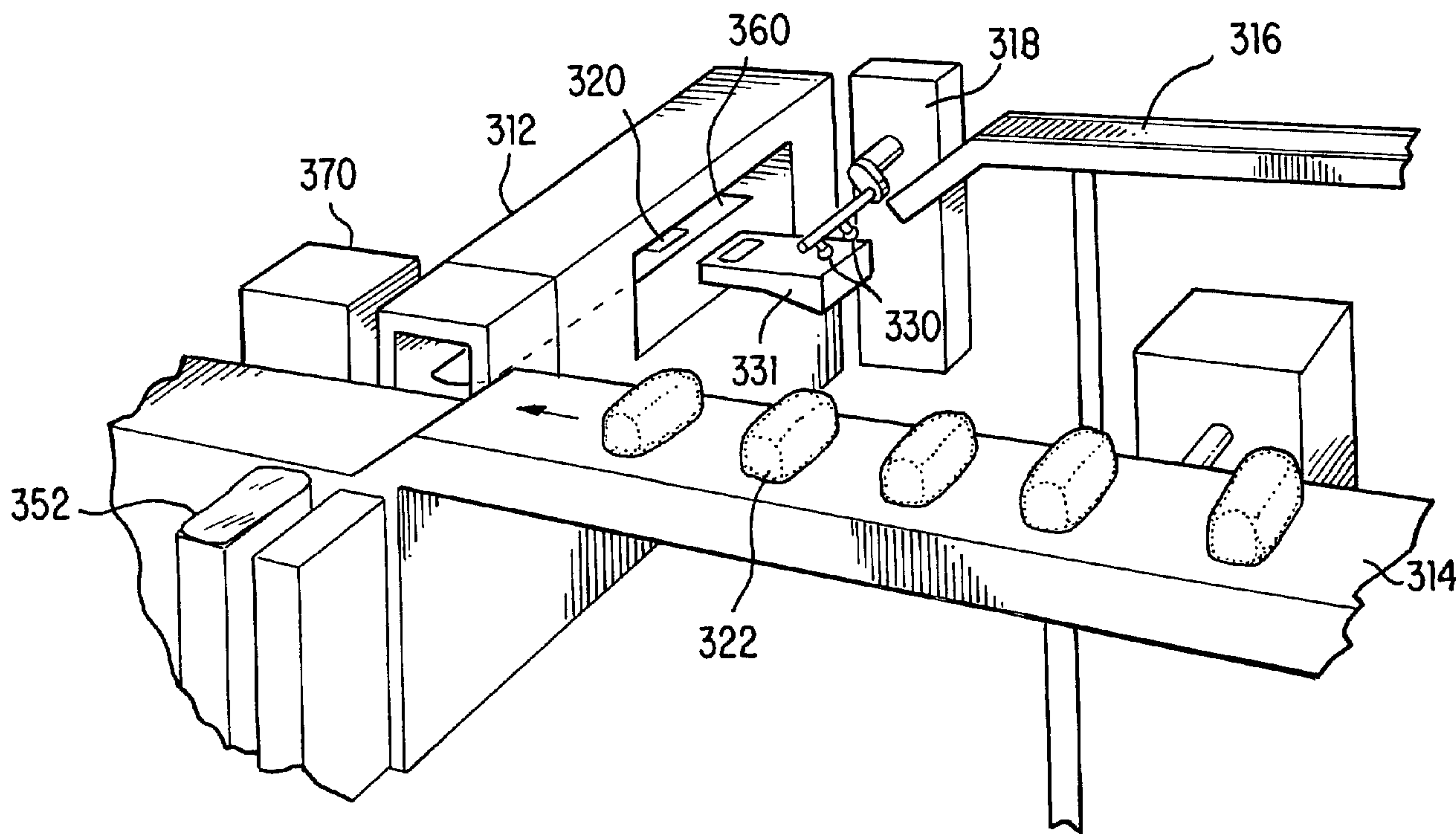

(57) Abrégé/Abstract:

An insert delivery system for use with an automated packaging machine. The system is used to include coupons (320) and the like with products (322) being automatically packaged, such as sliced loaf bread. The system comprises an insert delivery tray, cart conveyor (316), or carousel and magazine combination, a feeder mechanism (331), and an insert placer (318) configured to select an insert (320) from the tray, conveyor (316), or magazine. The insert placer (318) includes a vacuum system (330) and moves linearly. The feeder mechanism (331) is position either perpendicular or parallel to the scoop assembly (360), so as to feed an insert (320) onto the scoop assembly (360) at various points along the path of the scoop assembly.

## (12) INTERNATIONAL APPLICATION PUBLISHED UNDER THE PATENT COOPERATION TREATY (PCT)

(19) World Intellectual Property Organization  
International Bureau



(43) International Publication Date  
13 March 2003 (13.03.2003)

PCT

(10) International Publication Number  
**WO 03/020590 A1**

- (51) International Patent Classification<sup>7</sup>: **B65B 5/00**
- (21) International Application Number: PCT/US02/25186
- (22) International Filing Date: 12 August 2002 (12.08.2002)
- (25) Filing Language: English
- (26) Publication Language: English
- (30) Priority Data:  
09/928,936 13 August 2001 (13.08.2001) US
- (71) Applicant: **DSD COMMUNICATIONS, INC.** [US/US]; Suite 3200, 1001 Fourth Avenue Plaza, Seattle, WA 98154 (US).
- (72) Inventors: **DHARSSI, Fatehali, T.**; 1001 Fourth Avenue Plaza, Suite 3200 British Columbia V6M1N1, Seattle, WA 98154 (US). **KLINEFELTER, Dale, Lee**; 1203 E. Walnut Street, Rogers, AR 72756 (US). **MARSHALL, Broam**; 13053 Rosario Road, Garfield, AR 72732 (US). **NOEL, Raymond, E., Jr.**; 3 Aberdeen Lane, Bella Vista, AK 72715 (US).
- (74) Agents: **ZAITLEN, Richard, H.** et al.; Pillsbury Winthrop LLP, Suite 2800, 725 South Figueroa Street, Los Angeles, CA 90017-5406 (US).
- (81) Designated States (*national*): AE, AG, AL, AM, AT, AU, AZ, BA, BB, BG, BR, BY, BZ, CA, CH, CN, CO, CR, CU, CZ, DE, DK, DM, DZ, EC, EE, ES, FI, GB, GD, GE, GH, GM, HR, HU, ID, IL, IN, IS, JP, KE, KG, KP, KR, KZ, LC, LK, LR, LS, LT, LU, LV, MA, MD, MG, MK, MN, MW, MX, MZ, NO, NZ, OM, PH, PL, PT, RO, RU, SD, SE, SG, SI, SK, SL, TJ, TM, TN, TR, TT, TZ, UA, UG, UZ, VN, YU, ZA, ZM, ZW.
- (84) Designated States (*regional*): ARIPO patent (GH, GM, KE, LS, MW, MZ, SD, SL, SZ, TZ, UG, ZM, ZW), Eurasian patent (AM, AZ, BY, KG, KZ, MD, RU, TJ, TM), European patent (AT, BE, BG, CH, CY, CZ, DE, DK, EE, ES, FI, FR, GB, GR, IE, IT, LU, MC, NL, PT, SE, SK, TR), OAPI patent (BF, BJ, CF, CG, CI, CM, GA, GN, GQ, GW, ML, MR, NE, SN, TD, TG).
- Published:**  
— with international search report

[Continued on next page]

(54) Title: SYSTEM AND METHOD FOR INCLUDING INSERTS WITH GOODS DURING AUTOMATED PACKAGING

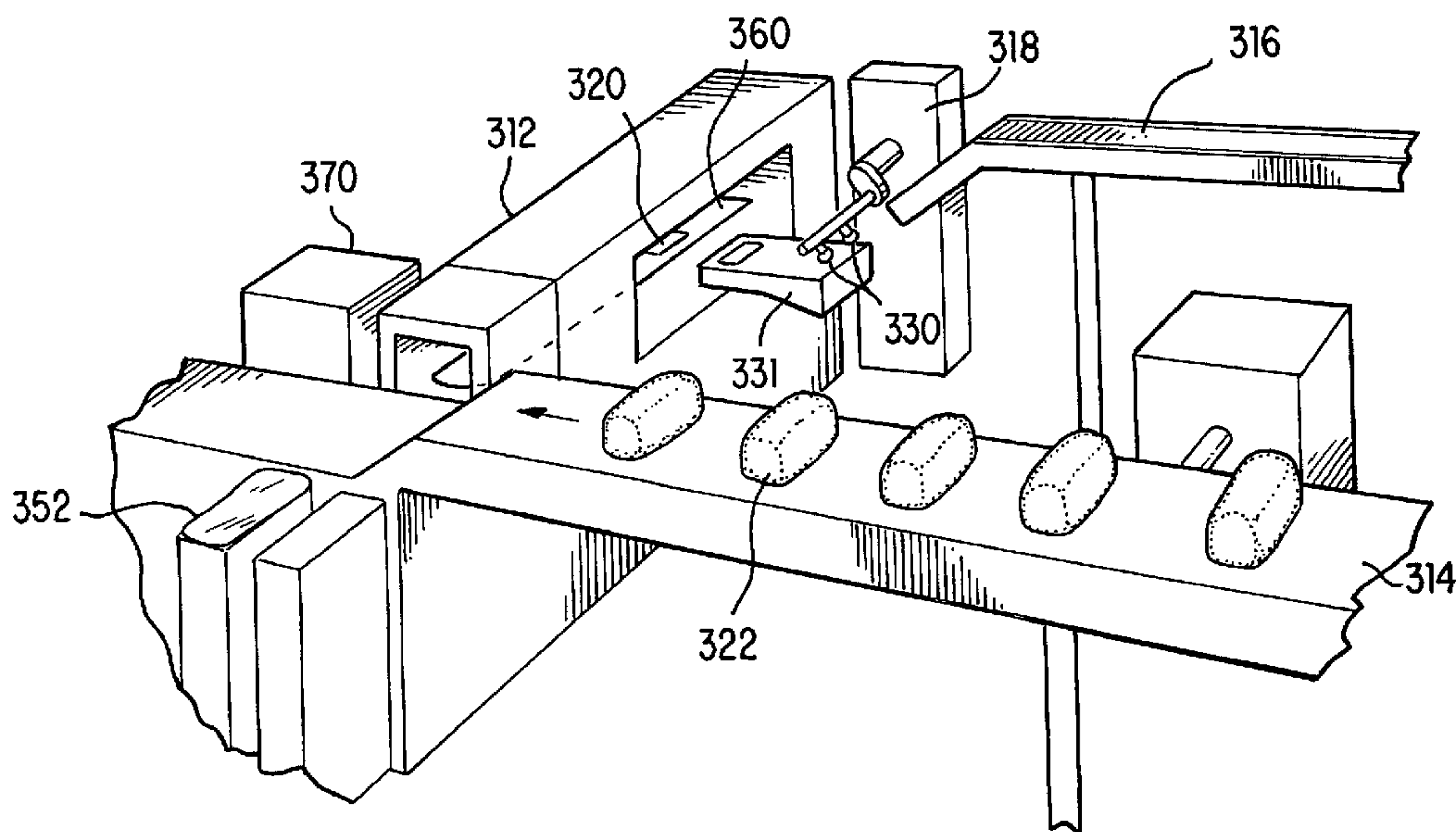

(57) Abstract: An insert delivery system for use with an automated packaging machine. The system is used to include coupons (320) and the like with products (322) being automatically packaged, such as sliced loaf bread. The system comprises an insert delivery tray, cart conveyor (316), or carousel and magazine combination, a feeder mechanism (331), and an insert placer (318) configured to select an insert (320) from the tray, conveyor (316), or magazine. The insert placer (318) includes a vacuum system (330) and moves linearly. The feeder mechanism (331) is position either perpendicular or parallel to the scoop assembly (360), so as to feed an insert (320) onto the scoop assembly (360) at various points along the path of the scoop assembly.

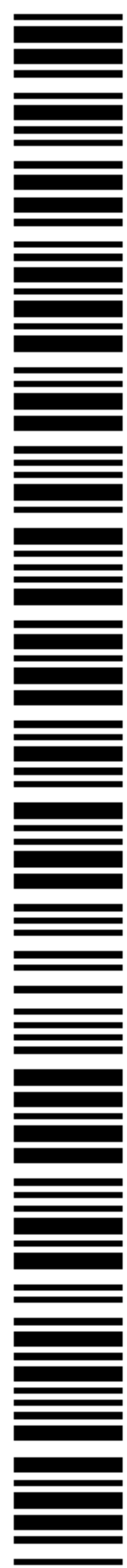

WO 03/020590 A1

**WO 03/020590 A1**

---



*For two-letter codes and other abbreviations, refer to the "Guidance Notes on Codes and Abbreviations" appearing at the beginning of each regular issue of the PCT Gazette.*

SYSTEM AND METHOD FOR INCLUDING INSERTS WITH GOODS DURING  
AUTOMATED PACKAGING

**RELATED APPLICATION DATA**

5 This is a continuation-in-part of Serial No. 09/780,950, filed on February 9, 2001, which is a continuation-in-part of Serial No. 09/632,900, filed on August 7, 2000.

**BACKGROUND OF THE INVENTION**

Field of the Invention

10 The present invention relates to the field of automated packaging and specifically to the delivery of inserts to be automatically included with a product being packaged.

Description of Related Art

Automated bread packaging devices are widely used to wrap loaf bread in plastic. However, when packaging bread, it can be desirable to include coupons, promotional material, or other printed material directed at the purchaser of the bread. Prior-art systems for inserting this material into the package have generally been deficient. Coupons and the like can be added manually, after the bread has been placed in the wrapper and prior to closure, but this is labor intensive and time consuming. Similar problems characterize systems that place the coupons into the bag before wrapping the bread. Prior-art automated means for inserting a coupon into the bread package have required relatively complicated and expensive machinery and suffer from reliability problems. Further, these prior-art systems often require significant modification or even replacement of otherwise useful automated packaging machines.

25 Accordingly, what has been needed is an automated system for including inserts in packaged bread and other similar commodities. There is also a need for such an automated system that easily integrates with existing automated packaging machines. This invention satisfies these and other needs.

**BRIEF DESCRIPTION OF THE DRAWINGS**

30 FIG. 1 is a schematic view of the insert delivery system of an embodiment of the invention in use with an automated bread packaging machine;

FIGS. 2A and 2B is a view of the insert delivery system of an embodiment of the invention oriented adjacent the infeed of the automated bread packaging machine;

FIG. 3 is a detail top view of the insert delivery system of an embodiment of the invention;

FIG. 4 is a detail side view of the insert delivery system of an embodiment of the invention;

FIG. 5 shows an alternate embodiment of the invention comprising two insert delivery trays;

FIGS. 6-9 are schematic views of a bread packaging system suitable for use with embodiments of the invention, showing a loaf of bread and an insert being wrapped;

FIG. 10 is a schematic view of an embodiment of the invention configured to automatically package a three-fold insert;

FIG. 11 is a front view of the embodiment of the invention shown in FIG. 10;

FIG. 12 is a schematic view of a three-fold insert of an embodiment of the invention around a packaged item;

FIG. 13 is a schematic view of an alternative embodiment of the invention;

FIG. 14 is a schematic view of an alternative embodiment of the invention;

FIG. 15 is a schematic view of the lower bread scoop of the embodiment shown in FIG. 13;

FIG. 16A is a schematic view of a lower bread scoop, modified according to an alternative embodiment of the invention;

FIG. 16B is a schematic cross-sectional view of the relationship between a scoop and a feeder mechanism according to an embodiment of the invention;

FIGS. 17A-C show the lower bread scoop of FIG. 16A, modified according to an alternative embodiment of the invention;

FIG. 17 D shows an alternative embodiment of the stop bar of FIGS. 17A-C; and

FIG. 18 is a schematic view of an alternative embodiment of the invention.

### DETAILED DESCRIPTION OF THE INVENTION

This invention is an insert delivery system for use with an automated product packager having an infeed to convey a product to be packaged. As is explained in further detail below, it is critical that the movement of the various components of the system be synchronized, such that each component can be positioned in the proper location at the appropriate time. In general, this is accomplished by: (1) placing sensors in critical locations within the components of the system, as well as on other devices that operate in conjunction with the system; (2) providing information gathered from the sensors as input into a control mechanism, such as, a programmable logic controller (PLC), or other similar device (e.g., a digital computer system with programmable memory); and (3) using the PLC or other similar device to activate the various components of the system at the appropriate time. It is noted that, in the description that follows, the words “wrapper” and “bag” are used interchangeably.

In one embodiment, the system comprises an insert delivery tray configured to present an insert to an insert placer, wherein the insert delivery system is configured so that the insert placer delivers the insert onto the infeed upstream of the product. The insert may be coupons, promotional material, or the like. The system is particularly suited to automatic packagers of the type used to wrap bread. In a preferred embodiment, the insert placer has an arm that cycles between an insert pick-up position and an insert drop-off position, with an insert holder that is adjacent the insert delivery tray and secures the insert when the arm is in the insert pick-up position and is adjacent the infeed and releases the insert when the arm is in the insert drop-off position. More preferably, the insert holder comprises a vacuum system.

In an alternative embodiment, the system comprises an insert delivery tray that is configured to present an insert to an insert placer. The insert placer, in turn, delivers the insert to a feeder mechanism (alternatively referred to as a “direct insert device”) that is disposed adjacent, and above, a distal portion of an infeed conveyor. The infeed mechanism deposits the insert onto a scoop that has been advanced, or extended, towards a forward position, in order to receive the product (e.g., bread). In a preferred embodiment, the scoop has two sets of air apertures, wherein each set is preferably arranged in a line, and wherein at one selected time the air apertures provide a suction vacuum for securely retaining the insert that is placed on the scoop, and at a second

selected time the air apertures provide blow-off air, which helps separate the insert from the scoop before the scoop slides back to its retracted position.

In another embodiment, the system comprises an insert card conveyor that is configured to present an insert to an insert placer, wherein the insert placer delivers the insert to a feeder  
5 mechanism which, in turn, deposits the insert onto a fully-retracted scoop before the scoop receives the product, e.g., a loaf of bread. In a preferred embodiment, the scoop has two sets of air apertures, wherein each set is preferably arranged in a line, and wherein at one selected time the air apertures provide a suction vacuum for securely retaining the insert that is placed on the  
10 scoop, and at a second selected time the air apertures provide blow-off air, which helps separate the insert from the scoop before the scoop slides back to its retracted position, where it picks up another insert.

In yet another embodiment, the system comprises a scoop which has an additional lower compartment for carrying an insert. When in the fully-retracted position, an insert is deposited  
15 into the compartment, which is equipped with a means for driving the insert out from the distal end of the compartment once the scoop has been advanced (i.e., extended). Preferably, once the scoop has received a loaf of bread and extended into a wrapper, a plunger is used to push the insert into the wrapper, so that the insert will lie underneath the bread once the latter has been fully placed into the wrapper. Alternatively, a stop pin, a bar, or other similar member may be positioned perpendicularly through the scoop and lower compartment. In this way, as the scoop is  
20 being retracted, the insert is automatically expelled from the lower compartment, thus obviating the need for a plunger.

In yet another embodiment, the system comprises an insert deposition mechanism (e.g., a plurality of feeder mechanisms, each of which delivers a separate insert, or a feeder mechanism that is capable of delivering more than one insert at a time) whereby one or more inserts may be  
25 delivered onto the scoop assembly through a line of insertion that is parallel to the longitudinal axis of the scoop. Preferably, when more than one insert is being deposited on to the scoop, the inserts are delivered substantially simultaneously such that both inserts are included with the product being packaged. Thus, for example, when two inserts are to be included with a loaf of bread, an insert can be included on each of two different sides of the loaf, so as to generate a  
30 bread package with two separate inserts.

The invention described herein also includes an ejection mechanism whose operation is

synchronized with the operation of the insert delivery system and the automated product packager. When activated, the ejection mechanism utilizes air pressure, a mechanical device (e.g., a plunger), an electro-mechanical device, or other similar means to ensure that inserts that have been misfed, are stuck, or otherwise obstruct the continuous operation of the system are removed. Regardless of the actual mechanism used, however, the ejection mechanism is configured such that the operation of the mechanism does not interrupt the operation of the remainder of the system, i.e., the bagging of the bread.

Certain embodiments of the invention further comprise a second delivery tray, or insert card conveyor, having a different insert, wherein the delivery trays or insert card conveyors are movable so that the insert placer can access either tray or conveyor depending upon which insert is desired. In other embodiments of the invention, the delivery tray or insert card conveyor is configured to accommodate a three-fold insert that wraps around the bottom and sides of the packaged item.

In yet other embodiments, the delivery tray, or insert card conveyor, may be a carousel and magazine assembly. Here, a rotating carousel is equipped with a plurality of vertical magazines, each of which holds a set of inserts. Each magazine is also equipped with sensors, so that, each time an insert is picked up by an insert placer device, a magazine insert advancement mechanism is activated to move the stack of inserts up in the vertical direction, so as to present the next insert to the insert placer device. When the inserts in one magazine are depleted, a sensor activates a servo motor, which in turn rotates the carousel in order to present the next magazine to the insert placer device. In addition, in this embodiment, the suction cups of the insert placer device move in two linear directions between a pick-up and a drop-off position.

In embodiments where a plurality of inserts are delivered to the scoop assembly, the insert deposition mechanism (e.g., a plurality of feeder mechanisms, or a single, modified feeder mechanism, as discussed above) may be adapted to receive an insert from each of a plurality of magazines which may, in turn, be positioned on either the same, or separate carousels.

The invention also includes methods of using an insert delivery system with an automated product packager. Generally, a method according to the invention comprises providing an automated product packager having an infeed and an insert delivery system having a first insert delivery tray configured to present a first insert to an insert placer, wherein the insert delivery system is configured so that the insert placer delivers the insert onto the infeed upstream of the

product. The product is advanced along the infeed and an insert holder on the insert placer is operated to select and secure the insert from the delivery tray. The insert placer is then moved so that the holder is adjacent the infeed and the insert is released from the holder. This deposits the insert on the infeed upstream of the advancing product. The automated packager may then wrap  
5 the product and the insert.

Alternatively, a method for including inserts with goods during automated packaging includes providing an automated product packager (e.g., bread-bag packager) having an infeed and an insert delivery system having a first insert card conveyor configured to present a first insert to an insert placer, wherein the insert delivery system is configured so that the insert placer  
10 delivers the insert to a feeder mechanism. The feeder mechanism deposits the insert onto a bread scoop just before the scoop is advanced from its retracted position to receive the product (e.g., a loaf of bread) from the infeed conveyor. The loaded bread scoop is then advanced, receives the loaf of bread, deposits the loaf and the insert into a bag, and then retracts for another cycle. The automated packager may then wrap the product and the insert.

15 Alternatively, the feeder mechanism may be provided in a position above the scoop when the scoop is in its extended position, wherein the scoop receives the insert after it has been extended, but before it receives the loaf of bread.

Additionally, a method for including inserts with goods during automated packaging may include providing a scoop with an additional compartment underneath the scoop, depositing an  
20 insert in the compartment when the scoop is in the retracted position, advancing the scoop to receive the loaf of bread, advancing the distal ends of the scoop and compartment into a wrapper, and simultaneously depositing the insert and the bread into the wrapper before the scoop-and-compartment assembly is retracted.

Alternatively, a method for including inserts with goods during automated packaging may  
25 include providing one or more insert deposition mechanisms for delivering one or more inserts onto the scoop assembly through a line of insertion that is parallel to the longitudinal axis of the scoop. The delivery, or deposition, of the inserts is performed substantially simultaneously such that all of the inserts are included with the product being packaged. Thus, for example, when the product is a loaf of bread, an insert can be included on one or more sides of the loaf, so as to  
30 generate a bread package with one or more separate inserts.

Figure 1 shows an automated bread packaging station 10 comprising a bread packaging machine 12, an infeed conveyor 14, an insert delivery tray 16 and an insert placer 18, configured to include an insert 20 with individual bread loaves 22 as they are wrapped. Bread packaging machine 12 generally is conventionally known in the art and its function in conjunction with the invention is described below (e.g., with reference to Figures 6-9). Infeed conveyor 14 is also similar to those in conventional use and utilizes a driven flight system to urge the individual loaves 22 along a smooth table, although other conventional means such as conveyor belts may also be used.

Insert placer 18 cycles between the two positions shown in Figures 2A and 2B to select an insert 20 from delivery tray 16 and then place it just upstream of the advancing loaf 22. In a preferred embodiment, insert placer 18 comprises rotating drive plate 24 having arm 26. Stems 28, each carrying a vacuum cup 30, are generally perpendicular to arm 26. The system is configured so that in the position shown in Figure 2A, the vacuum cups are brought into contact with insert 20 which is accessible through the open end of delivery tray 16. The system applies a vacuum to cups 30 through hoses 32 and stems 28, thus securing insert 20 to the cups 30. Rotation of drive plate 24 swings the arm 26 and stems 28 to the insert drop-off position shown in Figure 2B. The vacuum is released so that insert 20 remains on infeed conveyor 14 when insert delivery machine 18 swings back to the insert pick-up position of Figure 2A. Insert 20 is carried by the advancing loaf 22 to packaging machine 12. Preferably, the insert placement motion is triggered by sensing the presence of a loaf 22 at the appropriate location on infeed conveyor 14 (e.g., via a sensor placed at position 14a, that, for illustrative purposes, may be about 3/4 of the way along the conveyor 14 shown in Figure 2B). The sensing may be accomplished by optical, mechanical, or any other suitable means.

In a preferred embodiment, insert delivery tray 16 is generally U-shaped and about six inches wide and three inches high. In this embodiment, a twelve-inch end portion of tray 16 adjacent insert placer 18 angles downward at about 30 degrees. In other embodiments, the dimensions of tray 16 generally should accommodate the size of insert 20, and the configuration of tray 16 may be adapted to insert placer 18, packaging machine 12, and infeed conveyor 14.

Figures 3 and 4 show, partially in section, further details of the embodiment shown in Figures 2A and 2B. Figure 3 is a top view showing the motion between the insert pick-up position and the drop-off position (shown in phantom). Arm 26 is driven by pinion gear 34 and

ring gear 36 via servo motor 38. A counter weight 40 may be positioned opposite arm 26 to decrease the load on the servo. Similarly, Figure 4 is a side view showing the motion between the drop-off position and the pick-up position (shown in phantom).

Other embodiments of the invention may employ different insert holding and delivery mechanisms. For example, the inserts may be presented by the delivery tray in an edgewise manner. In such embodiments, the insert holder generally comprises an articulated gripper as opposed to the vacuum cup arrangement. It is also noted that delivery motions other than the rotation described herein may be used. Further, the insert delivery tray may be configured to simply release single inserts, allowing gravity to drop them into position ahead of the advancing loafs.

In yet other embodiments, the delivery tray may be replaced by a carousel and magazine assembly. Here, a rotating carousel is equipped with a plurality (typically, between four and eight) of vertical magazines, each of which holds a set of inserts which are placed horizontally in the magazine and stacked in a vertical arrangement. Each magazine is also equipped with sensors, so that, each time an insert is picked up by an insert placer device, a magazine insert advancement mechanism is activated to move the stack of inserts up in the vertical direction (via, e.g., a lead-screw-and-knot assembly, or an air-cylinder-and-brake assembly), so as to present the next insert to the insert placer device. When the inserts in one magazine are depleted, a sensor activates a servo motor, which in turn rotates the carousel in order to present the next magazine to the insert placer device.

In addition, the sensors are configured to detect inserts that are stuck together. In such a situation, the inserts are still delivered to the feeder mechanism. However, having been alerted by the sensors, the feeder simply ejects the stuck inserts away, rather than deliver them to the scoop assembly.

One or more additional bar code readers can be mounted on the carousel and magazine assembly to determine whether the identity of the insert is proper for the particular type or brand of bread being wrapped. In addition, since the bar code on each insert identifies the chain store (e.g., Albertson's, Safe Way, etc.) to which the bag will be delivered, as well as, e.g., the brand of the bread, the bar code readers can also determine whether the correct inserts (e.g., inserts intended to be included in products for Albertson's stores) are being delivered to the correct bags (e.g., bags that will be going to Albertson's stores, and not to Safe Way stores).

The insert placer device comprises suction cups of the kind discussed above, except that, in this embodiment, the cups do not cycle by rotating between a pick-up and a drop-off position. Rather, the suction cup assembly (e.g., the holder, having an arm and one or more suction cups) of the placer device moves in two linear directions. Thus, as an insert is presented atop the stack of inserts in a magazine, suction cups move vertically downwards in a direction that is perpendicular to the plane of the insert, and secure the insert from above; they then move vertically back up. With the insert secured, the suction cup assembly moves in a direction that is parallel to the plane of the insert (i.e., usually horizontally), until it reaches a drop-off position. Here, the suction cup assembly either releases the insert in the drop-off position, or moves vertically down before releasing the insert.

Returning to Figures 1, 2A, and 2B, insert delivery tray 16 preferably presents a stack of individual inserts 20 to delivery machine 18. The stack of inserts may be moved along tray 16 by any suitable mechanism, such as by a spring loaded system. One embodiment employs a conveyor belt to maximize the capacity of the system. Optionally, the invention comprises a plurality of delivery trays 16 and 42 as shown in Figure 5, carrying inserts 20 and 44 respectively (insert placer 18 is not shown for clarity). Trays 16 and 42 slide along rail 46 so that either may be presented to delivery machine 18. In this embodiment, movement of the trays is actuated by hydraulic cylinder 48, although any other suitable mechanism may be employed. Preferably, tray 16 and tray 42 are spaced about 11 inches on center to accommodate a typical insert size of about 3 inches by 6 inches. These dimensions may be adjusted as desired.

In one embodiment of the invention, a sensor 50, such as a bar code reader to scan the UPC label of the wrappers 52, is provided on the packaging machine 12. The information from sensor 50 is used, in conjunction with a control mechanism (such as a PLC, or other similar device), to control cylinder 48 to automate the selection of either inserts 20 or 44 depending upon the product being packaged as indicated by the wrappers 52. This allows the user of the information to tailor the inserts to the expected demographic of the buyer of the particular product, for example.

Figures 6-9 schematically show how packaging machine 12 wraps the loaves 22 and inserts 20 provided by delivery machine 18 and delivery tray 16. In Figure 6, the advancing loaf 22 pushes insert 20 ahead of it. Wrapper 52 is opened, preferably with a jet of air 54, to receive scoop 56. Scoop 56 has upper and lower clamshell members 58 and 60, wherein lower member

60 further comprises a loaf receiving portion 62. As shown in Figure 7, scoop 56 has advanced into opened wrapper 52 and members 58 and 60 have opened to grip wrapper 52 and secure it in an opened position. Loaf receiving portion 62 is positioned to catch insert 20 and then loaf 22 as they are delivered by infeed conveyor 14. A pushing assembly 64 has also advanced to a position adjacent the incoming loaf 22. Figure 8 shows scoop 56 being withdrawn after insert 20 and loaf 22 have been deposited on receiving portion 62. Pushing assembly 64 is kept in its advanced position so that loaf 22 is retained in substantially the same spatial position while withdrawing scoop 56 pulls opened wrapper 52 over the loaf. Since the coefficient of friction of the bread loaf is considerably higher than that of the receiving portion, insert 20 stays with loaf 22 as it is wrapped. Scoop 56 completes its withdrawal and then pushing assembly 64 also withdraws, allowing wrapped loaf 66 to drop onto outfeed conveyor 68 where it will be carried to tying machine 70 for closure. The process is then repeated for the next loaf and insert on the infeed conveyor 14.

As further noted in reference to Figure 6, embodiments of the present invention can also be configured to include a UPC bar code reader 115, positioned to read bar codes printed upon bags or wrappers 52 through transparent support surface 117. The information read by reader 115 can be conveyed (e.g., via line 116) to the upstream insert placer 18 for proper insert selection.

Figures 10 and 11 show an alternate embodiment of the invention that is configured to automatically package a three-fold insert. Here, an automated bread packaging station 72 comprising a bread packaging machine 74, an infeed conveyor 76, an insert delivery tray 78, and an insert placer 80, configured to include a three-fold insert 82 with individual bread loaves 84 as they are wrapped. As described above, bread packaging machines are conventionally known in the art. The infeed conveyor 76 of packaging machine 74 conveys loaves of bread to the packaging machine, such as by a driven flight system to urge the individual loaves 84 along a smooth table. Insert placer 80 cycles between the solid position and the position shown in phantom. A servo 86 at the bottom of insert delivery tray 78 engages the bottommost insert 82 and urges it laterally to the insert pick-up position 88. In this embodiment, insert placer is driven laterally along rack 90 by pinion 92. Drive plate 94 has an arm 96 with stems 98, each ending in a vacuum cup 100. Selective operation of the vacuum cups allows the insert placer to pick up an insert and then drop it off as described above. As insert placer 80 moves laterally along rack 90, the drive plate rotates 180 degrees and arm 96 also rotates 180 degrees so that insert 82 is placed in drop-off position 102, immediately ahead of advancing loaf 84.

As shown in Figure 12, operation of this embodiment of the invention yields a loaf of bread 84, wrapped in a suitable package 103, with insert 82 folded around the loaf. Specifically, the first portion 104 of insert 82 is along one side of loaf 84, second portion 106 of the insert lies under the loaf, and third portion 108 of the insert is along the other side of the loaf. During packaging, the deposited three-fold insert 82 is driven forward along infeed conveyor 76 by advancing loaf 84. The bread packaging machine is substantially similar to the type described above. As the insert is pushed into the scoop, the first fold 104 is pushed up into a substantially vertical orientation. The loaf then falls onto second portion 106 and the third portion 108 is folded up allowing the clamshell to pull the wrapper over the loaf and suitably positioned insert. In some embodiments, it may be desirable to provide the scoop with a flange to help urge the third portion 108 of insert 82 into its vertical orientation.

One of skill in the art will recognize that this embodiment of the invention could easily be configured for a two-fold insert as well, so that one portion of the insert is along one side of the loaf and a second portion is underneath the loaf.

In the above embodiments, the proper alignment of the bread and insert relies upon certain frictional forces which exist as the bread and insert travel along the conveyor as they approach the bagger. Figure 13 shows an alternative embodiment of the invention, wherein the inserts are deposited onto the bread scoop, which subsequently receives the loaf of bread, rather than having the insert deposited onto the infeed conveyor ahead of the bread.

More specifically, in this embodiment, the insert delivery system comprises an insert card conveyor 216, and an insert placer 218, which are similar, respectively, to the insert delivery tray 16 and insert placer 18 described previously. In a preferred embodiment, as each insert 220 advances along the insert card conveyor 216, vacuum cups 230 of the insert placer 218 engage and secure the insert 220 and place the insert onto a feeder mechanism 231.

In this embodiment, as in the embodiments described previously, the invention includes an infeed conveyor 214, which is similar in structure and operation to infeed conveyor 14, a packaging machine 212, which is similar to packaging machine 12, and a scoop assembly (not shown), including lower bread scoop 260. As shown in Figure 13, the feeder mechanism 231 is adapted so as to be disposed adjacent, and above, a distal portion 215 of the infeed conveyor 214, as well as adjacent the lower bread scoop 260, when the latter is in the advanced, or extended, position. More specifically, the feeder mechanism 231, which is a timed advancement

mechanism, is positioned such that, as the lower bread scoop 260 moves towards the advanced position, such as is shown in phantom in Figure 13, the feeder mechanism 231 receives an insert 220 from the insert placer 218 and, at the appropriate time, feeds, or deposits, the insert 220 onto the lower bread scoop 260.

5 Referring to a PLC by way of example, in a preferred embodiment, the timed deposition of the insert 220 via the feeder mechanism 231, as well as the loading of the loaf 222 unto the scoop 260, are accomplished by a series of sensors located throughout the system which provide logistic information as input data into a PLC, which, in turn, sends output signals activating the various components of the system. More specifically, in a preferred embodiment, the sensors are  
10 positioned so as to provide at least three separate pieces of data as input into the PLC.

First, the bread loaf conveyor and the scoop assembly run on a single chain cycle. As such, an encoder, interacting with the PLC, ensures that the respective speeds of the bread conveyor, on the one hand, and the scoop, on the other, are synchronized. Second, as has been mentioned before with reference to Figure 2B, an optical (or similar) sensor is placed at a point  
15 that is preferably about 3/4 of the way along the infeed conveyor. When a loaf of bread that is on the conveyor and on its way to be loaded unto the scoop passes this point, it covers the sensor, thus signaling to the PLC that the loaf is about to reach the vicinity of the scoop assembly. The PLC then sends a signal to the scoop assembly for the latter to begin advancing towards its extended position. The PLC also uses this information to activate the insert placer and feeder  
20 mechanism. Finally, the scoop assembly itself is equipped with one or more position sensors, which help fine-tune the position of the scoop so that it will receive the insert and the loaf at an appropriate time and at the proper position.

The feeder mechanism 231 typically comprises two sets of rollers. A first set of rollers, placed towards the back of the mechanism, receive the insert 220 from the insert placer 218.  
25 When an appropriate signal is received from the PLC, a servo motor is activated to rotate these rollers, thus advancing the insert to the front portion of the infeed mechanism 231. Then, based on information received from the sensor(s) on the scoop assembly, the PLC sends a second signal to a second servo motor, which, in turn, causes the second set of rollers to advance the insert and shoot it out onto the scoop 260.

30 Based on the above description, the timing of insert deposition by the feeder mechanism 231 on the one hand, and the timing of bread advancement by the feeder conveyor 214, on the

other, are synchronized such that, for every loaf of bread 222 that moves along the conveyor, the feeder mechanism 231 loads the lower bread scoop 260 with an insert 220 prior to the arrival of the loaf. Thus, every time the lower bread scoop is advanced, it receives first an insert from the feeder mechanism 231, and then a loaf of bread 222, wherein the loaf rests on top of the insert.

5 More specifically, as a loaf of bread 222 is advanced on the infeed conveyor 214, a wrapper 252 is opened as described previously (with respect to wrappers 52), and the scoop assembly, including the lower bread scoop 260, move into position to receive an insert 220 and a loaf 222. The scoop assembly then continues to advance until its forward portion is inside the wrapper 252. Once inside, the scoop assembly then reverses direction, thus pulling the wrapper  
10 252 over the loaf 222, which then exits the scoop assembly. As the scoop assembly begins to move rearwardly, the insert 220 remains positioned under the loaf of bread 222 as the lower bread scoop 260 slides from underneath on its way back to the fully-retracted position (as shown, for example, in Figures 6-9, and the solid lines in Figure 13).

Once the wrapper 252 has been placed over the loaf 252 and insert 220, the bag is then  
15 tied in a tying machine (not shown; see, e.g., tying machine 70 in Figures 6-9). A label, sticker, or other similar medium is also affixed to the bag, wherein the medium contains information relating to the contents of the insert.

It is noted that the embodiment just described can also be used in conjunction with the various features that have been described previously with regard to the other embodiments. For  
20 example, the present embodiment of the invention can be configured to include multiple insert card conveyors (or one or more carousel and magazine assemblies) to carry a plurality of inserts, as well as a sensor, such as a UPC bar code reader, to help in selecting the proper insert for each wrapper.

The lower bread scoop 260 is similar to the lower member 60 of the scoop 56 depicted,  
25 e.g., in Figure 6. As shown in Figure 15, in order to keep the insert 220 stationary on the lower bread scoop 260, a horizontal surface 261, 361 of the scoop 260, 360 of the instant invention contains two sets of air apertures A and B. In a preferred embodiment, each set of apertures is aligned in a straight line, and the two lines are arranged parallel to each other. However, the apertures in each set, as well as the sets themselves, can be arranged in any configuration in order  
30 to accommodate the physical and functional requirements for practicing the invention.

An air-jet and vacuum chamber (not shown) is located adjacent the horizontal surface 261, 361 of the lower bread scoop 260, 360. The two sets of air apertures A, B are in turn connected to the air-jet and vacuum chamber via respective air lines (not shown) by conventional means.

Once the insert 220 has been fed, or advanced, onto the lower bread scoop 260 (i.e., once the lower bread scoop 260 has been loaded), suction is applied through the vacuum chamber and the air apertures A and/or A and B in order to securely retain the insert in place before the lower bread scoop 260, 360 receives a loaf of bread 222. The insert 220 and the loaf 222 are then advanced towards the wrapper 252 as described above.

As the scoop assembly begins to move rearwardly, i.e., away from the wrappers 252, the suction effected by the vacuum through air apertures A is terminated. At the same time, the air line connecting the air-jet chamber to air apertures B and/or A and B is activated (e.g., via an on/off toggle switch) to provide blow-off air through the horizontal surface 261, 361 of the lower bread scoop 260, 360. This helps separate the insert 220 from the horizontal surface 261, 361, so that it can remain positioned under the loaf of bread 222 as the lower bread scoop 260, 360 slides from underneath on its way back to the fully-retracted position (as shown, for example, in Figures 6-9, and 13).

As has been discussed previously, the timing and placement of the insert and the loaf are critical to the proper operation of the invented system. For example, for all of the embodiments discussed herein in which a feeder mechanism is used, the feeder mechanism may be placed either perpendicularly, or in a different orientation, with respect to the scoop assembly. The latter case is discussed in a subsequent section. However, in the former case, where the feeder mechanism and the scoop assembly are placed perpendicularly to each other (i.e., where the longitudinal axis of the feeder mechanism, defining the direction of movement of the insert on the feeder mechanism, is perpendicular to the longitudinal axis of the scoop, defining the direction of movement of the scoop), the feeder mechanism should preferably lie within a given range of angles as measured from the scoop and/or from the horizontal.

Depending on various factors including ease of access, machine location and the vantage point of an operator of the system of the instant invention, it may be advantageous to position the insert delivery system in a location away from a distal portion of the infeed conveyor. Thus, Figures 14 and 15 show an alternate embodiment of the invention, wherein the inserts are deposited onto the bread scoop in a retracted position, which subsequently receives the loaf of

bread, rather than having the insert deposited onto the infeed conveyor ahead of the bread, or onto the scoop when the latter has already advanced.

More specifically, in this embodiment, the insert delivery system comprises an insert card conveyor 316, and an insert placer 318, which are similar, respectively, to the insert car conveyor 216 and insert placer 218 described previously. In a preferred embodiment, as each insert 320 advances along the insert card conveyor 316, vacuum cups 330 of the insert placer 318 engage and secure the insert 320 and place the insert onto a feeder mechanism 331.

As shown in Figure 14, the feeder mechanism 331 is adapted so as to be disposed adjacent a lower bread scoop 360 of the scoop assembly described (and shown, in Figure 6-9, for example) previously. More specifically, the perpendicularly-positioned feeder mechanism, which is a timed advancement mechanism, is positioned such that, when the lower bread scoop 360 is in the retracted position (as shown in Figure 14), the feeder mechanism 331 receives an insert 320 from the insert placer 318 and, at the appropriate time, feeds, or advances, the insert 320 into the lower bread scoop 360. In a preferred embodiment, the timed deposition of the insert 320 via the feeder mechanism 331 is accomplished in substantially the same manner as that described for the embodiment depicted in Figure 13.

The lower bread scoop 360 is similar to the lower member 60 of the scoop 56 depicted, e.g., in Figure 6. Given that, in this embodiment, the insert 320 is loaded onto the lower bread scoop 360 when the latter is in the retracted position, it must be ensured that the insert 320 remains stationary on the scoop 360 as the scoop extends to receive the loaf of bread 322 on top of the insert 320. Therefore, as shown in Figure 15, the lower bread scoop 260, 360 of the instant invention has a horizontal surface 261, 361 which contains two sets of air apertures A and B. In a preferred embodiment, each set of apertures is aligned in a straight line, and the two lines are arranged parallel to each other. However, the apertures in each set, as well as the sets themselves, can be arranged in any configuration in order to accommodate the physical and functional requirements for practicing the invention.

An air-jet and vacuum chamber (not shown) is located adjacent the horizontal surface 261, 361 of the lower bread scoop 260, 360. The two sets of air apertures A, B are in turn connected to the air-jet and vacuum chamber via respective air lines (not shown) by conventional means.

Once the insert 320 has been fed, or advanced, onto the lower bread scoop 260, 360 (i.e.,

once the lower bread scoop 260, 360 has been loaded), suction is applied through the vacuum chamber and first set of air apertures A in order to securely retain the insert in place as the lower bread scoop 260, 360 moves forward (as shown, e.g., in Figure 7), to receive a loaf of bread 322.

In this embodiment, as in the embodiments described previously, the invention includes an infeed conveyor 314, which is similar in structure and operation to infeed conveyor 14, a packaging machine 312, which is similar to packaging machine 12, and a scoop assembly (not shown), including lower bread scoop 360. As a loaf of bread 322 is advanced on the infeed conveyor 314, a wrapper 352 is opened as described previously (with respect to wrappers 52), and the scoop assembly, including the lower bread scoop 360 that is carrying the insert 320, moves forward toward the wrappers 352 in order to receive the loaf 322. The scoop assembly then continues to advance until its forward portion is inside the wrapper 352. Once inside, the scoop assembly then reverses direction, thus pulling the wrapper 252 over the loaf 322, which then exits the scoop assembly.

As the scoop assembly begins to move rearwardly, i.e., away from the wrappers 352, the suction effected by the vacuum through air apertures A is terminated. At the same time, the air line connecting the air-jet chamber to the second set of air apertures B is activated (e.g., via an on/off toggle switch) to provide blow-off air through the horizontal surface 261, 361 of the lower bread scoop 260, 360. This helps separate the insert 320 from the horizontal surface 261, 361, so that it can remain positioned under the loaf of bread 322 as the lower bread scoop 260, 360 slides from underneath on its way back to the fully-retracted position (as shown, for example, in Figures 6-9, and 14).

Once the wrapper 352 has been placed over the loaf 352 and insert 320, the bag is then tied in the tying machine 370. It is noted that the embodiment just described can also be used in conjunction with the various features that have been described previously with regard to the other embodiments. For example, the present embodiment of the invention can be configured to include multiple insert card conveyors (or one or more carousel and magazine assemblies) to carry a plurality of inserts, as well as a sensor, such as a UPC bar code reader, to help in selecting the proper insert for each wrapper.

As has been discussed previously, timing and placement are critical to the proper operation of the present invention. Thus, with respect to the embodiments shown in Figures 13-15, for example, it is important that the feeder mechanism be positioned, and its insert-

advancement mechanism timed, so as to feed the insert onto the scoop in such a way that the insert lands on top of, and covers, all of the vacuum apertures of the scoop. In fact, if the feeder mechanism is not positioned properly, the insert might bounce away from the scoop as it leaves the feeder mechanism. Moreover, mispositioning and/or mistiming of the feeder mechanism may  
5 cause the insert to cover less than all of the apertures, which, in turn, would prevent the vacuum system from functioning properly to retain the insert in place. Similarly, the advancement of the scoop should preferably be timed such that the insert is released into the wrapper so as to lie underneath the loaf, between the middle portion and the distal end (i.e., the end that is not twist wrapped) of the loaf.

10 In another alternative embodiment, shown in Figure 16, a bread scoop 460 comprises a horizontal surface 461, as well as a distal end 462. In contrast with the previous embodiment, where an insert 420 would be placed on top of the horizontal surface 461, in the present embodiment, the scoop 460 is equipped with a lower compartment 465, which is disposed  
underneath the lower surface of the horizontal surface 461 and which receives the insert 420 when  
15 the bread scoop 460 is in the retracted position.

Thus, as was described previously with respect to the embodiment depicted in Figures 14 and 15, a feeder mechanism (not shown) or similar device may be used to deposit the insert 420 into the lower compartment 465 at the appropriate time, wherein such delivery of the insert into the compartment is timed so as to be coordinated with the movement of loaves of bread on an  
20 infeed conveyor (see, e.g., Figure 14). It is noted that, in this embodiment, the perpendicularly-positioned feeder mechanism 431 is preferably located vertically lower (i.e., closer to the ground) than in previous embodiments. In addition, for the purposes of this embodiment, the scoop is preferably rotated about 15° around its longitudinal axis, such that the edge closer to the feeder mechanism is tilted upwards (see Figure 16B). Moreover, the front portion of the feeder  
25 mechanism 431 should preferably be tilted down at an angle of between about -15° and about 15° with respect to the edge of the scoop that is tilted upwards (i.e., about 15° above to about 15° below the edge of the scoop that is tilted upwards). Thus, as an example, Figure 16B shows a preferred configuration, wherein the scoop has been tilted about 15°, and the feeder mechanism is tilted down about 10°.

30 Once the scoop 460 has been loaded with the insert 420, the scoop 460 advances towards a forward position in order to receive a loaf of bread, and then proceeds to enter a wrapper with its

distal end 462, all in the same manner as that described with respect to the embodiment depicted in Figures 14 and 15.

As shown in Figure 16A, the lower compartment 465 has a distal end 466 which may or may not extend as far forward as the distal end 462 of the bread scoop 460. Once the distal end 5 462 of the scoop and the distal end 466 of the lower compartment have fully advanced into the wrapper, a plunger 468, that is slidably coupled to the lower compartment, is moved forward toward the distal end 466 of the lower compartment 465 in order to expel the insert 420 into the wrapper. The scoop assembly then reverses direction, thus depositing the loaf of bread on top of the insert 420 while pulling the wrapper over the loaf. As the scoop assembly begins to move 10 rearwardly, the insert 420 remains positioned under the loaf of bread as the lower compartment and bread scoop slide from underneath on their way back to the fully-retracted position. As before, once the wrapper has been placed over the loaf and insert 420, the wrapper is then tied in a tying machine (not shown).

The plunger 468 is mechanically connected to the bagger, so that synchronization exists 15 between the two components via the PLC. It has been found that, for proper operation of an embodiment of the invention, the release of the insert 420 into the wrapper should be effected within a time window that begins when, as the scoop 460 advances towards the wrapper, the distal end 462 of the scoop 460 is about 3 inches from its fully-extended position, and ends when, on its way back to the retracted position, the distal end 462 of the scoop 460 is again about 3 inches 20 from its fully-extended position. Deposition of the insert 420 into the wrapper within the specified time period helps ensure that the insert 420 will be properly retained in place as the scoop assembly retracts, as well as stay out of the way of the twist wrapping operation of the bagging system.

It is noted that the embodiment just described can also be used in conjunction with the 25 various features that have been described previously with regard to the other embodiments. For example, the present embodiment of the invention can be configured to include multiple insert card conveyors (or carousel and magazine assemblies) to carry a plurality of inserts, as well as a sensor, such as a UPC bar code reader, to help in selecting the proper insert for each wrapper.

It is also noted that, although in the embodiment that has been shown in Figure 16A, the 30 lower compartment 466 is shorter in length than the bread scoop 460, it is not necessary that this be the case. Thus, in a preferred embodiment, the distal ends 462 and 466 are aligned. Moreover,

although Figure 16A shows the use of a plunger 468, other means for expelling the insert 420 from the lower compartment 465 may also be used. For example, the insert 420 may be expelled by compressed air, or through the use of a pneumatic cylinder or other similar means for urging the insert towards the distal end 466 of the lower compartment 465. Additionally, a vacuum and  
5 blow-off air system, similar to those used in the embodiments discussed previously, and shown in Figure 15, may be used in conjunction with the present embodiment.

Figures 17A – 17C show an alternative embodiment, in which the function of the plunger 468 is replaced with a slit and bar arrangement. More specifically, as shown in the figures, the horizontal surface 461 has a slit 463 than runs substantially through the longitudinal axis of the  
10 horizontal surface. It is noted that, in Figures 17A – 17C, the slit 463 is shown for illustrative purposes to run only through a portion of the length of the horizontal surface 461. However, the actual length of the slit 463 vis-à-vis the horizontal surface 461 will be determined based on functional, operational, spatial, and other such considerations.

The scoop assembly is also equipped with a stop bar 485 which is positioned substantially  
15 perpendicularly with respect to the horizontal surface 461. The stop bar 485 may be coupled to an air cylinder, which lowers and raises the stop bar in a vertical direction. In addition, the stop bar 485 may operate independently, or, in a preferred embodiment, it may be coupled to the pushing assembly 64 (see, e.g., Figures 6-9).

In either case, the stop bar 485 is equipped with a pressure sensing device which allows  
20 operation of the stop bar depending on whether or not an insert 420 is in contact with the stop bar. In this way, the stop bar also helps ensure continued and uninterrupted operation of the system. That is, the pressure sensing device may be calibrated for a threshold pressure such that, when an envelope which is stuck in the lower compartment comes into contact with the stop bar so as to create a pressure that is greater than the threshold pressure, the stop bar automatically moves up,  
25 so that it does not impede the continued operation of the bagger.

Figure 17A shows the lower scoop 460 in a retracted position. In this position, the stop bar 485 is raised out of the slit 463, so that an insert 420 may be placed in the lower compartment 465 as discussed previously. Once the lower compartment has been loaded, the lower scoop 460 begins to move forward, in the direction of Arrow A (as shown in Figure 17B). At this time, the  
30 stop bar 485 is lowered. In a preferred embodiment, the lower compartment 465 has a groove (not shown) that runs substantially through the longitudinal axis of the lower compartment 465.

Thus, when the stop bar 485 is lowered, its bottom end enters the groove of the lower compartment, such that the bottom end of the stop bar is positioned vertically lower than the surface of the lower compartment, where the insert 420 is resting. In this way, the possibility that the insert 420 will be caught between the bottom end of the stop bar and the surface of the lower compartment is substantially eliminated. In addition, since the scoop is moving in the direction of Arrow A, the insert 420 will slide in the opposite direction, thus bringing an edge of the insert 420 into contact with the stop bar 485.

Once the scoop has been fully extended and a bread loaf loaded (as has been discussed previously), the scoop and lower compartment begin to retract. Thus, with reference to Figure 17C, the lower scoop 460 and the lower compartment 465 now move in the direction of Arrow B. As this movement is initiated, the stop bar 485 remains stationary. Since the stop bar 485 is in contact with the insert 420, continued movement of the lower compartment in the direction of Arrow B will cause the insert 420 to move towards the distal end 466 of the lower compartment 465. Thus, just as the pushing assembly 64 pushes the bread loaf off the lower scoop 461 while the latter is retracting, the stop bar 485 pushes the insert 420 off the lower compartment 465 as the latter is retracting, which allows the loaf to end up on top of the insert. As before, while the scoop assembly retracts, it also pulls the wrapper over the loaf and insert.

It is noted that, in an embodiment of the invention, multiple stop bars may be used. Thus, for example, in an embodiment where two stop bars are used, each stop bar moves up and down through a corresponding slit in the lower scoop, and into a corresponding groove in the lower compartment. Moreover, each of the stop bars may be equipped with its own pressure sensing device. In this arrangement, the stop bars move in synchronicity with each other such that, when one of the stop bars moves up or down, so does the other. In addition, the two or more stop bars may operate as a single structure. Thus, for example, in the embodiment just described, the two stop bars may be connected to each other by a horizontal member so as to result in a single structure having the shape of an inverted U.

Figure 17D shows an alternative embodiment in which the stop bar 485 has a wedge, or flange, 487. In operation, when the insert exits the lower compartment as was described with reference to Figs. 17A – C, the trailing edge of the insert may lie close enough to one end of the loaf of bread such that, once the insert and loaf have been bagged, the corners of the trailing edge of the insert may poke holes into the bag. To address this potential problem, the wedge 487 helps

ensure that the insert is pushed an extra distance away from the distal end 466 of the lower compartment and, thus, away from the end of the bread loaf. It is noted that the same effect may be achieved by replacing the wedge with a ball-shaped structure at the bottom end of the stop bar 485, or by including a flange to create a L-shaped, I-shaped, or similar member. Alternatively, an  
5 air cylinder may be used to push the stop bar 485 forward (i.e., towards the bagger) once the scoop and the lower compartment have been retracted. This would push the insert further forward and away from the end of the loaf.

The embodiments of the invention described herein may also include an ejection mechanism whose operation is synchronized with the operation of the insert delivery system and  
10 the automated product packager. Referring to Figures 16 and 17, for example, it is possible that, from time to time, an insert will be misfed into the lower compartment or, even if correctly fed, the insert may crumple and become stuck in the lower compartment. Such an occurrence would, of course, disrupt proper operation of the invention. As such, the system may include an ejection mechanism that utilizes air pressure, a mechanical device (e.g., a plunger), an electro-mechanical  
15 device, or other similar means to ensure that inserts that have been misfed, are stuck, or otherwise obstruct the continuous operation of the system are removed.

Figure 18 is an illustrative schematic of an alternative arrangement of an embodiment of the invention. As before, the lower scoop 460 and the infeed conveyor 414 are situated  
20 substantially perpendicularly to each other. However, the infeed mechanism 431 (more generally referred to as an insert deposition mechanism) is no longer situated perpendicularly with respect to the scoop. Rather, it is positioned adjacent the scoop such that its longitudinal axis is parallel to that of the scoop.

Such an arrangement allows for several advantages. First, the insert is delivered in the direction of movement of the scoop assembly (Arrow C in Figure 18). This provides for  
25 simplified synchronization of the operation of the insert delivery system and the automated product packager.

Second, a plurality of inserts, as opposed to a single insert, can be delivered to the scoop assembly. Thus, for example, two separate insert deposition mechanisms can be placed adjacent  
30 the scoop (e.g., the position shown for insert deposition mechanism 431 in Figure 18) in such a way as to allow one mechanism to deliver an insert through side A of the scoop, and the other to deliver an insert through the horizontal surface 461 of the scoop. The two insert deposition

mechanisms would then operate substantially simultaneously in order for the inserts to be delivered substantially simultaneously which, in turn, would allow both inserts to be deposited in the same bag, one on each side of the loaf of bread.

Alternatively, a single, modified, insert deposition mechanism may be used to deliver  
5 more than one insert to the scoop at a time. Moreover, depending on whether one or a plurality of insert deposition mechanism are used, the system can be configured to operate in conjunction with one or more carousels, each having one or more magazines. Thus, in the illustrative example above, where two inserts are included in each bag, each insert can be taken from a different magazine on the same carousel, or from magazines on separate carousels, thus increasing the  
10 variety of inserts that can be used and decreasing the time required to include more than one insert in each bag.

With reference to Figure 18, in an alternative embodiment, the scoop assembly may be equipped with one or more rollers, each of which rotates in the direction of movement of the lower scoop. In an illustrative example, a roller may be placed adjacent side A, and a second one  
15 adjacent the horizontal surface 461. In operation, the insert disposition mechanism presents an insert to each one of said rollers, each of which, in turn, draws its respective insert in a direction towards the distal end of the scoop, thus depositing the insert on the appropriate side of the scoop. At this point, a stop bar of the kind discussed previously moves down and urges the insert forward as the scoop extends forward.

20 The inserts of the invention can comprise a wide variety of items and are not limited to thin, planar objects. Typically, the inserts will be printed material such as coupons, product information sheets, promotional material and the like. However, the insert may also comprise game pieces for contests, sweepstake materials, trading cards, or prizes. The insert may also comprise an envelope having one or more enclosures of the type listed above. Also, the inserts  
25 can be product samples such as tea bags, coffee, and dried soup powders contained in suitable pouches. Similarly, in the embodiments of the invention utilizing two- and three-fold inserts, the insert may comprise a perforated or otherwise prefolded card, or may comprise an envelope having a corresponding number of pockets. Oftentimes, the size of an insert can be dictated by the Uniform Coupon Council. Currently, the preferred sizes are approximately 3" x 6" and 2 3/4"  
30 x 6 1/2"; other sizes such as 2.5" x 8" are also within the scope of the invention.

Although several embodiments have been described herein, one skilled in the art that

pertains to the present invention will understand that there are equivalent alternative embodiments. In particular, the embodiments have been described with reference to the delivery of an insert to be automatically packaged with a loaf of bread. However, the invention may also be used with any other similarly-packaged product.

What is claimed is:

1. An insert delivery system for use with an automated packaging machine, wherein the packaging machine comprises an infeed to convey a product to be packaged and a scoop assembly, comprising:

5 (a) a first insert card conveyor configured to present a first insert to an insert placer; and

(b) a feeder mechanism that is disposed adjacent said insert card conveyor and insert placer and is configured to deliver the insert onto the scoop assembly;

10 wherein the insert placer comprises at least one arm that is adapted to move in a plurality of linear directions.

2. The insert delivery system of claim 1, wherein the at least one arm cycles between an insert pick-up position and an insert drop-off position.

15 3. The insert delivery system of claim 2, wherein the insert card conveyor is a carousel equipped with at least one magazine, and the at least one arm comprises an insert holder that is configured to be adjacent said magazine and secure the insert when the arm is in the insert pick-up position and configured to be adjacent the feeder mechanism and release the insert when the arm is in the insert drop-off position.

20

4. The insert delivery system of claim 3, wherein the insert holder comprises a vacuum system.

25 5. The insert delivery system of claim 4, wherein the at least one magazine is vertically oriented and is adapted to hold a plurality of inserts which are placed horizontally in the magazine and are stacked in a vertical arrangement.

6. The insert delivery system of claim 5, further comprising at least one sensor, wherein information from the sensor is used to activate a magazine insert advancement mechanism to move the stack of inserts up in the vertical direction.

5 7. The insert delivery system of claim 1, wherein the automated packaging machine comprises an automatic bread loaf packager.

8. The insert delivery system of claim 1, wherein the insert is at least one member selected from the group consisting of envelopes having at least one enclosure, and packets of food  
10 product samples.

9. The insert delivery system of claim 1, wherein the scoop assembly is equipped with at least one position sensor.

15 10. The insert delivery system of claim 9, further comprising a control mechanism and an encoder, said control mechanism controlling the operation of the insert delivery system and automated packaging machine, and said encoder being configured to communicate with the control mechanism to synchronize the respective speeds of said infeed conveyor and scoop  
20 assembly.

11. The insert delivery system of claim 10, further comprising an infeed sensor positioned along said infeed conveyor, said sensor being in electronic communication with said control mechanism and being configured to detect and communicate the presence of said product to the control mechanism.

25

12. The insert delivery system of claim 11, wherein the at least one position sensor of the scoop assembly is in electronic communication with the control mechanism.

13. The insert delivery system of claim 1, wherein said packaging machine includes  
5 wrappers, each wrapper bearing a UPC bar code.

14. The insert delivery system of claim 13, wherein the wrappers are stacked upon a transparent support through which a UPC bar code reader is positioned to read the UPC bar codes on the wrappers and to convey the UPC bar code data to said insert placer.

10

15. The insert delivery system of claim 14, further comprising a control mechanism, said control mechanism being in electronic communication with the UPC bar code reader and the insert placer.

16. An insert delivery system for use with an automated packaging machine,  
15 comprising:

(a) a first vertical magazine configured to present a first insert to an insert placer; and

(b) a feeder mechanism, disposed adjacent said magazine and insert placer, and  
configured to receive said first insert from said insert placer;

20 wherein the packaging machine comprises an infeed conveyor to convey a product to be packaged and a scoop assembly, the scoop assembly comprising:

(i) a lower bread scoop having a horizontal surface which is configured to receive said product to be packaged, said horizontal surface having a slit that runs substantially through the longitudinal axis thereof; and

25 (ii) a lower compartment that is disposed underneath said horizontal surface and is adapted to receive said insert,

the scoop assembly being adapted to cycle between a retracted position and a forward position, and the insert delivery system being configured so that the feeder mechanism delivers the insert onto the scoop assembly when the scoop assembly is in the retracted position.

5           17.     The insert delivery system of claim 16, wherein the lower compartment has a groove that runs substantially through the longitudinal axis thereof, further comprising a stop bar that is adapted to move vertically up and down through said slit so as to have its lower end inside said groove and be in contact with an edge of said insert when the insert is placed in the compartment and the stop bar is in its lower-most position.

10

18.     The insert delivery system of claim 17, wherein the stop bar is a pressure-sensitive device and is configured to be operated by an air cylinder.

15           19.     The insert delivery system of claim 17, further comprising a control mechanism, an encoder, an infeed sensor positioned along said infeed conveyor, and at least one position sensor connected to the scoop assembly, wherein:

the infeed conveyor and the scoop assembly are configured to run on a single chain cycle;

the control mechanism is configured to control the operation of the insert delivery system and automated packaging machine;

20           the encoder is configured to communicate with the control mechanism to synchronize the respective speeds of said infeed conveyor and scoop assembly;

the infeed sensor is configured to detect and communicate the presence of said product to the control mechanism; and

25           the at least one position sensor is in electronic communication with the control mechanism.

20. The insert delivery system of claim 19, wherein the feeder mechanism is disposed perpendicularly with respect to the scoop assembly, the scoop is rotated about 15° about its longitudinal axis, and the front portion of the feeder mechanism is tilted at an angle of between about -15° and about 15° with respect to the scoop.

5

21. The insert delivery system of claim 19, wherein the feeder mechanism is disposed parallel to the longitudinal axis of the scoop assembly.

22. The insert delivery system of claim 19, further comprising an ejection mechanism  
10 configured to clear the lower compartment of misfed or stuck inserts.

23. A method of including an insert with a product being automatically packaged, comprising the steps of:

(a) providing an automated packaging machine having an infeed conveyor and a scoop  
15 assembly, said scoop assembly including:

(i) a lower bread scoop having a horizontal surface which has a slit through the longitudinal axis thereof and is configured to receive said product to be packaged; and

(ii) a lower compartment that is disposed underneath said horizontal surface and is adapted to receive said insert;

20 (b) providing an insert delivery system having:

(i) a first vertical magazine configured to present a first  
insert to an insert placer; and

(ii) a feeder mechanism to receive said first insert from said insert placer,

25 wherein the insert delivery system is configured so that the feeder mechanism delivers the insert onto the scoop assembly;

- (c) advancing a product along the infeed conveyor;
- (d) operating a holder on the insert placer to secure the insert from the magazine;
- (e) moving the insert placer so that the holder is adjacent the feeder mechanism;
- (f) releasing the insert from the holder so that the insert is deposited on the feeder  
5 mechanism;
- (g) operating the feeder mechanism to deliver the insert onto said lower compartment  
when the scoop assembly is in a retracted position;
- (h) receiving the product on the scoop assembly;
- (i) lowering a stop bar through said slit so as to urge said insert out of a distal end of  
10 the lower compartment;
- (j) packaging the product and the insert.

24. The method of claim 23, further comprising:

providing a control mechanism to control the operation of the insert delivery system and  
the automated packaging machine;

15 providing an infeed sensor positioned along said infeed conveyor;

as the product advances along the infeed conveyor, detecting the location of the product  
via the infeed sensor and electronically conveying said location to the control mechanism; and

20 at the appropriate points in time, transmitting, based on said location of the product,  
activation signals from the control mechanism to each of the insert placer, the feeder mechanism,  
and the scoop assembly such that steps (f), (g), and (h) are carried out sequentially.

25. The method of claim 24, further comprising:

providing at least one position sensor connected to the scoop assembly; and

activating the at least one position sensor to provide the control mechanism with the

position of the scoop assembly so as to allow the control mechanism to fine-tune said position of the scoop assembly prior to performing step (h).

26. The method of claim 23, wherein the delivery system further comprises a second  
5 magazine having a second insert and wherein the first and second magazines are configured to attain first and second positions such that in the first position, the first magazine presents the insert to the insert placer and in the second position the second magazine presents the second insert to the insert placer, further comprising the step of moving the first and second magazines from the first position to the second position and wherein the step of operating the holder  
10 comprises securing the second insert.

27. The method of claim 26, further comprising the step of sensing the product being packaged and wherein the step of moving the first and second magazines is controlled in response to information obtained from the sensing step.

15

28. The method of claim 26, further comprising the step of providing at least two feeder mechanisms, each said feeder mechanism providing a separate insert on a different side of the scoop assembly, thereby resulting in a package which has an insert on each of at least two sides of the packaged product.

20

29. A method of including an insert with a loaf of bread being automatically packaged, comprising the steps of:

(a) providing an automated packaging machine having an infeed conveyor and a bread receiving scoop assembly having a lower bread scoop which includes a horizontal surface, said  
25 horizontal surface including a slit through the longitudinal axis thereof;

(b) providing an insert delivery system having a carousel equipped with at least one magazine configured to present a first insert to an insert placer, wherein the insert delivery system

is configured so that the insert placer delivers the insert onto a feeder mechanism;

(c) providing a lower compartment that is disposed underneath said horizontal surface and is adapted to receive said insert;

(d) advancing the bread loaf along the infeed conveyor;

5 (e) operating a holder on the insert placer to secure the insert from the magazine;

(f) moving the insert placer so that the holder is adjacent the feeder mechanism;

(g) releasing the insert from the holder so that the insert is deposited on the feeder mechanism;

(h) delivering the insert from the feeder mechanism to the lower compartment;

10 (i) advancing the scoop assembly into a forward position;

(j) depositing the bread loaf into the lower bread scoop with the insert in the lower compartment;

(k) operating a stop bar that is slidably coupled to the lower scoop so as to urge said insert out of a distal end of the lower compartment;

15 (l) depositing the bread loaf on top of the insert; and

(m) pulling a wrapper over the bread loaf and the insert.

30. The method of claim 29, wherein the holder has at least one arm, and steps (e) – (g) are performed by the sequential steps of:

20 (a) lowering said arm in a vertical direction to secure the insert;

(b) raising the arm and moving said arm in a horizontal direction so as to be placed above the feeder mechanism; and

(c) lowering the arm in a vertical direction to release the insert onto the feeder mechanism.

31. The method of claim 30, wherein said compartment has a distal end and, in step (k), the stop bar is vertically lowered through said slit in the horizontal surface of the lower scoop so as to be substantially in contact with an edge of said insert and with the bottom of the compartment such that, as the lower scoop and compartment start to retract, the stop bar urges the  
5 insert out of the distal end of said compartment.

32. The method of claim 31, further comprising activating an ejection mechanism to clear the lower compartment of misfed or stuck inserts.

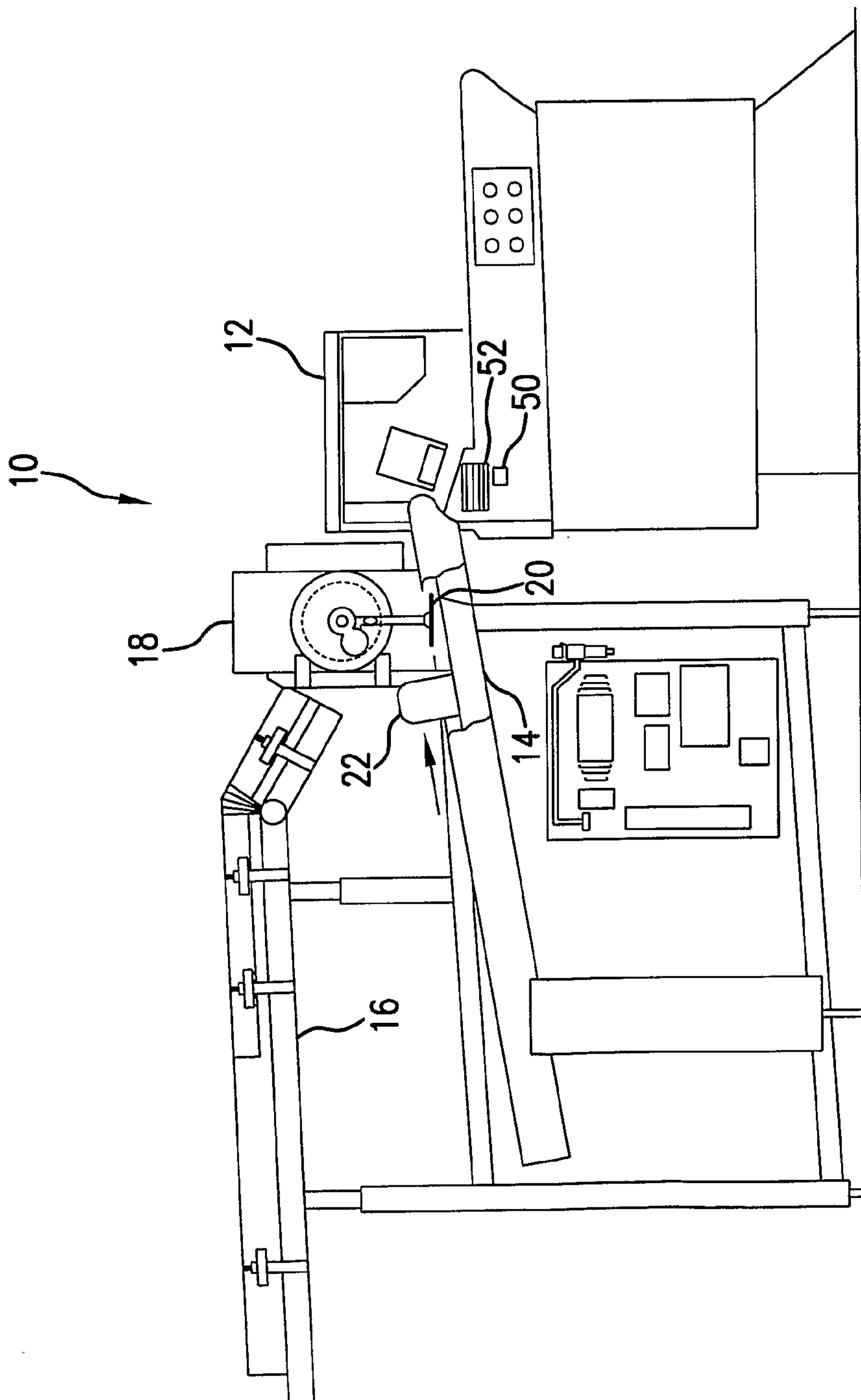

FIG.1

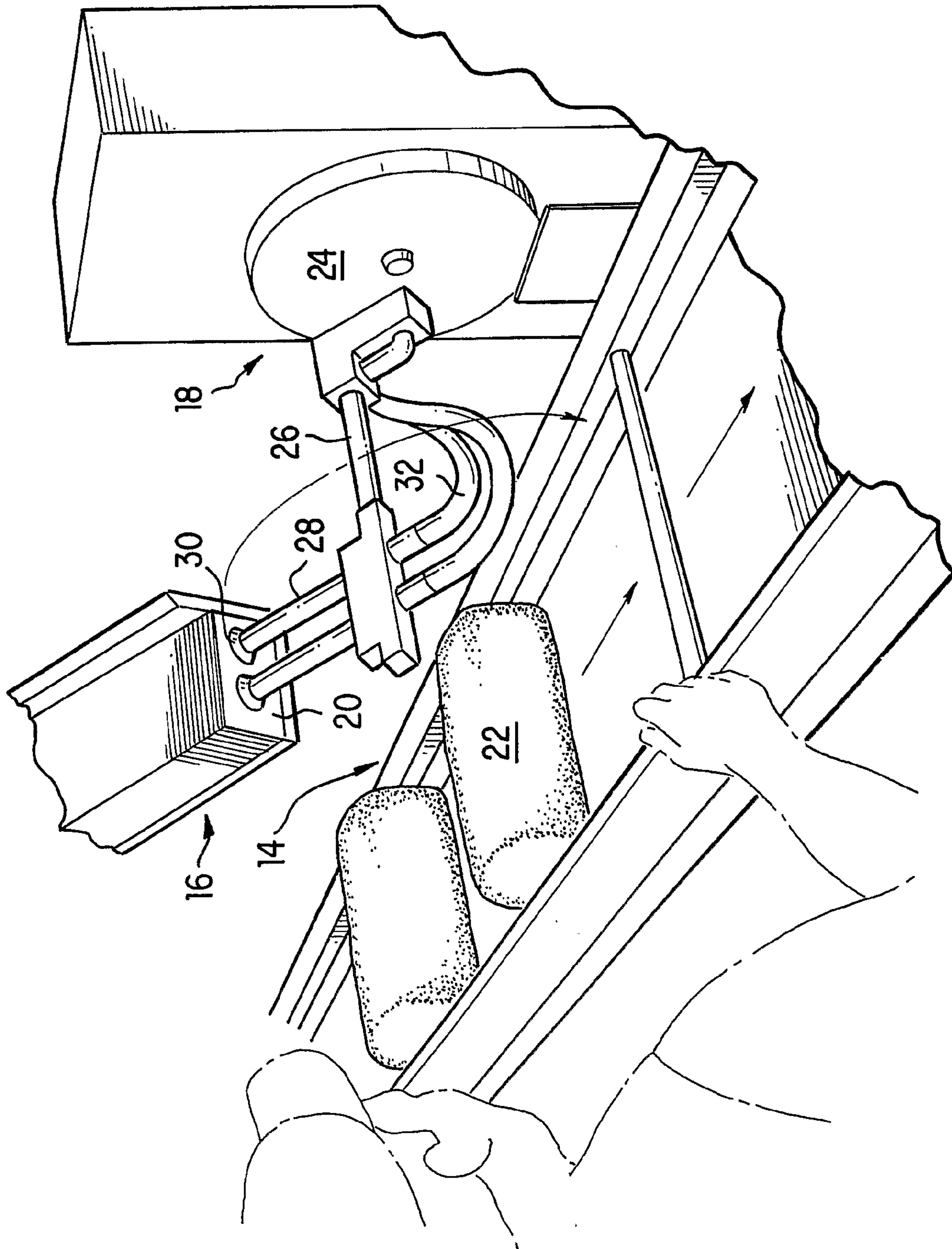

FIG. 2A

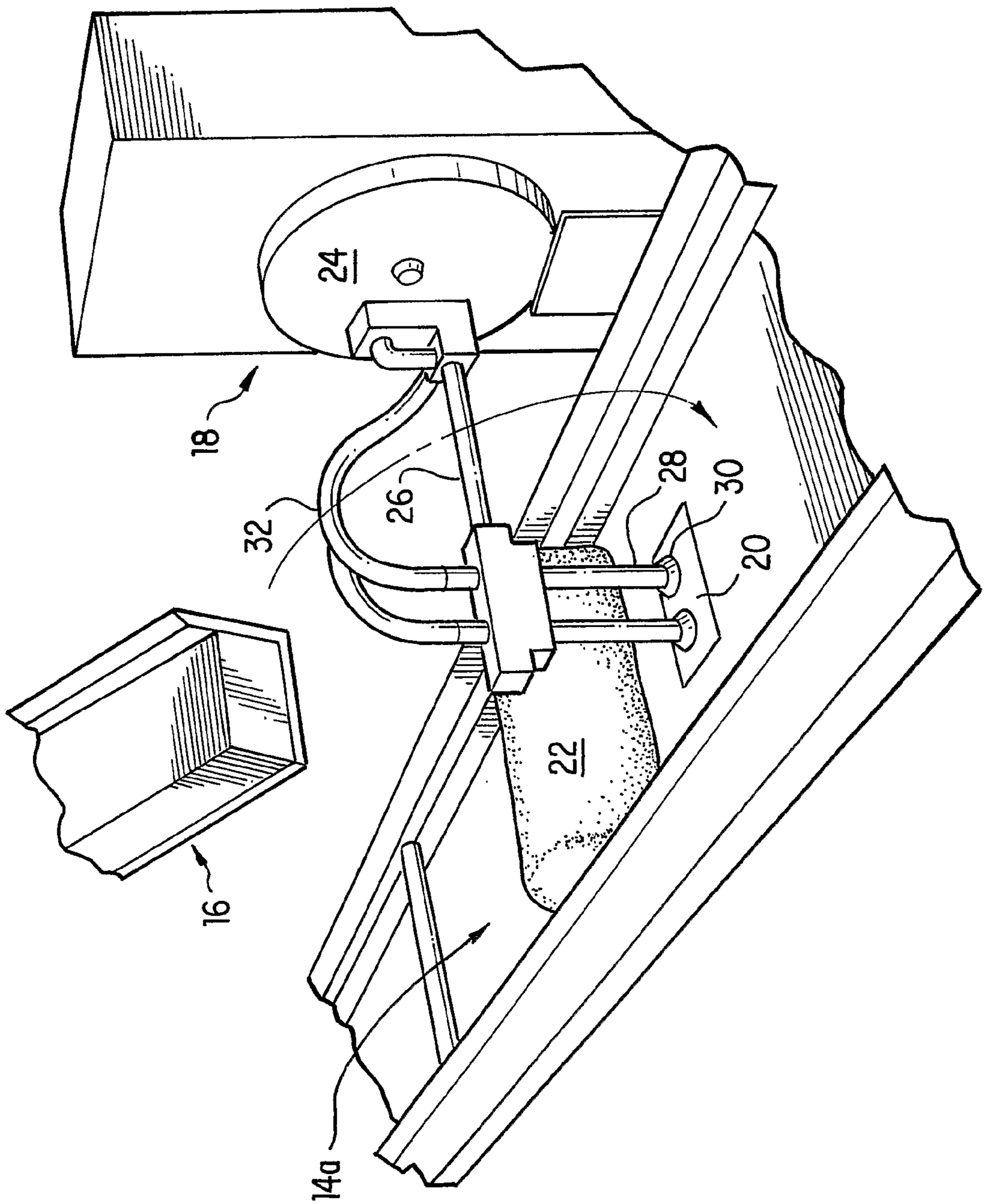

FIG. 2B

4/21

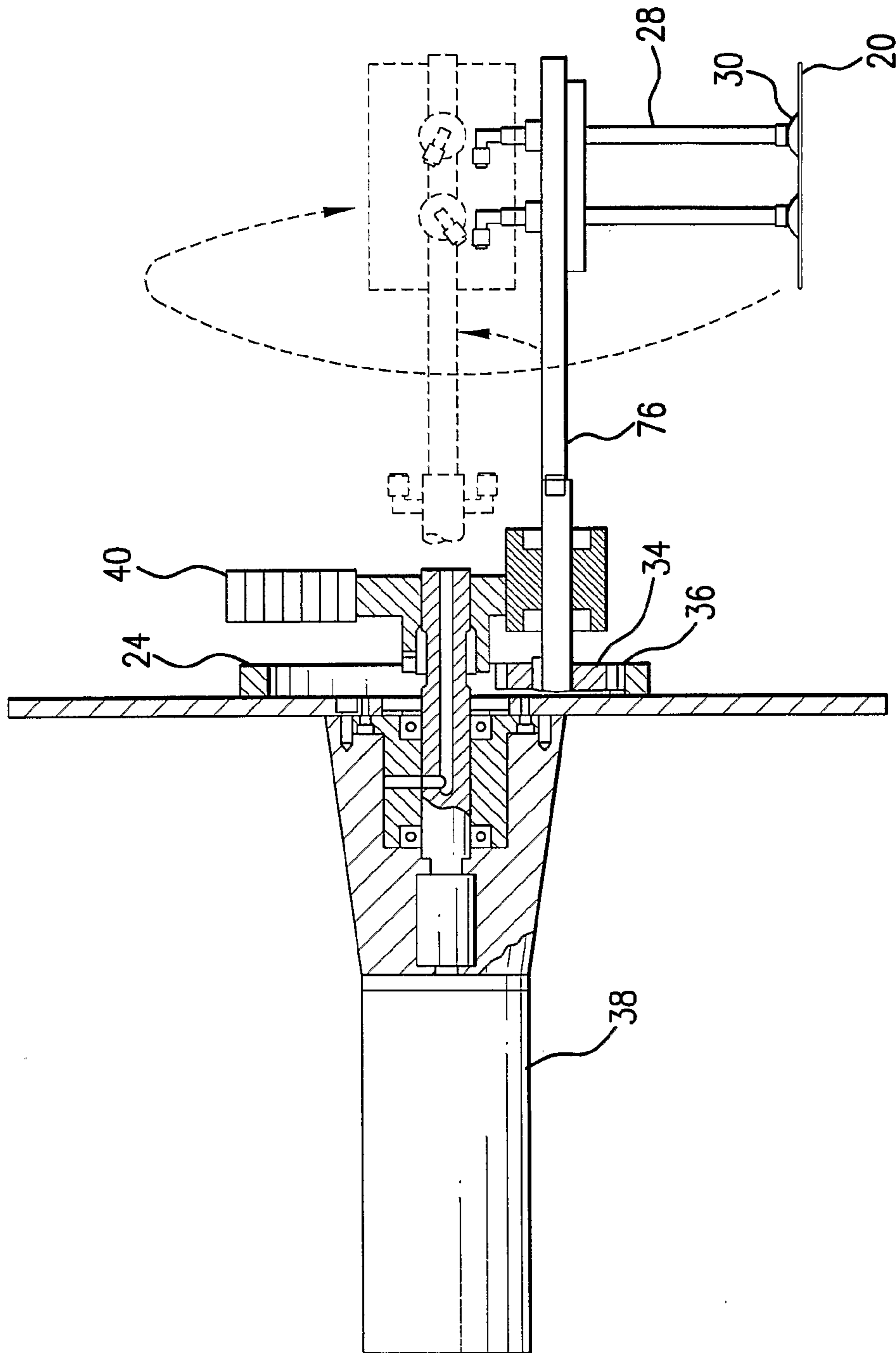

FIG. 3

5/21

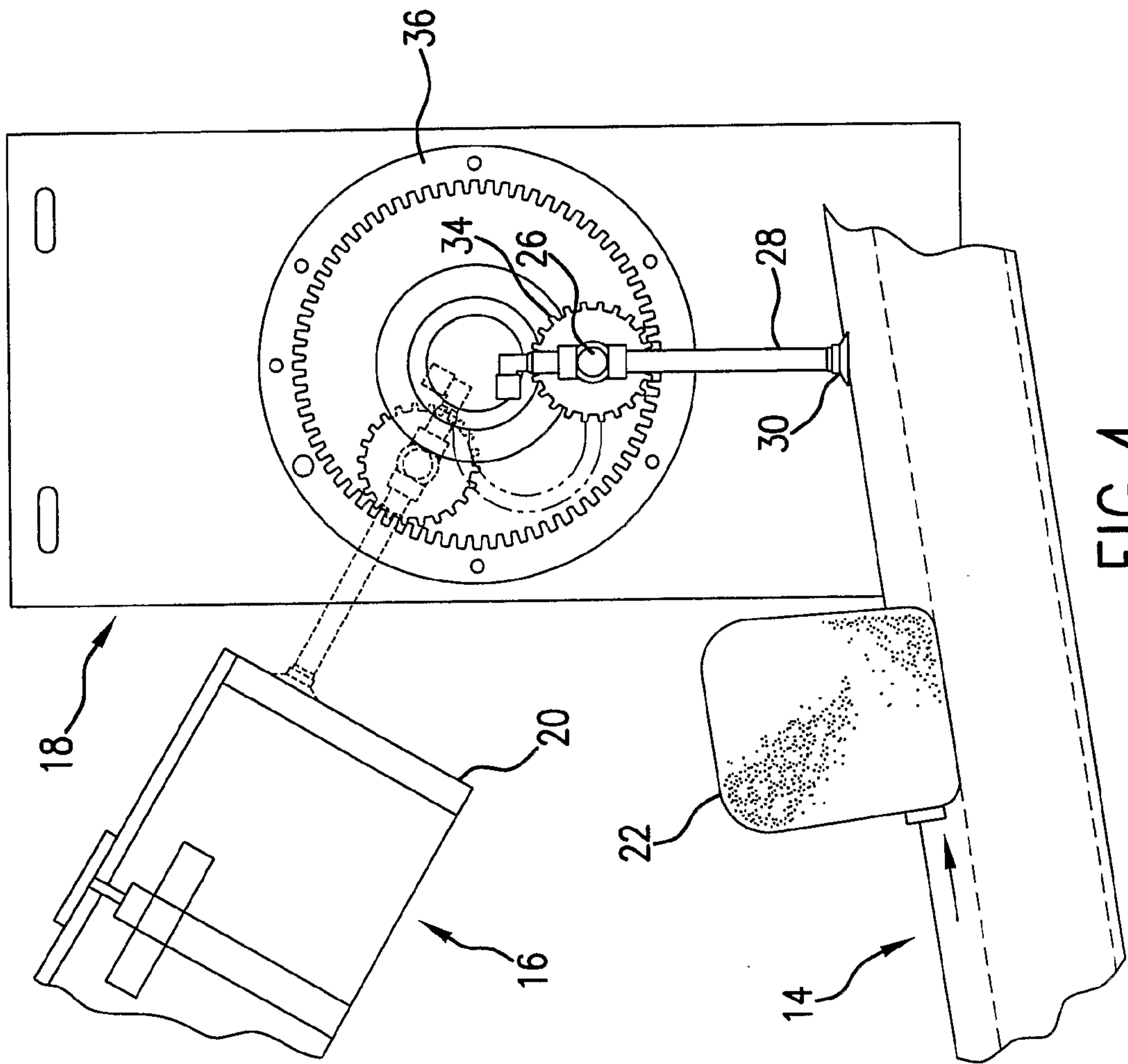

FIG.4

6/21

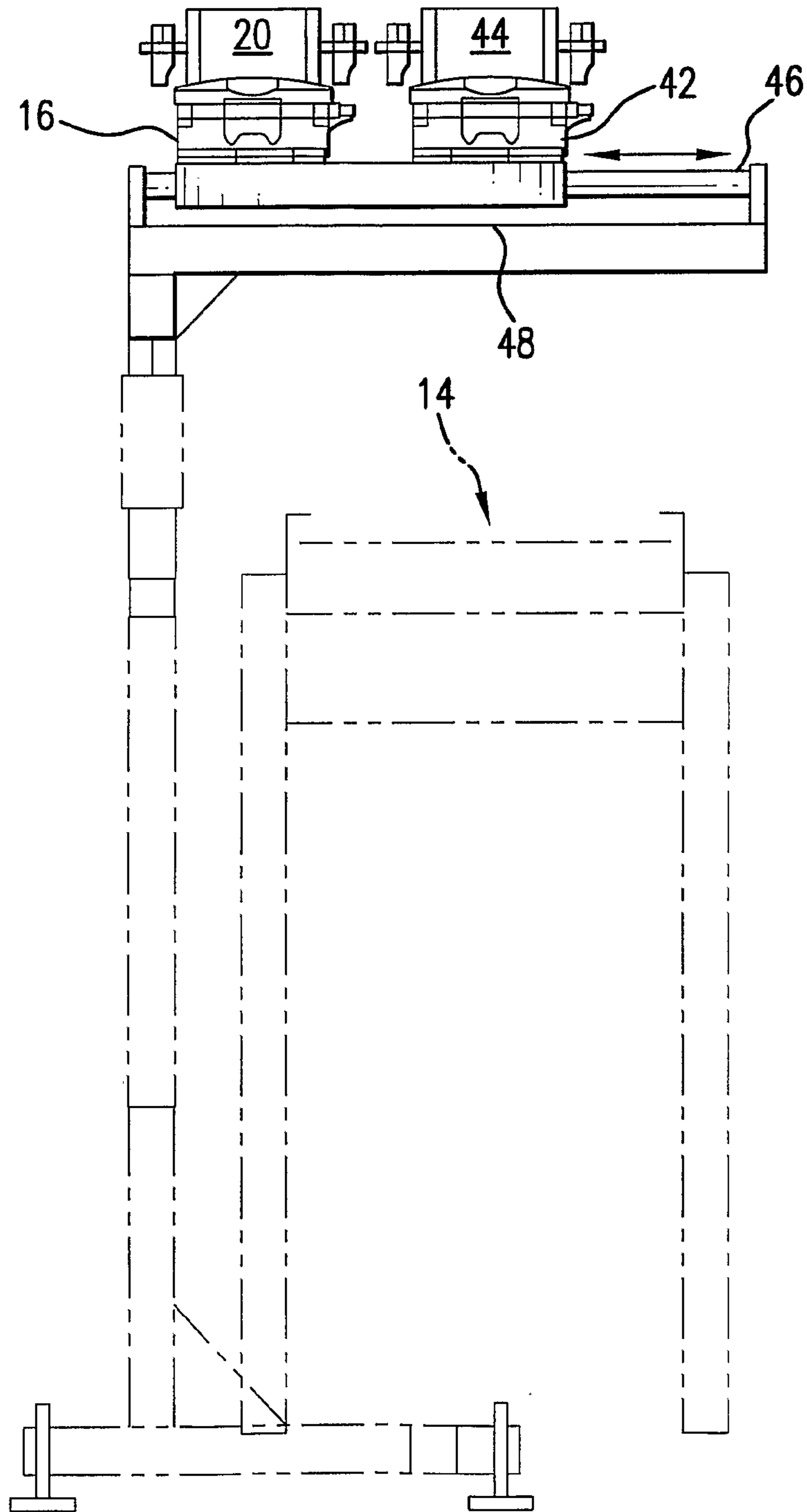

FIG.5

7/21

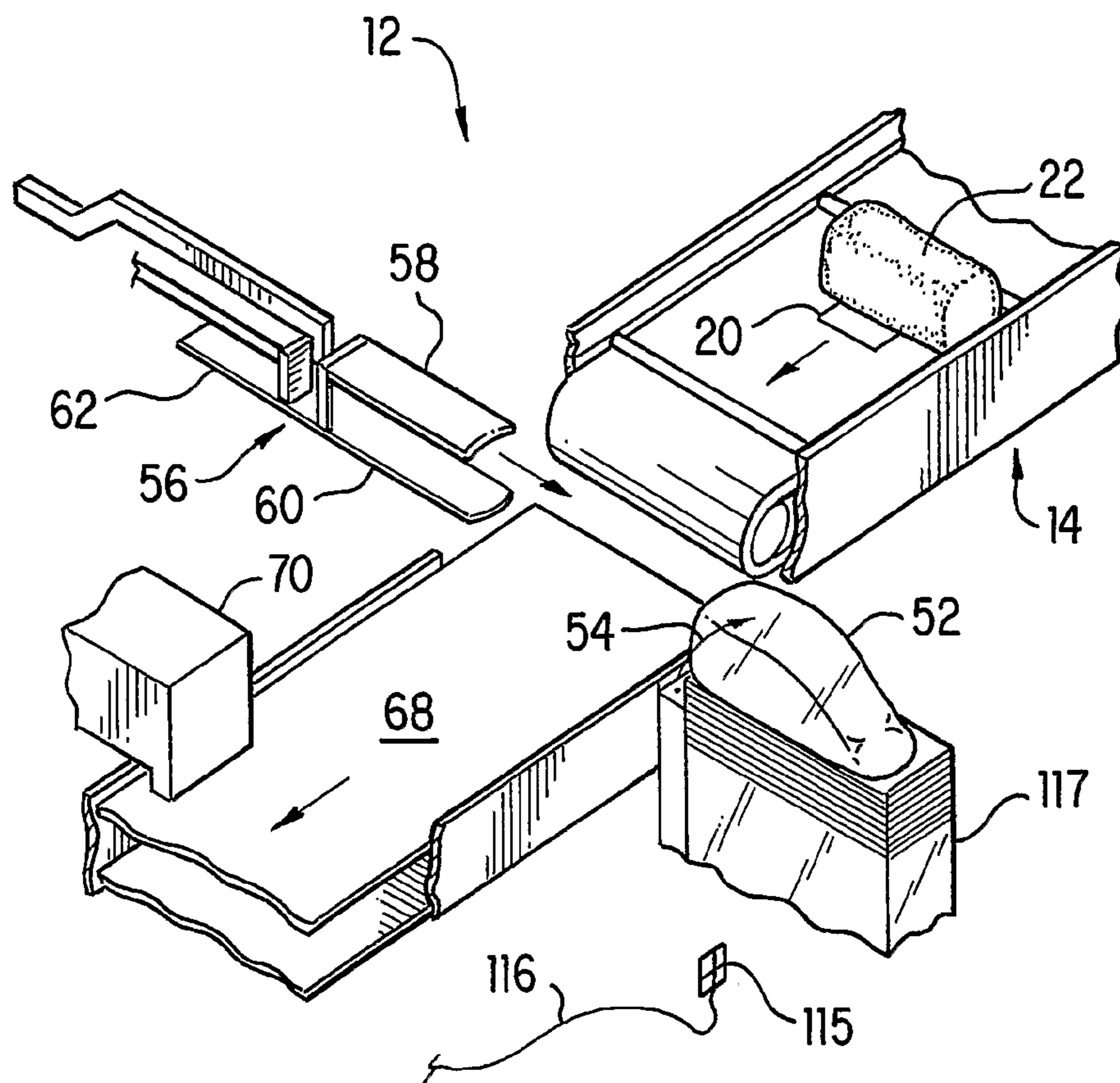

FIG. 6

8/21

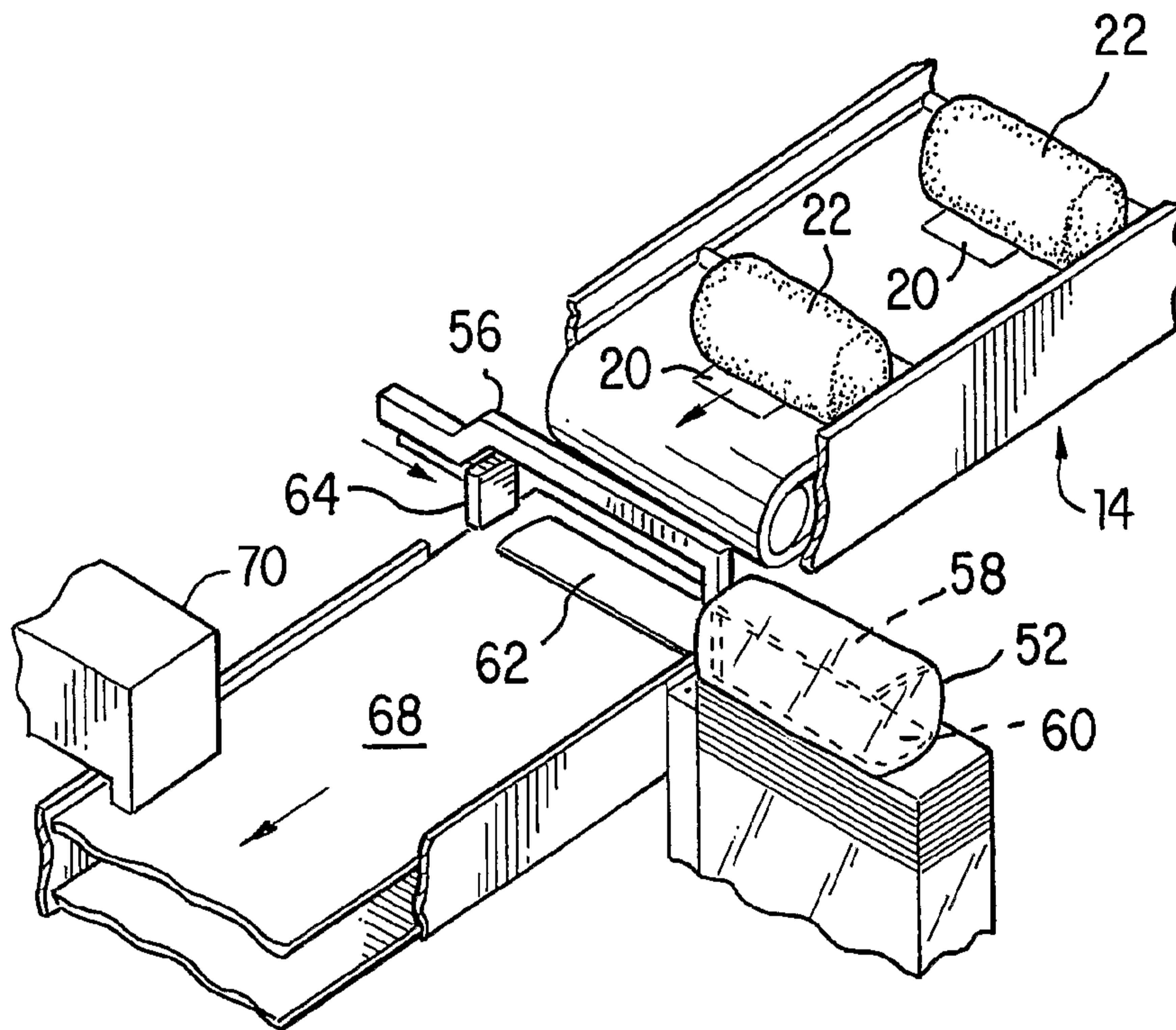

FIG. 7

9/21

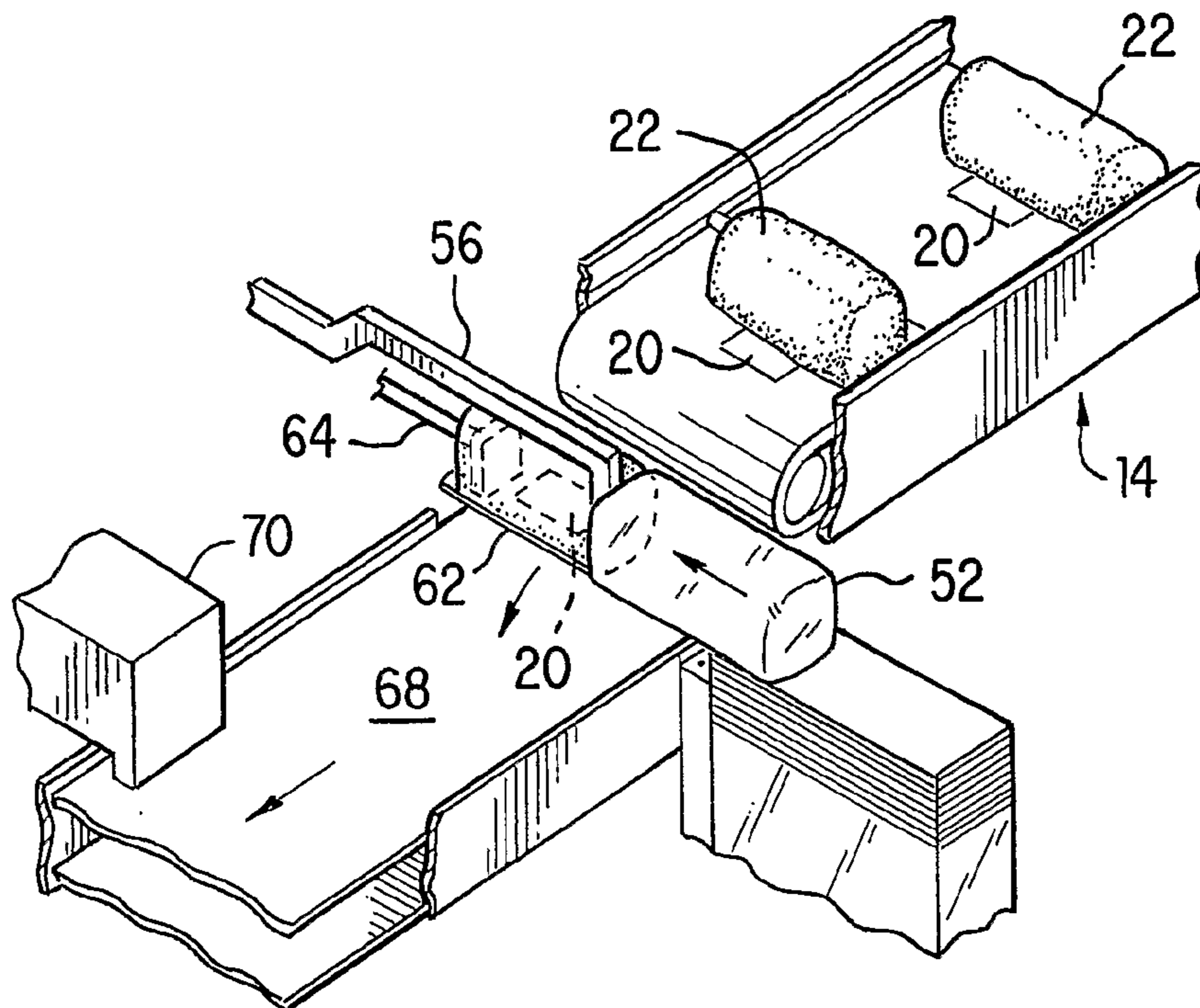

FIG. 8

10/21

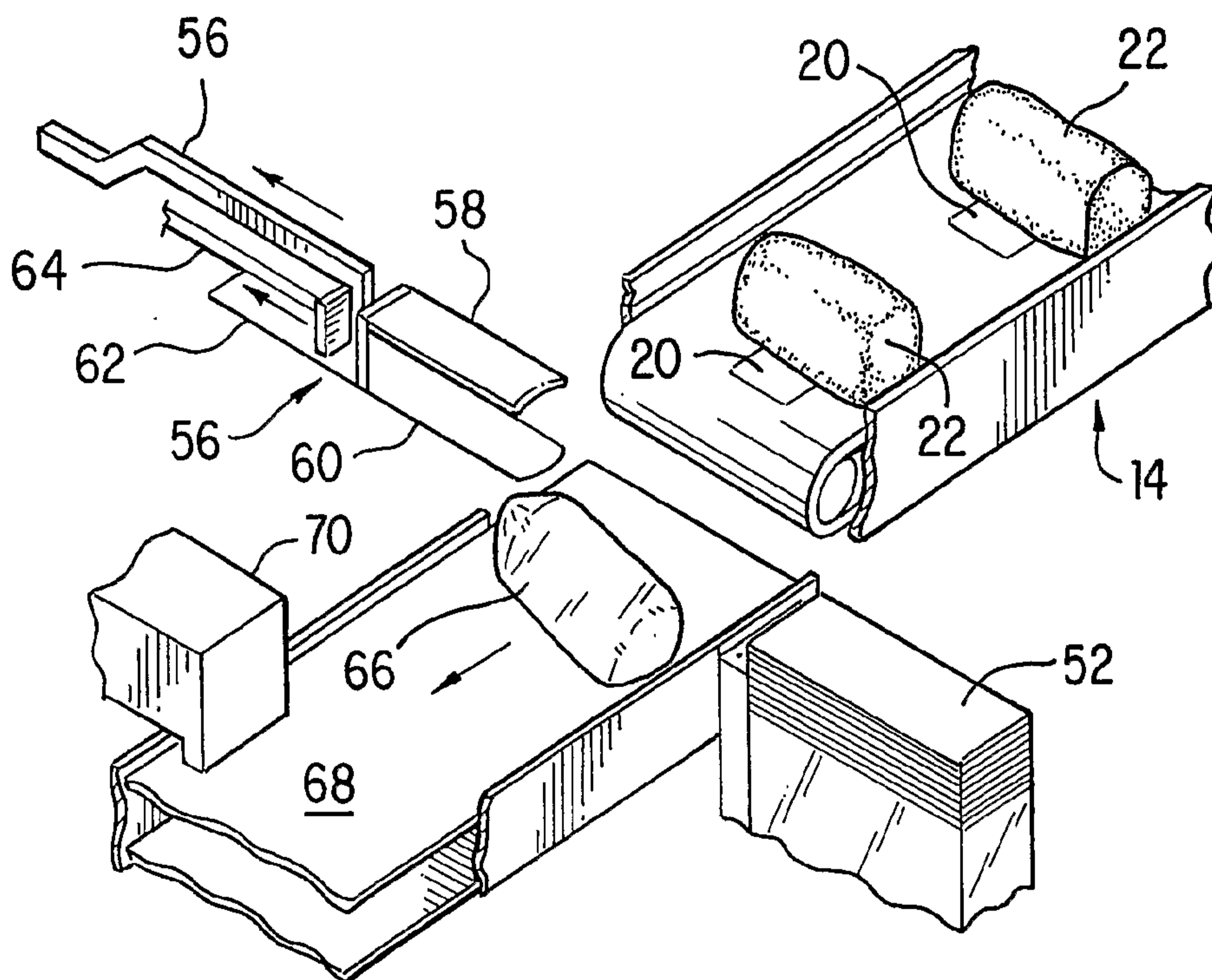

FIG. 9

11/21

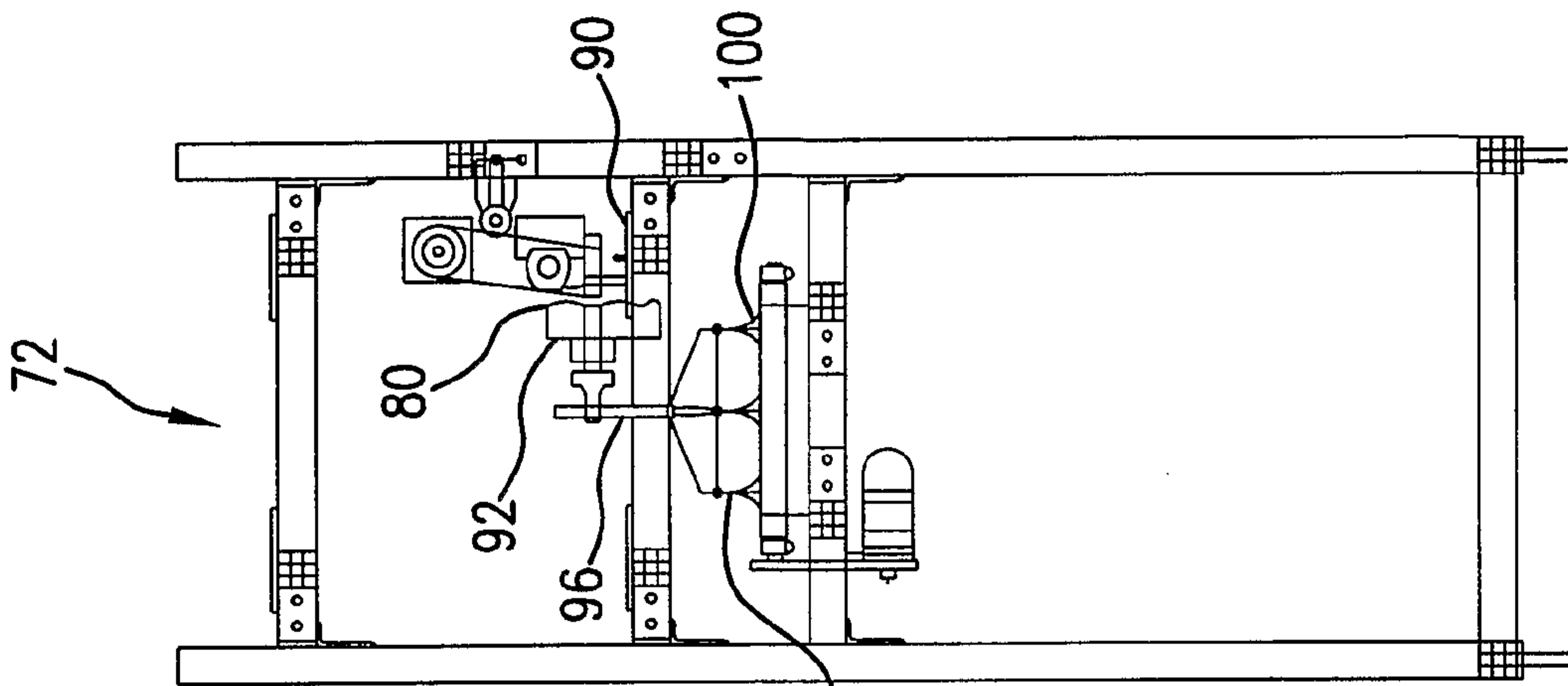

FIG. 11

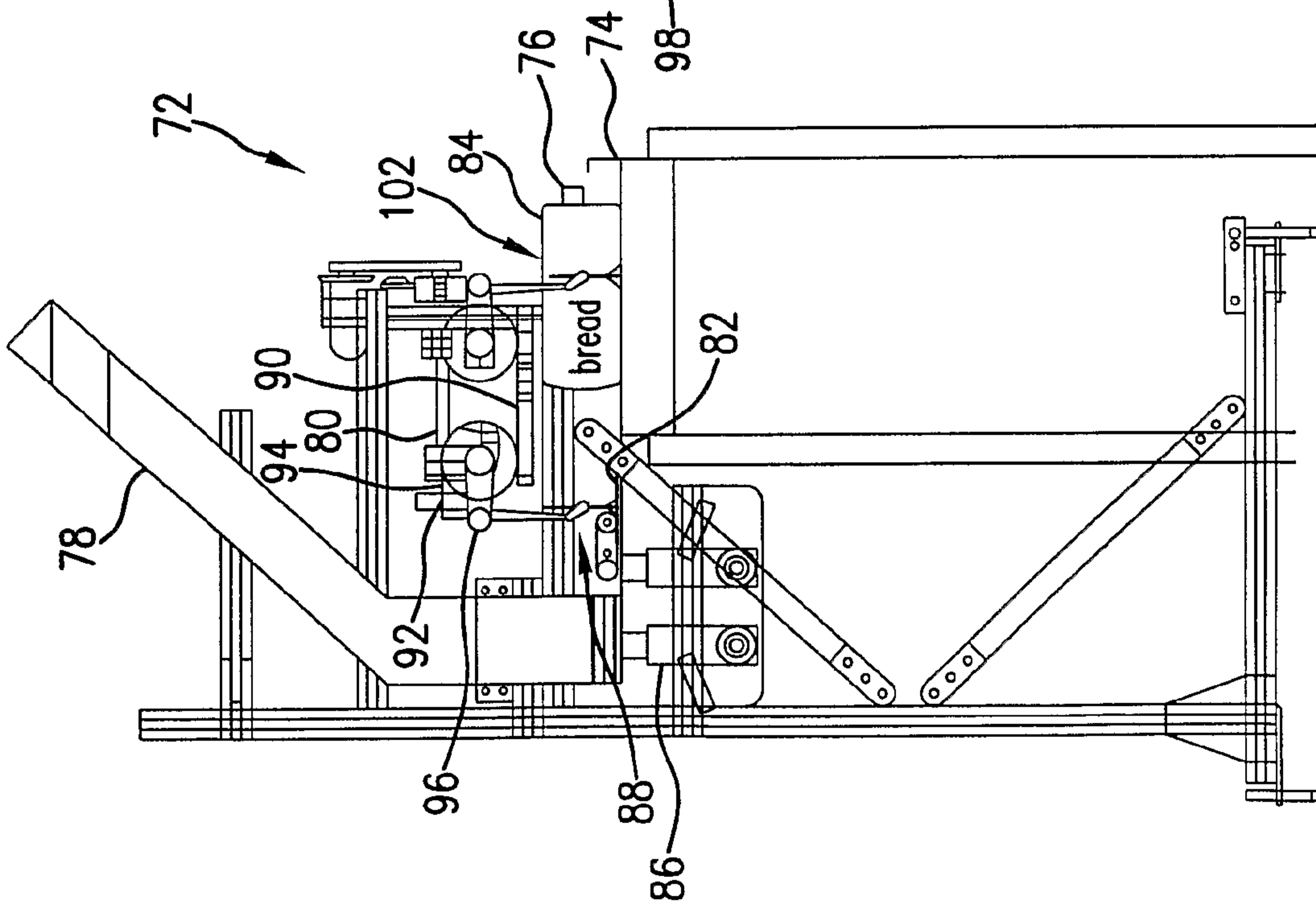

FIG. 10

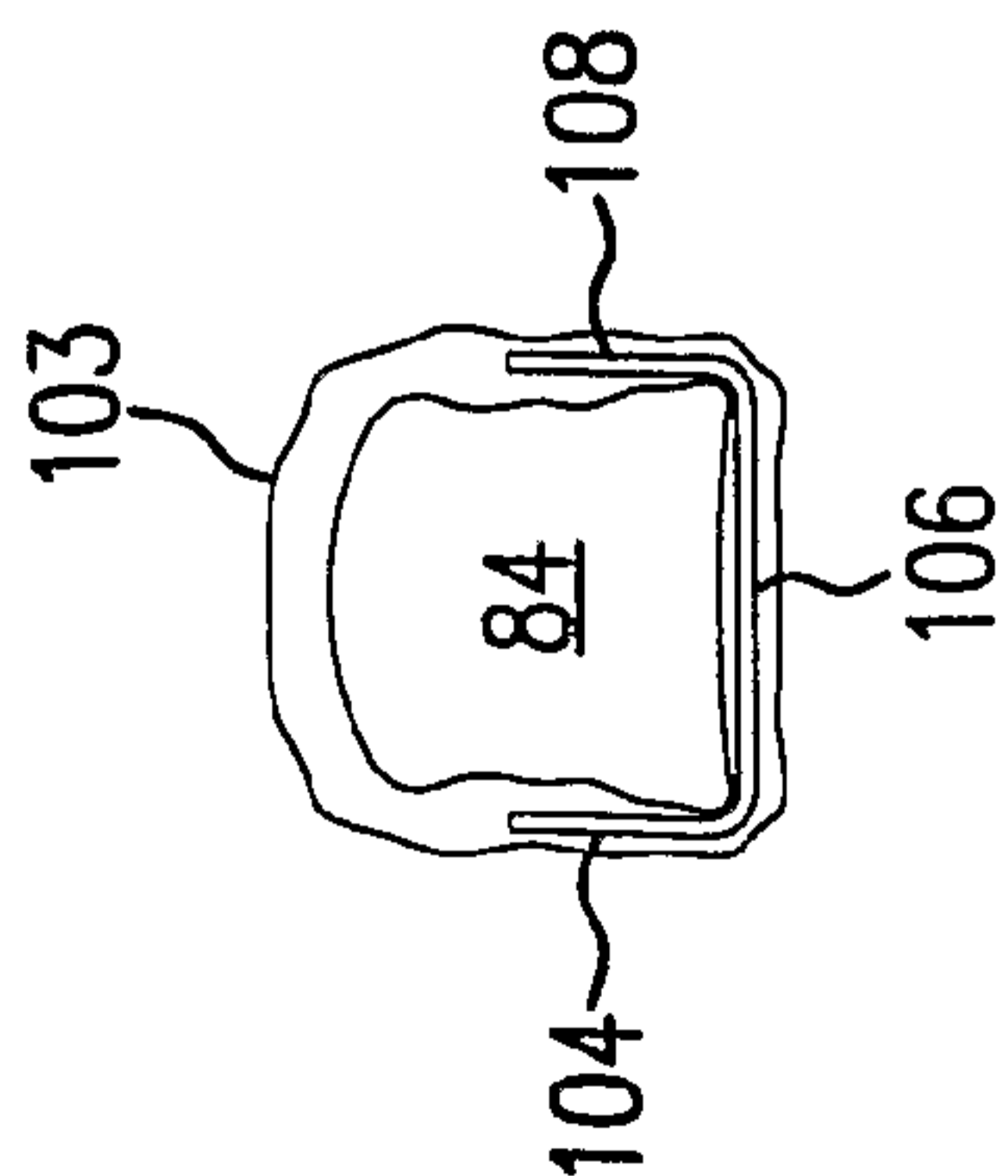

FIG. 12

12/21

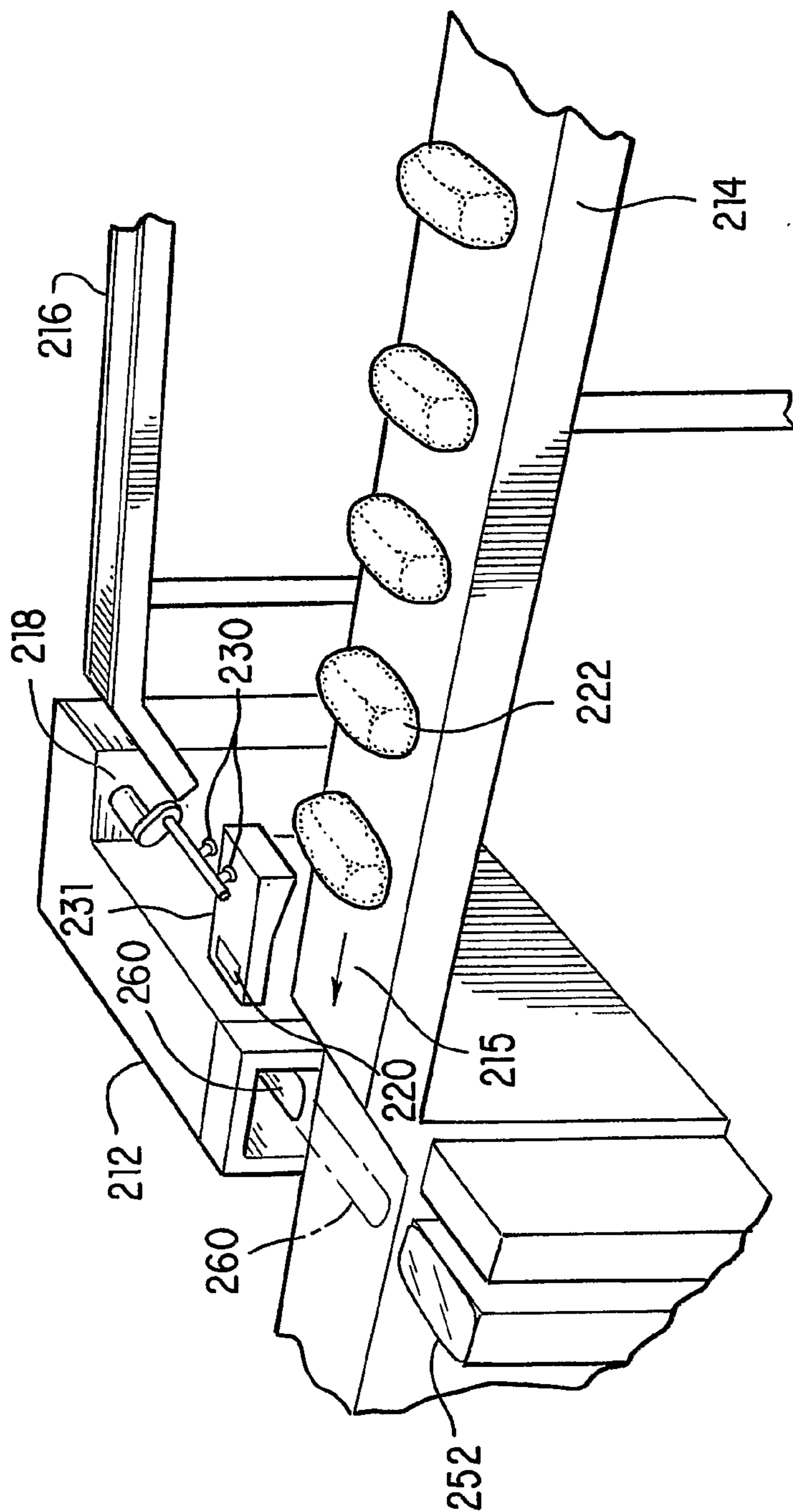

FIG. 13

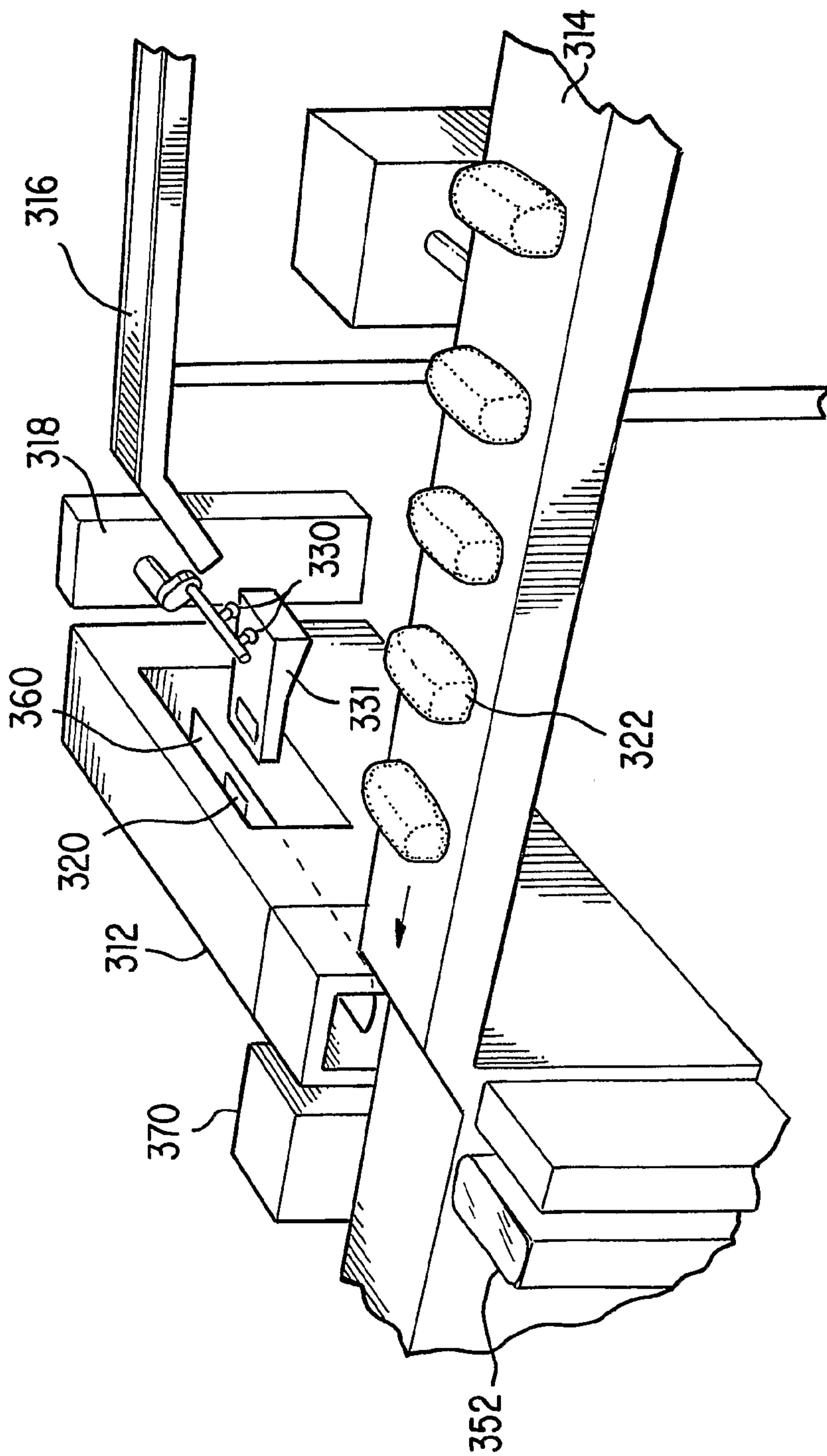

FIG. 14

14/21

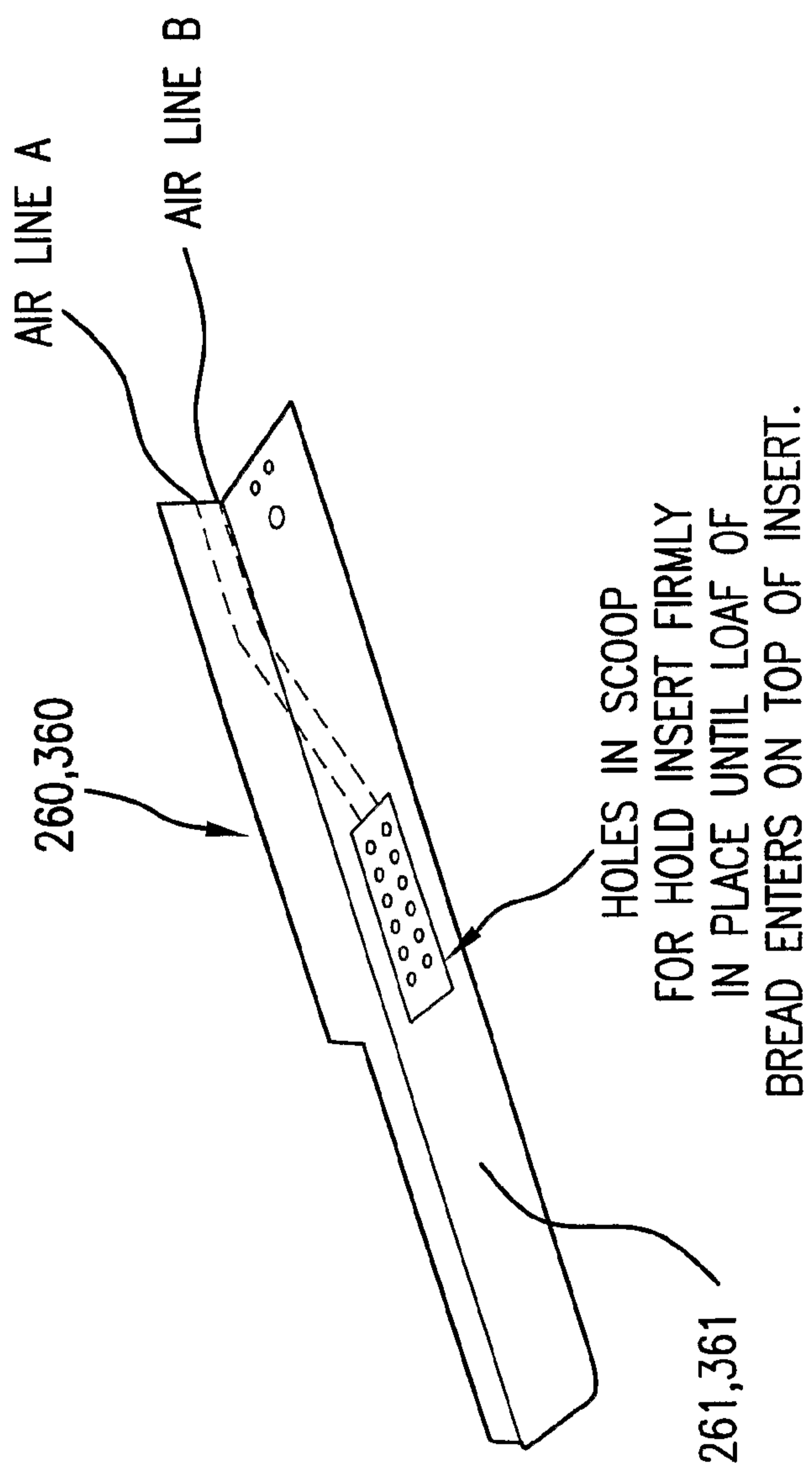

FIG.15

15/21

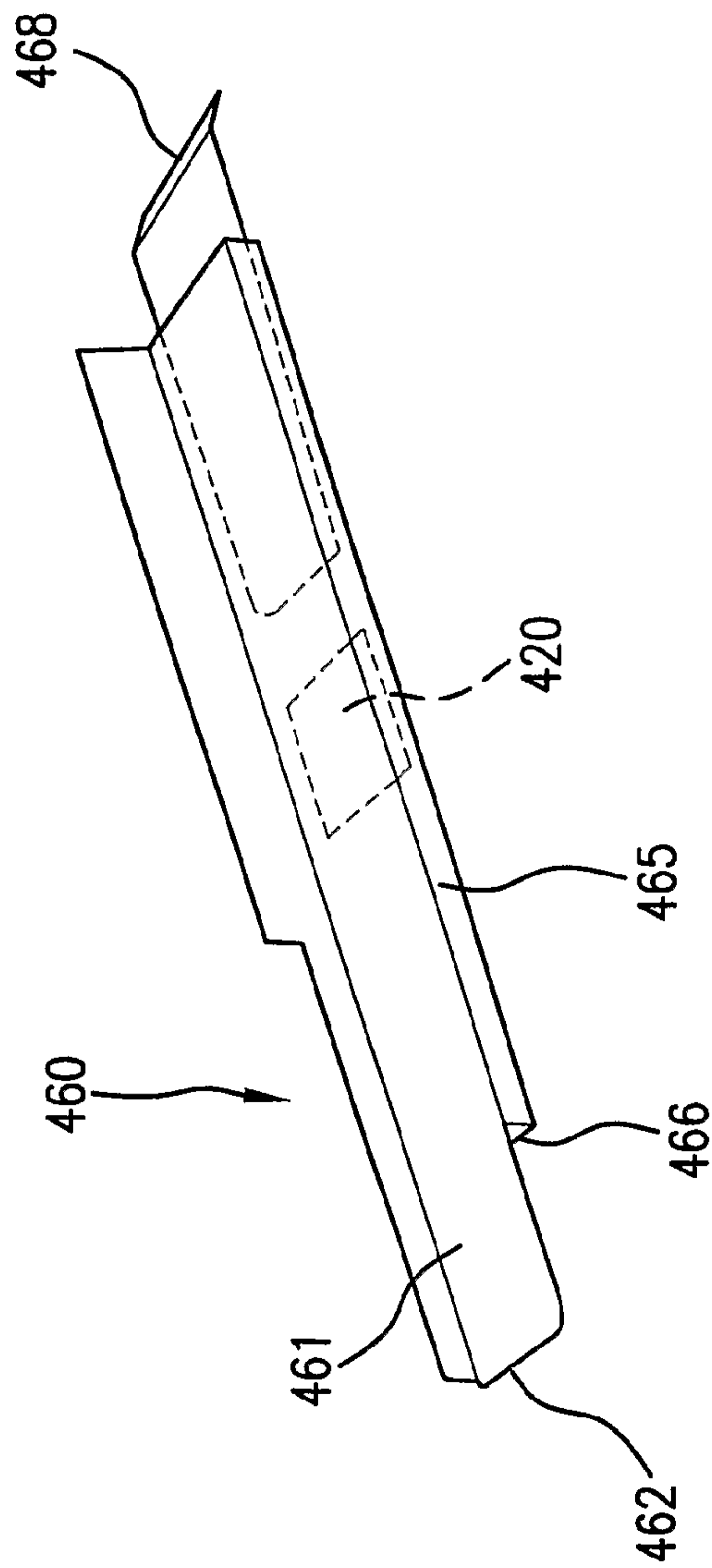

FIG. 16A

16/21

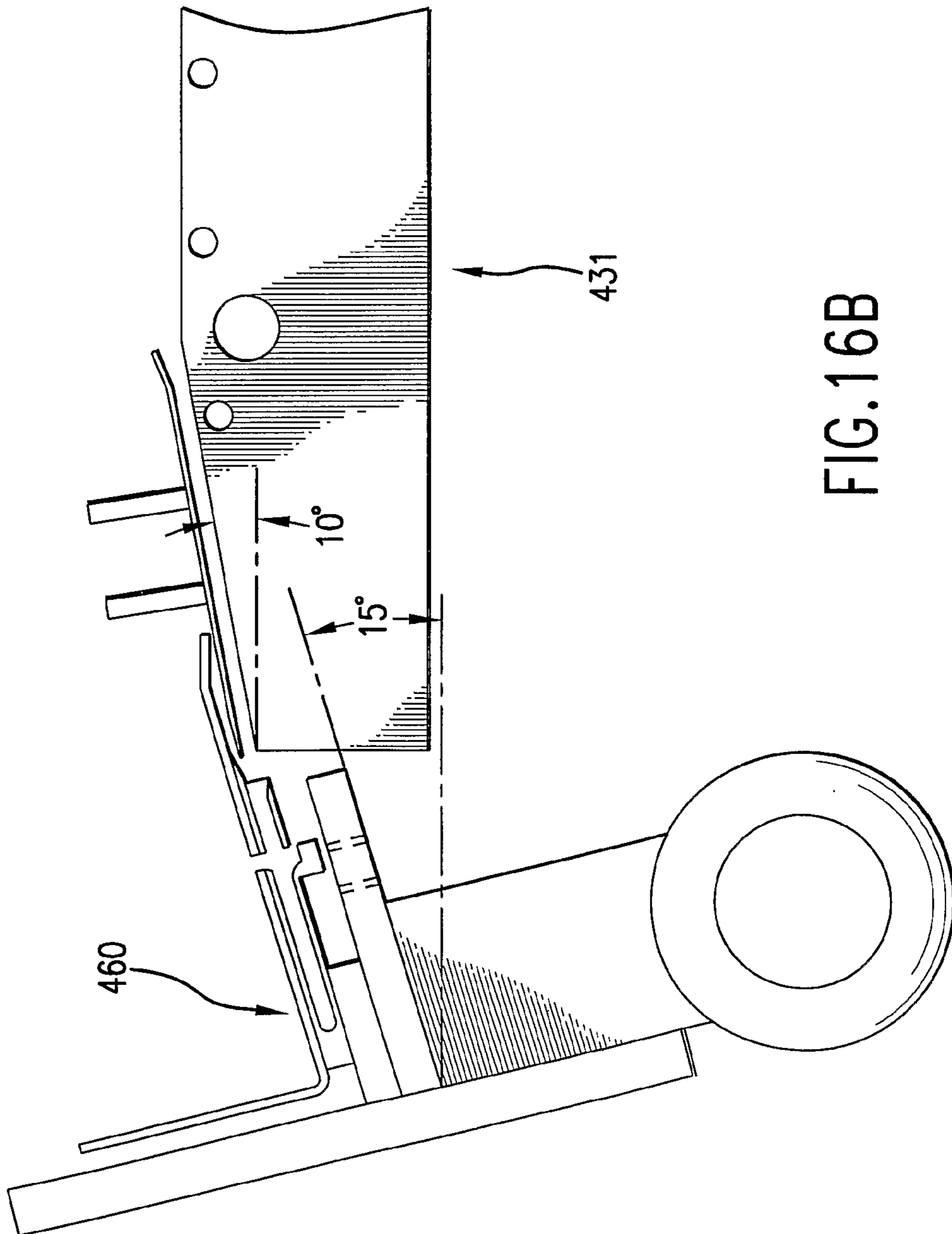

FIG.16B

17/21

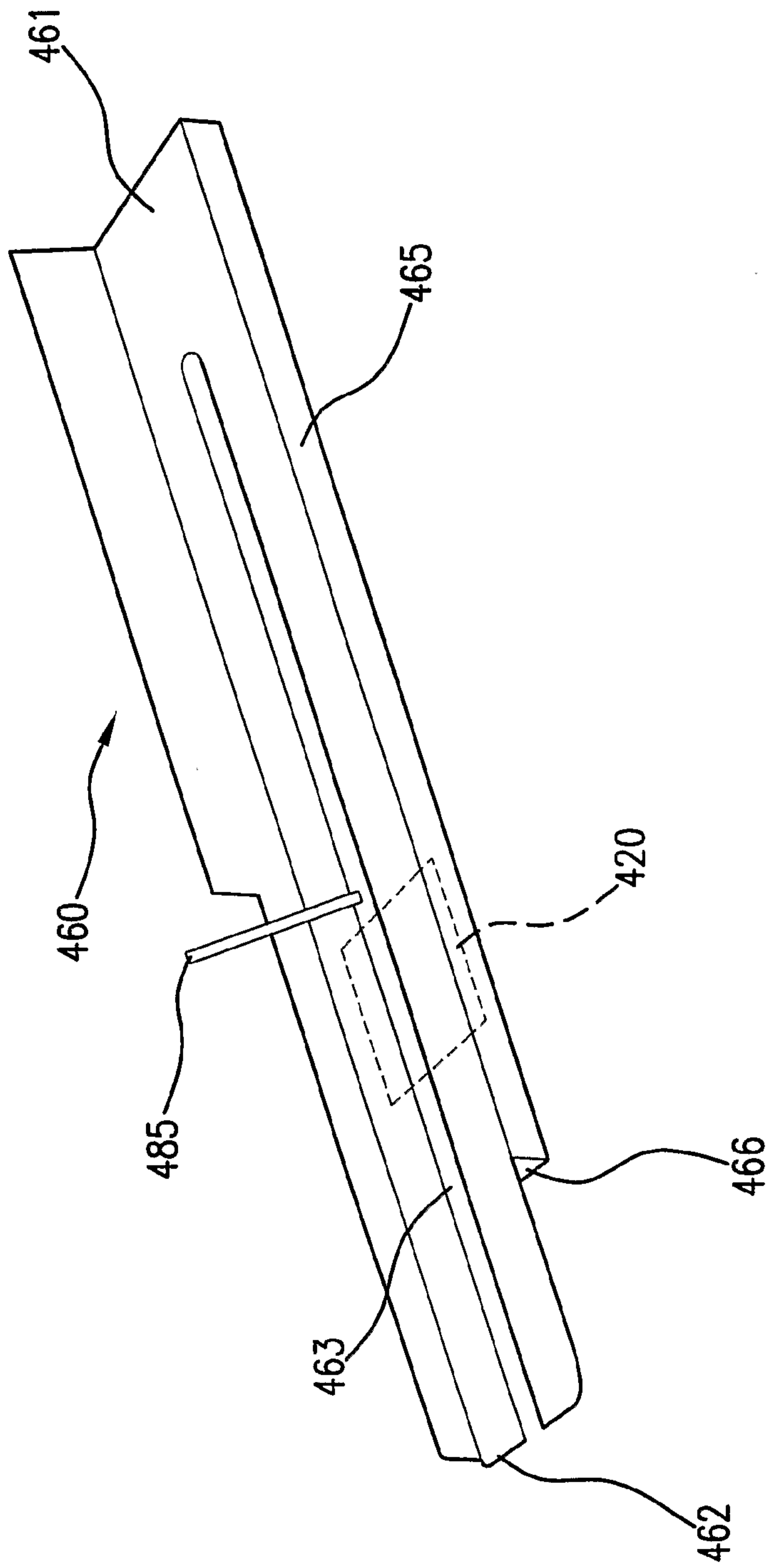

FIG.17A

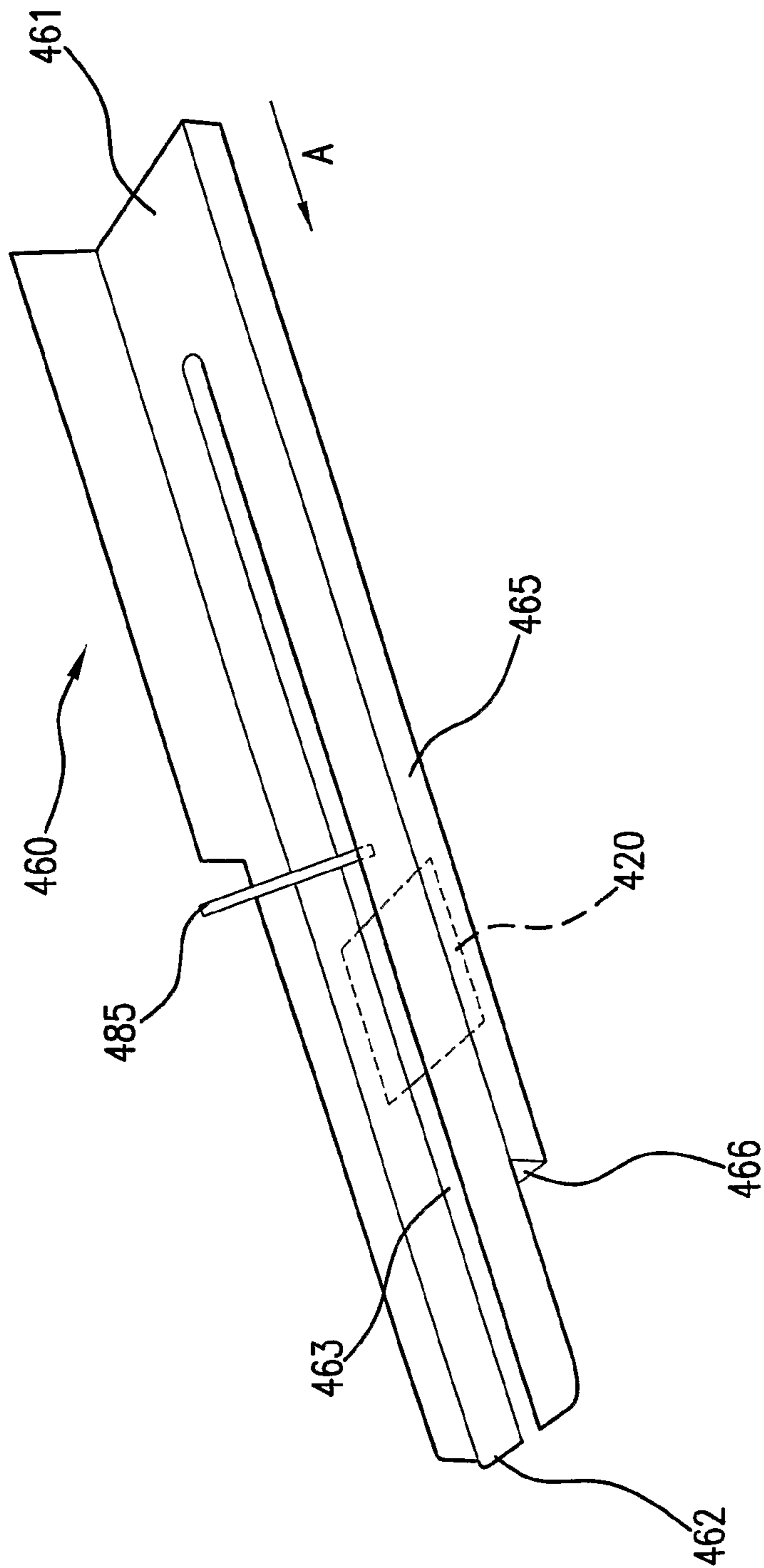

FIG.17B

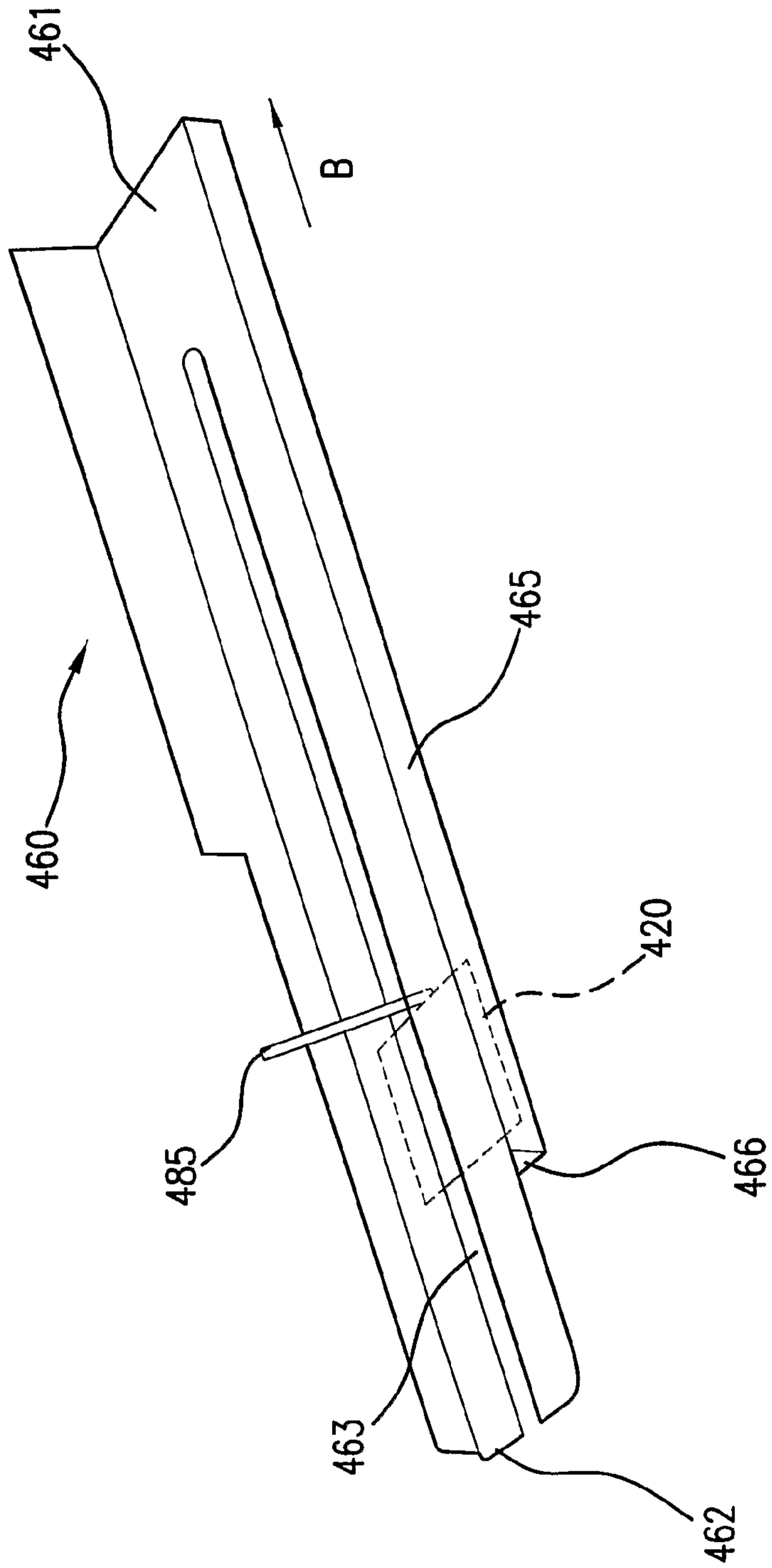

FIG.17C

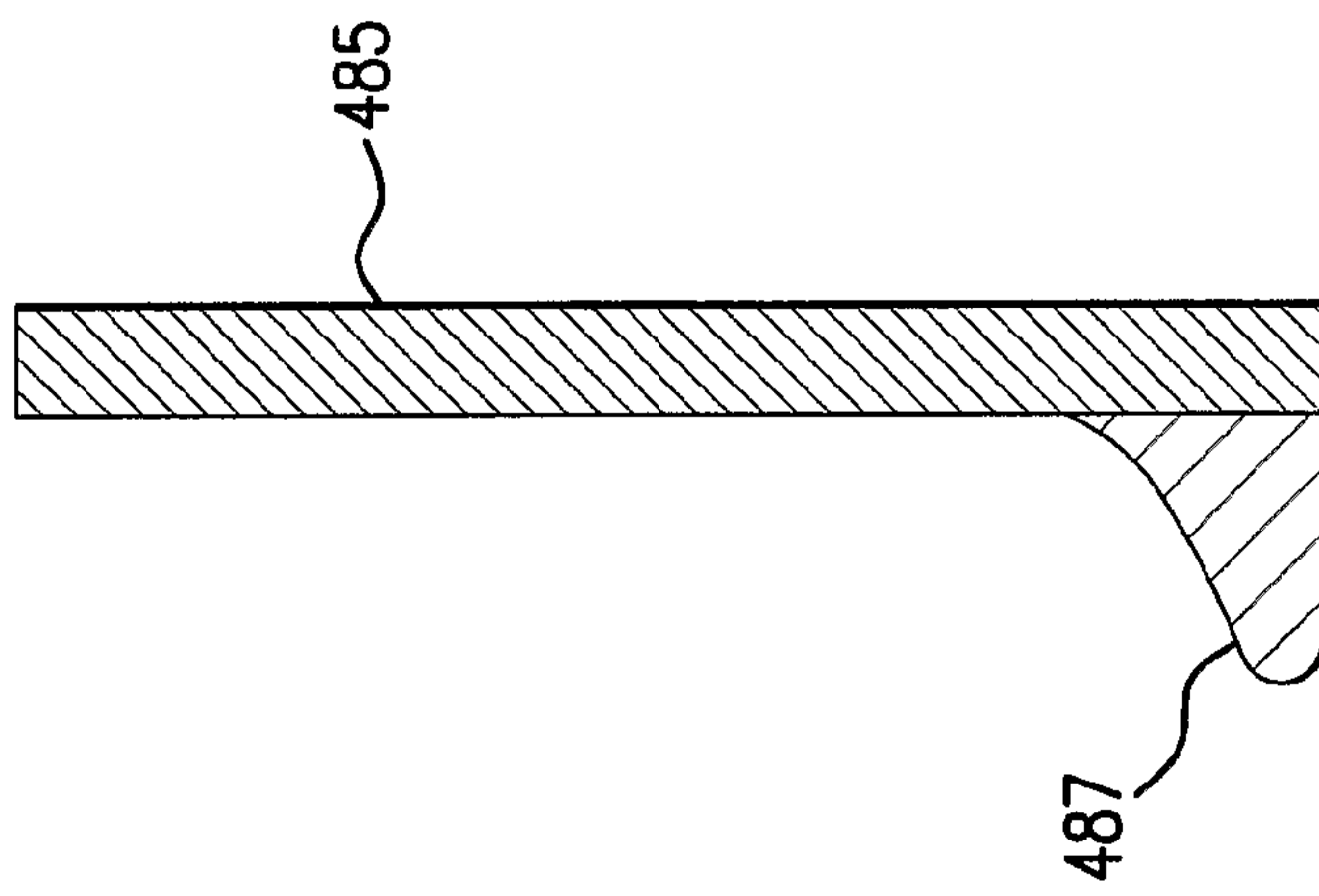

FIG.17D

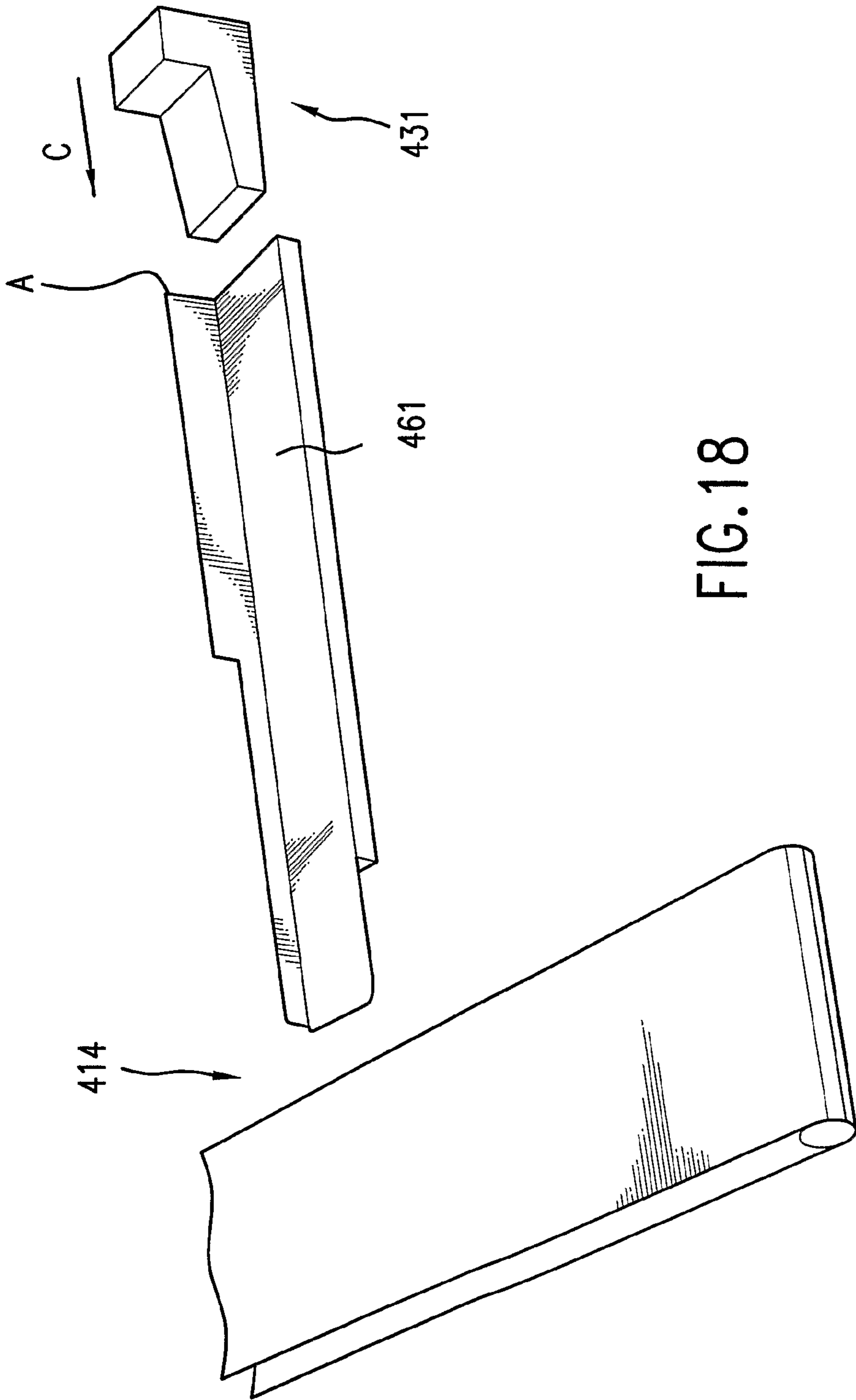

FIG. 18

