

G. H. PHILLIPS.
Cooking Stove.

No. 101,159.

Patented March 22, 1870.

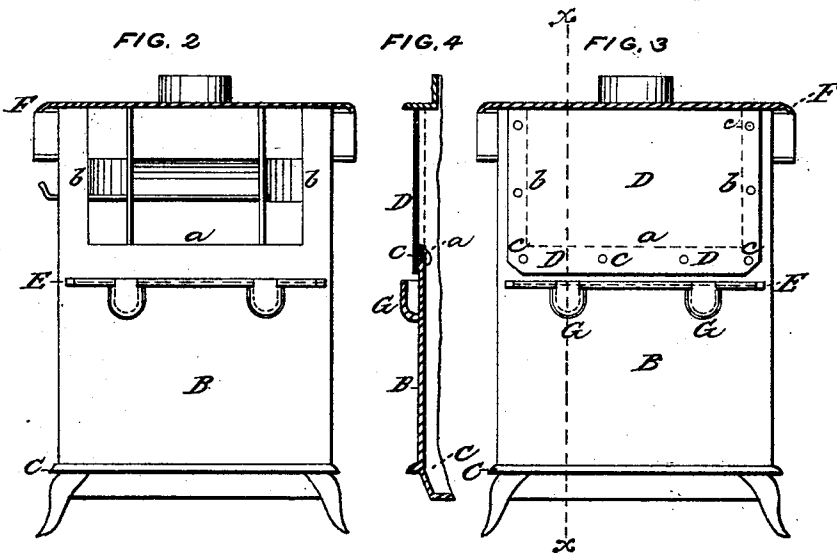
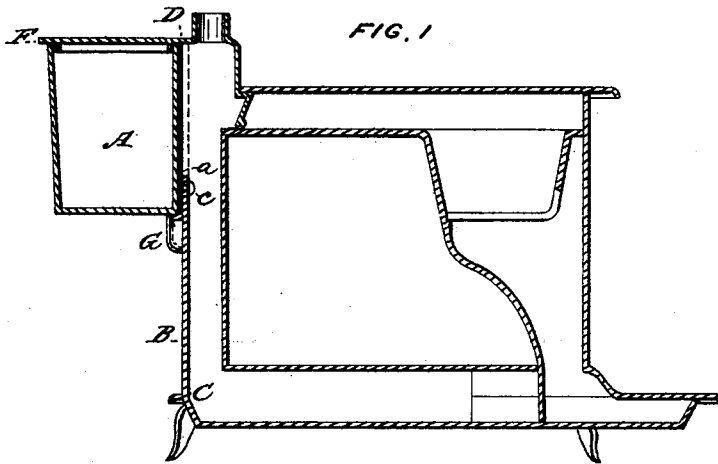

WITNESSES:
L. H. Ripper
C. D. Kellum

INVENTOR:
G. H. Phillips

United States Patent Office.

GEORGE H. PHILLIPS, OF TROY, NEW YORK.

Letters Patent No. 101,159, dated March 22, 1870; antedated February 14, 1870.

IMPROVEMENT IN COOKING-STOVES.

The Schedule referred to in these Letters Patent and making part of the same.

To all whom it may concern :

Be it known that I, GEORGE H. PHILLIPS, of the city of Troy, in the county of Rensselaer and State of New York, have invented certain new and useful Improvements in Cooking-Stoves, and in the arrangement and combination of Boilers or Hot-Water Reservoirs therewith; and I do hereby declare the following to be a full, clear, and exact description thereof, reference being had to the accompanying drawings and to the letters of reference marked thereon making a part of this, my specification.

Like letters represent and refer to like or corresponding parts.

Figure 1 represents a vertical section of a cooking-stove on a center line from front to the rear end of the same, including the water reservoir or boiler, and containing my said invention and improvements, more fully described hereinafter.

Figure 2 represents a cross vertical section between the rear vertical end plate of the stove and the boiler or water-reservoir attached thereto, in the manner and by the means substantially as shown at fig. 1 of the accompanying drawings, and the same will be more at large described hereinafter.

Figure 3 represents the rear vertical end of a cooking-stove having the said boiler or water-reservoir removed, and showing the rear vertical end plate of such stove constructed in part of wrought or sheet-iron, or other sheet metal, and also in part of cast metal, and the two arranged and combined together in the manner and for the purposes substantially as shown in such drawings, and hereinafter described.

Figure 4 represents a cross or edge vertical section of the said rear vertical end plate of the cooking-stove on the line *x*, fig. 3, and showing the cast-iron and sheet-iron or sheet metal part thereof, as well as the manner of combining the two for the reception of the said boiler or water-reservoir, and the placing of the same within the rear end of the cooking-stove, and hereinafter set forth.

The nature of my said invention and improvements consists in the construction of the rear vertical end plate of a cooking-stove in two parts or pieces, and of two kinds of metal, and so combining the same as to receive and operate in connection with a boiler or water-reservoir upon the rear end of such cooking-stove, in the manner and for the purposes substantially as herein described and set forth.

It also consists in constructing and arranging between the rear ascending and descending end flues of a cooking-stove, and the inner side or surface of a boiler or water-reservoir, of the rear vertical end plate constructed at its lower part of cast-iron, and its upper part of thin wrought iron, or sheet-iron, copper, or other sheet metal, and the two united at or near the

lower part or bottom of such cast-iron boiler or water-reservoir by being riveted together, or in some other suitable manner and form, substantially as herein described and set forth.

Were the entire back or rear vertical end plate of the cooking-stove to be constructed of cast-iron, and then the cast-iron boiler or water-reservoir to be placed thereon or against the same in the usual and well-known manner, the water or other matter in said boiler or reservoir would warm or heat too slowly, and thus and thereby retard the usefulness of the same; and were the said back or vertical end plate to be so cut away or removed as to expose the entire inner side of such boiler or reservoir to the direct action of the heat passing in and through the rear vertical end flues of such stove, then such heat would too rapidly heat said boiler, and thus and thereby render the same liable to become cracked or broken, and especially so the enameled surface of such boiler so enameled for the purpose of protecting said boiler from rust while in use, and thereby destroy the usefulness of the same, and rendering it absolutely necessary to warm and heat the water in such boiler or reservoir, before any baking or cooking can be done in and by said cooking-stove, and especially in that part known as the oven. To remedy such defects and disadvantages is the object of my invention and improvements; and which is accomplished by raising the boiler or reservoir vertically upward from the inner or vertical oven-plate, substantially as shown at fig. 1 of accompanying drawings, and also by interposing or constructing and arranging immediately between the rear vertical end flues and the inner side of such reservoir, of a sheet-iron plate or sheet-plate of copper, or other sheet metal, and so arranged that its lower edge and outside vertical edges thereof shall be fastened to that part of such rear vertical end plate as shall have been made of cast-iron in the usual way. It is manifest that the advantages thus gained are:

First, that it protects the said reservoir from the current of heated air or heated escaping products of combustion coming in direct contact with that side of the reservoir next adjoining such stove, whereby it is liable to crack or break and be rendered useless from too sudden expansion, as before stated.

Second, while it thus protects and preserves such boiler or reservoir, it will, at the same time, greatly facilitate the baking and other processes of cooking in the oven of the stove, and heat the water in such reservoir, as such sheet-iron, copper, or other sheet metal are excellent conductors of the heat, and better, and to a much greater degree than cast-iron would be if used in the same place; and

Third, it also protects the oven of the stove from any bad or injurious effects that would be likely to be

produced by and from the water in such boiler or reservoir prior to, and while the same is becoming warmed or heated sufficiently to permit of baking in such oven, as before stated, whereby the process of baking in the oven can be carried on with much greater certainty and rapidity than would be the case were no such intervening plate of sheet metal used in the manner aforesaid; and

Fourth, such plate of sheet metal preserves such boiler or reservoir from being too rapidly worn out by the sudden action of the heat coming in direct and positive contact with the same, as would be the case when no plate of sheet metal is used.

In the accompanying drawings—

A is the boiler or reservoir.

B is that part or portion of the rear vertical end plate made of cast-iron of the usual thickness of stove-plates.

It extends upward from the top of the bottom plate C to and past the front, lower, and inner corner of said boiler A, substantially as shown at *a*, figs. 1 and 2, and by dotted lines *a*, fig. 3.

Upon the outer sides of the stove the said cast-iron part of said plates continues upward to the upper edge of said reservoir, as shown at *b*, fig. 2, and at dotted lines *b b*, fig. 3. Between said parts or pieces there is no cast-iron, but the same is omitted or removed for the purposes substantially as aforesaid, and thereafter such space is covered by means of the sheet-iron, copper, or other sheet-metal back, as shown at D, figs. 1, 3, and 4.

The said sheet-metal back extends from the cross or horizontal rib or flange E cast upon said cast-iron part of said rear end plate, as shown at figs. 2 and 3, up to the under side of the plate F forming the top of the said boiler or reservoir, substantially as shown at figs. 1, 3, and 4.

The said sheet-metal part or portion of said rear vertical back or end plate is fastened to the said cast-iron part or portion by means of the rivets *c c*, figs. 1, 3, and 4, or by any other good and substantial means.

Upon the side of the said cast-iron part of said plate I cast or construct outward projections G G, figs. 1, 3, and 4, which are for the purpose of receiving pins or lugs cast upon the under part of said boiler, and so made to fit in said projections G as to retain and hold the said boiler upon the said rear vertical end of the stove, substantially as shown at fig. 1 of the drawings.

The said sheet metal part or portion of said rear vertical end plate, so made and riveted, or otherwise fastened to that part or portion of said plate made of cast-iron, will, in all cases, be in size to correspond to

and with all that part or size of the said boiler or reservoir next adjoining to said rear end of the said stove.

The dotted lines at fig. 3 represents that part or portion of the cast-iron part of such rear end plate as has been removed for the purpose of receiving the said sheet-metal part or portion, in the manner substantially as aforesaid, thereby reserving enough only for the purpose of receiving and supporting the said sheet-metal part of said rear end plate riveted thereto, in the manner aforesaid, and which is shown by a broad or heavy dark line at fig. 1, and marked D, as aforesaid stated.

Having thus described the nature, construction, and object of my said invention and improvements,

What I claim, and desire to secure by Letters Patent of the United States of America, is—

1. The rear end vertical plate of a cooking-stove, having its upper part constructed of sheet or wrought iron, or other suitable sheet metal, and the lower part thereof constructed of cast-iron, or other suitable cast metal, and the two parts or divisions thus constructed suitably united together, and combined in the manner and for the purposes substantially as herein described and set forth.

2. The employment and arrangement of a vertical plate upon the rear end of a cooking-stove, constructed in part of wrought iron, or other suitable sheet metal, and the residue or remaining part thereof constructed of cast-iron or other suitable cast metal, and the combination of such rear end plate so constructed with the rear ascending and descending flues of such cooking-stove, in the manner substantially as herein described and set forth.

3. The arrangement and combination of the boiler or reservoir A upon and with the rear vertical end plate of a cooking-stove constructed in part of sheet metal and in part of cast metal, substantially as specified in the first and second claims hereof, and in the manner substantially as herein described and set forth.

4. The combination of the boiler or reservoir A with the cast-metal plate B, and with the sheet-metal plate D, forming the rear end vertical plate of a cooking-stove with water-reservoir attached, and combined in the manner substantially as herein described and set forth.

In testimony whereof I have hereto set my hand this 5th day of January, 1870.

G. H. PHILLIPS.

Witnesses:

CHARLES D. KILLUM,
L. H. TUPPER.