



- (51) **International Patent Classification:**
G06F 13/14 (2006.01) G06F 12/16 (2006.01)
G06F 13/16 (2006.01)
- (21) **International Application Number:**
PCT/KR2012/001051
- (22) **International Filing Date:**
13 February 2012 (13.02.2012)
- (25) **Filing Language:** English
- (26) **Publication Language:** English
- (30) **Priority Data:**
13/025,270 11 February 2011 (11.02.2011) US
- (71) **Applicant (for all designated States except US):** TAEJIN INFO TECH CO., LTD. [KR/KR]; 2F Namkyung Bldg., 37 Seobinggo-Dong, Yongsan-Ku, Seoul 140-240 (KR).
- (72) **Inventor; and**
- (75) **Inventor/Applicant (for US only):** CHO, Byungcheol [KR/KR]; 2F Hojeo-Villa, #12-75, Bangbae-dong, Seocho-gu, Seoul 137-814 (KR).
- (74) **Agent:** HWANG, Ilsuk; 9th Floor Clifford Bldg., 1338-23, Seocho-dong, Seocho-gu, Seoul 137-860 (KR).

- (81) **Designated States (unless otherwise indicated, for every kind of national protection available):** AE, AG, AL, AM, AO, AT, AU, AZ, BA, BB, BG, BH, BR, BW, BY, BZ, CA, CH, CL, CN, CO, CR, CU, CZ, DE, DK, DM, DO, DZ, EC, EE, EG, ES, FI, GB, GD, GE, GH, GM, GT, HN, HR, HU, ID, IL, IN, IS, JP, KE, KG, KM, KN, KP, KR, KZ, LA, LC, LK, LR, LS, LT, LU, LY, MA, MD, ME, MG, MK, MN, MW, MX, MY, MZ, NA, NG, NI, NO, NZ, OM, PE, PG, PH, PL, PT, QA, RO, RS, RU, RW, SC, SD, SE, SG, SK, SL, SM, ST, SV, SY, TH, TJ, TM, TN, TR, TT, TZ, UA, UG, US, UZ, VC, VN, ZA, ZM, ZW.
- (84) **Designated States (unless otherwise indicated, for every kind of regional protection available):** ARIPO (BW, GH, GM, KE, LR, LS, MW, MZ, NA, RW, SD, SL, SZ, TZ, UG, ZM, ZW), Eurasian (AM, AZ, BY, KG, KZ, MD, RU, TJ, TM), European (AL, AT, BE, BG, CH, CY, CZ, DE, DK, EE, ES, FI, FR, GB, GR, HR, HU, IE, IS, IT, LT, LU, LV, MC, MK, MT, NL, NO, PL, PT, RO, RS, SE, SI, SK, SM, TR), OAPI (BF, BJ, CF, CG, CI, CM, GA, GN, GQ, GW, ML, MR, NE, SN, TD, TG).

Published:

— without international search report and to be republished upon receipt of that report (Rule 48.2(g))

(54) **Title:** ALARM-BASED BACKUP AND RESTORATION FOR A SEMICONDUCTOR STORAGE DEVICE

[Fig. 4]

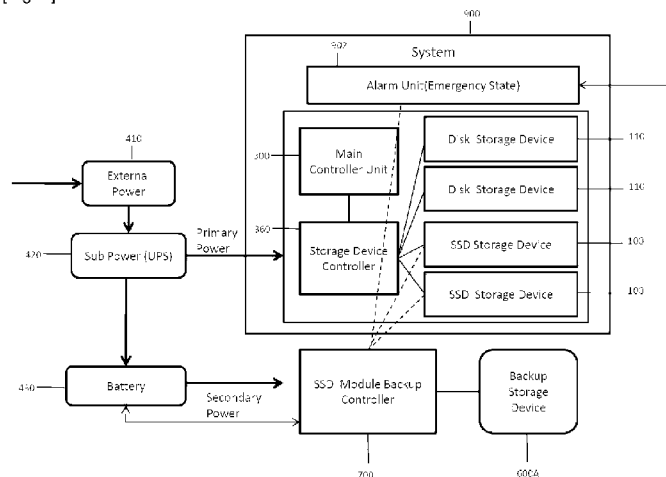

(57) **Abstract:** Embodiments of the present invention provide backup and restoration functions for a storage device of a PCI-Express (PCI-e) type that support a low-speed data processing speed for a host. Specifically, embodiments of this invention provide backup and restoration functions for one or more (i.e., a set of) semiconductor storage devices (SSDs). In general, the present invention provides an alarm unit and a secondary power supply coupled to a backup controller. The backup controller is coupled to a backup storage device. When a primary power supply is deactivated (e.g., fails), an alarm unit and the secondary power supply is activated. In response to this activation, the backup controller will backup any data stored on any SSDs of the storage system (as well as any data stored in main memory of the storage system or in main memory of any host server connected thereto). When the primary power supply is reactivated, the secondary power supply (and the alarm unit) is deactivated, and all data backed up is restored to its original source.

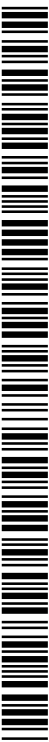

Description

Title of Invention: ALARM-BASED BACKUP AND RESTORATION FOR A SEMICONDUCTOR STORAGE DEVICE

Technical Field

- [1] The present invention relates to a semiconductor storage device of a PCI-Express (PCI-e) type. Specifically, the present invention relates to backup and restoration for a storage device of a PCI-Express type.

Background Art

- [2] **CROSS-REFERENCE TO RELATED APPLICATION**
- [3] This application is related in some aspects to commonly-owned, co-pending application number 12/758,937, entitled "SEMICONDUCTOR STORAGE DEVICE", filed on April 13, 2010, the entire contents of which are herein incorporated by reference. This application is also related in some aspects to commonly-owned, co-pending application number 12/771,136, entitled "BACKUP AND RESTORATION FOR A SEMICONDUCTOR STORAGE DEVICE", filed on April 30, 2010, the entire contents of which are herein incorporated by reference.
- [4] As the need for more computer storage grows, more efficient solutions are being sought. As is known, there are various hard disk solutions that store/read data in a mechanical manner as a data storage medium. Unfortunately, data processing speed associated with hard disks is often slow. Moreover, existing solutions still use interfaces that cannot catch up with the data processing speed of memory disks having high-speed data input/output performance as an interface between the data storage medium and the host. Therefore, there is a problem in the existing area in that the performance of the memory disk cannot be properly utilized.

Disclosure of Invention

Technical Problem

- [5] Embodiments of the present invention provide backup and restoration functions for a storage device of a PCI-Express (PCI-e) type that support a low-speed data processing speed for a host. Specifically, embodiments of this invention provide backup and restoration functions for one or more (i.e., a set of) semiconductor storage devices (SSDs). In general, the present invention provides an alarm unit and a secondary power supply coupled to a backup controller. The backup controller is coupled to a backup storage device. When a primary power supply is deactivated (e.g., fails), an alarm unit and the secondary power supply is activated. In response to this activation, the backup

controller will backup any data stored on any SSDs of the storage system (as well as any data stored in main memory of the storage system or in main memory of any host server connected thereto). When the primary power supply is reactivated, the secondary power supply (and the alarm unit) is deactivated, and all data backed up is restored to its original source.

Solution to Problem

[6] A first aspect of the present invention provides a system for backing up and restoring a semiconductor storage device (SSD), comprising: a secondary power supply coupled to an SSD backup controller (module/unit); an alarm unit coupled to the SSD backup controller; a backup storage device coupled to the SSD backup controller; and at least one SSD memory disk unit coupled to the SSD backup controller, wherein the alarm unit and the secondary power supply is activated in response to a deactivation of a primary power supply, and wherein the backup controller backs up SSD data stored on the at least one SSD memory disk unit to the backup storage device in response to the deactivation of the primary power supply.

[7] A second aspect of the present invention provides a method for backing up and restoring a semiconductor storage device (SSD), comprising: coupling a secondary power supply and an alarm unit to an SSD backup controller; coupling a backup storage device to the SSD backup controller; coupling at least one SSD memory disk unit to the SSD backup controller; activating the alarm unit and secondary power supply in response to a deactivation of a primary power supply; and backing up SSD data stored on the at least one SSD memory disk unit to the backup storage device using the backup controller in response to the deactivation of the primary power supply.

[8] A third aspect of the present invention provides A method for backing up and restoring a semiconductor storage device (SSD), comprising: coupling a secondary power supply and an alarm unit to an SSD backup controller; coupling a backup storage device to the SSD backup controller; coupling at least one SSD memory disk unit to the SSD backup controller; activating the alarm unit and secondary power supply in response to a deactivation of a primary power supply; and backing up SSD data stored on the at least one SSD memory disk unit to the backup storage device using the backup controller in response to the deactivation of the primary power supply.

[9]

Advantageous Effects of Invention

[10] According to the present invention, backup and restoration functions for one or more (i.e., a set of) semiconductor storage devices (SSDs) are provided.

Brief Description of Drawings

- [11] These and other features of this invention will be more readily understood from the following detailed description of the various aspects of the invention taken in conjunction with the accompanying drawings in which:
- [12] Fig. 1 is a diagram schematically illustrating a configuration of a
- [13] storage device of a PCI-Express (PCI-e) type according to an embodiment.
- [14] Fig. 2 is a diagram schematically illustrating a configuration of the high speed SSD of Fig. 1.
- [15] Fig. 3 is a diagram schematically illustrating a configuration of a controller unit in Fig. 1.
- [16] Fig. 4 is a diagram schematically illustrating a configuration of an alarm-based backup and restoration system for an SSD according to an embodiment of the present invention.
- [17] Fig. 5 is a diagram schematically illustrating the alarm-based backup and restoration system of Fig. 4 as implemented within a single SSD system according to an embodiment of the present invention.
- [18] Fig. 6 is a diagram schematically illustrating the alarm-based backup and restoration system of Fig. 4 as implemented within a networked SSD system according to an embodiment of the present invention.
- [19] The drawings are not necessarily to scale. The drawings are merely schematic representations, not intended to portray specific parameters of the invention. The drawings are intended to depict only typical embodiments of the invention, and therefore should not be considered as limiting the scope of the invention. In the drawings, like numbering represents like elements.

Mode for the Invention

- [20] Exemplary embodiments now will be described more fully herein with reference to the accompanying drawings, in which exemplary embodiments are shown. This disclosure may, however, be embodied in many different forms and should not be construed as limited to the exemplary embodiments set forth therein. Rather, these exemplary embodiments are provided so that this disclosure will be thorough and complete and will fully convey the scope of this disclosure to those skilled in the art. In the description, details of well-known features and techniques may be omitted to avoid unnecessarily obscuring the presented embodiments.
- [21] The terminology used herein is for the purpose of describing particular embodiments only and is not intended to be limited to this disclosure. As used herein, the singular forms “a”, “an”, and “the” are intended to include the plural forms as well, unless the context clearly indicates otherwise. Furthermore, the use of the terms “a”, “an”, etc. do

not denote a limitation of quantity, but rather denote the presence of at least one of the referenced items. It will be further understood that the terms “comprises” and/or “comprising”, or “includes” and/or “including”, when used in this specification, specify the presence of stated features, regions, integers, steps, operations, elements, and/or components, but do not preclude the presence or addition of one or more other features, regions, integers, steps, operations, elements, components, and/or groups thereof. Moreover, as used herein, the term RAID means redundant array of independent disks (originally redundant array of inexpensive disks). In general, RAID technology is a way of storing the same data in different places (thus, redundantly) on multiple hard disks. By placing data on multiple disks, I/O (input/output) operations can overlap in a balanced way, improving performance. Since multiple disks increase the mean time between failures (MTBF), storing data redundantly also increases fault tolerance.

- [22] Unless otherwise defined, all terms (including technical and scientific terms) used herein have the same meaning as commonly understood by one of ordinary skill in the art. It will be further understood that terms such as those defined in commonly used dictionaries should be interpreted as having a meaning that is consistent with their meaning in the context of the relevant art and the present disclosure, and will not be interpreted in an idealized or overly formal sense unless expressly so defined herein.
- [23] Hereinafter, a storage device of a PCI-Express (PCI-e) type according to an embodiment will be described in detail with reference to the accompanying drawings.
- [24] Embodiments of the present invention provide backup and restoration functions for a storage device of a PCI-Express (PCI-e) type that support a low-speed data processing speed for a host. Specifically, embodiments of this invention provide backup and restoration functions for one or more (i.e., a set of) semiconductor storage devices (SSDs). In general, the present invention provides an alarm unit and a secondary power supply coupled to a backup controller. The backup controller is coupled to a backup storage device. When a primary power supply is deactivated (e.g., fails), an alarm unit and the secondary power supply is activated. In response to this activation, the backup controller will backup any data stored on any SSDs of the storage system (as well as any data stored in main memory of the storage system or in main memory of any host server connected thereto). When the primary power supply is reactivated, the secondary power supply (and the alarm unit) is deactivated, and all data backed up is restored to its original source.
- [25] The storage device of a PCI-Express (PCI-e) type supports a low-speed data processing speed for a host by adjusting synchronization of a data signal transmitted/received between the host and a memory disk during data communications between the host and the memory disk through a PCI-Express interface, and simultaneously

supports a high-speed data processing speed for the memory disk, thereby supporting the performance of the memory to enable high-speed data processing in an existing interface environment at the maximum. It is understood in advance that although PCI-Express technology will be utilized in a typical embodiment, other alternatives are possible. For example, the present invention could utilize Serial Attached Small Computer System Interface (SAS)/Serial Advanced Technology Advancement (SATA) technology in which a SAS/SATA type storage device is provided that utilizes a SAS/SATA interface.

[26] Referring now to Fig. 1, a diagram schematically illustrating a configuration of a PCI-Express type, RAID controlled semiconductor storage device (e.g., for providing storage for a serially attached computer device) according to an embodiment of the invention is shown. As depicted, Fig. 1 shows a RAID controlled PCI-Express type storage device 110 according to an embodiment of the invention which includes a memory disk unit 100 comprising: a plurality of memory disks having a plurality of volatile semiconductor memories (also referred to herein as high-speed SSDs 100); a RAID controller 800 coupled to SSDs 100; an interface unit 200 (e.g., PCI-Express host) which interfaces between the memory disk unit and a host; a controller unit 300; an auxiliary power source unit 400 that is charged to maintain a predetermined power using the power transferred from the host through the PCI-Express host interface unit; a power source control unit 500 that supplies the power transferred from the host through the PCI-Express host interface unit to the controller unit, the memory disk unit, the backup storage unit, and the backup control unit which, when the power transferred from the host through the PCI-Express host interface unit is blocked or an error occurs in the power transferred from the host, receives power from the auxiliary power source unit and supplies the power to the memory disk unit through the controller unit; a backup storage unit 600A-B that stores data of the memory disk unit; and a backup controller 700 that backs up data stored in the memory disk unit in the backup storage unit, according to an instruction from the host or when an error occurs in the power transmitted from the host; and a redundant array of independent disks (RAID) controller 800 coupled to memory disk unit 100, controller 300, and an internal backup controller 700.

[27] The memory disk unit 100 includes a plurality of memory disks provided with a plurality of volatile semiconductor memories for high-speed data input/output (for example, DDR, DDR2, DDR3, SDRAM, and the like), and inputs and outputs data according to the control of the controller 300. The memory disk unit 100 may have a configuration in which the memory disks are arrayed in parallel.

[28] The PCI-Express host interface unit 200 interfaces between a host and the memory disk unit 100. The host may be a computer system or the like, which is provided with a

PCI-Express interface and a power source supply device.

[29] The controller unit 300 adjusts synchronization of data signals transmitted/received between the PCI-Express host interface unit 200 and the memory disk unit 100 to control a data transmission/reception speed between the PCI-Express host interface unit 200 and the memory disk unit 100.

[30] As depicted, a PCI-e type RAID controller 800 can be directly coupled to any quantity of SSDs 100. Among other things, this allows for optimum control of SSDs 100. The use of a RAID controller 800:

[31] 1. Supports the current backup/restore operations.

[32] 2. Provides additional and improved backup function by performing the following:

[33] a) the internal backup controller 700 determines the backup

[34] (user 's request order or the status monitor detects power supply problems);

[35] b) the internal backup controller 700 requests a data backup to SSDs;

[36] c) the internal backup controller 700 requests an internal backup device to backup data immediately;

[37] d) the internal backup controller 700 monitors the status of the backup for the SSDs and internal backup controller; and

[38] e) the internal backup controller 700 reports the internal backup controller's status and end-op.

[39] 3. Provides additional and improved restore function by performing the following:

[40] a) the internal backup controller 700 determines the restore (user's request order or the status monitor detects power supply problems);

[41] b) the internal backup controller 700 requests a data restore to the SSDs;

[42] c) the internal backup controller 700 requests an internal backup device to restore data immediately;

[43] d) the internal backup controller 700 monitors the status of the restore for the SSDs and internal backup controller; and

[44] e) the internal backup controller 700 reports the internal backup controller status and end-op.

[45] Referring now to Fig. 2, a diagram schematically illustrating a configuration of the high speed SSD 100 is shown. As depicted, SSD/memory disk unit 100 comprises: a host interface 202 (e.g., PCI-Express host) (which can be interface 200 of Fig. 1, or a separate interface as shown); a Direct Memory Access (DMA) controller 302 interfacing with a backup controller 700; an ECC controller; and a memory controller 306 for controlling one or more blocks 604 of memory 602 that are used as high-speed storage. Also shown are backup controller 700 coupled to DMA controller 302 and backup storage unit 600A coupled to backup controller 700.

[46] In general, DMA is a feature of modern computers and microprocessors that allows

certain hardware subsystems within the computer to access system memory for reading and/or writing independently of the central processing unit. Many hardware systems use DMA including disk drive controllers, graphics cards, network cards, and sound cards. DMA is also used for intra-chip data transfer in multi-core processors, especially in multiprocessor system-on-chips, where its processing element is equipped with a local memory (often called scratchpad memory) and DMA is used for transferring data between the local memory and the main memory. Computers that have DMA channels can transfer data to and from devices with much less CPU overhead than computers without a DMA channel. Similarly, a processing element inside a multi-core processor can transfer data to and from its local memory without occupying its processor time and allowing computation and data transfer concurrency.

[47] Without DMA, using programmed input/output (PIO) mode for communication with peripheral devices, or load/store instructions in the case of multi-core chips, the CPU is typically fully occupied for the entire duration of the read or write operation, and is thus unavailable to perform other work. With DMA, the CPU would initiate the transfer, do other operations while the transfer is in progress, and receive an interrupt from the DMA controller once the operation has been done. This is especially useful in real-time computing applications where not stalling behind concurrent operations is critical.

[48] Referring now to Fig. 3, the controller unit 300 of Fig. 1 is shown as comprising: a memory control module 310 which controls data input/output of the memory disk unit 100; a DMA control module 320 which controls the memory control module 310 to store the data in the memory disk unit 100, or reads data from the memory disk unit 100 to provide the data to the host, according to an instruction from the host received through the PCI-Express host interface unit 200; a buffer 330 which buffers data according to the control of the DMA control module 320; a synchronization control module 340 which, when receiving a data signal corresponding to the data read from the memory disk unit 100 by the control of the DMA control module 320 through the DMA control module 320 and the memory control module 310, adjusts synchronization of a data signal so as to have a communication speed corresponding to a PCI-Express communications protocol to transmit the synchronized data signal to the PCI-Express host interface unit 200, and, when receiving a data signal from the host through the PCI-Express host interface unit 200, adjusts synchronization of the data signal so as to have a transmission speed corresponding to a communications protocol (for example, PCI, PCI-x, or PCI-e, and the like) used by the memory disk unit 100 to transmit the synchronized data signal to the memory disk unit 100 through the DMA control module 320 and the memory control module 310; and a high-speed interface module 350 which processes the data transmitted/received between the synchro-

nization control module 340 and the DMA control module 320 at high speed. Here, the high-speed interface module 350 includes a buffer having a double buffer structure and a buffer having a circular queue structure, and processes the data transmitted/received between the synchronization control module 340 and the DMA control module 320 without loss at high speed by buffering the data and adjusting data clocks.

- [49] Referring now to Figs. 4-6, a more detailed diagram of a backup and restoration system for a SSD is shown. As first depicted in Fig. 4, system 900 is shown comprising: an alarm unit 902 coupled to backup controller 700; and a main controller unit 300 coupled to a storage device controller 360, which itself is coupled to disk storage units 110, and a set (one or more) of SSD memory disk units (hereinafter SSDs 100). Fig 4 further shows a primary power supply 410 coupled to an uninterruptable power supply (UPS 420) for providing primary power to system 900. Still yet, under the present invention a secondary power supply 430 is coupled to SSD backup controller 700, a backup storage device 600A, and an at least one SSD memory disk unit 100.
- [50] In general, alarm unit 902 and secondary power supply 430 is activated in response to a deactivation of primary power supply 410. When this happens, backup controller 700 backs up SSD data stored on the SSDs 100 to backup storage device 600A. Under this embodiment, secondary power supply 430 (and optionally alarm unit 902) is deactivated when the backup of the SSD data is complete. Then, when primary power supply 410 is reactivated, backup controller 700 restores the SSD data to the SSDs 100 from backup storage device 600A.
- [51] This embodiment is shown in greater detail in conjunction with the single SSD system 910 of Fig. 5. Similar to system 900 of Fig. 4, system 910 comprises: an alarm unit 902 coupled to SSD backup controller 700; a main controller unit 300 coupled to a storage device controller 360, which itself is coupled to main memory (cache) 120, a flash SSD 130, a high density drive (HDD) 140, and a double data rate (DDR) SSD 150. Fig 5 further shows a primary power supply 410 coupled to an uninterruptable power supply (UPS 420) for providing primary power to system 910. Still yet, under the present invention a secondary power supply 430 is coupled to SSD backup controller 700 and a backup storage device 600A, as well as main memory 120 and DDR SSD 150.
- [52] In general, alarm unit 902 and secondary power supply 430 is activated in response to a deactivation of primary power supply 410. When this happens, backup controller 700 backs up SSD data stored on the SSDs 100 (see Fig. 4), as well as main memory data from main memory 120 to backup storage device 600A. Under this embodiment, secondary power supply 430 (and optionally alarm unit 902) is deactivated when the backup of the SSD data is complete. Then, when primary power supply 410 is re-

activated, backup controller 700 restores the SSD data to the SSDs 100 and main memory data to main memory 120 from backup storage device 600A.

[53] Fig. 6 shows these concepts in a more complex networked scenario. As depicted, a host server 920 is coupled to a storage system 930. Storage system 930 comprises: an alarm unit 902A coupled to SSD backup controller 700; and a storage controller 370 coupled to a storage device controller 360, which itself is coupled to main memory (cache) 120, a flash SSD 130, a high density drive (HDD) 140, and a double data rate (DDR) SSD 150. Host server 920 comprises: an alarm unit 902B coupled to SSD backup controller 700; and a main controller unit 300 coupled to a storage device controller 360, which itself is coupled to main memory (cache) 120, a flash SSD 130, a high density drive (HDD) 140, and a fibre channel (FC) controller 160.

[54] Fig. 6 further shows a primary power supply 410 coupled to an uninterruptible power supply (UPS 420) for providing primary power to host server 920 and storage system 930. Still yet, under the present invention, a secondary power supply 430 is coupled to an SSD backup controller 700, a backup storage device 600A, main memory 120 and DDR SSD 150 of storage system 930, and main memory 120 of host server 920.

[55] In general, alarm units 902A-B and secondary power supply 430 are activated in response to a deactivation of primary power supply 410. When this happens, backup controller 700 backs up SSD data stored on the SSDs 100, storage system data from main memory 120 of storage system 930, and server data from main memory 120 of host server 920 to backup storage device 600A. Under this embodiment, secondary power supply 430 (and optionally alarm units 902A-B) is deactivated when the backup of the SSD data is complete. Then, when primary power supply 410 is reactivated, backup controller 700 restores the SSD data, the storage system data, and the server data to the SSDs 100, main memory 120 of storage system 930, and main memory 120 of host server 920, respectively

[56] These operations are further described in the flow shown below:

[57] 1. Normal Operation

[58] a. AC power supplied the power to the sub power(UPS) device

[59] b. The sub power (UPS) recharges volatile device backup batteries.

[60] c. System uses the sub power (UPS) to run the system.

[61] d. This battery is not used for the normal operation. It uses the primary power to recharge the battery.

[62] e. The secondary power is not used in order to save the power.

[63] 2. Emergency Operation

[64] a. Backup

[65] i. AC power off a sub power (UPS) power supply off -a the secondary power supply

- (battery) and alarm unit activate.
- [66] ii. Secondary power will supply the DC power to the SSD module backup controller, and the backup storage device.
- [67] iii. The SSD module backup controller will automatically backup the data from the SSD device to the backup storage device. When the backup is completed, it signals to the battery that the operation is completed.
- [68] iv. The battery system stops the secondary power supply.
- [69] b. Restore
- [70] i. When AC power is restored, the primary power supply is reconnected by the sub power (UPS). When the primary power supply is active, then the battery system senses it and notifies the backup controller
- [71] ii. SSD module backup controller restores the data from the backup storage device to the SSD storage device.
- [72] iii. When restored, it sends a signal to the battery system and the battery stops the secondary power and alarm unit.
- [73] Referring back to Fig. 1, auxiliary power source unit 400 may be configured as a rechargeable battery or the like, so that it is normally charged to maintain a predetermined power using power transferred from the host through the PCI-Express host interface unit 200 and supplies the charged power to the power source control unit 500 according to the control of the power source control unit 500.
- [74] The power source control unit 500 supplies the power transferred from the host through the PCI-Express host interface unit 200 to the controller unit 300, the memory disk unit 100, the backup storage unit 600A-B, and the backup control unit 700.
- [75] In addition, when an error occurs in a power source of the host because the power transmitted from the host through the PCI-Express host interface unit 200 is blocked, or the power transmitted from the host deviates from a threshold value, the power source control unit 500 receives power from the auxiliary power source unit 400 and supplies the power to the memory disk unit 100 through the controller unit 300.
- [76] The backup storage unit 600A-B is configured as a low-speed non-volatile storage device such as a hard disk and stores data of the memory disk unit 100.
- [77] The backup control unit 700 backs up data stored in the memory disk unit 100 in the backup storage unit 600A-B by controlling the data input/output of the backup storage unit 600A-B and backs up the data stored in the memory disk unit 100 in the backup storage unit 600A-B according to an instruction from the host, or when an error occurs in the power source of the host due to a deviation of the power transmitted from the host deviates from the threshold value.
- [78] The storage device of a serial-attached small computer system interface/serial advanced technology attachment (PCI-Express) type supports a low-speed data

processing speed for a host by adjusting synchronization of a data signal transmitted/received between the host and a memory disk during data communications between the host and the memory disk through a PCI-Express interface, and simultaneously supports a high-speed data processing speed for the memory disk, thereby supporting the performance of the memory to enable high-speed data processing in an existing interface environment at the maximum.

[79] While the exemplary embodiments have been shown and described, it will be understood by those skilled in the art that various changes in form and details may be made thereto without departing from the spirit and scope of this disclosure as defined by the appended claims. In addition, many modifications can be made to adapt a particular situation or material to the teachings of this disclosure without departing from the essential scope thereof. Therefore, it is intended that this disclosure not be limited to the particular exemplary embodiments disclosed as the best mode contemplated for carrying out this disclosure, but that this disclosure will include all embodiments falling within the scope of the appended claims.

[80] The foregoing description of various aspects of the invention has been presented for purposes of illustration and description. It is not intended to be exhaustive or to limit the invention to the precise form disclosed and, obviously, many modifications and variations are possible. Such modifications and variations that may be apparent to a person skilled in the art are intended to be included within the scope of the invention as defined by the accompanying claims.

[81]

Claims

- [Claim 1] A system for backing up and restoring a semiconductor storage device (SSD), comprising:
a secondary power supply coupled to an SSD backup controller;
an alarm unit coupled to the SSD backup controller;
a backup storage device coupled to the SSD backup controller;
at least one SSD memory disk unit coupled to the SSD backup controller, wherein the alarm unit and the secondary power supply is activated in response to a deactivation of a primary power supply, wherein the backup controller backs up SSD data stored on the at least one SSD memory disk unit to the backup storage device in response to the deactivation of the primary power supply.
- [Claim 2] The system of claim 1, wherein the secondary power supply is deactivated when the backup of the SSD data is complete.
- [Claim 3] The system of claim 1, wherein the backup controller restores the SSD data to the SSD memory disk unit from the backup storage device in response to a reactivation of the primary power supply.
- [Claim 4] The system of claim 1, further comprising a main memory, wherein the backup controller further backs up main memory data from the main memory to the backup storage device in response to the deactivation of the primary power supply.
- [Claim 5] The system of claim 4, wherein the backup controller further restores the main memory data to the main memory in response to a reactivation of the primary power supply.
- [Claim 6] The system of claim 1, the at least one SSD memory disk unit comprising:
a host interface unit;
a DMA controller coupled to the host interface unit;
an ECC controller coupled to the DMA controller;
a memory controller coupled to the ECC controller; and
a memory array coupled to the memory controller, the memory array comprising at least one memory block.
- [Claim 7] The system of claim 1, the at least one SSD memory disk unit providing storage for an attached computer device.
- [Claim 8] A system for backing up and restoring a network-based semiconductor storage device (SSD), comprising:
a storage system comprising a storage system main memory, at least

one SSD memory disk unit, and an alarm unit;
a host server coupled to the storage system, the host server comprising a server main memory unit; and
a secondary power supply coupled to a backup controller and a backup storage device, wherein the alarm unit and the backup controller is activated in response to a deactivation of a primary power supply, and wherein the backup controller backs up server data from the host server main memory, storage system data from the storage system main memory, and SSD data from the at least one SSD memory disk unit to the backup storage system in response to the activation of the secondary power supply.

- [Claim 9] The system of claim 8, wherein the secondary power supply is deactivated when the backup of the server data, the storage system data, and the SSD data is complete.
- [Claim 10] The system of claim 8, wherein the backup controller restores the server data, the storage system data, and the SSD data from the backup storage device in response to a reactivation of the primary power supply.
- [Claim 11] The system of claim 8, the at least one SSD memory disk unit comprising:
a host interface unit;
a DMA controller coupled to the host interface unit;
an ECC controller coupled to the DMA controller;
a memory controller coupled to the ECC controller; and
a memory array coupled to the memory controller, the memory array comprising at least one memory block.
- [Claim 12] The system of claim 8, the at least SSD memory disk unit providing storage for an attached computer device.
- [Claim 13] The system of claim 8, the primary power supply comprising an uninterruptible power supply.
- [Claim 14] A method for backing up and restoring a semiconductor storage device (SSD), comprising:
coupling a secondary power supply and an alarm unit to an SSD backup controller;
coupling a backup storage device to the SSD backup controller;
coupling at least one SSD memory disk unit to the SSD backup controller;
activating the alarm unit and secondary power supply in response to a

deactivation of a primary power supply; and
backing up SSD data stored on the at least one SSD memory disk unit
to the backup storage device using the backup controller in response to
the deactivation of the primary power supply.

[Claim 15] The method of claim 14, further comprising deactivating the secondary
power supply when the backup of the SSD data is complete.

[Claim 16] The method of claim 14, further comprising restoring the SSD data to
the SSD memory disk unit from the backup storage device using the
backup controller in response to a reactivation of the primary power
supply.

[Claim 17] The method of claim 14, further comprising backing up main memory
data from a main memory to the backup storage device using the
backup controller in response to the deactivation of the primary power
supply.

[Claim 18] The method of claim 17, further comprising:
restoring the main memory data to the main memory using the backup
controller in response to a reactivation of the primary power supply.

[Claim 19] The method of claim 14, the at least one SSD memory disk unit
comprising:
a host interface unit;
a DMA controller coupled to the host interface unit;
an ECC controller coupled to the DMA controller;
a memory controller coupled to the ECC controller; and
a memory array coupled to the memory controller, the memory array
comprising at least one memory block.

[Claim 20] The method of claim 14, the at least one SSD memory disk unit
providing storage for an attached computer device.

[Fig. 1]

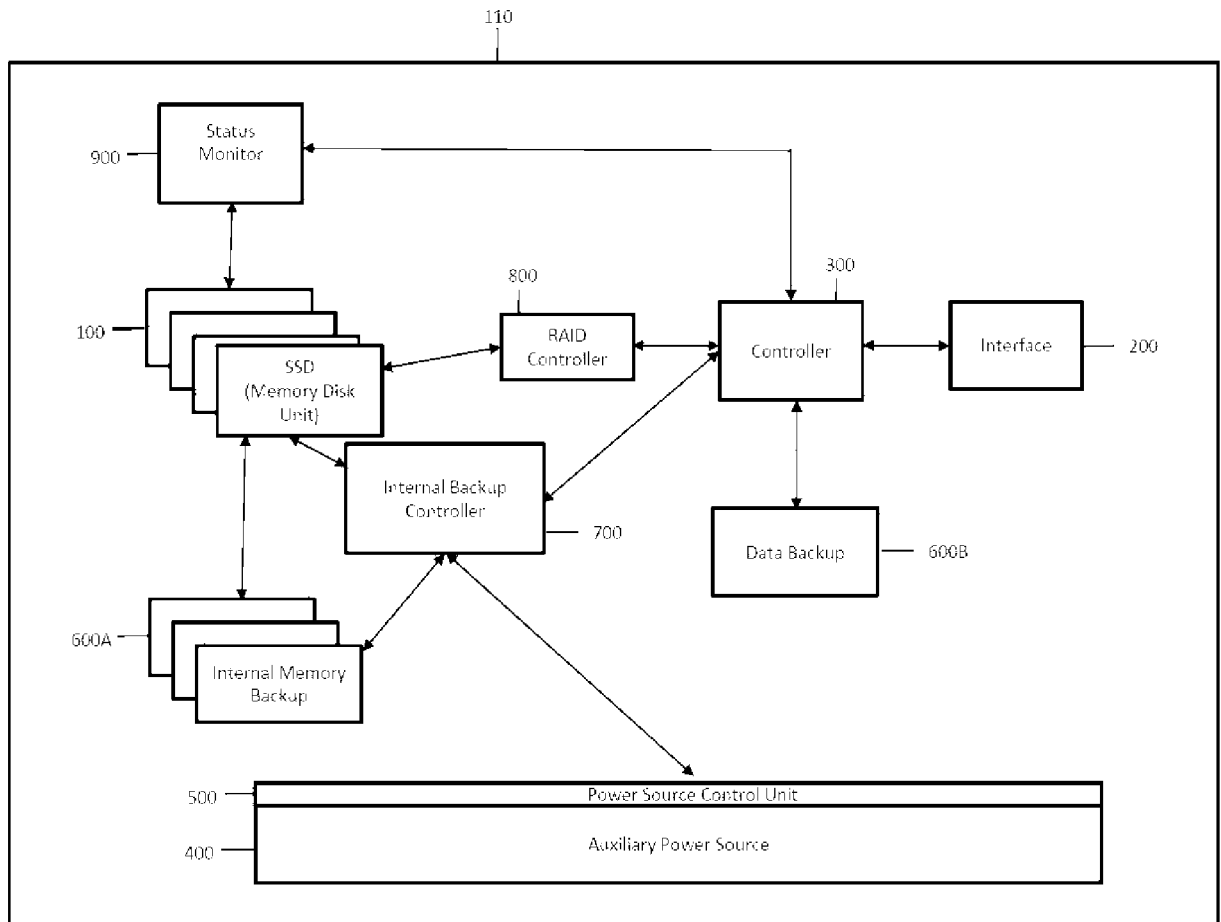

[Fig. 2]

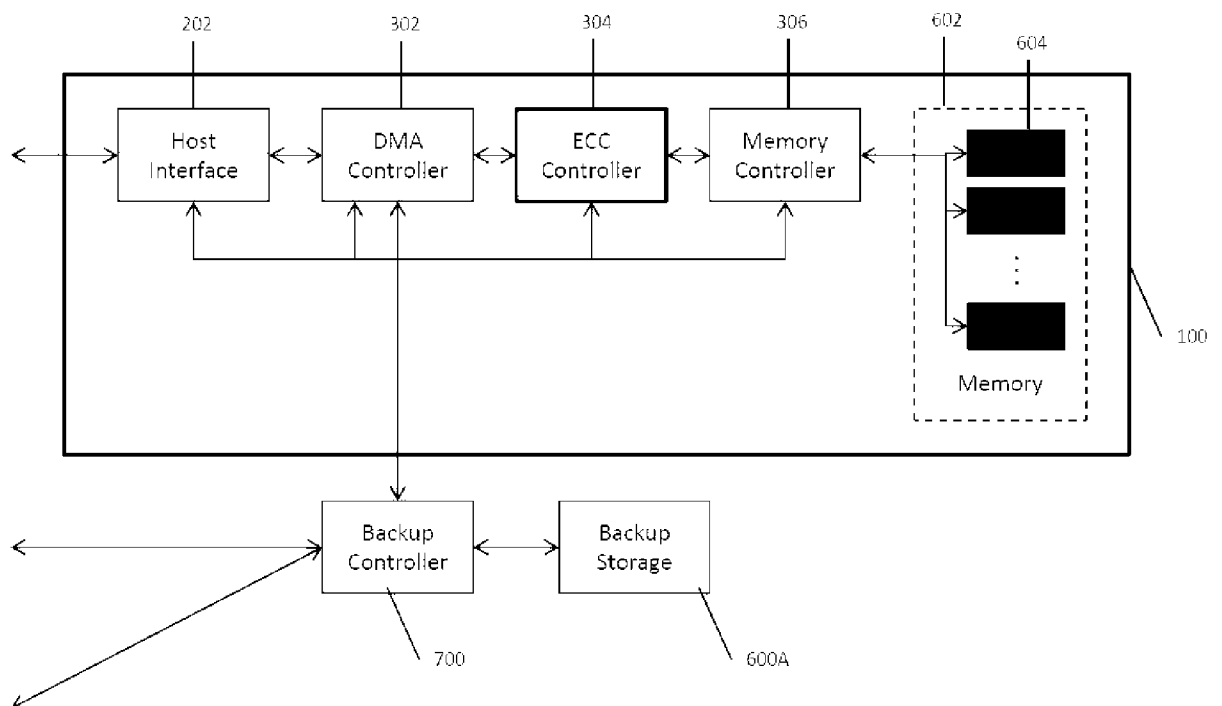

[Fig. 3]

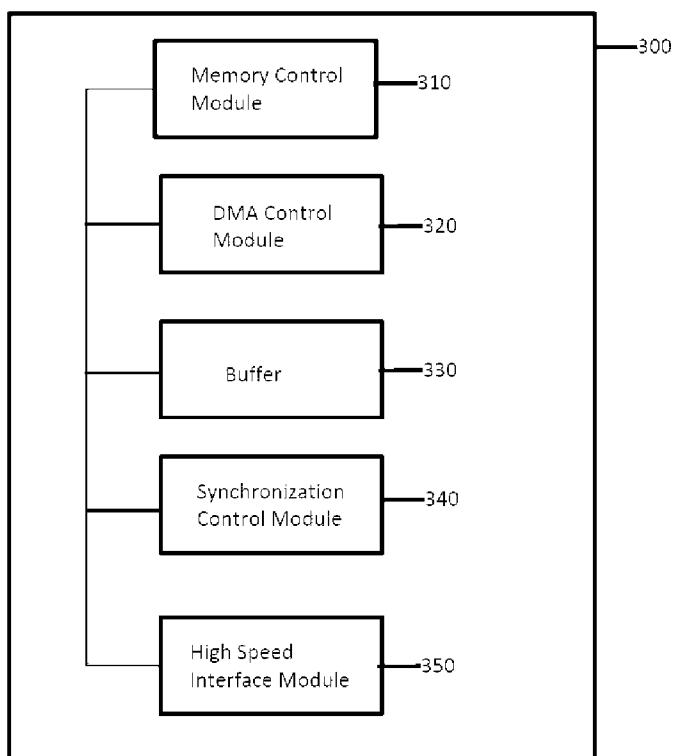

[Fig. 4]

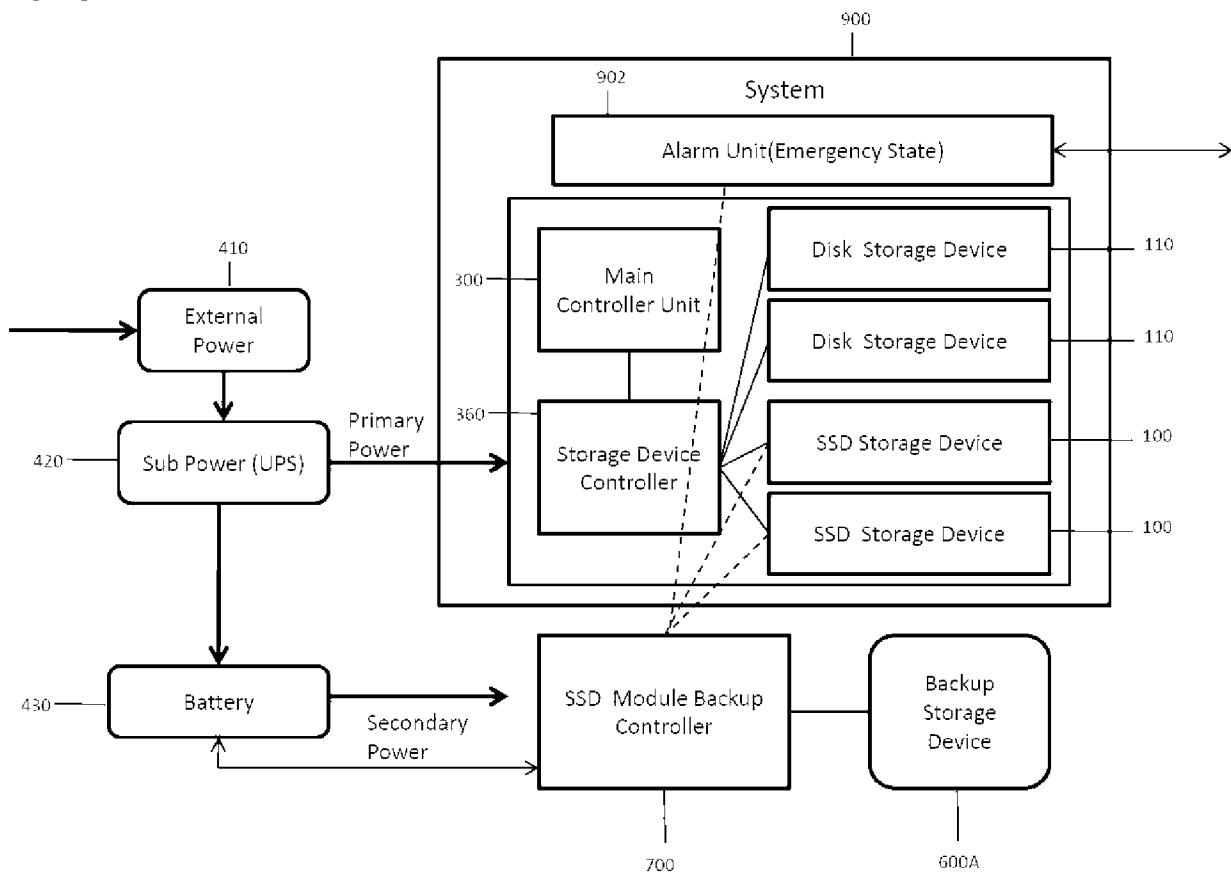

[Fig. 5]

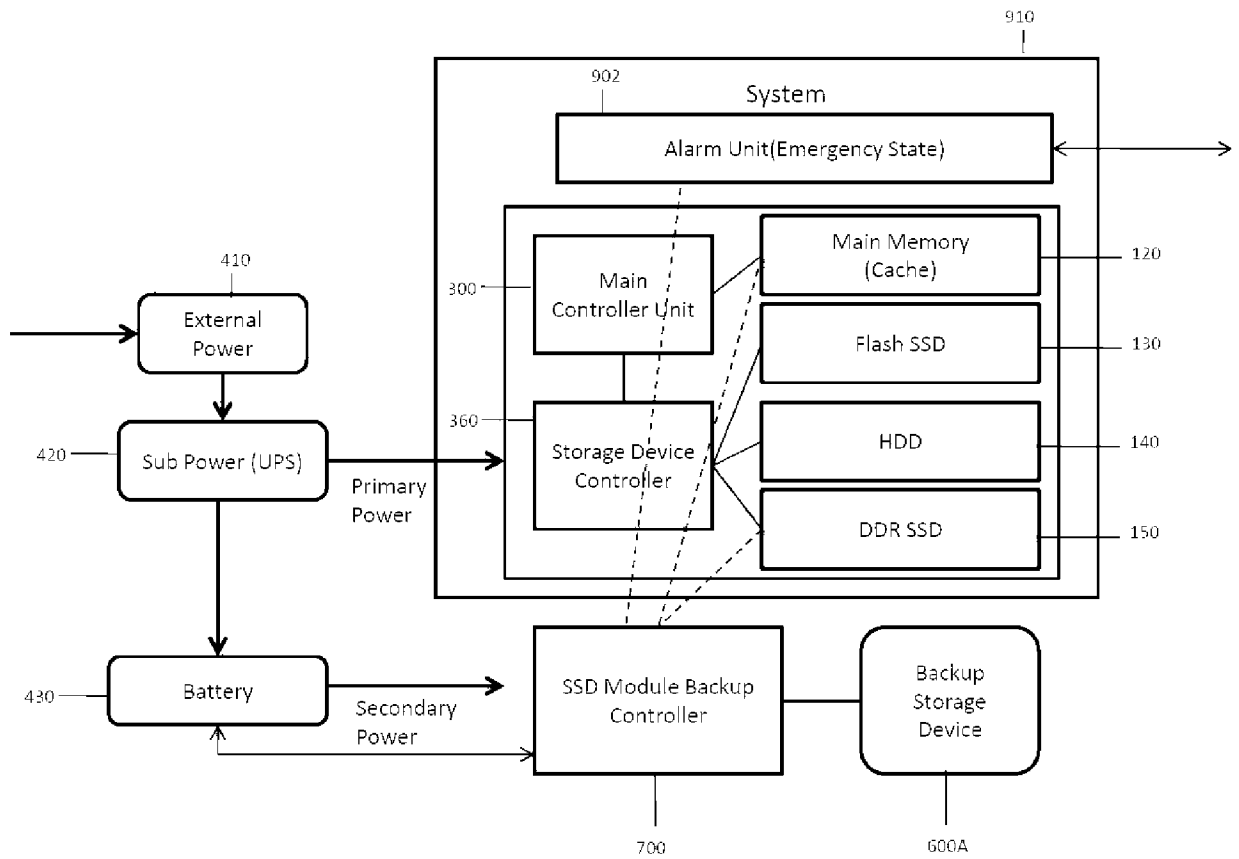

[Fig. 6]

