

J. B. PRICE.
 OIL TANK.
 APPLICATION FILED FEB. 7, 1910.

998,261.

Patented July 18, 1911.

2 SHEETS—SHEET 1.

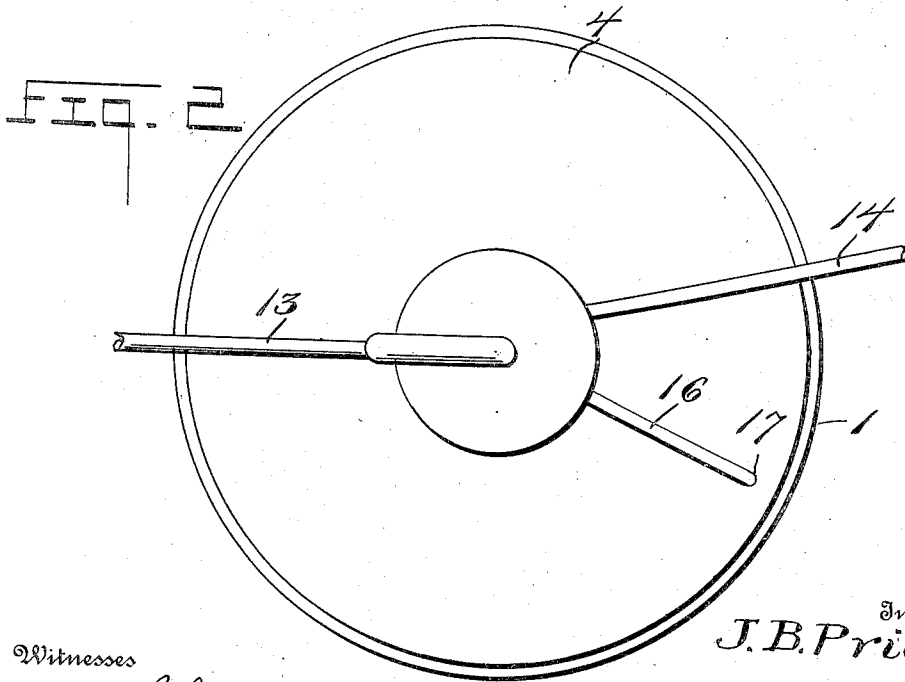
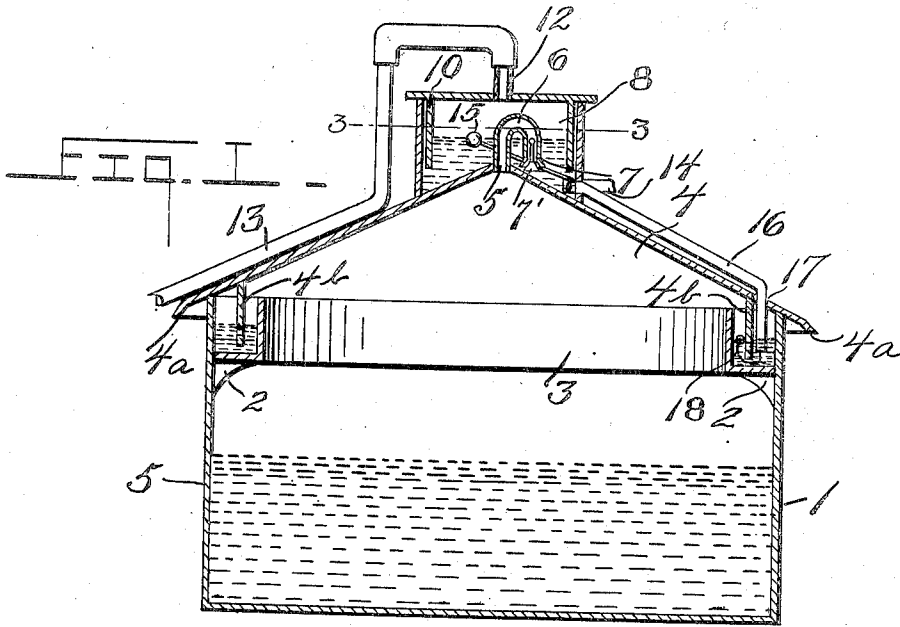

Witnesses

E. C. Johansen
E. Hurst

Inventor
J. B. Price.

By *Woodward & Chandler*
 Attorneys

J. B. PRICE.
OIL TANK.
APPLICATION FILED FEB. 7, 1910.

998,261.

Patented July 18, 1911.

2 SHEETS-SHEET 2.

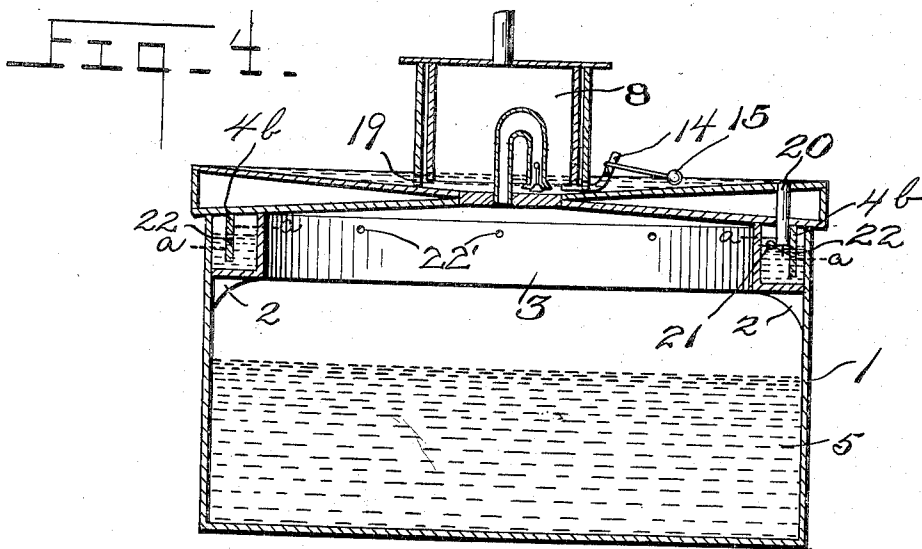
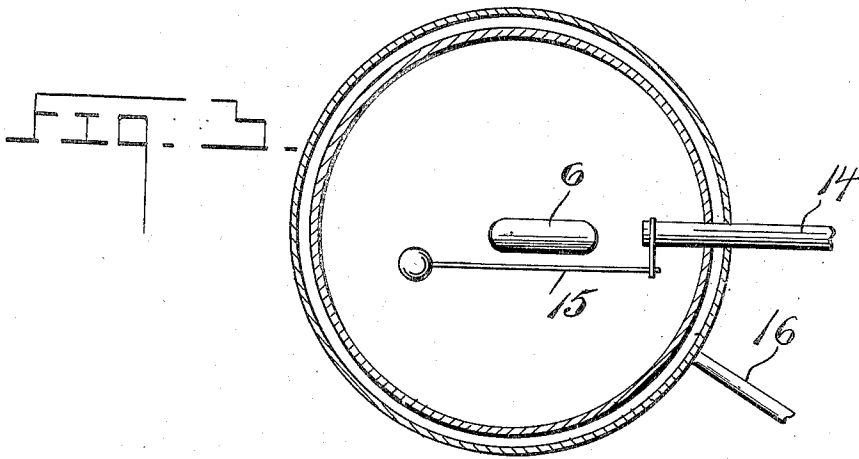

Witnesses
E. C. Johansen.
E. Hurst.

Inventor
J. B. Price.

By Woodward & Chandler.

Attorneys

UNITED STATES PATENT OFFICE.

JAMES BAIN PRICE, OF BEAUMONT, TEXAS.

OIL-TANK.

998,261.

Specification of Letters Patent. Patented July 18, 1911.

Application filed February 7, 1910. Serial No. 542,397.

To all whom it may concern:

Be it known that I, JAMES B. PRICE, a citizen of the United States, residing at Beaumont, in the county of Jefferson and State of Texas, have invented certain new and useful Improvements in Oil-Tanks, of which the following is a specification.

This invention has relation to certain new and useful improvements in oil tanks.

The object of this invention is to provide an oil tank, which will obviate the present danger due to the ignition by lightning or fire at a distance, of inflammable gases which are generated while crude oil or refined petroleum is in storage. The explosions due to such combustions are a constant menace in the oil region where conditions necessitate the storing of crude oil or refined petroleum in large quantities, and the construction of a tank which will be fire proof, and at the same time simple of construction and inexpensive, is one of the objects of my invention.

A further object of my invention is to provide an oil tank which, in case of accidental firing, will not be shattered by the force of an explosion.

Other objects and advantages will be apparent from the following description, and it will be understood that changes in the specific structure shown and described may be made within the scope of the claims without departing from the spirit of the invention.

In the drawings forming a part of this specification, and in which like numerals of reference indicate similar parts in the several views, Figure 1 is a vertical sectional view of my improved oil tank. Fig. 2 is a top plan view of same. Fig. 3 is an enlarged sectional view on the line 3—3 of Fig. 1. Fig. 4 is a vertical sectional view of a modified form of my oil tank.

Referring to the drawings 1 represents the body of a cylindrical oil tank, which should be made of sheet metal, well riveted. Near the top of the tank and mounted inwardly on the side are a plurality of brackets 2, which support an annular trough 3, adapted to contain water, which serves as a seal between the top and the body of the tank.

In the first type of oil tank contemplated

in my invention the top 4 is constructed of well riveted sheet metal or composition roofing and provided with a downwardly projecting flange 4^b, which dips into the annular trough 3. It is in the shape of a flattened cone, apex upward, the periphery of the top being provided with eaves 4^a. From the apex extends upwardly the vent pipe 5, which is curved downward as at 6, its extremity 7 being on about the same plane as the apex of the top 4 and provided with a water-check valve 7', the lower end of the pipe extending through the top. Around the pipe 5 is placed the dome 8, which serves as a reservoir for water surrounding the pipe and kept at a level below the curve 6, as shown. By this construction it will be seen that the gases which may be collected above the crude oil or petroleum are afforded a passage-way out through the pipe 5 and discharged in the water in the dome 8, thus providing an effective sealing means for preventing any combustion which may occur by burning of the gases on the outside of the tank from being communicated to the interior. It will also be seen that an effective water seal is provided between the top and the tank, the advantage of this construction being that, should the contents of the tank be accidentally ignited, such as being struck by lightning, the entire top will be raised by the force of the explosion and all danger of the tank being shattered obviated.

The dome 8 is preferably provided with a cover, having a downwardly extending flange 10, which dips into the water in the dome. A vent pipe 12 rises from the cover and may be connected to a pipe 13 for the purpose of conducting away the gases and burning them for useful purposes, or they may be discharged directly into the air.

To keep the water in the dome 8 and the annular trough 3 from being exhausted by evaporation and at an effective level I provide the following: A pipe 14 extending from the source of water supply, passes through the dome 8, and terminates beneath the level of the water. A float valve 15 is mounted near the end of the pipe 14 and connected to operate a suitable cock carried by the pipe, said float being adapted to open or close the cock according to the height

of the water in the dome actuated by the rise and fall of the water in the dome which opens and closes the valve when the float is lowered or raised thereby and it thereby governs the height of the water in the dome keeping it somewhat below the curve 6 in the pipe 5.

Mounted near the bottom of the dome 8 is the pipe 16 which extends along the top of the tank until near the edge thereof, where it curves downward and passes through the top at the point 17. The pipe 16 is arranged to discharge water from within the dome 8 into the annular trough 3, exteriorly of the flange 4^b, and said pipe is provided with a float valve 18 at its lower end, which is actuated by the water in the trough to open or close the valve through the medium of the float to retain the water in the trough 3 at a point adjacent the lower end of the pipe and thereby prevent water from flowing into the tank. By this construction it will be seen that a constant supply of water is kept in the dome and the annular trough in a manner as and for the purpose to be hereinafter more fully described.

Referring now more particularly to the modification shown in Fig. 4, it will be seen in this case that I have provided a top for my oil tank which is in the shape of two flattened cones, apex to apex, the upper one serving to contain a constant depth of water over the entire top of the oil tank, this serving as an effective lightning deflector. In this case water is supplied to the top exterior of the dome by means of holes 19 near the bottom of said dome. Water is supplied to the annular trough by a pipe 20, which opens downwardly from the top, and under the level of the water thereon, said pipe being provided at its lower extremity with the usual float valve 21.

A series of holes 22 are provided in the flange 4^b, spaced slightly from the bottom so as to be normally covered by the water. In drawing out the oil from this tank the flow of water should be first stopped and as the oil falls the annular trough is partly drained until the holes 22 are disclosed, the water being drawn upwardly and inwardly of the flange 4^b and its level outwardly thereof lowered as illustrated by the dotted lines *a, a*. The water which is admitted through the pipe leading to the trough carries a certain amount of air which fills the upper portion of the trough, so that when the water is disposed below the holes 22 in the flange 4^b, air will then escape through the holes into the tank to replace the oil or gas which has been removed therefrom and thereby prevent the water in the dome 8 from siphoning into the tank through the pipe 5. This is due to the fact that a certain amount of air will be carried into the annu-

lar trough 3 with the water, through the pipe 16 so that as the water is disposed below the holes 22 in the outer portion of the trough or below the bottom thereof, the water will escape according to the natural law of physics, into the tank portion in a manner just described, through the openings 22' in the inner wall.

What is claimed is:

1. In an oil tank, a water seal around the inner surface of the tank, a top separable therefrom and having a portion thereof dipping into the seal, a vent pipe for the top of the tank to permit the escape of gas from the tank, said pipe extending upwardly and being curved downwardly, a gas dome on said top surrounding said pipe and adapted to hold water, a cover for the dome, a gas escape therefor, said water in the dome being adapted to seal the vent pipe, a water supply pipe for the dome and a float valve connected with the pipe and adapted to keep the water in said dome above the downturned end of the vent pipe.

2. In an oil tank, a top separable therefrom, a water seal formed around the inner surface of the tank, said top dipping into said water seal, a vent pipe in said top extending upwardly and being curved downwardly, said vent pipe permitting the escape of gas from the tank, a dome on said top surrounding said pipe and adapted to hold water to seal the vent pipe, a gas pipe leading therefrom, said top being dished and means for maintaining a constant level of water to seal the vent pipe.

3. In an oil tank, a top removable therefrom and having a depending flanged portion, a trough surrounding the inner surface of the tank and adapted to hold water to form a water seal, said flange extending thereinto, a vent pipe communicating with the tank through the top and having a depending portion disposed adjacent to the top, a dome on said top adapted to hold liquid to seal the vent pipe, a removable cover for the dome, an escape pipe for gas admitted into the dome through the vent pipe, means for maintaining a constant depth of water to seal the vent pipe and an automatically operated valve in said vent pipe to prevent the escape of water into the tank.

4. In an oil tank, the combination with a receptacle having a water carrying portion therearound; of a top removable therefrom and having a depending portion disposed in said water carrying portion and below the water level thereof, said depending portion having passages therethrough disposed above its lower edge, said water carrying portion being disposed upwardly adjacent the top, a supply pipe for said water carrying portion, and depending into the water carrying por-

tion of the tank a float valve adapted to control the passage of water through said pipe aforesaid, whereby the water in the water carrying portion of the tank will be drawn
5 upwardly therein inwardly of the depending portion by the escape of gas from the tank until the level of water falls below the passages outwardly of the depending por-

tion, to allow escape of air into the tank and prevent the escape of water thereinto.

In testimony whereof I affix my signature,
10 in presence of two witnesses.

JAMES BAIN PRICE.

Witnesses:

C. M. IVES,
H. B. GRIST.