

(19)
(12)

(KR)
(A)

(51) 。 Int. Cl. ⁷
H03H 9/25

(11)
(43)

2002 - 0052958
2002 07 04

(21) 10 - 2001 - 0082648
(22) 2001 12 21

(30) JP - P - 2000 - 00395515 2000 12 26 (JP)
JP - P - 2001 - 00297021 2001 09 27 (JP)

(71) 가 가
가 2 26 10

(72) 가
가 2 26 10 가 가
가 2 26 10 가 가
가 2 26 10 가 가

(74)

:

(54)

1

1
2

1		1			
2a	2d		1		
3a	3d		1		
4a	4b		1		
5		2			
6a	6d		2		
7a	7d		2		
8a	8b		2		
9		1			
10a	10c		3		
11a	11b		3		
12a	12d		3		
13a	13c		3		
14a	14b		4		
15a	15c		4		
16a	16d		4		
17a	17c		4		
18		4			
19		3			

20 4

21 3

1

1

22

23a 23d 22

24a 24b 22

25

< >

1, 21, 41 :

2, 5, 7, 22, 25, 27 :

2a, 22a, 48a, 49a, 50a, 51a : 1

3, 4, 6, 23, 24, 26 :

5a :

7a, 27a, 48A, 49A, 50A, 51A : 2

7b, 60, 61 :

8, 27b :

9, 28, 48, 49, 50, 51 :

10, 29 :

11, 31 :

42a, 42b, 53a, 53b :

42A, 42B :

48a₁, 49a₁, 52a₁, 53a₁ :

52a, 53a :

68, 69 : 1, 2

2

. ,
 .
 1 , , 1
 1 , 1
 . , , 1 1
 , ,
 1 , 2
 1
 1 , -
 , 1 1 ,
 1
 1 1 , 2
 , 2 ,
 2 , 가 ,
 , ,
 2 , 1 1
 2 , 1
 2 , 2 ,
 , 가 ,
 2 2
 1 , 2
 1 , 1 2

(1) , 2a , (1) (2) .
 (lead titanate zirconate) , LiTaO₃, LiNbO₃ ,
 (1) LiTaO₃ .
 (2) , (2) (vapor deposition)
 (2) 5 nm 1,000 nm ,
 (2) , (2) ,
 , 1 (3)
 (2b). (3) .
 (2) (2c).
 (3) , 2d ,
 1 (2a) (1) .
 , 3a , (4) . (4)
 , (1) , (5) ((3b). , (5))
 5 nm 1,000 nm .
 , () .
 (5) , , ,
 , (4) - , 3c
 (1) (5a) .
 (6) 3d . (6) 2
 4a , (1) (7) . (7)
 , (7) , , ,
 (7) 30 nm 10,000 nm (7) 1 (2a)
 , 9 , (7) (8)
 (7) (8) . (8)
 (8)
 Ti, Ni Ni - Cr (1) 1 (2a) (7)

4b (6) 2 (7a)
 (5a) (9)가 (9)
 (7b)
 2 (7a) (7b)
 (6b)
 (9) (10) (1). 1 (11)가
 (10)
 (10)
 1 (10)
 (11)가 (10)
 가
 23 (103) 1 (103a) -
 01) (102) (101) 1 (103a) (1)
 (11) (9) 1 (2a)
 (2) (1) 1 (2a) (1)
 1 (2a) (1) (2a)
 (1) 1 (2a) (9) (1) 가
 (10) (1)
 1 (2a)
 1 22 24 1 (2a)
 (peeling rate) 가
 1

가 ,
 , 36 ° LiTaO₃ 1
 200 nm , 2
 , 10 nm Ni - Cr 840 nm .
 , 23a 23b , (103)
 가 , (101) , 1 (10)
 3a) (101) 가,

[1]

	(%)	(%)
	0	0
	0	0
-	0.5 1.0	12

1 , 0.5 1.0 % , 12 % , 가 , 0 % .

가 , (1) -
 , 가 1
 , (2) - ,
 가 ,

5 8 2 , 2 5 가 .

6a , (22) (21)
 1 (1) (2)

6b , (23) 2
 , (21) (23) 1

(22) (6c).

(23) , 6d 1 (22a)
 (22b) (21)

7a , (24) (24) 2
 (21) (25) (21)

(7c).

(24) , 2 (25a) - , 7c

7d , (26) . (26) 2

8a , (27) (21) . (27)
 1 (7) , (7) 가

8b , (26) -
 , 2 (27a) (27b) . (27b) 2 (27a)
 2 (27b)

, 1 - 2
 (27c)

(28) 2 (27a) 1 (22a)

, (29) (28) , 5 (31)가

가 (31) , 1 (22a) (21)
 , 1

, 1 (22b) 2 (25a)

, (12)

, 가

10a 10c, 11a 11b 3
 12a 12d, 13a 13c

(48a, 49a) , 1 (48a, 49a) (41) . 1

(41) , (positive) 가

, 1 (48a, 49a) 가 ,

가 , 10a 12a 1 (48a, 49a)

, (41) (negative) 가 가

, 가 가 12b ,
 (47)

(41)

(47) (42x) -
 , (42a, 42b) (52a, 53a) , 10b 12c
 (42) (42; IDT)

9a) 가 (41) (52a, 53a) (48a, 4
 (52a, 53a) (48a, 49a) 가 , 12d
 (48a, 49a) (52a, 53a)
 가 (48a₁, 49a₁, 52a₁ 53a₁)
 (48a₁, 49a₁, 52a₁ 53a₁)

49a), (47A)가 (41) (10c). 1 2 (48a,
 (52a, 53a), (42a, 42b) 가 (47A)
 (47A)가 13a

()
 (41) (48a, 49a)
 nm 1,000 nm , 300

1 2 , Ti, Ni, Ni
 -Cr

(47A)
 , 11a 13b , 2 (48A, 49A), (47A)
 1 (48a, 49a), (52a, 53a) (42a, 42b) (52A, 53A) 2 (42A, 42B)
 49A), (52A, 53A) (42A, 42B)

(48) 1 (48a) 2 (48A) , (49) 1
 (49a) 2 (49A) (60, 61)
 (48, 49) (52a, 53a) , (48, 4
 9) 2 (48A, 49A)

(64, 65) 11b 13c (48, 49)

IDT (42)가 -

49a) (64, 65) (48, 49) 1 2 , 1 (48a, 49A), 2 (48A, 49A)
(48, 49)

(60, 61) (48, 49) (52a, 53a)
1 (48a, 49a)
(52a, 53a) 가
(60, 61) (19).

21 , (60, 61)
(48) (52a)가
(52a)가 (48)
(48) (52a)가
(60, 61)

2

(48a, 49a) (48, 49) 2 (48A, 49A) 1

14a 15c 4
16a 18 4
16 18 Z 가
1 2 가 4
3 , 1 2 (41)

14a , 1 (68) 2 (69)
1 (50a, 51a) (41) 1 (68) (42
a, 42b), (52a, 53a), (42a, 42b) , 1 (48a,
49a) (42a, 42b), ,
(52a, 53a)

14a , 가 (41) 1
(68) 2 (69) 1 (50a, 51a) , 1
가 , 가

49a) (16a) 1 (68) (52a, 53a) 1 (48a, (16a)).

가 (53c, 53b), (54a, 55a) 14b 2 (69) IDT(43), 가 (47)가 16b (41) 2 (69) IDT(43) 가 (A) (4) (A) (69) IDT(43), (53c, 53b) (54a, 55a) (47) (16d).

(50a, 51a) 가 2 (69) (54a, 55a) 가 3 (17a)

1 2 (68, 69) 1 2 IDT

15a (68, 69) (71)가 (41) 1 2 (52a, 53a, 54a 55a) (42a, 42b, 53c 53b) 가 (71) (47A)가 17b (48a, 49a, 50a 51a) (B) (B) 1 (48a, 49a, 50a 51a)

가 (B) 3 가 300 nm 1,000 nm 3

(47A) (47A) 15b 17c (48A, 49A, 50A, 51A, 52A, 53A, 54A, 55A, 42A, 42B, 53C 53 B) 1 2 (68, 69) IDT (48a, 49a, 50a 51a), (52a, 53a, 53a 55a), (42a, 42b, 53c 53b)

1 (68) 2 (69) 1 (50a, 51a) 2 (50A, 51A)

(60, 61) 3

15c 18 (64 67)
(48, 49, 50 51) (68, 69) (48 51)

가 4 (60, 61) (50, 51)
(54a, 55a)
가 2 (60, 61) 1 (50a, 51a)
(60, 61) (60, 61)

55a) (60, 61) (50, 51) (54a, (68)

20 4 (48) (52a)
(48) 1 (48a) (52a)
(48) 2 (48A) (62A)
(48) (52a)가 20
(48) 1 (48a) 1 (52a)
가

4 3 (68)

(1, 21 41)

(dicing) 가

(delay line)

1 1 1 2 1
1 1 가
1 2

가 , 가 . 가 , .

2 4 1

(57)

1.

;

1 ;

1

;

2 ;

;

2.

1 , 2 .

3.

1 ,

2 ; ,

2 , 1

4.

1 ,

, ; ,

1

2

5.

1 , 1

6.

1 , 1

7.

1 , 2
1

8.

1 , - , 1

9.

1 , 2 1

10.

;

;

;

;

1 1 2 ,

1 , - ,

11.

10 , 2 ,

12.

10 ,

2 ; ,

2

,

1

13.

;

;

;

,

;

,

1

1

2

,

2

,

,

1

14.

10

,

1

15.

13

,

1

16.

;

;

;

,

;

,

1

1

2

,

2

,

,

1

17.

10 , 2 가
1

18.

13 , 2 가
1

19.

16 , 2 가
1

20.

10 , 2
, 2 .

21.

13 , 2
, 2 .

22.

16 , 2
, 2 .

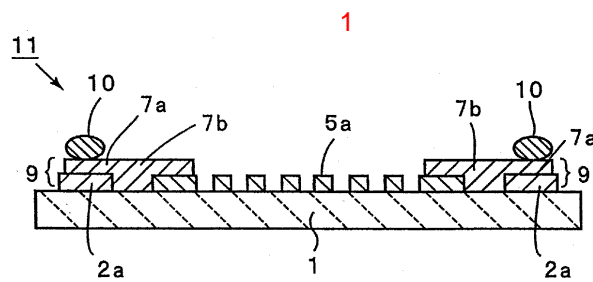

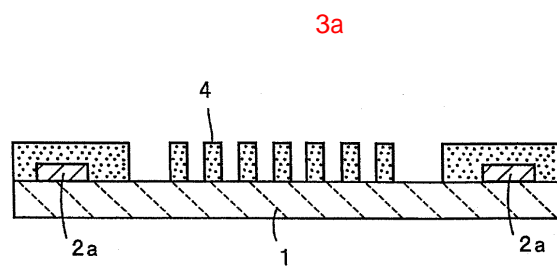
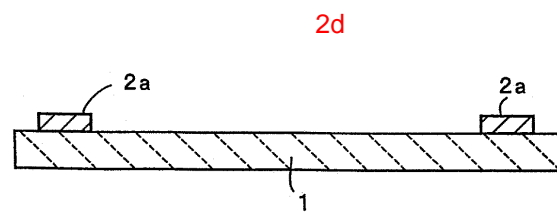
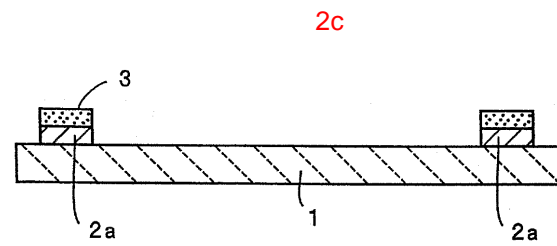
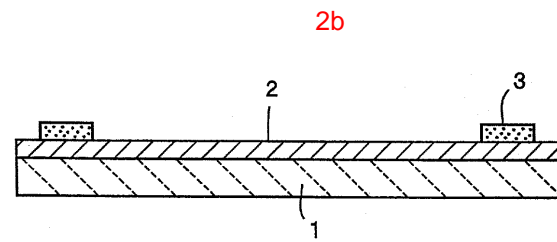
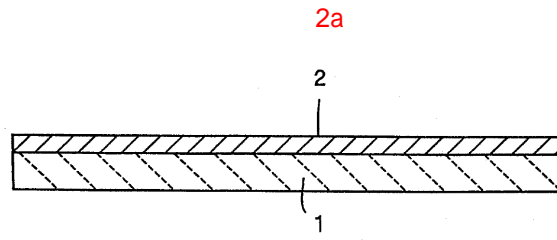

3b

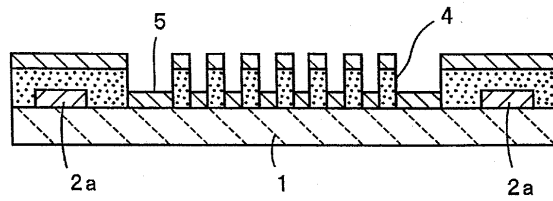

3c

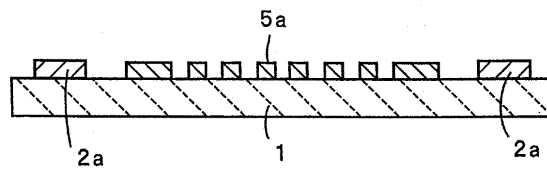

3d

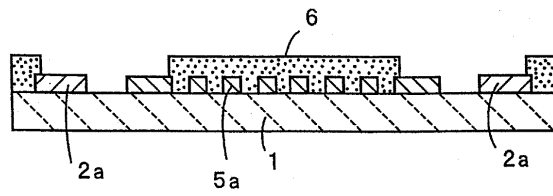

4a

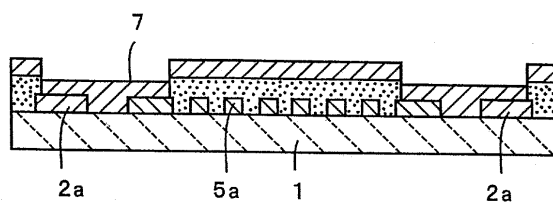

4b

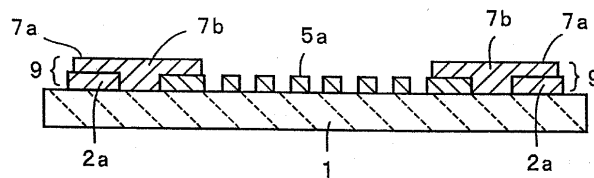

5

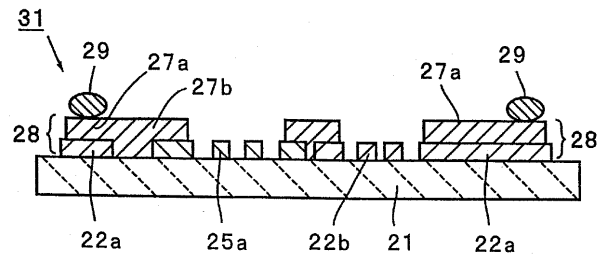

6a

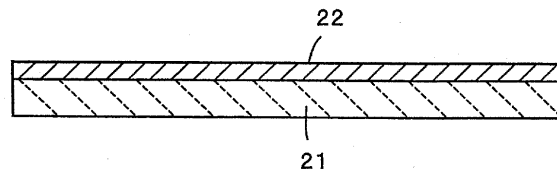

6b

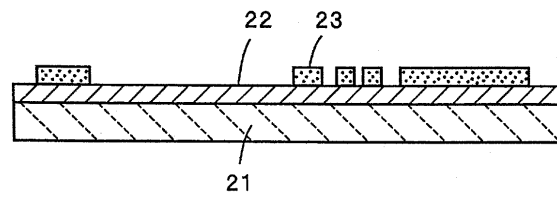

6c

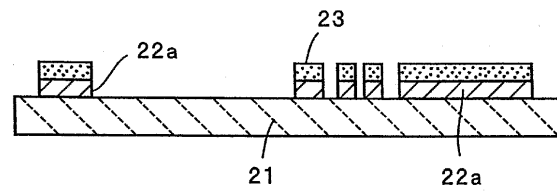

6d

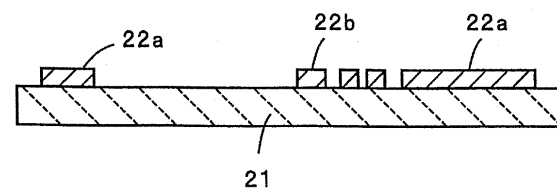

7a

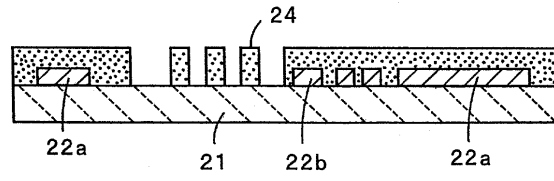

7b

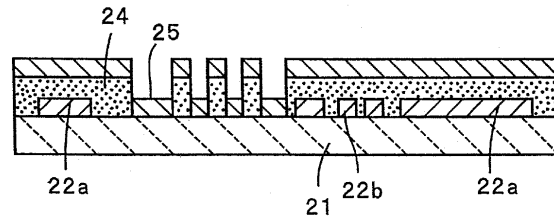

7c

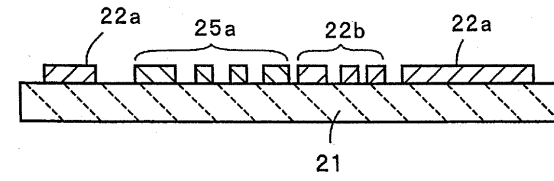

7d

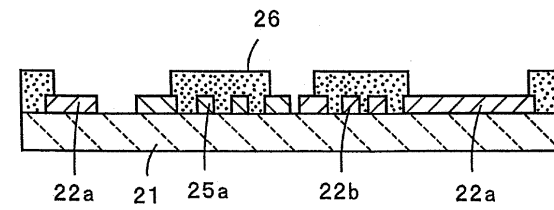

8a

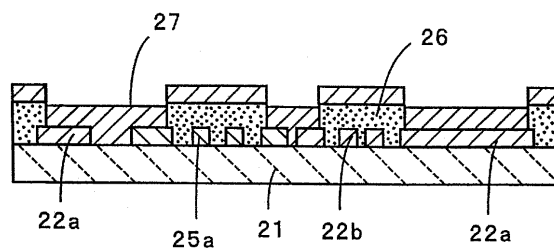

8b

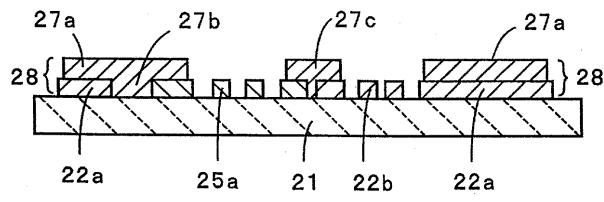

9

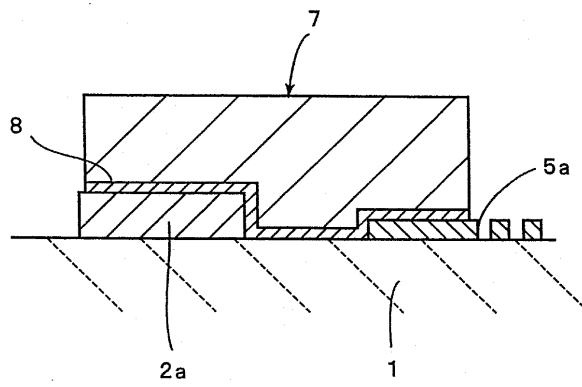

10a

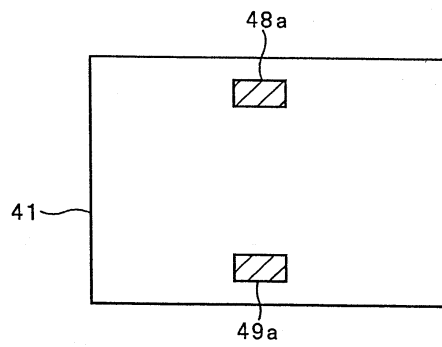

10b

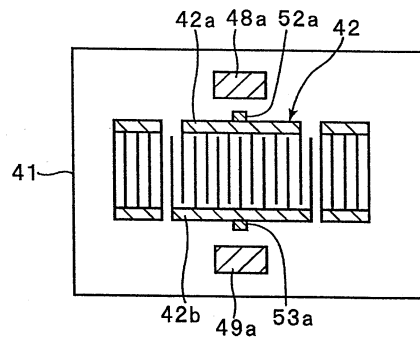

10c

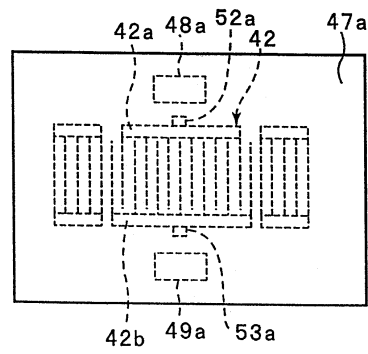

11a

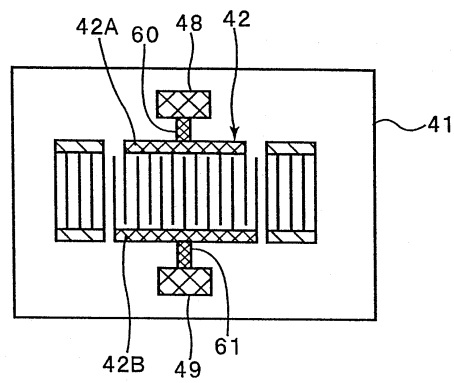

11b

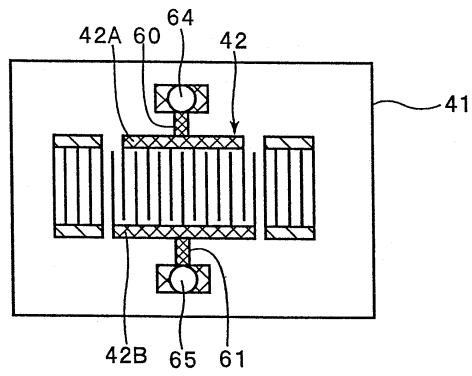

12a

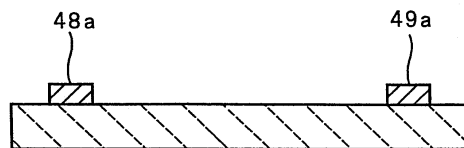

12b

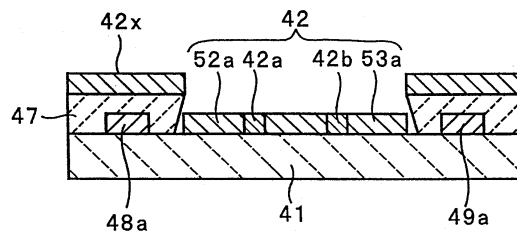

12c

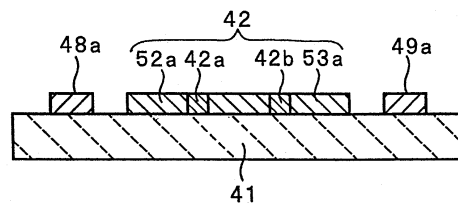

12d

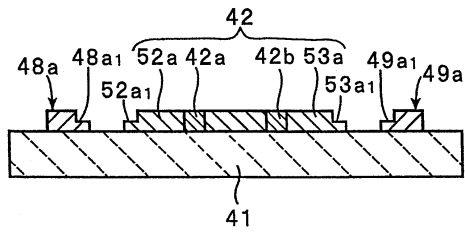

13a

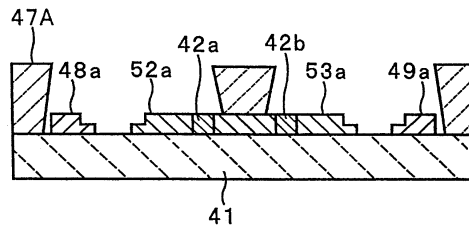

13b

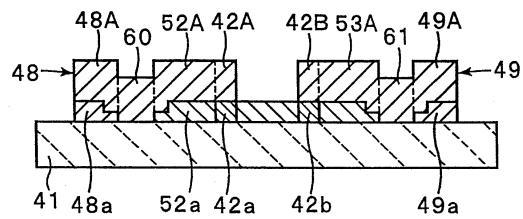

13c

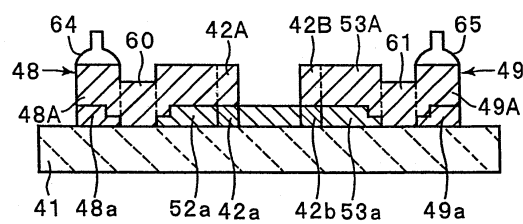

14a

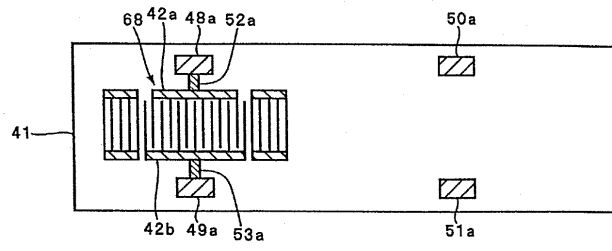

14b

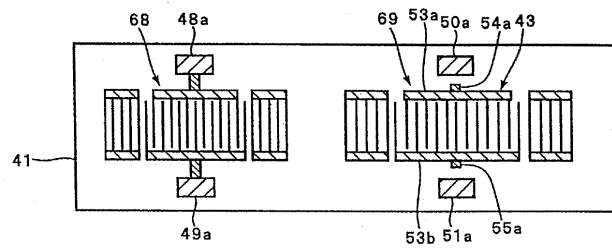

15a

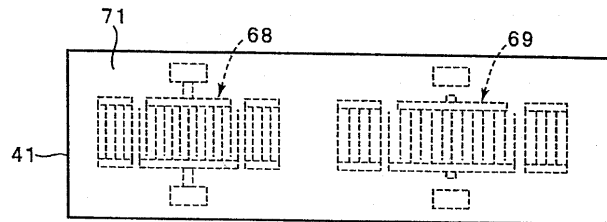

15b

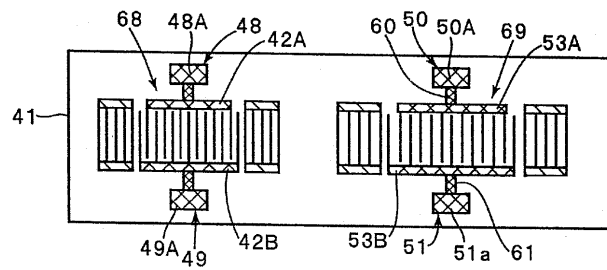

15c

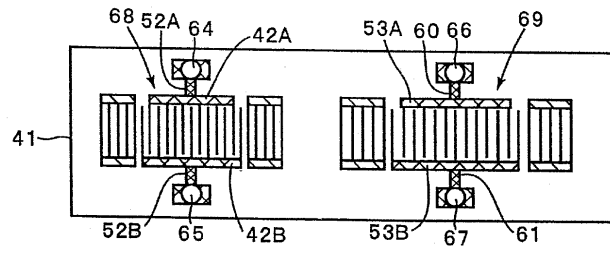

16a

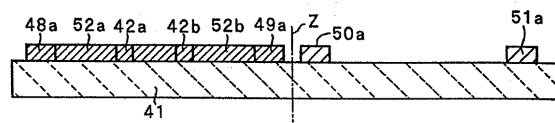

16b

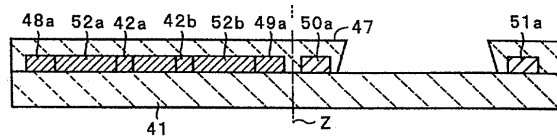

16c

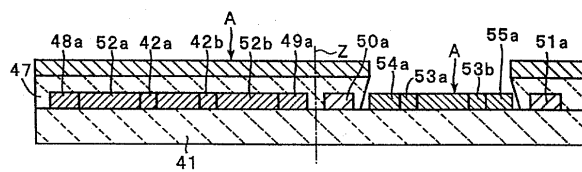

16d

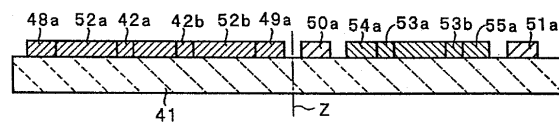

17a

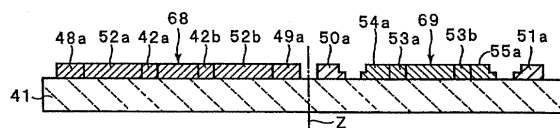

20

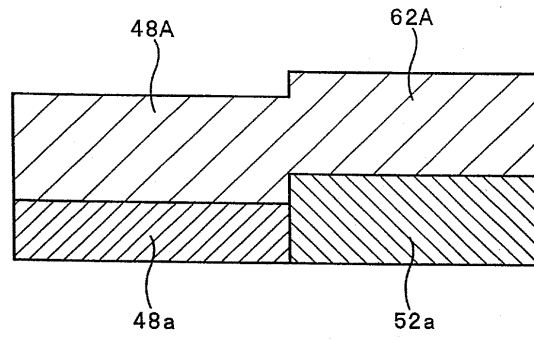

21

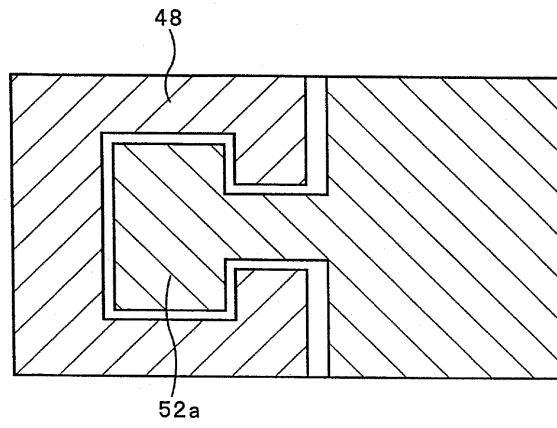

22

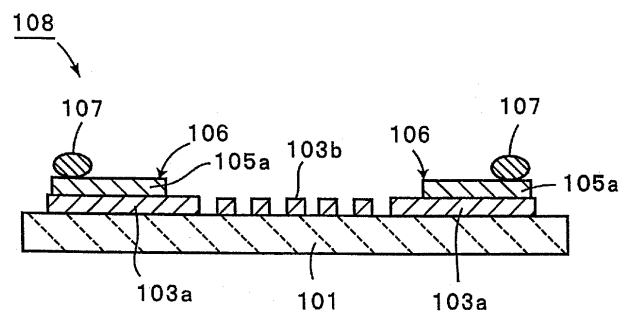

23a

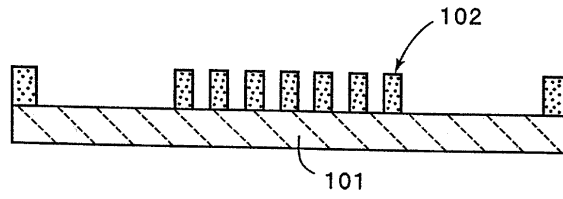

23b

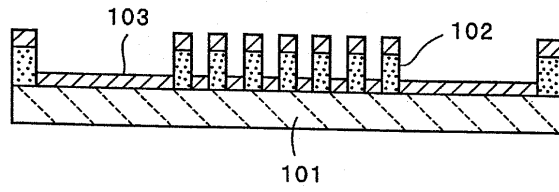

23c

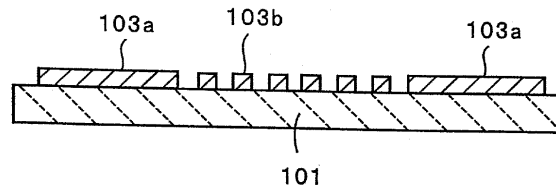

23d

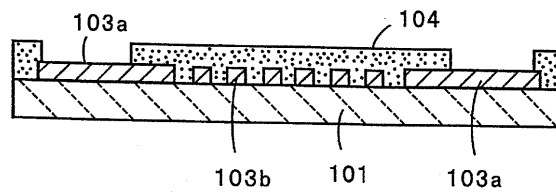

24a

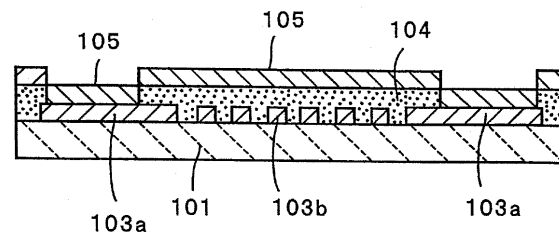

24b

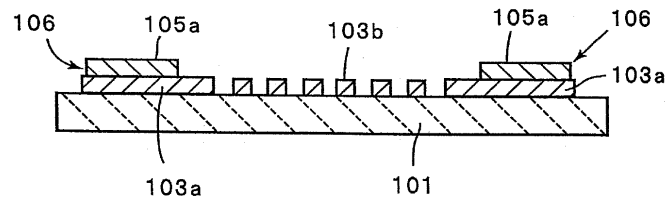

25

