

Sept. 12, 1933.

W. B. BRONANDER

1,926,192

CIGARETTE PACKAGING MACHINE

Filed June 8, 1928

8 Sheets-Sheet 1

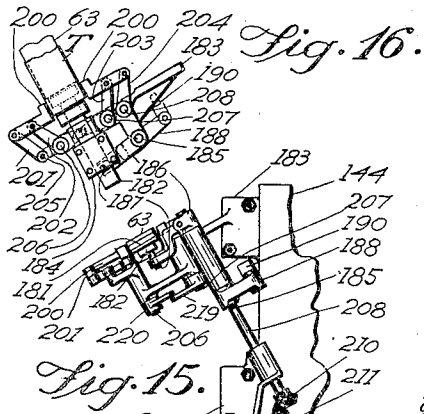

Fig. 15.

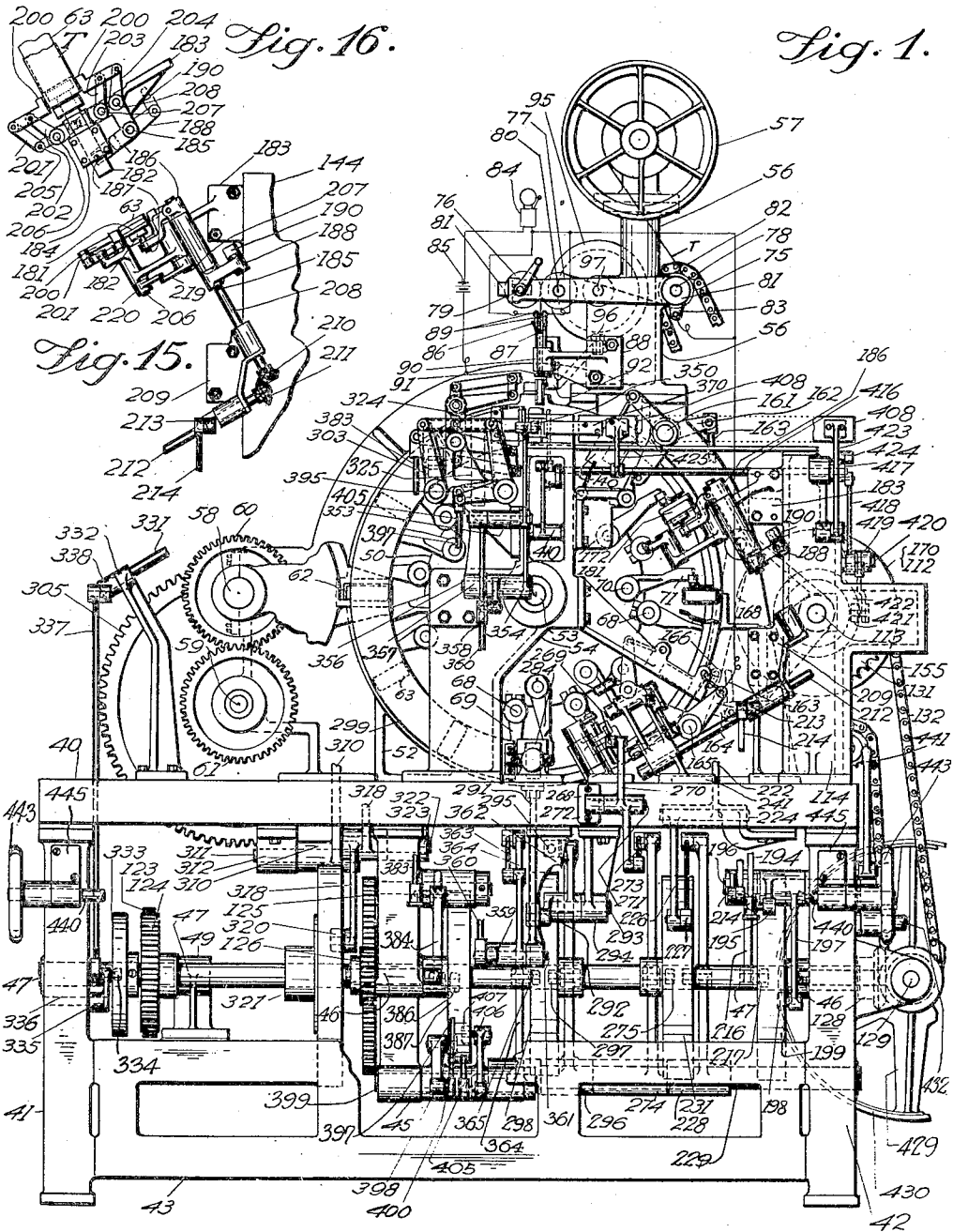

Fig. 1.

INVENTOR  
*Wilhelm B. Bronander*  
BY  
*Cydney J. Prescott*  
ATTORNEY

Sept. 12, 1933.

W. B. BRONANDER

1,926,192

CIGARETTE PACKAGING MACHINE

Filed June 8, 1928

8 Sheets-Sheet 2

Fig. 2.

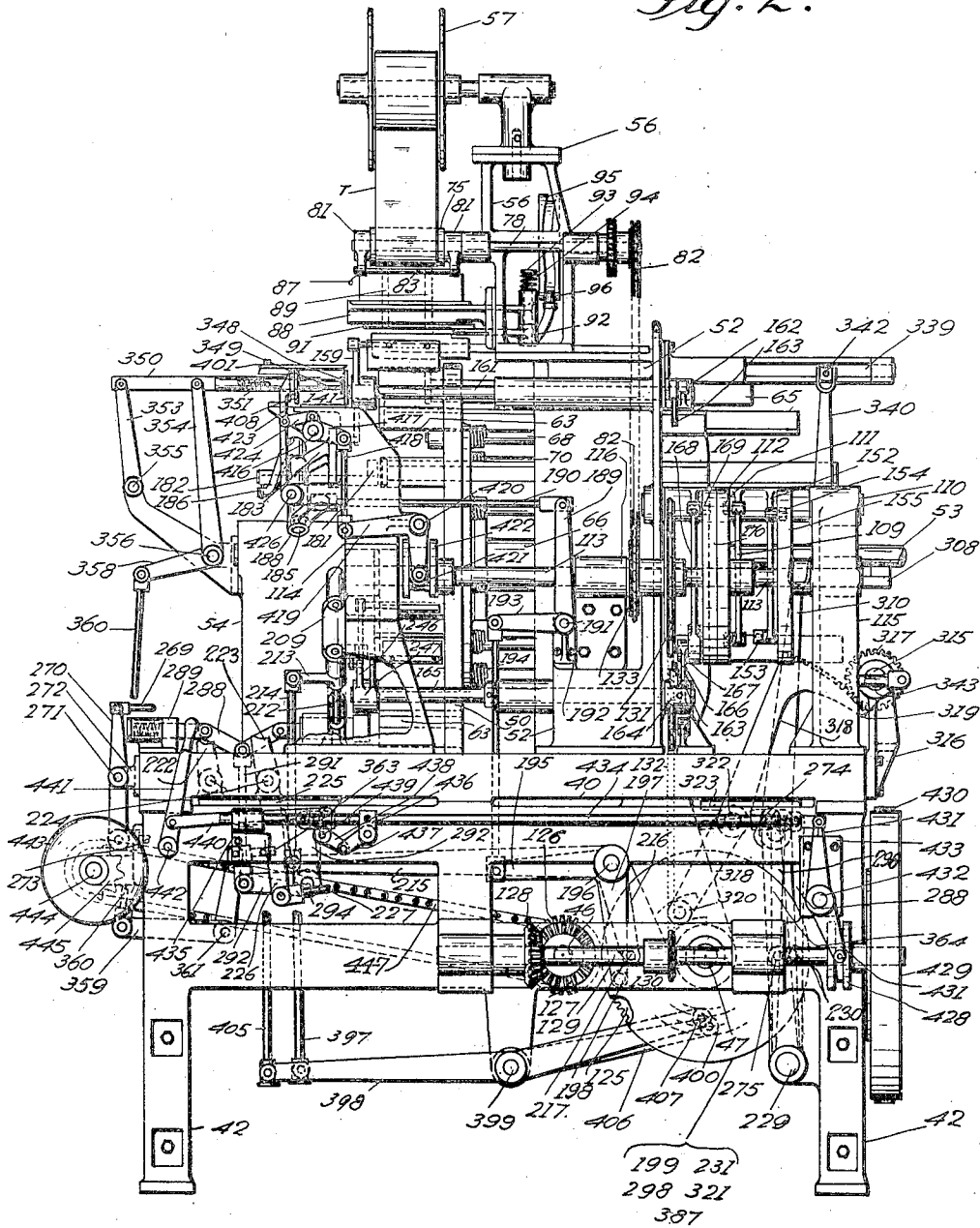

INVENTOR  
Wilhelm B. Bronander  
BY  
Sydney J. Prescott  
ATTORNEY



Sept. 12, 1933.

W. B. BRONANDER

1,926,192

CIGARETTE PACKAGING MACHINE

Filed June 8, 1928

8 Sheets-Sheet 4

Fig. 6.

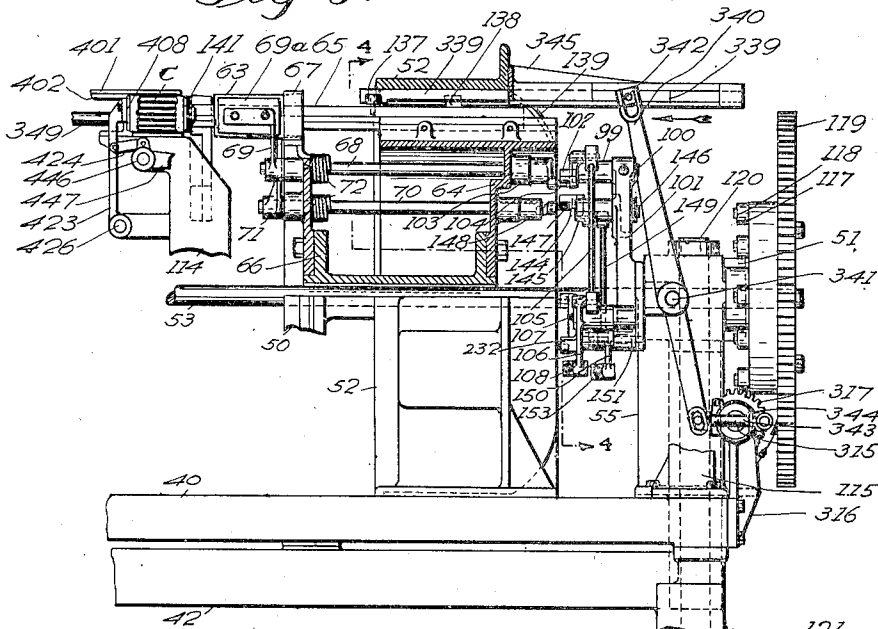
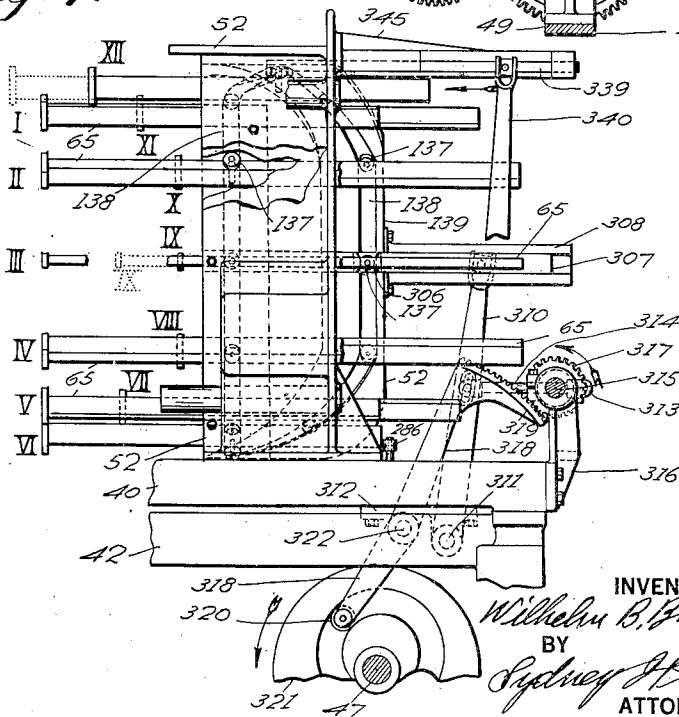

Fig. 7.



INVENTOR  
Wilhelm B. Bronander  
BY  
Sydney J. Prescott  
ATTORNEY

Sept. 12, 1933.

W. B. BRONANDER

1,926,192

CIGARETTE PACKAGING MACHINE

Filed June 8, 1928

8 Sheets-Sheet 5

Fig. 8.

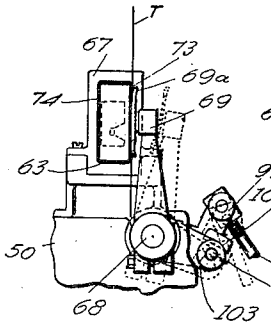

Fig. 9.

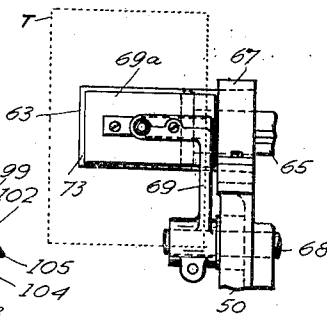

Fig. 10.

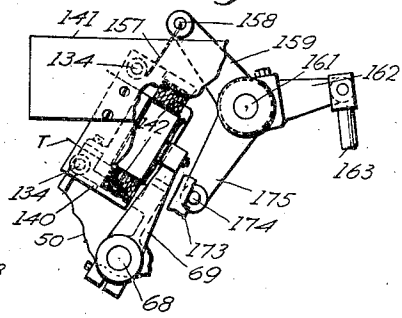

Fig. 11.

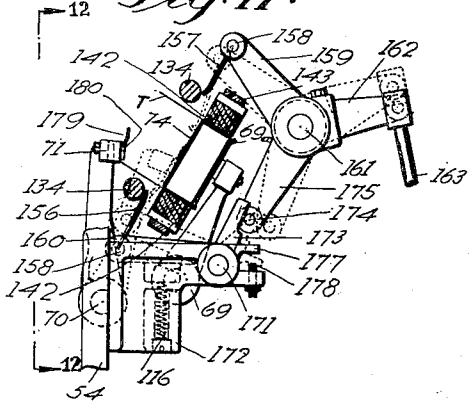

Fig. 12.

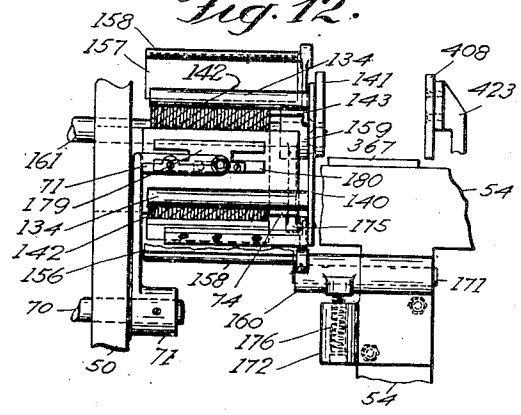

Fig. 13.

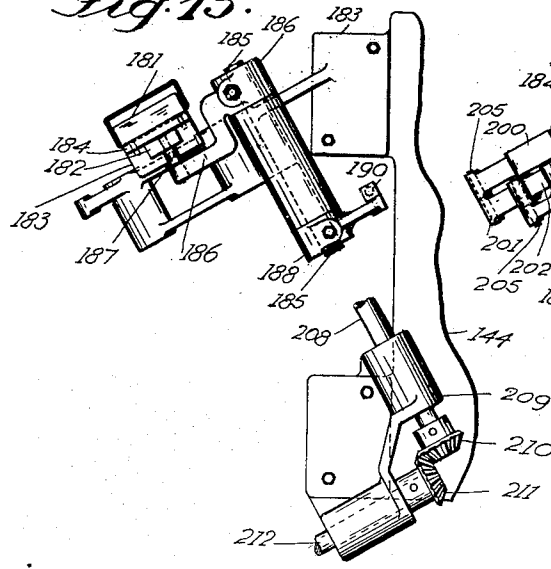
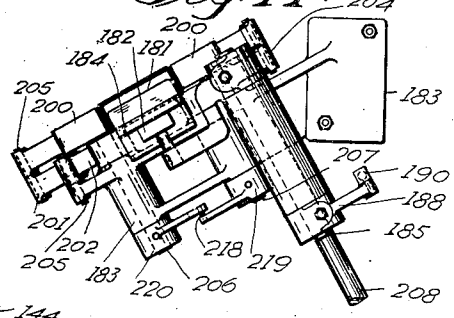

Fig. 14.



INVENTOR  
Wilhelm B. Bronander  
BY  
Sydney Alexcott  
ATTORNEY



Sept. 12, 1933.

W. B. BRONANDER

1,926,192

CIGARETTE PACKAGING MACHINE

Filed June 8, 1928

8 Sheets-Sheet 7

Fig. 23.

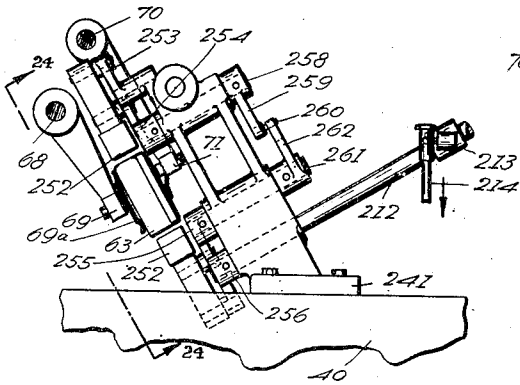

Fig. 24.

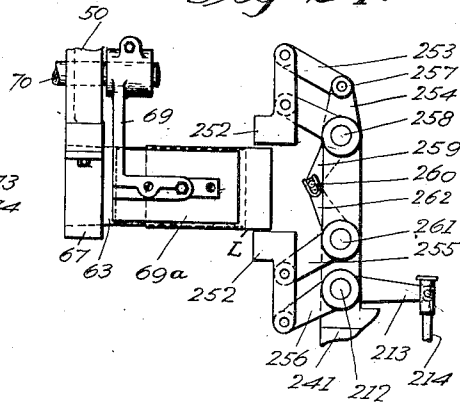

Fig. 25.

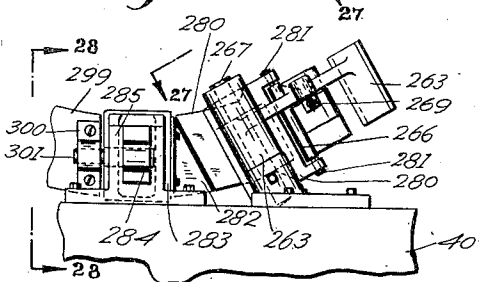

Fig. 26.

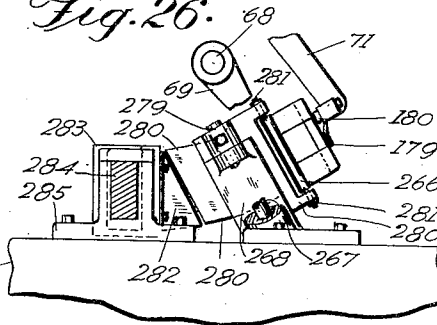

Fig. 28.

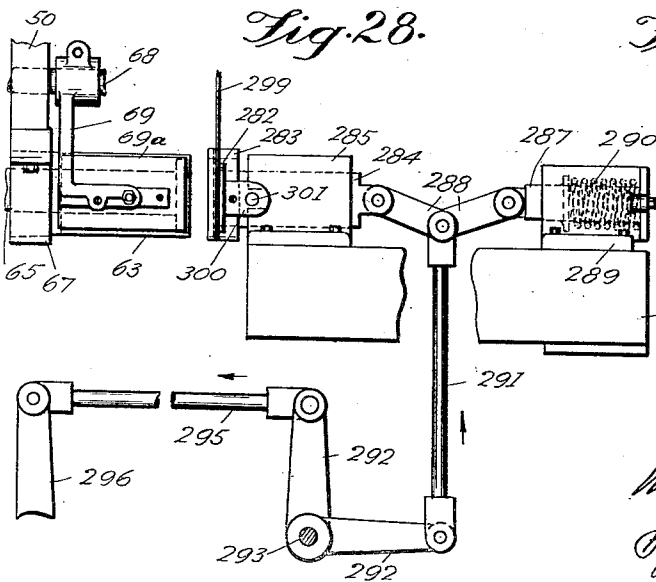
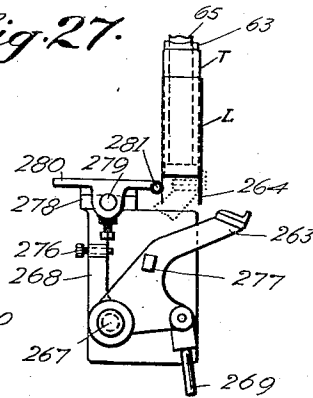

Fig. 27.



INVENTOR  
*Wilhelm B. Bronander*  
 BY  
*Sydney A. Prescott*  
 ATTORNEY

Sept. 12, 1933.

W. B. BRONANDER

1,926,192

CIGARETTE PACKAGING MACHINE

Filed June 8, 1928

8 Sheets-Sheet 8

Fig. 29.

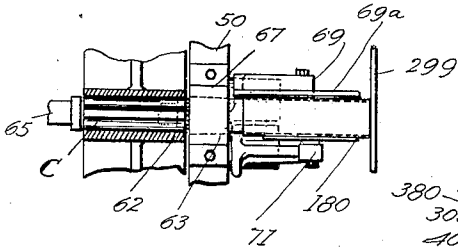

Fig. 30.

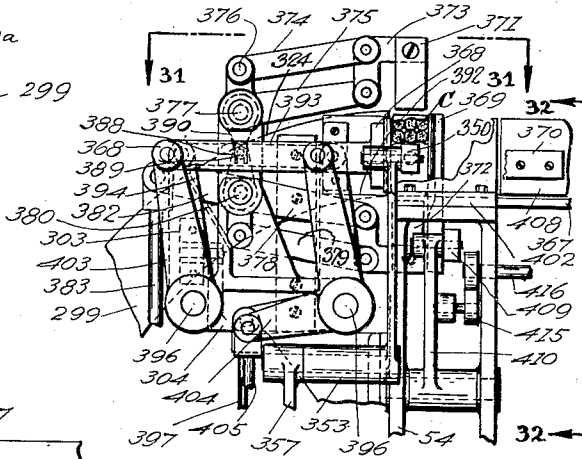

Fig. 31.

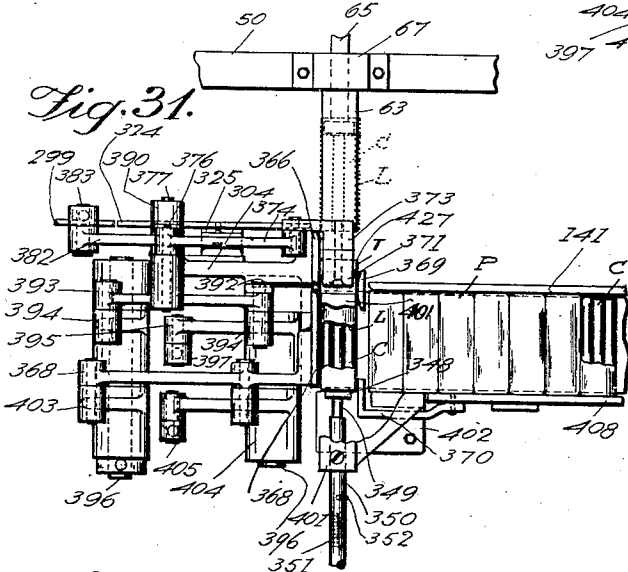

Fig. 32.

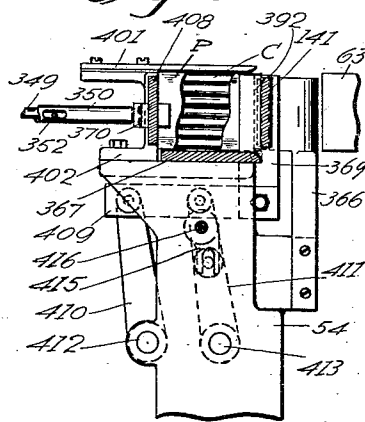

Fig. 33.

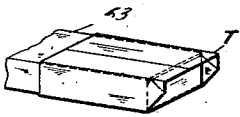

Fig. 34.

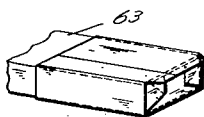

Fig. 35.

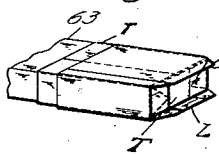

Fig. 36.

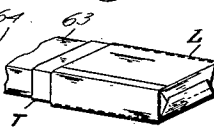

Fig. 37.

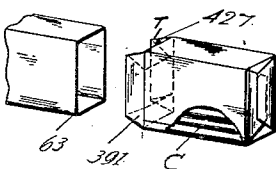
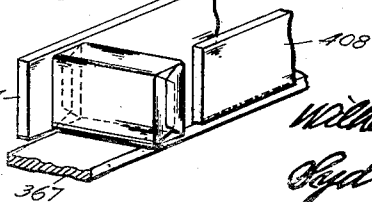

Fig. 38.



INVENTOR  
*William B. Bronander*  
 BY  
*Sydney J. Prescott*  
 ATTORNEY

# UNITED STATES PATENT OFFICE

1,926,192

## CIGARETTE PACKAGING MACHINE

Wilhelm B. Bronander, Montclair, N. J., assignor to American Machine & Foundry Company, a corporation of New Jersey

Application June 8, 1928. Serial No. 283,758

43 Claims. (Cl. 93—7)

This invention relates to cigarette packaging machines, its main object being to employ an improved method of packaging in which the cigarettes, or similar objects, may be packaged with the required rapidity, and at the same time be less subject to damage, and in which more uniform and perfect packages will be produced.

In ordinary cigarette packaging machines, the cigarettes are first grouped into package form and the covering materials are then wrapped around this group of cigarettes, thereby forming the package. In the improved machine, on the other hand, a complete empty container, including a tinfoil inner wrapper and an outer pouch with only one end open, is first formed on a package shaped support and then the cigarettes are inserted into the package so made, the open end of the tinfoil wrapper thereafter being closed. By the employment of this method of packaging, the cigarettes to be wrapped are subjected to a minimum of handling, fewer cigarettes will therefore be damaged, and the machine will produce a greater percentage of perfect packages than was heretofore possible.

Another object of the invention is to permit more rapid packaging of the cigarettes by forming the wrapper or container empty, thereby eliminating the necessity of limiting the wrapping speed to prevent injury to the cigarettes.

Another object is the production of packages of neat appearance and uniform size and shape, regardless of the firmness or shape of the group of cigarettes within the package. Moreover, since the inner wrapper and the pouch forming sheets are both circumferentially wrapped on the same firm, square cornered support, a smoothly wrapped, square cornered package with only one seam on the sides is formed.

Another object of the invention is to provide such a machine of simplified construction in which only one turret and one set of supports is needed for wrapping the container and receiving and inserting the cigarettes therein, and in which one set of plungers on the one turret contribute to form the container, insert the cigarettes and eject the container and cigarettes therein.

With these and other objects not specifically mentioned in view, the invention consists of certain constructions and combinations which will be hereinafter fully described and then specifically set forth in the appended claims.

The machine selected to illustrate this invention includes an intermittently revolving turret having a plurality of equally spaced hollow sup-

ports, or arbors, around which the tinfoil wrapper and the pouch forming sheet are folded and into which the cigarettes are inserted at different steps, or stations, during its travel; wrapper feeding and folding devices, a cigarette feeding device and package ejecting mechanism being suitably grouped around the turret.

In the operation of this machine, tinfoil for the inner wrapper is drawn off a reel and cut. After being cut, the tinfoil sheet is pressed against one side wall of the arbor and circumferentially wrapped around the arbor, and the overlapping ends are clamped against the other sidewall and the overhanging side of the tinfoil is tucked, thus forming an open container. After these operations, the outer pouch forming sheet is applied and folded around the tinfoil on the arbor in the form of a pouch. The side tucking of the tinfoil can be performed either separately or together with that of the pouch sheet, detachable means for the separate tucking of the tinfoil being provided which can be easily removed if common tucking is desired. The feeding of the pouch sheet to the under side of the arbor is accomplished by a swinging transfer arm. After the wrapper and pouch are completely folded, except that one end of the tinfoil wrapper is left open, the cigarettes, which have previously been compacted into the desired group arrangement in a suitable compressor, are fed into the hollow support, each support being provided with a plunger slidably attached to the turret and operated by a stationary cam. In the topmost position of each support, the filled pouch is ejected by the plunger, which pushes it to the entrance of a delivery chamber into which it is pushed by another plunger, after the open end of the tinfoil wrapper has been closed by a folding device.

In the accompanying drawings which form a part of this specification and in which like characters of reference indicate the same or like parts:

Fig. 1 is a front elevation of the machine with parts broken away;

Fig. 2 is a side elevation of the same;

Fig. 3 is a front elevation of the turret showing its tinfoil and pouch sheet clamping devices;

Fig. 4 is a sectional front elevation of the turret, taken on the line 4—4 of Fig. 6 and showing the operation of the tinfoil and pouch sheet clamping devices;

Fig. 5 is a fragmentary sectional view on the

line 5—5 in Fig. 4, showing the plunger cleaning brush;

Fig. 6 is a side elevation of the turret, partly in cross section, showing the operating parts of the tinfoil and pouch sheet clamping devices and of the package ejecting plunger;

Fig. 7 is a side elevation of the turret cam housing, with the turret plungers in their respective operating positions;

Fig. 8 is a front elevation of the tinfoil feeding station XII of the turret at which also the filled package is ejected;

Fig. 9 is a side elevation of the parts shown in Fig. 8;

Figs. 10 and 11 are front elevations of the tinfoil folding station I of the turret, showing the folding of the tinfoil around the arbor;

Fig. 12 is a side elevation of the parts shown in Fig. 11;

Fig. 13 is a fragmentary front elevation of tinfoil folding station II of the turret, without side tuckers, showing the folding of the lower tinfoil flap;

Fig. 14 is a fragmentary front elevation of tinfoil folding station II with side tuckers, showing the folding of the lower flap and the tucking of the side flaps;

Fig. 15 is a fragmentary front elevation showing more in detail the operating means for making the side tucks of the tinfoil shown in Fig. 1;

Fig. 16 is a top view of the parts shown in Fig. 15;

Fig. 17 is a front elevation of the pouch sheet feeding station III, showing the delivered pouch sheet held against the wall of the support;

Fig. 18 is a side elevation of Fig. 17, showing the pouch sheet in the act of being delivered by the pouch sheet transfer arm;

Fig. 19 is a front elevation of the pouch sheet folding station IV, showing the side folding of the pouch sheet;

Fig. 20 is a side elevation of the parts shown in Fig. 19;

Fig. 21 is a fragmentary front elevation, showing the top folding of the pouch sheet at station IV;

Fig. 21a is a top view from line 21a—21a of Fig. 21;

Fig. 22 is a view similar to that in Fig. 21, showing the sealing of overlapping ends of the pouch sheet;

Fig. 23 is a fragmentary front elevation, showing the side tucking of the pouch sheet at station V;

Fig. 24 is a side view on the line 24—24 of Fig. 23 showing the pouch sheet side tuckers;

Fig. 25 is a fragmentary front elevation, showing the folding of the pouch sheet side tuckers at station VI;

Fig. 26 is a fragmentary front elevation, showing the side folding roller and the sealing plunger at station VI;

Fig. 27 is a top view of the parts shown in Figs. 25 and 26, on the line 27—27 of Fig. 25, showing the folding of the pouch sheet side flaps;

Fig. 28 is a side elevation on the line 28—28 of Fig. 25, showing the sealing of the pouch sheet;

Fig. 29 is a fragmentary side elevation, showing a group of cigarettes being inserted into the support at station IX;

Fig. 30 is a front elevation, showing the folding devices for the final closing and sealing of the package at station XII;

Fig. 31 is a top view from line 31—31 of Fig. 30, showing the package ejection at station XII;

Fig. 32 is a side elevation of Fig. 31, taken on line 32—32 of Fig. 30; and

Figs. 33 to 38 are perspective views showing the successive stages of tinfoil and pouch sheet folding.

In carrying the invention into effect, there is provided a hollow support for receiving a group of articles to be packaged such, for instance, as the group of cigarettes found in cigarette packages, means for wrapping sheet material about said support to form a container, and means for subsequently inserting said group, such as a group of cigarettes, within said support and container.

In the best constructions, the wrapping means includes mechanism for wrapping an inner wrapper such, for instance, as a tinfoil wrapper, about said support, together with means for forming a pouch around said inner wrapper.

Preferably, there is also provided an intermittently rotating turret carrying said hollow support, said wrapping means including stationary folders coacting with said support. In the best constructions also, the said inserting means includes a plunger operative after insertion of the group to eject the group and the container, thus forming a package.

The means above referred to may be widely varied in construction within the scope of the claims, for the particular machine selected to illustrate the invention is but one of many possible embodiments of the same.

The invention, therefore, is not to be restricted to the precise details of the structure shown and described.

Referring to Figs. 1, 2 and 3, of the accompanying drawings, which form a part of this specification and in which like characters of reference indicate the same or like parts, the working parts of the machine are shown mounted on the table 40 which rests on pedestals 41 and 42 connected by frames 43 and 44. The pedestal 42, together with a bracket 45 attached to the under side of the table 40, carry the main drive shaft 46, and the pedestals 41 and 42, together with the bracket 45, support a cam shaft 47.

To receive and suitably support the package forming elements and to carry them step by step to the several stations where these package forming elements are received and the package forming operations are performed, there is provided an intermittently rotated turret. This turret is operated by a shaft 48 in brackets 49 carried by the frame 44, which intermittently rotates the turret 50 by means of an indexing device of well known construction, to which further reference will be made hereinafter. This turret 50 is located in a cylindrical housing 52 mounted on the table 40. The turret revolves with its rear portion within this housing on a shaft 53 supported in stands 54 and 55, also mounted on the table 40. On top of the housing 52 is attached a bracket 56 carrying the tinfoil reel 57. In a lateral extension of housing 52 are supported shafts 58 and 59, the latter of which is directly geared to the turret and drives the shaft 58 through the spur gears 60 and 61, thus driving a compacting device mounted on shaft 58 having compacting pockets 62. From these pockets, as will be presently described, the package size groups of cigarettes are delivered into the hollow supports 63 on the turret.

The turret itself (Figs. 4 and 6) consists of three parts, the front part 50 of which is disc

shaped and on which are located the package supports 63. Connected to this front part by a hub 66 is a flanged rear part 64 encircled by the housing 52 and carrying the plungers 65.

5 The hollow supports 63 which support the package forming elements on the turret and also serve to support the said elements against the action of the wrapping and folding devices, are of the same shape and size as the package to be  
10 formed. There supports are made of thin sheet metal and are box shaped, with open ends to permit insertion of a group of cigarettes, or other articles, in one end and to permit ejection of said group out of the other end. These supports, which are equally spaced around the turret, are held by blocks 67 attached to the disc shaped portion of the turret.

15 The clamps 69 and 71 are provided cooperating with the supports to clamp the tinfoil and pouch forming sheets against the walls thereof at proper times during the container forming operations. Clamp 69 is carried by the shaft 68 and clamp 71 is held by a shaft 70, these shafts being located in bearings provided on the turret parts 50 and 64. Springs 72 fastened to these shafts and to the turret 50 normally press clamps 69 and 71 against the opposite side walls 73 and 74 of the supports 63. It is noted that each support has its own pair of clamps, together with the above described clamp supporting means.

20 For the purpose of placing the inner tinfoil wrapper sheet on the support, tinfoil T from the reel 57 is passed over the roller 75 and is pulled off the reel by rollers 76 and 77. These rollers 76 and 77 are driven by any suitable means from the shaft 78. Roller 75 is loosely mounted on shaft 78 and the rollers 76 and 77 are fixedly  
25 mounted on shafts 79 and 80, supported in an arm 81. The details of the construction of this tinfoil feed are not a part of the present invention and reference is made to my Patent No. 1,608,163, issued November 23, 1926, for a full disclosure of a similar tinfoil feed.

30 On the arm 81 there is mounted an insulated rod 83, which is connected with the metal frame of the machine through an electrical bell 84 and a battery 85. If the tinfoil, which is in contact with the metal part of the machine, should tear and thereby touch the rod 83, it will complete the circuit through the bell 84 and give an alarm. The tinfoil fed by the rollers 76 and 77 is guided between the side 73 of the support and the clamp 69 by two guide plates 86 and 87  
35 mounted on an arm 88 attached to the bracket 56. Two pairs of insulated strips 89 are attached to the guide plates 86 and 87, these strips also being connected to the bell 84. The tinfoil, if it tears or becomes too slack, makes contact with the insulated strips 89 and causes the bell 84 to ring.

40 When the desired length of tinfoil has been fed, it is cut by the knife bars 90 and 91, the former being fixedly mounted on the arm 88, while the latter is pivoted on an arm 92 held by a stud 93 located in an extended bearing of the arm 88. A spring 94 is provided to bring the cutting edges of the knife bars 90 and 91 into contact. A cam 95, in which a roller 96 mounted on the arm 92 is guided, is mounted on shaft 97 which shaft is suitably driven from shaft 78 and imparts reciprocating motion to bar 91. The tinfoil sheet, having entered between the clamp 69 and the side of the support 63 with the mid-portion of the sheet near the middle of said

side, the clamp 69 is actuated to close against the wall 73 and thus hold the sheet in proper relation to the support during the subsequent wrapping operations. This clamp is held open by a lever 99 which is loosely mounted on a stud 100 held in bracket 101 fixed to the stand 55, and as shown in Figs. 4 and 6, this lever has a projecting lug 102. Levers 103 are mounted on the shafts 68 carrying the clamps 69, having pins 104 which engage with the lug 102 when in actuating position, and thus open the clamps 69.

The lever 99 is connected by a rod 105 with a lever 106 swinging on a stud 107 and also located in the bracket 101. A rod 108 connects the lever 106 with a bell crank lever 109 swinging on a shaft 110, and having a cam roller 111 in engagement with a cam 112 on shaft 113 located in stands 114 and 115 and in a bracket 116, the first two of which are attached to the table 40, and the last of which is affixed to the housing 52.

Thus, at the proper time, rotation of cam 112 sets the lug 102 on lever 99 in position to permit closing of the clamp 69 by the spring 72, thereby causing the clamp plate 69a to press the tinfoil against support wall 73 and while so held, the tinfoil is cut, the turret thereupon leaving the tinfoil feeding station and advancing to its next station.

The proper timing of the step by step, or intermittent movement of the turret is accomplished by any suitable indexing device, such as that shown generally at 51, which operates on rollers 117 held by studs 118 mounted on the spur gear 119, so that the turret moves the annular distance between the axes of the adjacent rollers at each step. The details of the indexing device are not a part of the present invention and reference is made to the above mentioned Patent No. 1,608,163 for a detailed disclosure of a suitable indexing device for this purpose. The indexing device is keyed to a shaft 120 located in the stand 55 and is driven by a bevel gear 121 which meshes with another bevel gear 122 on the shaft 48. The shaft 48 is driven by a spur 123 meshing with a gear 124 on the shaft 47. This shaft, in turn, is driven by spur gear 125 meshing with a spur gear 126 on shaft 46, which has bevel gear 127 in mesh with the bevel gear 128 on the drive shaft 129. The sprocket 130 on the shaft 129 connected to a sprocket 131 by a chain 132, drives the cam shaft 113. A sprocket 133 on this cam shaft operates the tinfoil feed by means of a chain 82.

For convenience in describing the operation of the machine, the various stations at which the given support 63 stops in the intermittent rotation of the turret, are designated by the roman numerals I to XII, as shown in Fig. 3, these stations corresponding in position to the same numerals on the dial of a clock.

Means are provided for circumferentially wrapping the tinfoil about the support 63 as this support moves from the tinfoil feeding station XII to station I. These means include two stationary rods 134 (Figs. 10, 11 and 12) located on opposite sides of the path of the support and between which the support passes in its movement to the station I, thereby bending up the overhanging flaps of the tinfoil sheet clamped on the support. These rods 134 are held by a plate 140, which is attached to the sidewall 141 of a package delivery guideway at station XII to be hereinafter described.

During this movement of the support from

station XII to station I the plunger 65, which at station XII is within the hollow support 63, is forced to move outwards and at station I comes into alignment with the front end of said support covering the entrance of the same and providing a flat supporting surface across said end during the subsequent wrapping operation. Without this supporting surface, the folding of the ends would be somewhat difficult, since there would be nothing to support the end against the means which fold and seal that end.

The turret plungers 65 are slidably mounted on the rear part 64 of the turret and have on the front part 50 fixed and adjustable guides 135 and 136 respectively, one of these plungers being provided for each of the supports 63. These plungers are actuated by a cam roller 137 mounted on the top of each plunger, the cam rollers being guided in a track 138 in a stationary cam 139 attached to the inside of the cylindrical housing 52 which surrounds the rear portion of the turret (Fig. 7). From station I to station VI the front entrance (as viewed in Fig. 1) of each hollow support 63 is closed by the flat end of a plunger 65, as above mentioned.

The overhanging flaps of the tinfoil, after being bent up by the rods 134, are brushed over the narrow sides of the arbor pocket and held in position thereon by the stationary brushes 142 held by angle pieces 143 fastened to plate 140. To allow the folding of the bent up flaps, the seam clamps 71 (Figs. 4 and 6), are opened against the tension of one of the springs 72 by means of a projecting lug 144 of lever 145 which swings on stud 146 in the bracket 101, the lug while being forced downwards engaging with pins 147 of levers 148 on the shafts 70. The downward movement of the lever 145 is caused by the link 149 attached to said lever and to a bell crank lever 150 swinging on a stud 151 and rocked by a cam lever 152 connected to it by a rod 153. The cam lever 152 swings on the shaft 110 and has a roller 154 in engagement with the cam 155.

The bent up tinfoil flaps are folded over by two resilient folding plates 156 and 157 (Figs. 11 and 12). These plates, which enter the space between the stationary rods 134 and the side wall 74 of the support, are held by rods 158 pivoted to oscillating bell cranks 159 and 160. The former is fixedly mounted on a shaft 161 which is located in the housing 52. An arm 162 clamped to the shaft 161 is connected by a rod 163 with one arm of a forked or two-armed lever 164 fixed on shaft 165. The other arm 166 of the forked lever is provided with a pin 167 engaging in a slot in a rock lever 168 which is oscillated by a cam bowl 169 in engagement with a cam 170. Thus, oscillation of the lever 168 oscillates the lever 164, the shaft 165, and through rod 163 oscillates the bell crank 159. A spring 176 held in a bracket 172 pushes against the under side of the bell crank lever 160 thereby establishing contact between an arm 173 of the bell crank lever and the pin 174. As soon as the arm of the bell crank 159 which carries the plate 157, moves downward to fold the flap over the support side wall 74, the arm of bell crank 160, with plate 156, moves upwards due to the action of the spring 176. The side folding effected by the plate 156 takes place before that of the plate 157, because the former plate is nearer to the tinfoil than the latter, the latter fold therefore being smoothly

laid over the former. A projecting lug 177 on the bell crank lever 160, by hitting against a stop screw 178, limits the upward motion of the folding plate 156.

After the tinfoil flaps are folded over, and while still held against the sidewall 74 by the folding plates 156 and 157, the seam clamp 71, which was held open by the lug 144 of lever 145, is again closed by operation of lever 145 to release the lug 144 from engagement with pin 147 of lever 148 on the shaft 70. When the clamp moves towards the arbor, springplate 179 reaches the tinfoil first and smooths it out while strip 180 holds the seam, the folding plates 156 and 157 now moving back to their normal positions (Figs. 11 and 12).

The tinfoil, thus wrapped about the support and clamped, is next brought to station II. Just before reaching this station, the projecting under side of the tinfoil hits against a block 181 (Figs. 1, 2, 13, 14 and 16), thereby tucking the lower end flap (Fig. 33). After this operation, the block 181 moves out of the way so that the upper end flap will not be affected. The block 181 is fastened to a slide 182 in a bracket 183 100 which is attached to the bracket 114, the slide being guided by a cover plate 184. A shaft 185 in the bracket-183 carries the lever 186, which is loosely engaged with a pin 187 on the under side of the slide bar 182. On the other end of the shaft 185 is clamped a lever 188 (Fig. 2), which is connected with a bell crank lever 189 by a rod 190. The bell crank lever 189 swings on a stud 191 located in a bearing 192 attached to the housing 52. An arm 193 of this lever is operated by a rod 194 which is connected with a bell crank cam lever 195 swinging on a shaft 196 held in the pedestal 42. An arm 197 of lever 195 is provided with a cam roller 198 engaged by a cam 199 on the shaft 47, thereby imparting a reciprocating motion to the slide bar 182 from the cam 199 through the motion transmitting linkage formed by the above described parts 197, 195, 194, 193, 189, 190, 188 (center of Fig. 3), 185, 186, 187, 182 (Figs. 13, 14, 15 and 16). The cam 199 is so timed that the end of lever 186 which engages the pin 187 and thereby reciprocates the slide 182 in bracket 183, moves the slide and with it the block 181 toward the end of the package support 63 a little before the package support arrives at this station, and withdraws the slide before said package support moves away therefrom.

If tinfoil side tucking separate from that of the pouch forming sheet (Fig. 34) is desired at this station, the parts which will now be described are added (Figs. 14, 15 and 16). Bracket 183 is provided with the side tuckers 200 which are carried by levers 201—202 and 203—204. The lever 201 swings on a stud 205, the levers 202 and 203 are mounted on shafts 206 and 207, and the lever 204 is mounted on a shaft 208. The shaft 208 which is supported in a bracket 209 attached to the bracket 114, carries a bevel gear 210 meshing with a bevel gear 211 on shaft 212. A lever 213 mounted on this shaft is connected by a rod 214 with a cam lever 215 swinging on the shaft 196 (Fig. 2). An arm 216 of the lever 215 has mounted on its end a roller 217 engaging with the cam 199, thereby producing reciprocating motion of the tuckers 200 as a pin 218 of a lever 219 on shaft 207 engages with a slot in lever 220 on the shaft 206.

After the tinfoil tucking operation, the folded and partly tucked tinfoil is advanced to station

III, at which means are provided for feeding a pouch sheet L underneath the support 63 in position to be circumferentially wrapped around same with its ends overlapping on the top side of the support. The pouch sheet is taken off a suitable sheet supply as a magazine and transport chain (not shown) by reciprocating pouch sheet transfer lever 222, which reciprocates from a position in front of the package sheet supply where it receives the pouch sheet to a position in which the pouch sheet is just below the support, in the position shown in Fig. 17. While on the transport chain, on its way from the pouch sheet magazine, the pouch sheet has had applied to it a stroke of paste on its upper edge for the side seam sealing of the pouch, and a daub of paste near the middle of its side edge for the end sealing of the pouch. The detailed construction of the transport chain, the pouch sheet magazine and the pasting mechanism does not form a part of the present invention, reference being made to my copending application No. 276,784, filed May 10, 1928, for a detailed disclosure of suitable means for this purpose.

The transfer device, which transfer the pouch forming sheet from the chain to the support, consists of a frame 220 which has two strips 221 for supporting the pouch sheet L. This frame is carried by two parallel levers 222 and 223 (Fig. 2), swinging on studs 224 carried in a bracket 225 attached to the under side of the table 40. The arm 226 of the lever 223 is connected by a rod 227 with a cam lever 228, which swings on a shaft 229 supported in the pedestal 42 and the bracket 45, and has on its end a roller 230 in engagement with a cam 231. While the pouch sheet is being transported by the transfer device to the under side 73 of support 63, clamp 69 is held open to clear the way for the sheet transfer by the action of a projecting lug 232 on lever 106 (Figs. 4 and 6), which engages with the pin 104 of the lever 103. The opening of clamp 69 at station III is simultaneous with the opening of clamp 69 at station XII, the levers 99 and 106 being connected together by the rod 105.

Upon reclosing of the clamps, the turret takes another step and the support comes to station IV, at which the pouch sheet folding takes place. In coming to this station, the overhanging flaps of the pouch sheet hit against two stationary rods 233 between which the support passes, and are thereby bent up about the support. These rods (Figs. 19 to 22) are located in a bracket 234 attached to the stand 54. Brushes 235 held by angle pieces 236 attached to bracket 234 hold the pouch sheet against the narrow sides of the support. A lever 237 swinging on a stud 238 has a folding plate 239 fastened to the rod 240 on the lever. A stud 238 is held by a bracket 241 attached to the table 40. An arm 242 of the lever 237 is pulled by a spring 243 fastened on a post 244 into engagement with a pin 245 on a bell crank lever 246, which is mounted on the shaft 165. The arm 247 of lever 246 carries an insulated folding plate 248 connected to the bell circuit hereinbefore described. In case of a missing pouch sheet, the plate 248 comes in contact with the tinfoil, thereby closing the bell circuit and giving an alarm.

The operation of the pouch sheet folding plates 239 and 248, which takes place simultaneously with the tinfoil folding at station I, is effected by the oscillating shaft 165 actuated by the fork lever 164 engaging with the cam lever

168. As the lever 247 carrying plate 248 moves towards the bent up pouch sheet flap, the pin 245 of the arm 246 releases the lever arm 242, which is pulled downward by the spring 243, thereby allowing the folding plate 239 to also move towards the bent up pouch sheet flap, the folding by plate 239 taking place in advance of that by plate 248, because the former is positioned nearer to the support than the latter.

As soon as the pouch sheet folds are partly made and the seam is pressed against wall 74 by the resilient finger 249 of plate 239, clamp 71 is opened to clear the way for folding the edges of the pouch sheet into overlapping position. The release of clamp 71 at station IV is effected simultaneously with the opening of clamp 71 at station I, the lever 150 having an arm 250 with a projecting lug 251 which bears against the pin 147 of the lever 148. As soon as the two edges of the pouch sheet are folded upon one another, the clamp 71 is again closed, causing the resilient spring plate 179 to smoothen and press the pasted top flap down upon the bottom flap. The strip 180 then comes to rest upon the pouch seam, while the plates 239 and 248 move back to their normal position.

The next step of the turret brings the support to station V (Figs. 23 to 26), at which the tucking and final folding of the pouch is performed. The tucking of the two narrow sides is done by side tuckers 252 which will either side tuck the pouch sheet separately (Fig. 35), similarly as the tinfoil is tucked at station II (Fig. 34), or side tuck the pouch sheet and tinfoil together (Fig. 33), depending on whether the tinfoil has been already tucked or not. The side tuckers 252 are carried by parallel levers 253—254 and 255—256. The lever 253 is loosely mounted on a stud 257, the lever 254 is fixedly mounted on a shaft 258 which carries the downwardly projecting arm 259 having on it a pin 260. The lever 255 is fixedly mounted on a shaft 261 which carries a slotted arm 262 engaging with the pin 260. The lever 256 is fixedly mounted on the shaft 212, having the fixed arm 213 to which reciprocating motion is imparted by the rod 214 actuated by cam 199. The shaft 212, through its bevel gear 211, also operates the side tucking of the tinfoil at station II. As soon as the side tucking is accomplished, an angle shaped end of lever 263 (Figs. 25, 26 and 27), folds one of the remaining end flaps 264, leaving the other end flap 265, which has a daub of paste on its under side, to be folded over by hitting a stationary roller 266, while the support is moved from station V to VI, thereby finishing the folding of the pouch.

Lever 263, which is pivoted on a stud 267 in a bracket 268 attached to the table 40, is actuated by a rod 269 (Figs. 1 and 2) connected to a lever 270 swinging on a stud 271 in a bracket 272 attached to the front of the table 40. The lever 270 is operated by a rod 273 attached to the cam lever 274 swinging on the shaft 229 and having roller 275 engaging with cam 231. An adjustable screw 276 in the bracket 268, bearing against a lug 277, limits the motion of the lever 263. A projecting lug 278 of bracket 268 has a pin 279 which carries the guide plate 280 engaging the partly sealed flaps, to prevent them from opening up. The roller 266 is held between two pointed screws 281 on the flap guide 280. Adjacent to guide 280 is the movable flap guide 282 which serves to prevent opening up of the partly sealed flaps, at-

tached to the block 283 on plunger 284, which slides in guide 285 attached to table 40.

This block 283 is lined with rubber, or other resilient material, and serves as an impacting element and at station VI gives the rotated end of the pouch an impact to lay the folds flat and insure complete sealing, the plunger 284 which bears against plunger 65 (Fig. 28) furnishing a supporting surface inside the pouch (Fig. 36). A stationary roller 286 (Fig. 7), attached to table 40, is located behind the arbor plunger 65 at station VI to absorb the impact and guard the plunger roller and cam track against possible damage. To absorb the recoil of the blow, the impacting plunger 284 is connected with a shock absorbing plunger 287 by a toggle joint 288 (Fig. 28). The plunger 287 is slidably mounted in housing 289 attached to table 40 and containing the spring 290. Rod 291 operates the toggle joint 288 by means of a bell crank 292 on a stud 293 in a bracket 294 attached to the under side of the table 40. A rod 295 connects the bell crank 292 with a cam lever 296 on shaft 229, a roller 297 on the last named lever engaging a cam 298 on the shaft 47.

To dry the paste with which the pouch is sealed, the turret, in its further advance, carries the sealed end of the pouch along a heated plate 299 (Figs. 28 to 31), the lower end of which is fastened to a bracket 300 held by a pin 301 on the reciprocating plunger 284. The upper end of the plate 299 is attached to a bracket 303 hinged on a frame 304 affixed to the supporting stand 54. During the forward stroke of plunger 284, when the turret is at rest, the heating plate 299 is pressed against the sealed pouch end, but on the return stroke of the plunger, when the turret is moving, the heating plate is held away from the pouch.

In order to suitably compact and present a group of cigarettes, or other articles, for insertion within the hollow support 63, a compacting device having pocket 62 holding the compressed group of cigarettes is provided. It will be observed that the front and rear parts of the turret are spaced sufficiently to admit the compactor pocket between their peripheral portions. The hollow supports on the peripheral portions of the front part of the turret and the plungers on the peripheral portion of the rear part of the turret are, when the plungers are in retracted position, spaced apart sufficiently to receive the group of cigarettes in the compressor pocket into aligned position between them.

The plunger is gradually withdrawn to its extreme retracted position ready to push the group of cigarettes into support 63 by the cam roller 137 as the support proceeds from station VI to station IX.

Since compacting devices having impacting pockets and suitable for use with the present machine are well known, as shown in the above mentioned Patent 1,608,163, only so much of the compacting device is shown as is necessary to make clear the relation between the compactor pocket 62 and the other parts of the machine.

The plunger 65 is now behind the compactor, its roller 137 having left the cam track 138 of the stationary cam 139 and entered the track 306 (center right of Fig. 7), cut into transfer plunger 307. The latter plunger is held in the guide 308 attached to housing 52 which has the slot 309 for the passage of the plunger. Plunger 307 is operated by lever 310 fulcrumed on stud 311 located in bracket 312 fastened to table 40.

Lever 310 is actuated by crank lever 313 connected with it by rod 314 mounted on shaft 315 held in the bearings 316 attached to the rear of table 40. The shaft 315, which carries the fixed spur gear 317, receives rocking motion from cam lever 318 which terminates in a gear segment 319 meshing with gear 317. Cam lever 318 has the roller 320 in engagement with cam 321 on shaft 47 and swings on stud 322 in bracket 323 attached to table 40.

A group of cigarettes C are pushed out of the compactor pocket 62 partway into the support by the forward movement of the plunger 65 at station IX, the face of the plunger stopping at the support entrance, as shown in dotted lines at station IX of Fig. 7, and then the plunger returns to its rearmost or retracted position.

The next three steps of the turret bring the cigarette filled support, with its surrounding container, past the stations X and XI to station XII. The cam roller 137, which has returned to the track 138 on leaving station IX, gradually forces the plunger 65 into the support, pushing the cigarettes to the end of the support, into contact with the end of the container. The group of cigarettes are now ready, upon the further forward motion of plunger 65 as will be hereinafter described, to push against the closed end of the container L to eject the latter from the support.

After leaving the movable heater plate 299, the sealed container ends are held closed by a stationary guide plate 324, (Figs. 30 and 31), held by a bar 325 attached to the frame 304.

Just before arriving at station XII, in order to prevent clogging of the plunger guideways on retraction of the plunger 65, it is cleaned of possible tobacco scraps by brushes 326 (Figs. 1, 3 and 4), which are fastened to a bar 327 held by one arm of a bell crank lever 328 and by a connecting bar 329 attached to an arm of a bracket 330. Lever 328 is mounted on the rocking shaft 331 held by brackets 330 and 332, the former attached to the housing 52 and the latter to table 40. The rocking motion of shaft 331 is produced by cam 333 on shaft 47 through roller 334 on cam lever 335 fulcrumed on stud 336 in pedestal 41 and connected by rod 337 with the crank lever 338 on shaft 331.

At station XII, for the purpose of giving the plunger its extreme forward movement and thus eject the group of cigarettes and the container from the support and complete the insertion of the former within the latter, the plunger roller 137 leaves the track 138 and enters a track provided in the reciprocating plunger 339 (Figs. 6 and 7). This also effects the transfer of the package thus formed into the entrance of the delivery guideway in the path of ejection of the package. The motion of the transfer plunger 339 is produced by a forked lever 340 swinging on a stud 341 in the stand 55. The lever 340 is connected with a plunger 339 by a pin 342 and is actuated by means of a rod 343 attached to a crank lever 344 fastened to the oscillating shaft 315. The plunger 339 is slidably held in a guide 345 mounted on the housing 52, which has a guide slot 346 (Fig. 3), in which the plunger slides.

Before the transfer plunger 339 starts its forward motion, the clamps 69 and 71 are opened to free the package. The clamp 69 is opened by the lug 102 pressing against the pin 104 on the lever 103, as previously described; the opening of clamp 71 is performed by the pin

145 on the lever 144 which engages with an inclined face 347 (Fig. 4), of the bracket 101.

To hold the package and insure smooth ejection from the support by plunger 339, the package is held between the support plunger 65 and a yieldably mounted plate 348 (Figs. 2, 6 and 31) attached to a rod 349, the end of which projects into a bore in a rod 350, in which it bears against a light spring 351. A pin 352 inserted in rod 349 and moving in a slot in the hollow end of rod 350 guides the plate 348 and limits its motion. Rod 350 is carried by two parallel levers 353 and 354 on studs 355 and 356 held by a bracket 357 attached to the stand 54. The movement of rod 350 is effected by an arm 358 of the lever 354, this arm being connected to a bell crank 359 by a rod 360. The bell crank 359 is pivoted on a stud 361 in a bracket 362 attached to the table 40. A rod 363 connects the bell crank 359 with a cam lever 364 swinging on shaft 229 and having a cam roller 365 in engagement with the cam 298.

The package, on its way from the arbor to the delivery chamber (Fig. 31), is guided by a stationary guide plate 366 attached to stand 54 and, upon arriving at the entrance of the delivery chamber, rests upon a bottom plate 367, of the delivery guideway and is held in position there for the final tinfoil tucking and folding between the reciprocating ejecting plunger 368, which also acts as guide, and the two movable retaining bars 369 and 370. Bar 369 is suitably bevelled to prevent catching on the corner of the package being ejected.

The final tinfoil tucking of the inner wrapper parts overhanging the end of the group of cigarettes is accomplished (Figs. 30 and 31) by folding devices located on opposite sides of the path of ejection of the package. These include upper and lower tuckers 371 and 372 carried by the links 373. The link 373 of the upper tucker 371 is held by two parallel levers 374 and 375, the former loosely mounted on stud 376, the latter fixedly mounted on shaft 377. The link 373 of the lower tucker 372 is supported by parallel levers 378 and 379, which are respectively fixedly mounted on a shaft 380, and loosely mounted on stud 381. Stud 376 and 381, and shafts 377 and 380 are located in the frame 304. An arm 382 of the lever 378 actuates the lower tucker, being connected by a rod 383 with a cam lever 384 swinging on a stud in the bracket 45 and having a roller 386 in engagement with a cam 387 on the shaft 47. The upper tucker is actuated by means of a lever 388, on the shaft 380, having a pin 389 in engagement with a slotted lever 390 on the shaft 377.

The folding of the end flap 391 (Fig. 37) is effected by a reciprocating folding plate 392 (Figs. 30, 31 and 32), which passes through a slot in the guide plate 366. The folding plate 392 is attached to an arm 393 carried by levers 394 and operated by an arm of bell crank 395 held by a stud 396, the bell crank 395 being actuated by a rod 397 (Figs. 1 and 2), fastened to a cam lever 398 swinging on a stud 399 in the bracket 45 and having a roller 400 in engagement with the cam 387.

The finished package, while being ejected into the delivery guideway of the machine by the plunger 368, is held in position by the supporting bars 369 and 370 and by a top guide bar 401 attached to a bracket 402 on the stand 54. The plunger 368 is carried by levers 403 and 404

pivoted on studs 396 and is operated by a rod 405 from a cam lever 406, having roller 407 in engagement with the cam 387. To allow the package to pass between the stationary side guide 141 attached to stands 54 and 114 and a movable side wall 408 of the delivery guideway, the retaining bars 369 and 370 are cleared out of the way at the proper time. The bar 369 is mounted on a bar 409 carried by parallel levers 410 and 411, loosely mounted on studs 412 and 413 held in the stand 54 and operated by a slotted lever 415 on a shaft 416, which is in engagement with the lever 411 by means of a pin carried by the latter. A shaft 416 has a two armed crank lever 417 and receives rocking motion by means of rod 418 connecting one arm of same with a bell crank lever 419 pivoted on a stud 420 and having a cam roller 421 in engagement with a cam 422 on the shaft 113. The other arm of the lever 417 is connected with a hinge 423 by means of a link 424. The hinge 423, together with a second hinge 425, carries the movable side wall 408, to which is attached the retaining bar 370 (Figs. 1 and 2). The hinge 423 swings on a stud 426 while the hinge 425 is fulcrumed on the shaft 416.

The bars 369 and 370 having cleared the entrance to the delivery chamber, the plunger 368 pushes the package P into said chamber, the remaining end flap 427 thereby hitting against the front edge of the side wall 141 of the guideway, which thus completes the closing of the tinfoil at the end of the package P (Fig. 38).

The machine is started and stopped by a clutch 428 which engages with a pulley 429 driven by a belt 430. The clutch 428 is actuated by a crank lever 431, swinging on a stud 432 in a bracket 433 attached to the pedestal 42, by means of a rod 434 guided in bracket 435 on table 40. Rod 434 has clamped to it a block 436 which is connected by a link 437 to a bell crank lever 438 swinging on a stud 439. A link 440 connects the lever 438 with a clutch shift lever 441 swinging on a stud 442. Handwheels 443 are provided to set the machine in motion when the clutch is disengaged, these handwheels being mounted on a shaft 444 located in bearings 445 attached to the pedestals 41 and 42. A sprocket 446 on shaft 444 has a drive chain 447 connecting it with a sprocket 448 on the drive shaft 46.

The construction and operation of the several parts of the machine have thus been described with respect to their co-operation with one of the supports 63. Since the several parts cooperate in exactly the same way with each of the twelve supports 63, it is deemed unnecessary to refer to the operation of the machine with respect to the other supports. Each of these supports has its individual plunger and set of clamps travelling therewith, and each of the supports in turn co-operates in exactly the same manner with the devices at the several folding, tucking and other stations at which the packaging operations are performed. It will be obvious then that a device at one of the stations described as operating once with respect to one of the supports, is interconnected with the drive of the turret so that the same operation is performed once every time a support arrives at that station, which in the particular machine illustrated occurs twelve times during one revolution of the turret.

What is claimed is:

1. The combination with a hollow support

- for receiving a group of articles to be packaged, of means for wrapping a plurality of layers of sheet material about said support to form a container, means for feeding sheet material to said wrapping means to form an inner wrapper, means spaced from said sheet feeding means for subsequently feeding sheet material to said wrapping means to form an outer wrapper, and means for subsequently inserting said group within said support and container including a compactor pocket arranged to hold the group of articles compacted and in alignment with said support.
2. The combination with a hollow support for receiving a group of articles to be packaged, of means for wrapping sheet material about said support to form a container, and means for subsequently inserting said group within said support and container, said wrapping means including mechanism for wrapping an inner wrapper about said support and means for therefore forming a pouch around said inner wrapper.
3. The combination with a hollow support for receiving a group of articles to be packaged, of means for wrapping a plurality of layers of sheet material about said support to form a container, means for feeding sheet material to said wrapping means to form an inner wrapper, means spaced from said sheet feeding means for subsequently feeding sheet material to said wrapping means to form an outer wrapper, and means for subsequently inserting said group within said support and container including a compactor pocket arranged to hold the group of articles compacted and in alignment with said support, said support including an open ended sheet metal box.
4. The combination with a hollow support for receiving a group of articles to be packaged, of means for wrapping sheet material about said support to form a container, means for subsequently inserting said group within said support and container, and an intermittently rotated turret carrying said support, said wrapping means including stationary folders cooperating with said support.
5. The combination with a hollow support for receiving a group of articles to be packaged, of means for wrapping a plurality of layers of sheet material about said support to form a container, means for feeding sheet material to said wrapping means to form an inner wrapper, means spaced from said sheet feeding means for subsequently feeding sheet material to said wrapping means to form an outer wrapper, and means for subsequently inserting said group within said support and container, said inserting means including a compactor pocket arranged to hold a compacted group of articles in alignment with said support, and a plunger acting to force the group into the support.
6. The combination with a hollow support for receiving a group of articles to be packaged, of means for wrapping sheet material about said support to form a container, means for feeding sheet material to said wrapping means to form an inner wrapper, means spaced from said sheet feeding means for subsequently feeding sheet material to said wrapping means to form an outer wrapper, means for subsequently inserting said group within said support and container including a compactor pocket arranged to hold the group of articles compacted and in alignment with said support, and ejector means operative to eject said container and group from the support without displacing the latter from its position within the former.
7. The combination with a hollow support for receiving a group of articles to be packaged, of means for wrapping sheet material about said support to form a container, and means for subsequently inserting said group within said support and container, said wrapping means including a clamp operative to clamp the mid portion of a wrapper sheet against one side of said support, mechanism for wrapping the wrapper sheet around said support with its ends overlapping on the opposite side of the support and another clamp operative to clamp said ends against the support.
8. The combination with a hollow support for receiving a group of articles to be packaged, of means for wrapping sheet material about said support to form a container, means for feeding sheet material to said wrapping means to form an inner wrapper, means spaced from said sheet feeding means for subsequently feeding sheet material to said wrapping means to form an outer wrapper, and means for subsequently inserting said group within said support and container including a compactor pocket arranged to hold the group of articles compacted and in alignment with said support, said wrapping means including means for closing and sealing one end of the container, and ejector means acting on said group to force the same against said end to eject the group and the container.
9. The combination with a hollow support for receiving a group of articles to be packaged, of means for wrapping a plurality of layers of sheet material about said support to form a container, means for feeding sheet material to said wrapping means to form an inner wrapper, means spaced from said sheet feeding means for subsequently feeding sheet material to said wrapping means to form an outer wrapper, and means for subsequently inserting said group within said support and container, said hollow support having an open end and said inserting means including a plunger operative during wrapping to provide a supporting surface at said end.
10. The combination with a hollow support for receiving a group of articles to be packaged, of means for wrapping a plurality of layers of sheet material about said support to form a container, means for feeding sheet material to said wrapping means to form an inner wrapper, means spaced from said sheet feeding means for subsequently feeding sheet material to said wrapping means to form an outer wrapper, and means for subsequently inserting said group within said support and container including a compactor pocket arranged to hold the group of articles compacted and in alignment with said support, said inserting means including a plunger operative after insertion of the group to eject the group and the container.
11. The combination with a hollow support for receiving articles to be packaged, of means for circumferentially wrapping an inner wrapper sheet and an outer pouch forming sheet around and overhanging one end of the support, and means for thereafter simultaneously folding the overhanging parts of both sheets over the end of the support.
12. Means for wrapping a sheet of material about an intermittently moving object comprising a clamp operative to clamp the mid portion

of the sheet against the front face of the object, and means for circumferentially wrapping said sheet about the object with two ends overlapping on the rear face, including spaced stationary folding elements between which the object moves, and a second clamp for clamping said ends.

13. A device for inserting a group of articles within a container having one open and one closed end, including a hollow open ended support within said container, means for inserting said group within the support and forcing the group and container off the support, said means including an ejector, mechanism for gradually moving the ejector to insert the group within the support, and mechanism for moving the ejector more rapidly to force the group and container off the support without displacing the former from within the latter.

14. A device for inserting a group of articles within a container having one open and one closed end, including a hollow open ended support within said container, means for inserting said group within the support and forcing the group and container off the support, without displacing the former from within the latter, said means including an ejector, mechanism for gradually moving the ejector to insert the group within the support, and mechanism for moving the ejector more rapidly to force the group and container off the support, said ejector operating to push the group against the closed end of the container.

15. Means for inserting groups of articles within open containers comprising an intermittently rotating turret, a series of reciprocating plungers thereon, a similar series of supports on said turret, each arranged to support a container with its open end in the range of action of one of the plungers but spaced therefrom when the latter is in retracted position, and compacting means for successively introducing the groups of articles in aligned position and compacted condition between said open ends and the plungers for insertion thereby.

16. In a packaging machine, means for impacting a folded and sealed portion of a package wrapper comprising an impacting element, means actuating said impacting element and shock absorbing means connected to said actuating means for controlling the impact.

17. In a packaging machine, the combination with a rotating turret, of package forming and ejecting means on said turret having a plurality of plungers, means for operating said plungers including a stationary cam track along the periphery of the turret, and a housing encircling the turret in which said cam track is formed.

18. The combination with a hollow support for receiving a group of articles and a wrapper surrounding the group and support, one end of said wrapper being open with the flaps overhanging the rear end of the group, of mechanism for ejecting the group and wrapper, a guideway transverse to the path of ejection with one end adjacent the position of an ejected package, means for folding the rear flaps of the ejected package and means for pushing the folded package out of folding position sidewise into said guideway to fold down the front flap of the ejected package.

19. In a packaging machine, the combination with a rotatably mounted disk, of a plurality of open ended hollow supports secured to said disk with their interiors extending substantially

parallel to the axis thereof, a drum secured to the first mentioned disk in spaced relation thereto, article carrying mechanism movable between said disk and drum, and means mounted on said drum for pushing groups of articles from said carrying mechanism into said supports.

20. In a packaging machine, the combination with a rotatably mounted disk, of a plurality of open ended hollow supports secured to said disk with their interiors extending substantially parallel to the axis thereof, a drum secured to the first mentioned disk in spaced relation thereto, article carrying mechanism movable between said disk and drum, means mounted on said drum for pushing groups of articles from said carrying mechanism into said supports, and means for subsequently operating said pushing means to push the articles out of the support.

21. In a packaging machine, the combination with a rotatably mounted disk, of a plurality of open ended hollow supports secured to said disk with their interiors extending substantially parallel to the axis thereof, a drum secured to the first mentioned disk in spaced relation thereto, article carrying mechanism movable between said disk and drum, means mounted on said drum for pushing groups of articles from said carrying mechanism into said supports, and means for forming containers about said supports and groups.

22. In a packaging machine, the combination with a rotating turret, of package forming and ejecting means arranged along the circumference of said turret provided with plungers, and a stationary camway extending circumferentially with respect to said turret for operating said plungers, said camway including a reciprocable section, and means for reciprocating said section to periodically increase the range of action of said plungers.

23. The combination with a progressively moving support for articles to be wrapped, of means for wrapping a sheet of material circumferentially about said support with the end of one flap overlapping that of the other, means for clamping said flap ends against the support, and means for smoothing the top flap over the under flap prior to clamping.

24. The combination with a progressively moving support for articles to be wrapped, of means for wrapping a sheet of material circumferentially about said support with the end of one flap overlapping that of the other, means for clamping said flap ends against the support, a spring finger projecting from said clamp arranged to engage the top flap and smooth the same over the lower flap prior to clamping.

25. In a packaging machine, the combination with mechanism for feeding a web of tinfoil, of a support, a device for clamping the leading end of the tin foil against said support, mechanism for severing the web while it is clamped to said support, and means for audibly apprising the operator when the tin foil web is torn or becomes slack.

26. In a packaging machine, the combination with mechanism for feeding a web of tinfoil, of a support, a device for clamping the leading end of the tin foil against said support, and means for audibly apprising the operator when the tin foil web is torn or becomes slack, said means including a bell circuit connected to said web feeding mechanism.

27. In a packaging machine, the combination with a hollow support, of mechanism for wrap-

80

85

90

95

100

105

110

115

120

125

130

135

140

145

150

ping a sheet of tin foil about said support, mechanism for wrapping a pouch sheet about said tin foil sheet, and means for audibly apprising the operator when the pouch sheet is missing on

5 said support.

28. In a packaging machine, the combination with a hollow support, of mechanism for wrapping a sheet of tin foil about said support, mechanism for wrapping a pouch sheet about said tin foil sheet, and means for audibly apprising

10 the operator when the pouch sheet is missing, said pouch wrapping mechanism including an insulated folding plate, and said means including a bell circuit connected to said folding plate.

29. The combination with a hollow support having open ends, of a clamp adapted to hold wrapping material against said support, means for opening said clamp, means for feeding a strip of wrapping material between said support and

15 clamp, means for closing said clamp to hold the strip against said support, means for severing said strip while it is clamped to said support, means for circumferentially folding the severed

20 strip about said support with one end overhanging the front end of said support and then folding said overhanging end over the front end of said support, and means for inserting a group of cigarettes into said support through the other

25 end thereof.

30. The combination with a hollow support having open ends, of a clamp adapted to hold wrapping material against said support, means for opening said clamp, means for feeding a strip of wrapping material between said support and

35 clamp, means for closing said clamp to hold the strip against said support, means for severing said strip while it is clamped to said support, means for circumferentially folding the severed strip about said support with one end

40 overhanging the front end of said support and then folding said overhanging end over the front end of said support, and means for inserting a group of cigarettes into said support through the other end thereof, said means for circumferentially

45 folding the severed strip about said support including folding plates and means for actuating said plates to overlap the edges of the severed strip on said support, and said clamp carrying means for smoothing out the wrapper.

31. The combination with a hollow support having open ends, of a clamp adapted to hold wrapping material against said support, means for opening said clamp, means for feeding a strip of wrapping material between said support and

50 clamp, means for closing said clamp to hold the strip against said support, means for severing said strip while it is clamped to said support, means for circumferentially folding the severed strip about said support with one end overhanging

55 the front end of said support and then folding said overhanging end over the front end of said support, and means for inserting a group of cigarettes into said support through the other end thereof, said means for circumferentially

60 folding the severed strip about said support including a pair of resilient folding plates and means for actuating said folding plates to overlap the edges of the severed strip on said support.

32. The combination with a hollow support having open ends, of a clamp adapted to hold wrapping material against said support, means for opening said clamp, means for feeding a strip of wrapping material between said support and

65 clamp, means for closing said clamp to hold the strip against said support, means for severing

said strip while it is clamped to said support, means for circumferentially folding the severed strip about said support with one end overhanging the front end of said support and then folding

70 said overhanging end over the front end of said support, and means for inserting a group of cigarettes into said support through the other end thereof, said end folding means including a block adapted to tuck the lower end flap of said overhanging end.

33. The combination with a hollow support having open ends, of a clamp adapted to hold wrapping material against said support, means for opening said clamp, means for feeding a strip of wrapping material between said support and

75 clamp, means for closing said clamp to hold the strip against said support, means for severing said strip while it is clamped to said support, means for circumferentially folding the severed strip about said support with one end overhanging the front end of said support and then folding

80 said overhanging end over the front end of said support, and means for inserting a group of cigarettes into said support through the other end thereof, said end folding means including side tuckers adapted to tuck the sides of said overhanging end and levers connected to said tuckers and to each other.

34. The combination with a rotating turret, of a support on said turret, means for feeding

85 a sheet of wrapping material to said support and clamping it thereto with its edges overhanging said support, and spaced stationary rods adjacent the path of said support to fold the edges of the wrapping material about the support.

35. The combination with a support, of means for folding an inner wrapper circumferentially about said support with its ends overhanging the ends of said support and then folding one of said overhanging ends over the adjacent end of said support leaving the upper end flap of said overhanging end outstanding from said support, and means for circumferentially folding an outer wrapper about said support with one end overhanging said folded end and then folding said

90 overhanging end of the outer wrapper over the folded end of the inner wrapper together with said outstanding flap of the inner wrapper.

36. The combination with a support, of means for folding an inner wrapper circumferentially about said support with its ends overhanging the ends of said support and then folding one of said overhanging ends over the adjacent end of said support leaving the upper end flap of said overhanging end outstanding from said support, and means for circumferentially folding

95 an outer wrapper about said support with one end overhanging said folded end and then folding said overhanging end of the outer wrapper over the folded end of the inner wrapper together with said outstanding flap of the inner wrapper, said outer wrapper folding means including side tuckers for tucking the sides of the overhanging end of said outer wrapper, a lever having an angle shaped end for folding

100 down one of the remaining end flaps of said outer wrapper, and a stationary roller for folding down the other end flap of said outer wrapper and the outstanding flap of said inner wrapper.

37. The combination with a support, of means for pasting one end and edge of a pouch sheet and feeding the pasted pouch sheet to said support, means for circumferentially folding the pouch sheet about said support to overlap its

80

85

90

95

100

105

110

115

120

125

130

135

140

145

150

edges and form a pasted seam, means for folding the pasted end of the pouch sheet over the end of said support to form a sealed end, and means for impacting said sealed end to lay the folds flat and insure complete sealing.

38. The combination with a support, of means for pasting one end and edge of a pouch sheet and feeding the pasted pouch sheet to said support, means for circumferentially folding the pouch sheet about said support to overlap its edges and form a pasted seam, means for folding the pasted end of the pouch sheet over the end of said support to form a sealed end, and means for impacting said sealed end to lay the folds flat and insure complete sealing, said impacting means including an impacting plunger, a yieldingly mounted shock absorbing plunger, and a toggle connecting said plungers.

39. The combination with a support, of means for pasting one end and edge of a pouch sheet and feeding the pasted pouch sheet to said support, means for circumferentially folding the pouch sheet about said support to overlap its edges and form a pasted seam, means for folding the pasted end of the pouch sheet over the end of said support to form a sealed end, means for impacting said sealed end to lay the folds flat and insure complete sealing, and means for drying the sealed end of said pouch.

40. The combination with a hollow support adapted to receive a group of cigarettes, of means for wrapping a sheet of tinfoil about said support with its ends overhanging the ends of said support and folding one of the overhanging ends over the front end of said support, means for wrapping a pouch sheet circumferentially about said support with one edge even with the rear end of said support and the other end overhanging the folded end of the tinfoil wrapper and folding the overhanging end of the pouch sheet over the folded end of the tinfoil wrapper, means for pushing a group of cigarettes through said support against the closed ends of said tinfoil wrapper and pouch sheet to eject them from said support to produce a package having a tinfoil wrapper and a pouch sheet folded over one end of the package with the other end of the tinfoil wrapper overhanging the other end of the package, and mechanism for folding the overhanging end of the tinfoil wrapper over the adjacent end of the package.

41. The combination with a hollow support adapted to receive a group of cigarettes, of means for wrapping a sheet of tinfoil about said support with its ends overhanging the ends of said support and folding one of the overhanging ends over the front end of said support,

means for wrapping a pouch sheet circumferentially about said support with one edge even with the rear end of said support and the other end overhanging the folded end of the tinfoil wrapper and folding the overhanging end of the pouch sheet over the folded end of the tinfoil wrapper, means for pushing a group of cigarettes through said support against the closed ends of said tinfoil wrapper and pouch sheet to eject them from said support to produce a package having a tinfoil wrapper and a pouch sheet folded over one end of the package with the other end of the tinfoil wrapper overhanging the other end of the package, and mechanism for folding the overhanging end of the tinfoil wrapper over the adjacent end of the package, said mechanism including means for supporting the package, means for tucking the sides of the overhanging end of the tinfoil wrapper, means for folding over one of the remaining end flaps of said overhanging end while engaged by said support means, a delivery guideway having a side wall adapted to fold over the remaining end flap of said overhanging end, and means for forwarding the package into said guideway to fold over the remaining end flap of said overhanging end.

42. The combination with a rotary turret having a plurality of hollow supports fixed thereto and adapted to receive a group of cigarettes, of means for feeding tinfoil wrappers and pouch sheets to said supports at different stations of said turret, clamps adapted to hold the tinfoil wrappers to each support and the pouch sheets to the tinfoil wrapper on each support, means for folding the tinfoil wrappers about said supports and the pouch sheets about the tinfoil wrapper on each support, means for folding one end of the tinfoil wrappers and pouch sheets over the front end of said supports, means for pushing a group of cigarettes through said supports against the folded end of the tinfoil wrapper and pouch sheet to remove them from said supports and produce a package containing the cigarettes, and means for opening and closing said clamps to permit the tinfoil wrappers and pouch sheets to be wrapped around the supports and to be removed therefrom.

43. In a packaging machine, the combination with a support for a group of articles and a wrapper surrounding the group with an end of the wrapper open and overhanging an end of the group, of two sets of parallel levers, a side tucker carried by each set of parallel levers and adapted to tuck the sides of the wrapper, and means for actuating both sets of parallel levers simultaneously to cause said tuckers to fold in both sides of the wrapper simultaneously.

WILHELM B. BRONANDER.

5

10

15

20

25

30

35

40

45

50

55

60

65

70

75

80

85

90

95

100

105

110

115

120

125

130

135

140

145

150