

(19) World Intellectual Property Organization
International Bureau



(43) International Publication Date
11 September 2009 (11.09.2009)

PCT

(10) International Publication Number
WO 2009/111420 A1

- (51) **International Patent Classification:**
C03B 37/027 (2006.01) C03B 37/075 (2006.01)
- (21) **International Application Number:**
PCT/US2009/035792
- (22) **International Filing Date:**
3 March 2009 (03.03.2009)
- (25) **Filing Language:** English
- (26) **Publication Language:** English
- (30) **Priority Data:**
12/042,549 5 March 2008 (05.03.2008) US
- (71) **Applicant (for all designated States except US):** THE BOEING COMPANY [US/US]; 100 North Riverside Plaza, Chicago, IL 60606-2016 (US).
- (72) **Inventors; and**
- (75) **Inventors/Applicants (for US only):** WILENSKI, Mark, S. [US/US]; 9826 62nd Avenue S, Seattle, WA 98118 (US). LANG, Adam, J. [US/US]; 21050 Lochlea Lane, #78, Huntington Beach, CA 92646 (US). MARKUS, Alan, M. [US/US]; 22145 Timberline Way, Lake Forest, CA 92630 (US). GODBY, Larry, A. [US/US]; 9724 Columbus Avenue, North Hills, CA 91343 (US).
- (74) **Agents:** TSUDA, Diane, M. et al.; The Boeing Company, P.O. Box 2515, MC 110-SD54, Seal Beach, CA 90740-1515 (US).

- (81) **Designated States (unless otherwise indicated, for every kind of national protection available):** AE, AG, AL, AM, AO, AT, AU, AZ, BA, BB, BG, BH, BR, BW, BY, BZ, CA, CH, CN, CO, CR, CU, CZ, DE, DK, DM, DO, DZ, EC, EE, EG, ES, FI, GB, GD, GE, GH, GM, GT, HN, HR, HU, ID, IL, IN, IS, JP, KE, KG, KM, KN, KP, KR, KZ, LA, LC, LK, LR, LS, LT, LU, LY, MA, MD, ME, MG, MK, MN, MW, MX, MY, MZ, NA, NG, NI, NO, NZ, OM, PG, PH, PL, PT, RO, RS, RU, SC, SD, SE, SG, SK, SL, SM, ST, SV, SY, TJ, TM, TN, TR, TT, TZ, UA, UG, US, UZ, VC, VN, ZA, ZM, ZW.
- (84) **Designated States (unless otherwise indicated, for every kind of regional protection available):** ARIPO (BW, GH, GM, KE, LS, MW, MZ, NA, SD, SL, SZ, TZ, UG, ZM, ZW), Eurasian (AM, AZ, BY, KG, KZ, MD, RU, TJ, TM), European (AT, BE, BG, CH, CY, CZ, DE, DK, EE, ES, FI, FR, GB, GR, HR, HU, IE, IS, IT, LT, LU, LV, MC, MK, MT, NL, NO, PL, PT, RO, SE, SI, SK, TR), OAPI (BF, BJ, CF, CG, CI, CM, GA, GN, GQ, GW, ML, MR, NE, SN, TD, TG).

Published:

— with international search report (Art. 21(3))

(54) **Title:** GLASS FIBERS HAVING IMPROVED STRENGTH

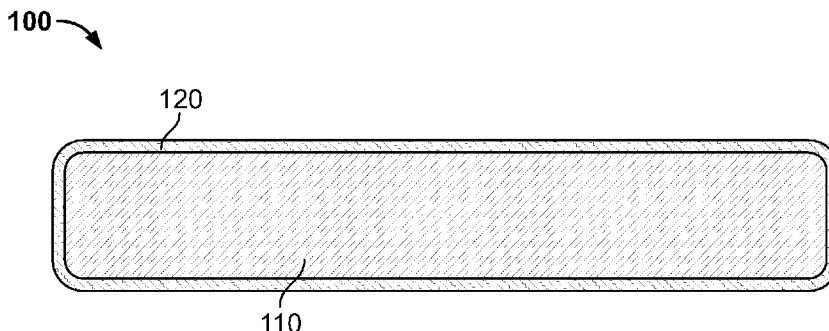

FIG. 1

(57) **Abstract:** A glass fiber and a method of manufacturing a glass fiber for reinforcing a transparent composite matrix are disclosed. The glass fiber includes a first glass material having a first set of mechanical properties including a first modulus and a first coefficient of thermal expansion (CTE) and a second glass material having a second set of mechanical properties including a second modulus and a second CTE. The second glass material forms a substantially uniform coating on the first glass material. The second CTE is less than the first CTE. The glass fiber is formed by reducing the cross-section of a glass fiber preform of the first glass material coated with the second glass material by hot working. Because of the selected difference in the CTE's, the first glass material imparts a compressive force upon the second glass material, which improves the strength of the glass fiber.

WO 2009/111420 A1

GLASS FIBERS HAVING IMPROVED STRENGTH

FIELD

The present disclosure is directed to transparent reinforcing materials and reinforced composite materials, more particularly to transparent glass fibers used in composite materials and to a process for producing such fibers.

BACKGROUND

Transparent composite materials are known for use in vehicle and other applications requiring light transmission or visual transparency. Such transparent composite materials include windows or other transparent materials useful for light transmission there through, particularly in rugged environments and in locations requiring ballistic resistance. Such reinforcement further provides the window or transparent device with improved strength.

Transparent composite materials typically include a reinforcing fiber in a polymeric matrix. In order to render the composite material transparent, both the matrix material and the reinforcing fiber are fabricated from a transparent material. The materials are typically selected to include the same optical properties, thus minimizing distortion.

The geometry of reinforcing fibers also affects the distortion imparted to the light passing through the transparent device. For example, round fibers (i.e., fibers having a circular cross-section) provide prismatic or other optical light refractive effects that provide overall distortion of the light passing through the transparent device.

These transparent composite materials are also required to withstand high impacts and structural loads, and thus are required to have high strength properties. The strength of these composite materials is dependent upon both the strength of the matrix material and the reinforcing fibers.

The strength of the reinforcing fibers is determined by the fiber material, geometry and characteristics imparted to the fibers during manufacture, such as surface

cracks, imperfections, and other inconsistencies.

What is needed is a fiber reinforcing material having improved surface characteristics over the prior art.

5 SUMMARY

A first aspect of the disclosure includes a glass fiber for reinforcing a transparent composite matrix. The fiber includes a first glass material having a first set of optical characteristics including, but not limited to, a first refractive index (RI), a first modulus of elasticity (modulus), and a first coefficient of thermal expansion (CTE), and a second
10 glass material having a second set of optical properties including, but not limited to, a second RI, a second modulus, and second CTE. The second glass material forms a substantially uniform coating on the first glass material. The second CTE is less than the first CTE.

Another aspect of the disclosure includes a method for fabricating a glass fiber
15 for reinforcing a transparent composite matrix including providing a first glass fiber preform having a first RI, a first modulus, and a first CTE, coating a second glass material having a second RI, second modulus, and a second CTE, substantially around a cross-section of the first glass material to form an initial coated glass fiber preform having an initial cross-section, and hot working the initial coated glass fiber preform to
20 reduce the initial cross-section to a final cross-section of the glass fiber. The second CTE is selected to be less than the first CTE.

Other features and advantages of the present disclosure will be apparent from the following more detailed description of the preferred embodiment, taken in conjunction with the accompanying drawings which illustrate, by way of example, the
25 principles of the disclosure.

BRIEF DESCRIPTION OF THE DRAWINGS

FIG. 1 shows a schematic cross-section view of a glass fiber according to an exemplary embodiment of the disclosure.

Fig. 2 shows an exemplary method of forming a glass fiber according to the disclosure.

DETAILED DESCRIPTION OF THE DISCLOSURE

"Transparent", "transparency" and grammatical variations thereof include an ability of a material to permit passage of at least a portion of light directed at the material, the term "light" including any wavelength range of interest, and more particularly to the visible, near visible and near infra-red light ranges from about 380nm to about 1000nm.

Referring to Fig. 1, a cross-section view of an exemplary glass fiber 100 according to the disclosure is shown. As can be seen in Fig. 1, glass fiber 100 includes a first glass material 110 and a second glass material 120. The second glass material 120 forms a substantially uniform coating around the first glass material 110. The glass fiber 100 has a generally rectangular cross-section geometry having a total thickness T , a first material thickness T_1 , a second glass material coating thickness T_2 , and a width W . The first glass material 110 and the second glass material 120 may both be transparent glass. In one embodiment, the first glass material 110 and the second glass material 120 may both be transparent optical glass.

In alternative embodiments, the glass fiber 100 may have a different cross-section geometry, for example, but not limited to generally square, generally oval, generally round and other similar geometries.

In one embodiment, the glass fiber 100 has a total thickness T of between about 1 μm to about 500 μm with an aspect ratio of width W to total thickness T of between about 5 and about 500. In another embodiment, the glass fiber 100 has a total thickness T of between about 5 μm and about 50 μm with an aspect ratio of width W to total thickness T of between about 10 and about 50.

In one embodiment, the second glass material coating thickness T_2 is between about 0.1% and about 100% the first glass material thickness T_1 . In another embodiment, the second glass material coating thickness T_2 may be between about 50 nm and about 5 μm . In yet another embodiment, the second glass material coating thickness T_2 may be between about 50 nm and about 1 μm .

In another embodiment, the glass fiber 100 has a width W of between about 5 μm and 5000 μm and an aspect ratio of width W to total thickness T of between about 5 and about 500. In yet another embodiment, the glass fiber 100 has a width of between about 100 μm to about 500 μm and an aspect ratio of width W to total thickness T of between about 10 and about 30.

The first glass material 110 is selected to have a first set of properties, including but not limited to a first RI, a first Abbe number, a first transmission, a first modulus and a first CTE. The second glass material 120 is selected to have a second set of properties, including, but not limited to a second RI, a second Abbe number, a second transmission, a second modulus and a second CTE. The second CTE is selected to be less than the first CTE.

The second glass material 120 must be chemically compatible with the first glass material 110. Furthermore, the second glass material 120 must not contain elements that will negatively affect the desirable properties of the first glass material 110 during the method of forming the glass fiber 100 or in the glass fiber 100.

Additionally, the second glass material 120 must be thermally compatible with the first glass material 110 to facilitate forming the fiber 100. For example, the second glass material 120 must have approximately the same viscosity versus temperature profile at hot working temperatures as the first glass material.

In one embodiment, the second CTE is between about 0% to about 100% less than the first CTE. In yet another embodiment, the second CTE is between about 70% to about 90% less than the first CTE.

In one embodiment, the first RI is approximately equal to the RI of a polymeric material in which the glass fiber 100 is used to form a composite structure. The composite structure may be a window. In another embodiment, the first RI is

substantially different from the second RI. In yet another embodiment, the first RI is approximately equal to the second RI.

In another embodiment, the second modulus is about equal to or less than the first modulus. In another embodiment, the second modulus is between about equal and
5 about 60% less than the first modulus.

In one embodiment, the second glass material has approximately the same optical performance as the first glass material. The second glass material may also have approximately the same viscosity versus temperature profile at hot working temperatures as the first glass material to facilitate forming the glass fiber.

10 The glass fiber 100 may be formed by the following exemplary embodiment as shown in Fig. 2. First, a first glass material preform of the first glass material is formed having a desired cross-section geometry and aspect ratio to provide a first glass fiber preform as shown in step 200. The cross-section of first material glass preform may be generally rectangular, generally square, generally circular, or other similar shape. The
15 first glass material preform may be formed by drawing, spinning, machining or other similar process.

The first glass material preform is then coated with a substantially uniform coating of the second glass material as shown in step 210. The first glass material may be chosen for a desired optical performance. The second glass material is chosen for
20 it's lower CTE compared to the CTE of the first glass material.

The second glass material may be coated onto the first glass material preform by slumping, chemical vapor deposition, plasma vapor deposition, sol-gel processing, slurry coating, or other similar process. Alternatively, a coating of the second glass material may be formed on the first glass material preform by modifying the surface
25 composition of the first material preform by methods such as, but not limited to, reactive chemical diffusion. By forming the second glass material by modifying the surface of the first glass material preform composition, the second material has a compositional gradient varying from that of the surface of the coated first glass material preform to the first glass material preform composition. The material properties of the modified surface
30 would also have a gradient from the properties of the second glass material at the

surface to the properties of the first glass material preform material at some predetermined distance from the surface. The composition and property gradient may be abrupt or gradual in nature.

5 In one embodiment, the first glass material preform has a generally rectangular cross-section having a thickness of between about 0.5 mm and about 12.7 cm and an aspect ratio of width to thickness of between about 5 and about 500.

In another embodiment, the second glass material coating thickness on the first glass material preform is between about 1 μm and 25.4 mm.

10 In another embodiment, the second glass material coating thickness is between about 0.1% and about 100% the thickness of the first glass material preform.

The coated glass fiber preform is then drawn under heat and pressure by methods well known in the art to form a glass fiber having a rectangular cross-section geometry having a total thickness, a first material thickness, a second glass material coating thickness, and a width as discussed above as shown in step 220. The glass
15 fiber may be formed in a continuous, semi-continuous, or step process. In one embodiment, the coated glass fiber is provided as a stock material that is later drawn to form a glass fiber.

The glass fiber may be used with an epoxy resin or other polymer to form a composite structure, such as a window, by methods appreciated by one of ordinary skill
20 in the art.

In one embodiment, the formed glass fiber has a second glass material coating thickness between about 0.1% and about 100% the first glass material thickness. In another embodiment, the second glass material coating thickness may be between about 50 nm and about 5 μm . In yet another embodiment, the second glass material
25 coating thickness may be between about 50 nm and about 1 μm .

In another embodiment, the formed glass fiber has a total thickness of between about 1 μm to about 500 μm with an aspect ratio of width to total thickness of between about 5 and about 500. In another embodiment, the formed glass fiber has a total

thickness of between about 5 um and about 50 um with an aspect ratio of width to total thickness of between about 10 and about 50.

In another embodiment, the formed glass fiber has a width of between about 5 um and 5000 um and an aspect ratio of width to total thickness of between about 5 and about 500. In yet another embodiment, the glass fiber 100 has a width of between about 100 um to about 500 um and an aspect ratio of width to total thickness of between about 10 and about 30.

To form the glass fiber, the first glass material is selected to have a first set of optical properties, including but not limited to a first RI, a first Abbe number, a first transmission, a first modulus and a first CTE, and the second glass material is selected to have a second set of optical properties, including, but not limited to a second RI, a second Abbe number, a second transmission, a second modulus and a second CTE. The second CTE is selected to be less than the first CTE.

The second glass material 120 must be chemically compatible with the first glass material 110. Furthermore, the second glass material 120 must not contain elements that will negatively affect the desirable properties of the first glass material 110 during the method of forming the glass fiber 100 or in the glass fiber 100.

Additionally, the second glass material 120 must be thermally compatible with the first glass material 110 to facilitate forming the fiber 100. For example, the second glass material 120 must have approximately the same viscosity versus temperature profile at hot working temperatures as the first glass material.

In one embodiment, the formed glass fiber includes a second glass material having a second CTE between about 0% to about 100% less than the first CTE. In yet another embodiment, the second CTE is between about 70% to about 90% of the first CTE.

In another embodiment, the formed glass fiber includes a first glass material having a first modulus and a second glass material having a second modulus, the second modulus is about equal to or less than the first modulus. In another embodiment, the second modulus is between about equal and about 60% less than the first modulus.

In one embodiment, the formed glass fiber has a first RI approximately equal to the RI of a polymeric material in which the glass fiber 100 is used to form a composite structure. The composite structure may be a window. In another embodiment, the first RI is substantially different from the second RI. In yet another embodiment, the first RI is approximately equal to the second RI.

In one embodiment, the formed glass fiber has a first glass material having approximately the same optical performance as the second glass material. In another embodiment, the formed glass fiber has a first glass material having approximately the same viscosity versus temperature profile at hot working temperatures as the second glass material.

In one example, a glass fiber is formed by selecting an optical glass N-SSK8 produced by SCHOTT North America, Inc., of Elmsford, NY, as a first glass material. This optical glass has a set of optical properties, including but not limited to an RI, a Abbe number, a transmission, a modulus and a CTE of $7.21 \text{ e}^{-6}/\text{C}$. A second glass material, having a lower CTE is then used to coat the first glass material and form a glass fiber. The second glass material is selected to be chemically compatible with the first glass material. Additionally, the second glass material is selected to be thermally compatible with the first glass material to facilitate forming the glass fiber. For example, the second glass material must have approximately the same viscosity versus temperature profile at hot working temperatures as the first glass material.

During the hot forming of the glass fiber, the second glass material, because of the lower CTE, will impart a tensile force upon the first glass material during and after cooling. This results in the second glass material having compressive stresses after formation. Because the strength of the glass fiber is directly related to the presence and growth of inconsistencies on the outer surface, the strength of the glass fiber will be increased by mismatching the CTE's of the first and second glass materials, as discussed above. This is because the compressive stress formed in the second glass material because of the shrinkage will cause the second glass material to resist crack formation and crack propagation.

While the disclosure has been described with reference to a preferred embodiment, it will be understood by those skilled in the art that various changes may

be made and equivalents may be substituted for elements thereof without departing from the scope of the disclosure. In addition, many modifications may be made to adapt a particular situation or material to the teachings of the disclosure without departing from the essential scope thereof. Therefore, it is intended that the disclosure not be limited to the particular embodiment disclosed as the best mode contemplated for carrying out this disclosure, but that the disclosure will include all embodiments falling within the scope of the appended claims.

CLAIMS

1. A glass fiber for reinforcing a transparent composite matrix, comprising:
 - a first glass material (110) having a first refractive index, a first modulus, and a first coefficient of thermal expansion; and
 - 5 a second glass material (120) having a second refractive index, a second modulus, and second coefficient of thermal expansion, the second glass material forming a substantially uniform coating on the first glass material;
 - wherein the second coefficient of thermal expansion is less than the first coefficient of thermal expansion.
- 10 2. The glass fiber of claim 1, wherein the second coefficient of thermal expansion is between about 0% and about 100% less than the first coefficient of thermal expansion.
3. The glass fiber of claim 1, wherein the second coefficient of thermal expansion is between about 70% and about 90% of the first coefficient of thermal expansion.
- 15 4. The glass fiber of claim 1, wherein the second modulus is between about equal and about 60% less than the first modulus.
5. The glass fiber of claim 1, wherein the first refractive index is approximately equal to the second refractive index.
6. The glass fiber of claim 1, wherein the first refractive index is substantially different
- 20 from the second refractive index.
7. The glass fiber of claim 1, wherein the glass fiber has a cross-section geometry selected from the group comprising a substantially rectangular geometry, a substantially circular geometry, a substantially oval geometry, and a substantially square geometry.
- 25 8. The glass fiber of claim 6, wherein the cross-section geometry is a substantially rectangular geometry.
9. The glass fiber of claim 7, wherein the glass fiber has a total thickness of between about 1 μm to about 500 μm and an aspect ratio of width to total thickness of between about 5 and about 500.
- 30 10. A composite comprising a glass fiber of claim 1.

11. A method for fabricating a glass fiber for reinforcing a transparent composite matrix, comprising:
- 5 providing a first glass fiber preform comprising a first glass material having a first refractive index, a first modulus and a first coefficient of thermal expansion (200); and
- coating the first glass fiber preform with a second glass material having a second refractive index, a second modulus and a second coefficient of thermal expansion to form a glass fiber preform having an initial cross-section with a preform total thickness (210); and
- 10 hot working the glass fiber preform to reduce the initial cross-section to a final cross-section having total thickness, a thickness of the first glass material, and a substantially uniform coating thickness of the second glass material;
- wherein the second coefficient of thermal expansion is less than the first coefficient of thermal expansion (220).
- 15 12. The method of claim 11, wherein the second coefficient of thermal expansion is between about 0% and about 100% less than the first coefficient of thermal expansion.
13. The method of claim 11, wherein the second coefficient of thermal expansion is between about 70% and about 90% of the first coefficient of thermal expansion.
- 20 14. The method of claim 11, wherein the second modulus is between about equal and about 60% less than the first modulus.
15. The method of claim 11, wherein the glass fiber has a cross-section geometry selected from the group comprising a substantially rectangular geometry, a substantially circular geometry, a substantially oval geometry, and a substantially
- 25 square geometry.
16. The method of claim 15, wherein the cross-section geometry is a substantially rectangular geometry.
17. The method of claim 16, wherein the glass fiber has a total thickness of between about 1 μm to about 500 μm and an aspect ratio of width to total thickness of
- 30 between about 5 and about 500.

18. The method of claim 15, wherein the glass fiber has a total thickness of between about 5 μm and about 50 μm and an aspect ratio of width to total thickness of between about 10 and about 50.
19. The method of claim 11, wherein the hot working is selected from the group
5 comprising extrusion, co-extrusion, hot drawing, spinning, and co-spinning.
20. The method of claim 11, wherein the glass fiber is formed into a composite window.

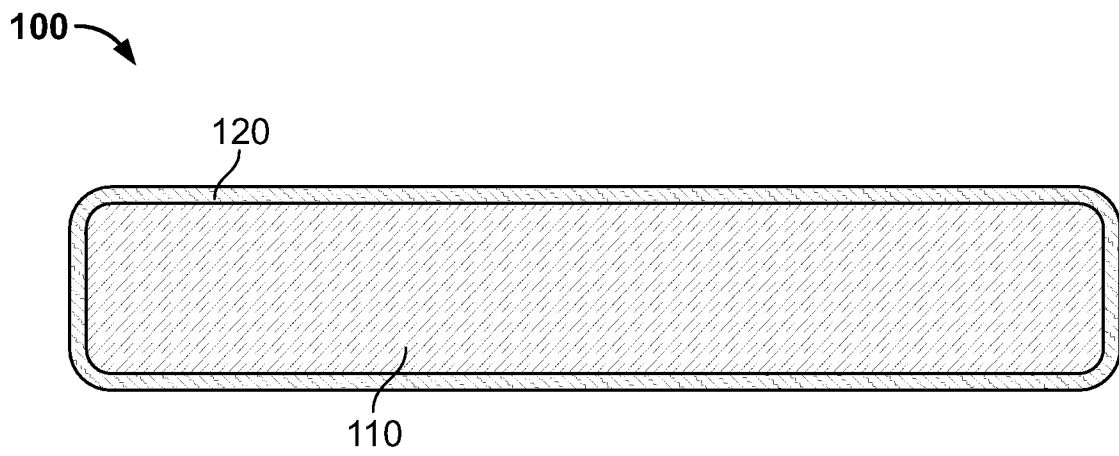

FIG. 1

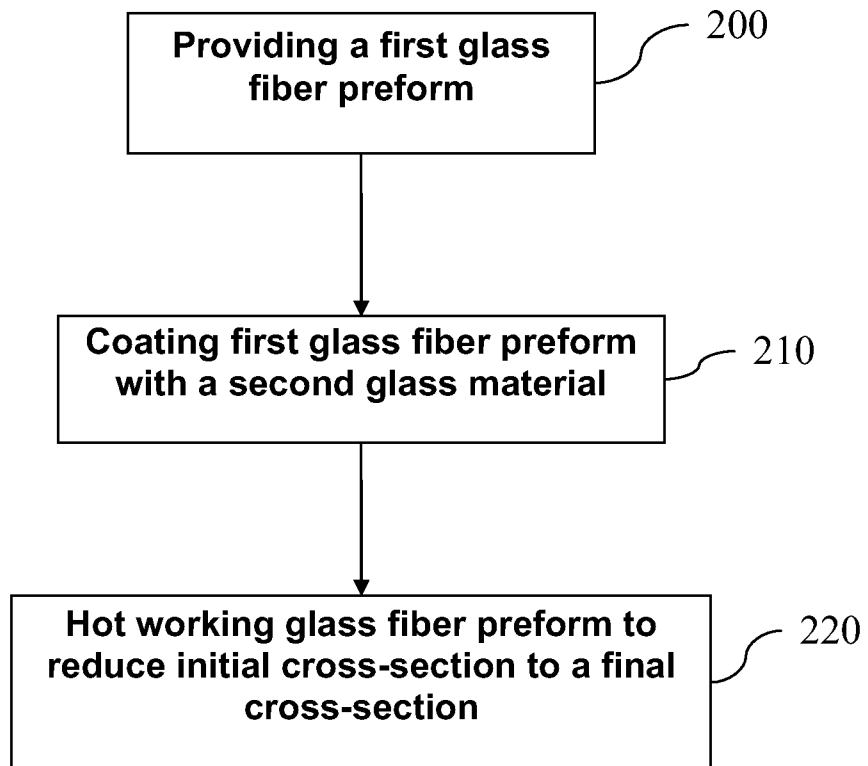

Fig. 2

INTERNATIONAL SEARCH REPORT

International application No
PCT/US2009/035792

A. CLASSIFICATION OF SUBJECT MATTER
INV. C03B37/027 C03B37/075

According to International Patent Classification (IPC) or to both national classification and IPC

B. FIELDS SEARCHED

Minimum documentation searched (classification system followed by classification symbols)
C03B

Documentation searched other than minimum documentation to the extent that such documents are included in the fields searched

Electronic data base consulted during the international search (name of data base and, where practical, search terms used)

EPO-Internal

C. DOCUMENTS CONSIDERED TO BE RELEVANT

Category*	Citation of document, with indication, where appropriate, of the relevant passages	Relevant to claim No.
X	US 4 354 736 A (MAKLAD MOKHTAR S ET AL) 19 October 1982 (1982-10-19) figure 6 -----	1-20
X	GB 1 503 793 A (ZEISS STIFTUNG [DE]) 15 March 1978 (1978-03-15) page 1, columns 39-51 -----	1-20
X	EP 0 801 039 A (SAINT GOBAIN ISOVER [FR]) 15 October 1997 (1997-10-15) column 4, lines 12-46 column 5, lines 15-23 -----	1-20
X	US 2 992 517 A (HICKS JR JOHN W) 18 July 1961 (1961-07-18) column 7, lines 23-40; figures 2,3,8,9 ----- -/--	1-20

Further documents are listed in the continuation of Box C.

See patent family annex.

* Special categories of cited documents:

- *A* document defining the general state of the art which is not considered to be of particular relevance
- *E* earlier document but published on or after the international filing date
- *L* document which may throw doubts on priority claim(s) or which is cited to establish the publication date of another citation or other special reason (as specified)
- *O* document referring to an oral disclosure, use, exhibition or other means
- *P* document published prior to the international filing date but later than the priority date claimed

- *T* later document published after the international filing date or priority date and not in conflict with the application but cited to understand the principle or theory underlying the invention
- *X* document of particular relevance; the claimed invention cannot be considered novel or cannot be considered to involve an inventive step when the document is taken alone
- *Y* document of particular relevance; the claimed invention cannot be considered to involve an inventive step when the document is combined with one or more other such documents, such combination being obvious to a person skilled in the art.
- *Z* document member of the same patent family

Date of the actual completion of the international search

10 June 2009

Date of mailing of the international search report

18/06/2009

Name and mailing address of the ISA/

European Patent Office, P.B. 5818 Patentlaan 2
NL - 2280 HV Rijswijk
Tel. (+31-70) 340-2040.
Fax: (+31-70) 340-3016

Authorized officer

Marrec, Patrick

INTERNATIONAL SEARCH REPORT

International application No

PCT/US2009/035792

C(Continuation). DOCUMENTS CONSIDERED TO BE RELEVANT

Category*	Citation of document, with indication, where appropriate, of the relevant passages	Relevant to claim No.
X	JP 59 192225 A (HITACHI LTD) 31 October 1984 (1984-10-31) figures 11(a),11(b),13(b) -----	1-20

INTERNATIONAL SEARCH REPORT

Information on patent family members

International application No

PCT/US2009/035792

Patent document cited in search report	A	Publication date	Patent family member(s)	Publication date
US 4354736	A	19-10-1982	AU 541953 B2	31-01-1985
			AU 7182181 A	24-12-1981
			CH 651674 A5	30-09-1985
			DE 3123607 A1	15-04-1982
GB 1503793	A	15-03-1978	AU 8010775 A	21-10-1976
			BE 828200 A1	18-08-1975
			CA 1051239 A1	27-03-1979
			CH 583911 A5	14-01-1977
			DE 2419786 A1	06-11-1975
			FR 2269088 A1	21-11-1975
			IT 1032678 B	20-06-1979
			JP 50149357 A	29-11-1975
			NL 7504415 A	28-10-1975
			SE 406816 B	26-02-1979
			SE 7504763 A	27-10-1975
EP 0801039	A	15-10-1997	DE 19614572 A1	16-10-1997
US 2992517	A	18-07-1961	BE 693179 A	03-07-1967
JP 59192225	A	31-10-1984	NONE	