



US 20020148382A1

(19) **United States**

(12) **Patent Application Publication**

Norton et al.

(10) **Pub. No.: US 2002/0148382 A1**

(43) **Pub. Date: Oct. 17, 2002**

(54) **PULTRUDED PANEL**

Related U.S. Application Data

(75) Inventors: **Allen E. Norton**, Arlington, TX (US);
Stephen W. Smith, Dallas, TX (US);
William A. Knapp, Dallas, TX (US);
Alex K. Hoover, Ft. Worth, TX (US);
Dustin L. Troutman, Hopewell, PA
(US)

(60) Provisional application No. 60/267,882, filed on Feb. 9, 2001.

Publication Classification

(51) **Int. Cl.⁷** **B61D 17/00**
(52) **U.S. Cl.** **105/396**

Correspondence Address:
Baker Botts L.L.P.
Suite 600
2001 Ross Avenue
Dallas, TX 75201-2980 (US)

(57) **ABSTRACT**
Pultruded panels having a first longitudinal edge profile and a second longitudinal edge profile may be used to form a floor assembly mounted on a railway car underframe. The pultruded panels may also be used to form walkways, bridges, piers and other structures. A bead may be placed on at least one of the longitudinal edge profiles to form a gap between an adjacent pultruded panel. An adhesive may be placed within the gap to couple or bond adjacent pultruded panels with each other. Void spaces may be formed within the pultruded panel and filled with foam to provide improved resistance to heat transfer through the respective panel. Respective coverings may be placed on opposite ends of each panel to block access to the associated void spaces.

(73) Assignee: **TRN Business Trust**

(21) Appl. No.: **10/071,165**

(22) Filed: **Feb. 8, 2002**

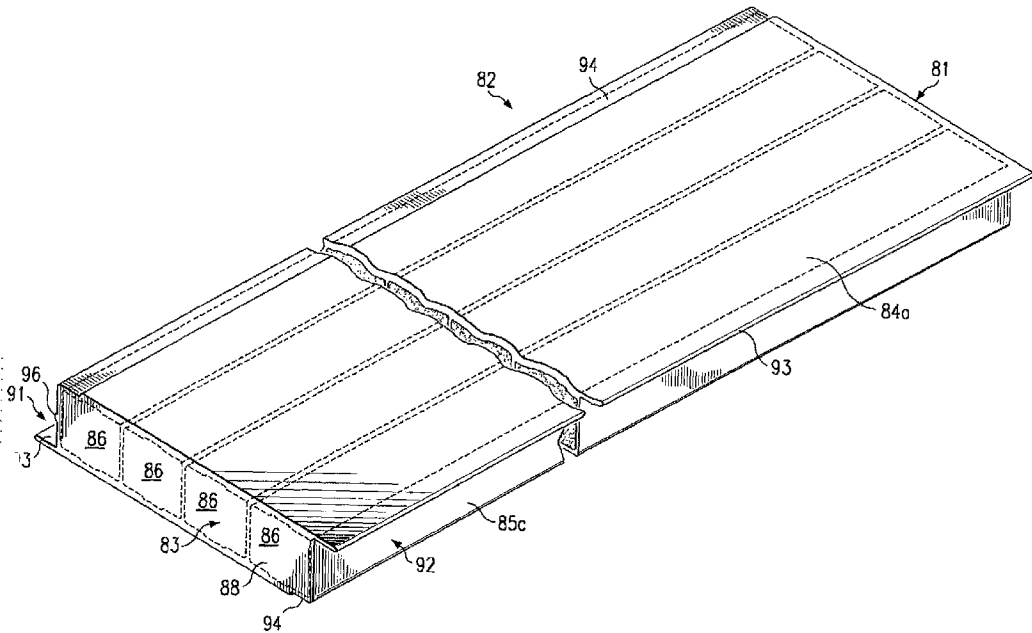

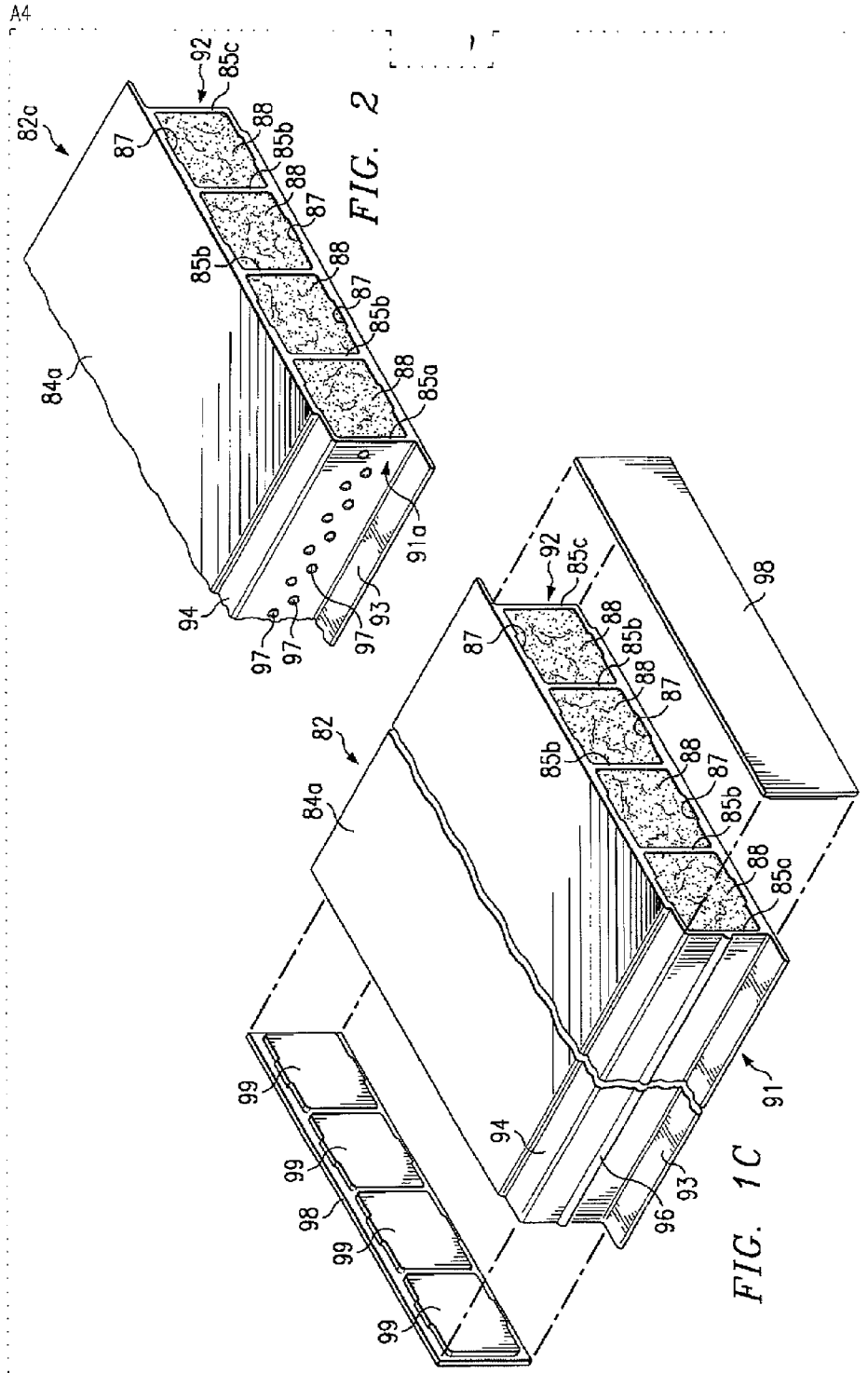

A4

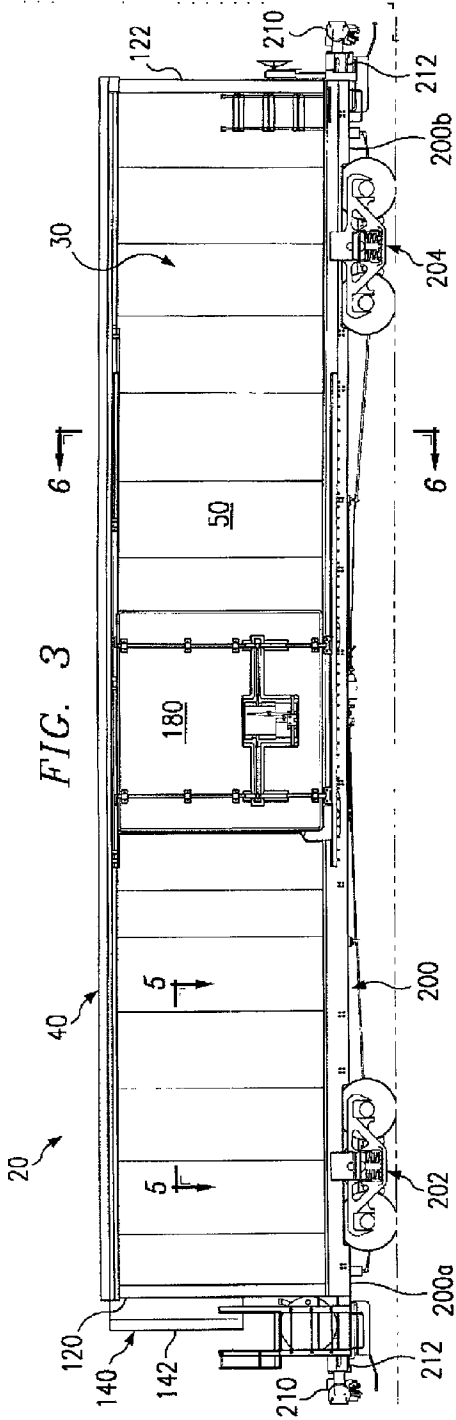

FIG. 3

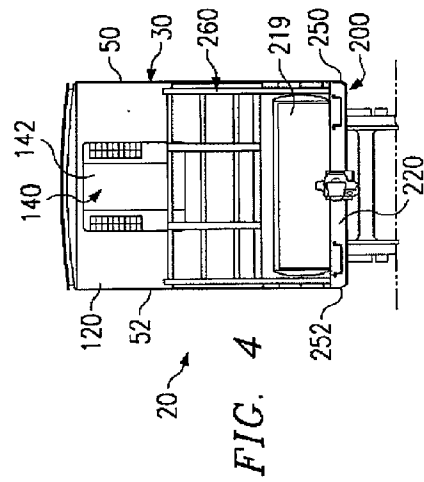

FIG. 4

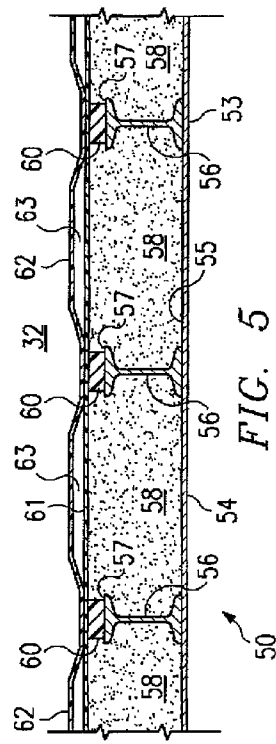
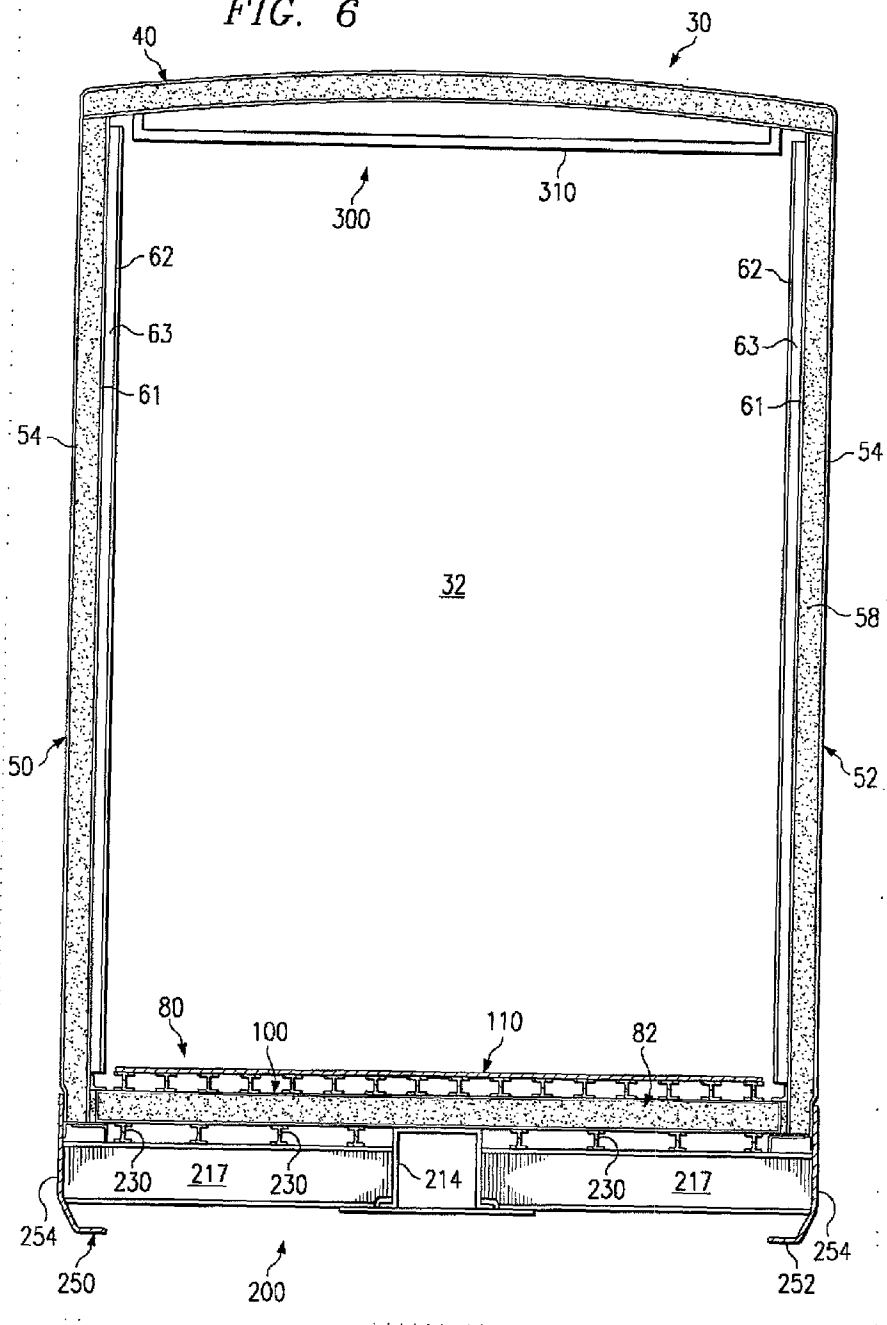

FIG. 5

A4

FIG. 6



A4

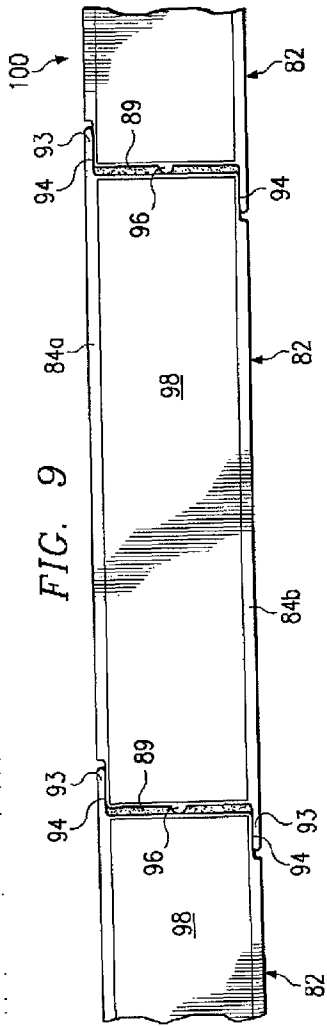

FIG. 9

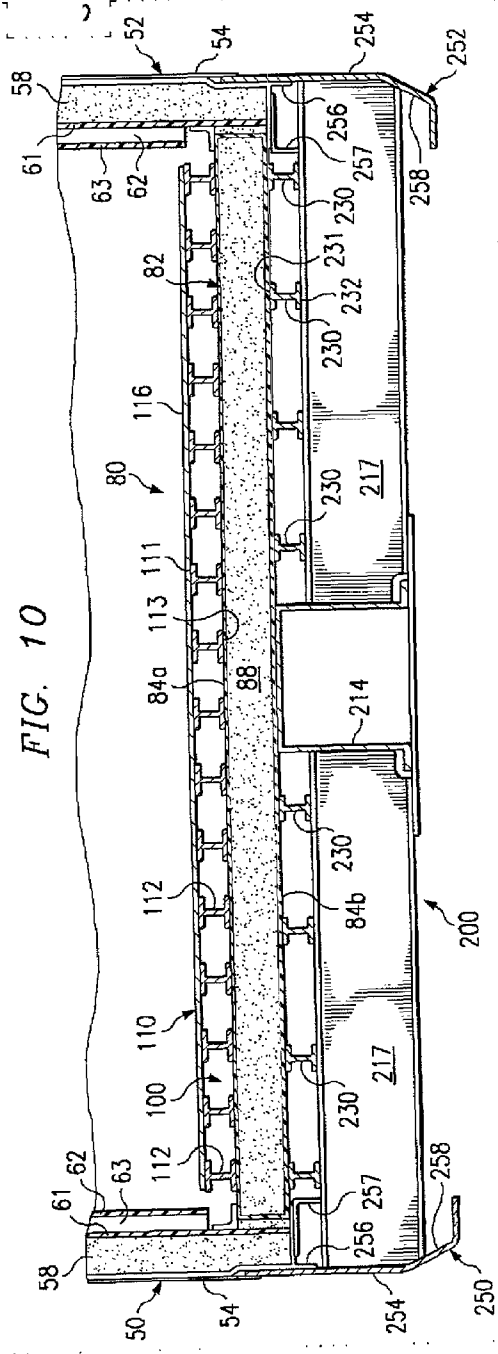
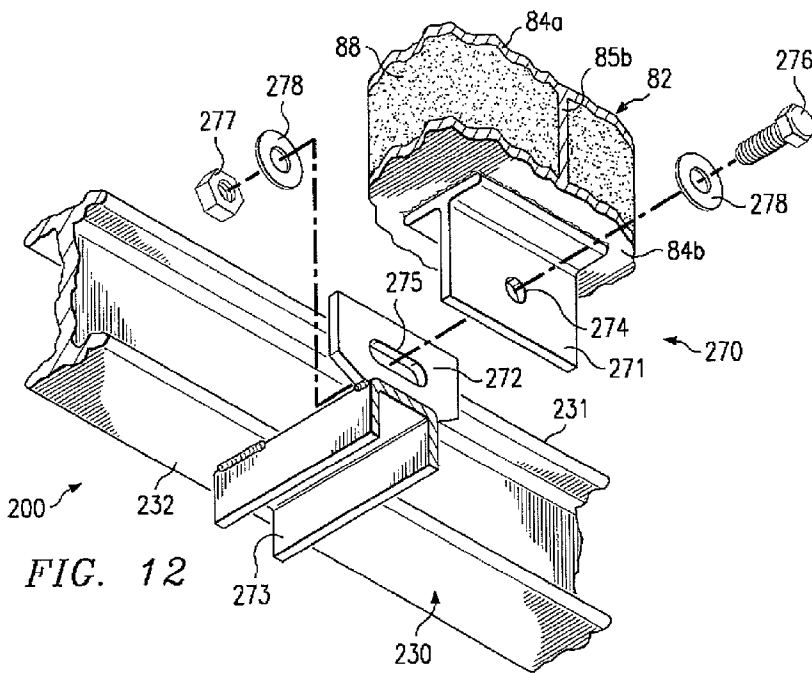
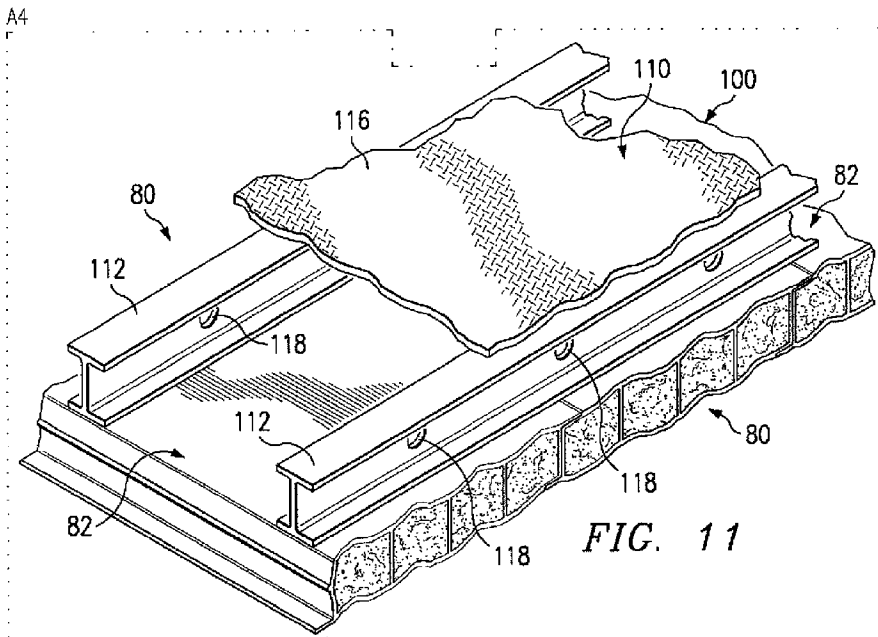

FIG. 10



A4

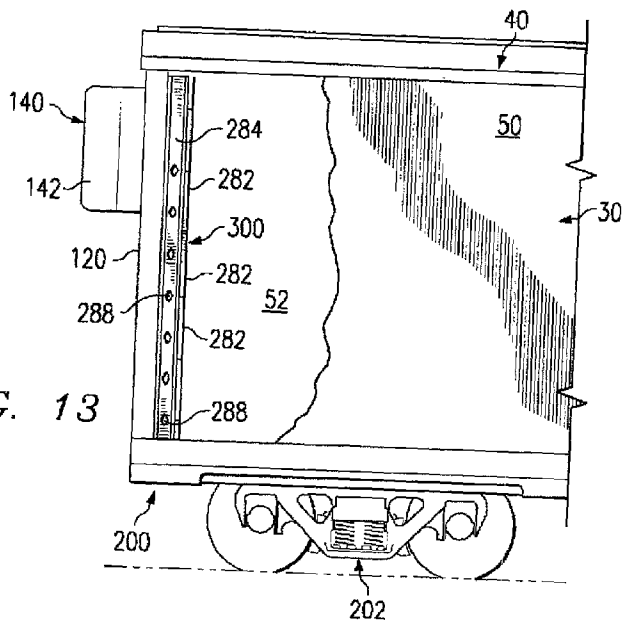

FIG. 13

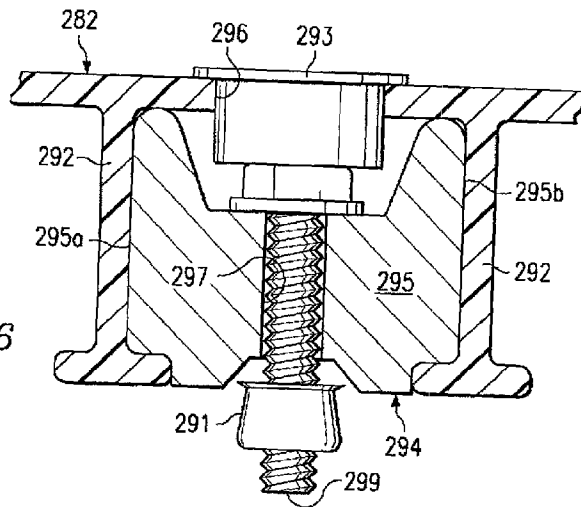

FIG. 16

PULTRUDED PANEL

RELATED APPLICATION

[0001] This application claims the benefit of provisional application entitled, "Temperature Controlled Railway Car", Serial No. 60/267,882 filed Feb. 9, 2001.

[0002] This application is related to copending patent application entitled, "Temperature Controlled Railway Car", Ser. No. _____, filed _____; copending patent application entitled, "Roof Assembly And Airflow Management System For Temperature Controlled Railway Car", Ser. No. _____, filed _____; and copending application entitled, "Manufacturing Facility and Method of Assembling A Railway Car", Ser. No. _____, filed _____ which claim priority from the same provisional application.

TECHNICAL FIELD

[0003] The present invention is related to pultruded panels which have multiple uses including forming portions of a floor assembly associated with a composite box structure mounted on a railway car underframe.

BACKGROUND OF THE INVENTION

[0004] Over the years, general purpose railway boxcars have progressed from relatively simple wooden structures mounted on flat cars to more elaborate arrangements including insulated walls and custom designed refrigeration equipment. Various types of insulated boxcars are presently manufactured and used. A typical insulated boxcar includes an enclosed structure mounted on a railway car underframe. The enclosed structure generally includes a floor assembly, a pair of side walls, a pair of end walls and a roof. The side walls, end walls and roof often have an outer shell, one or more layers of insulation and interior paneling.

[0005] The outer shell of many railway boxcars often has an exterior surface formed from various types of metal such as steel or aluminum. The interior paneling is often formed from wood and/or metal as desired for the specific application. For some applications the interior paneling has been formed from fiber reinforced plastic (FRP). Various types of sliding doors including plug type doors are generally provided on each side of conventional boxcars for loading and unloading freight. Conventional boxcars may be assembled from various pieces of wood, steel and/or sheets of composite materials such as fiberglass reinforced plastic. Significant amounts of raw material, labor and time are often required to complete the manufacture and assembly of conventional boxcars.

[0006] The underframe for many boxcars include a center sill with a pair of end sills and a pair of side sills arranged in a generally rectangular configuration corresponding approximately with dimensions for the floor of the boxcar. Cross bearers and cross ties are provided to establish desired rigidity and strength for the associated railway car underframe. A plurality of longitudinal stringers are also often provided on each side of the center sill to support the floor of a boxcar. Examples of such railway car underframes are shown in U.S. Pat. Nos. 2,783,718 and 3,266,441.

[0007] Traditionally, refrigerated boxcars often have less inside height than desired for many types of lading and a relatively short interior length. Heat transfer rates for con-

ventional insulated boxcars and refrigerated boxcars are often much greater than desired. Therefore, refrigeration systems associated with such boxcars must be relatively large to maintain desired temperatures while shipping perishable lading.

[0008] A wide variety of composite materials have been used to form railway cars and particular boxcars. U.S. Pat. No. 6,092,472 entitled "Composite Box Structure For A Railway Car" and U.S. Pat. No. 6,138,580 entitled "Temperature Controlled Composite Boxcar" show some examples. One example of a composite roof for a railway car is shown in U.S. Pat. No. 5,988,074 entitled "Composite Roof for a Railway Car".

SUMMARY OF THE INVENTION

[0009] In accordance with teachings of the present invention, several disadvantages and problems associated with insulated boxcars, refrigerated boxcars and other types of temperature controlled railway cars have been substantially reduced or eliminated. For one embodiment a floor assembly for a composite box structure may be formed from pultruded panels. The present invention may include a composite box structure with a temperature control system and an airflow management system satisfactory for use with a refrigerated boxcar or a temperature controlled railway car. A composite box structure formed in part with pultruded panels in accordance with teachings of the present invention provides enhanced insulation, increased load carrying capacity, better temperature regulation, increased service life, and reduced maintenance costs as compared to a typical refrigerated boxcar.

[0010] One aspect of the present includes a floor assembly having a primary floor and a secondary floor. The primary floor may be formed from pultruded panels. Void spaces associated with the pultruded panels may be filled with an insulating foam. The secondary floor may be formed by beams secured to one surface of the primary floor and metal plates or coverings attached to the beams opposite from the primary floor. The beams may have holes to allow air circulation therethrough.

[0011] Another aspect of the invention includes bonding selected portions of the floor assembly with adjacent portions of a railway car underframe using a biodegradable structural adhesive. Restraining anchor assemblies formed in accordance with teachings of the present invention allow other portions of the floor assembly to move longitudinally relative to the railway car underframe and restrict vertical movement relative to the railway car underframe.

[0012] One aspect of the present invention includes forming panels with a respective pair of longitudinal edge profiles. At least one projection may be formed on one of the longitudinal edge profiles of each panel to create a gap between the longitudinal edge profile of an adjacent panel. The gap may be sized to receive an adhesive to bond adjacent panels with each other. For one application the projection may be a bead formed on the longitudinal edge profile extending along substantially the full length of the panel. For other applications the bead may extend along only a portion of the longitudinal edge profile. Also, projections other than a bead may be satisfactorily used to form the desired gap between adjacent panels.

[0013] Technical benefits of the present invention include adhesively bonding or securely attaching selected portions of a floor assembly with a railway car underframe. Other portions of the floor assembly may be slidably coupled with the railway car underframe to allow limited contraction and expansion of the floor assembly relative to the railway car underframe.

[0014] Panels may be formed in accordance with teachings of the present invention using various types of commercially available pultrusion techniques. However, the present invention is not limited to pultruded panels. Also, panels formed in accordance with teachings of the present invention may be used with a wide variety of railway cars. However, the present invention is not limited to the railway car industry.

BRIEF DESCRIPTION OF THE DRAWINGS

[0015] For a more complete understanding of the present invention, and the advantages thereof, reference is now made to the following written description taken in conjunction with the accompanying drawings, in which:

[0016] FIG. 1A is a schematic drawing showing an isometric, exploded view with portions broken away of a panel formed in accordance with teachings of the present invention;

[0017] FIG. 1B is a schematic drawing showing an end view of the panel of FIG. 1A.

[0018] FIG. 1C is a schematic drawing showing another isometric view with portions broken away of the panel of FIG. 1A;

[0019] FIG. 2 is a schematic drawing showing an isometric view with portions broken away of another panel formed in accordance with teachings of the present invention;

[0020] FIG. 3 is a schematic drawing in elevation showing a side view of a temperature controlled railway car having a composite box structure with a temperature control system and an airflow management system;

[0021] FIG. 4 is an end view of the temperature controlled railway car of FIG. 3;

[0022] FIG. 5 is a schematic drawing in section with portions broken away showing a portion of a side wall assembly taken along lines 5-5 of FIG. 4;

[0023] FIG. 6 is a schematic drawing in section with portions broken away taken along lines 6-6 of FIG. 3;

[0024] FIG. 7 is a schematic drawing showing a plan view of a primary floor formed in accordance with teachings of the present invention;

[0025] FIG. 8 is a schematic drawing in section with portions broken away showing a pultruded panel with a drain opening formed therein incorporating teachings of the present invention;

[0026] FIG. 9 is a schematic drawing showing an end view with portions broken away of three panels bonded with each other in accordance with teachings of the present invention;

[0027] FIG. 10 is a schematic drawing in section with portions broken away showing a floor assembly mounted on a railway car underframe in accordance with teachings of the present invention;

[0028] FIG. 11 is a schematic drawing showing an isometric view with portions broken away of a floor assembly having a primary floor and a secondary floor formed in accordance with teachings of the present invention.

[0029] FIG. 12 is a schematic drawing showing an exploded view of a restraining anchor assembly disposed between portions of a floor assembly and portions of a railway car underframe in accordance with teachings of the present invention;

[0030] FIG. 13 is a schematic drawing showing a side view with portions broken away of a railway car having an interior bulkhead incorporating teachings of the present invention;

[0031] FIG. 14 is a schematic drawing showing an isometric view with portions broken away of the interior bulkhead shown in FIG. 13;

[0032] FIG. 15 is a schematic drawing showing an exploded isometric view of a pultruded panel and inserts satisfactory for use in forming an interior bulkhead in accordance with teachings of the present invention; and

[0033] FIG. 16 is an enlarged schematic drawing in section with portions broken away showing portions of a pultruded panel and an attachment insert in accordance with teachings of the present invention.

DETAILED DESCRIPTION OF THE INVENTION

[0034] Preferred embodiments of the invention and its advantages are best understood by reference to FIGS. 1A-16 of the drawings, like numerals for like and corresponding parts of the various drawings.

[0035] Various aspects of the present invention will be described with respect to forming a floor assembly and interior bulkheads associated with a railway car using pultruded panels. However, the present invention is not limited to panels formed using pultrusion technology (pultruded panels). Panels may be formed in accordance with teachings of the present invention by a wide variety of techniques including injection molding and extrusion technologies. Panels formed in accordance with teachings of the present invention may be satisfactorily used in a wide variety of applications including, but not limited to, commercial buildings, residential building, walkways, bridges, _____, _____, and _____ (not expressly shown).

[0036] U.S. Pat. No. 5,716,487 entitled "Pultrusion Apparatus" assigned to Creative Pultrusions, Inc. describes one example of equipment and procedures which may be used to form pultruded panels. Pultruded panels 82a, 82b, 82c and 282 may be formed from a wide variety of materials including fiber reinforced plastic, _____, _____ and _____.

[0037] Various aspects of the present invention will be described with respect to pultruded panels 82 and 282. Alternative embodiments of these panels have been designated 82a, 82b and 282a-d. See FIGS. 1A-C, 2, 8 and 15. For embodiments shown in this application, each pultruded panel 82 has a generally rectangular configuration defined in part by first end 81 and second end 83 with first longitudinal edge profile 91 and second longitudinal edge profile 92

extending between first end **81** and second end **83**. Longitudinal edge profiles **91** and **92** are spaced from each other.

[0038] For one application, each pultruded panel **82** may include first layer **84a** and second layer **84b** with a plurality of webs or dividers **85** disposed therebetween. Webs **85a** and **85c** form a portion of respective first longitudinal edge profile **91** and second longitudinal edge profile **92**. Webs **85b** may have substantially the same dimensions. For one embodiment, webs **85** disposed between first layer **84a** and second layer **84b** form void spaces or cavities **86**. Each void space **86** may be filled with insulating foam **88** (see FIG. 1C) having good thermal insulation characteristics. Insulating foam **88** substantially reduces heat transfer through floor assembly **80**. Various types of insulating foam such as _____ and _____ may be satisfactorily used to fill void spaces **86**.

[0039] For embodiments of the present invention as shown in FIGS. 1A-FIG. 2, a plurality of respective recesses **87** may be formed in first layer **84a** and second layer **84b** within each void space **86**. Each recess **87** preferably extends longitudinally from first end **81** to second end **83** of the associated pultruded panel **82**. Forming recesses **87** reduces overall weight of each pultruded panel **82**. As shown in FIGS. 1C and 2, recesses **87** formed in first layer **84a** and second layer **84b** cooperate with each other to define a typical I beam configuration for each web **85b**. As a result, pultruded panel **82** maintains desired rigidity and strength while at the same time having reduced weight which allows a corresponding increase in load carrying capacity of railway car **20**.

[0040] The configuration of longitudinal edge profiles **91** and **92** are preferably selected to engage respective longitudinal edge profiles **91** and **92** of adjacent pultruded panels **82**. See FIG. 9. Longitudinal edge profiles **91** and **92** may include respective flanges or lips **93** which extend laterally therefrom along approximately the full length of the associated pultruded panel **82**. Longitudinal edge profile **91** preferably includes respective recess **94** formed in first layer **84a**. Longitudinal edge profile **92** preferably includes respective recess **94** formed in second layer **84b**. The dimensions and configurations of flanges **93** are selected to be compatible with recesses **94** of adjacent pultruded panels **82**.

[0041] Pultruded panels **82** and **82a** have substantially the same configuration and dimensions except for projections formed on respective longitudinal edge profiles **91**. A projection such as bead **96** may be formed along longitudinal edge profile **91** of each pultruded panel **82**. When longitudinal edge profile **91** is engaged with an adjacent longitudinal edge profile **92**, bead **96** creates a gap therebetween to allow injection of an adhesive compound into the associated gap. The adhesive compound (not expressly shown) may be used to bond or couple adjacent pultruded panels **82** with each other. See FIG. 9. For some applications biodegradable adhesive compounds may be used to bond or couple pultruded panels **82** with each other.

[0042] Pultruded panels may be formed in accordance with teachings of the present invention with a wide variety of projections formed on longitudinal edge profiles **91** and/or **92**. For some applications more than one bead **96** may be formed on longitudinal edge profile **91**. For other applications breaks or discontinuities (not expressly shown) may

be formed in bead **96**. Pultruded panel **82a** as shown in FIG. 2 includes a plurality of buttons **97** formed on longitudinal edge profile **91a**. For some applications serrations and/or ribs (not expressly shown) may be formed as part of one or more longitudinal edge profiles to provide desired projections.

[0043] For the embodiment of the present invention as shown in FIGS. 1A-1C respective cover plates or end caps **98** may be placed over first end **81** and second end **83** to block access to associated void spaces **86**. Cover plates **98** prevent moisture or other contaminants from contacting insulating foam **88** and reducing its thermal insulating characteristics. Also, any moisture or liquids which enter void spaces **86** may cause an undesired increase in weight of the associated pultruded panel **82**. For some applications cover plates **98** may be formed with a generally rectangular configuration corresponding generally with dimensions of respective first end **81** and second end **83**. For some applications projections **99** may be formed on each cover plate **98** to engage respective void spaces **86**. For example cover plate **98**, as shown in FIG. 1C, includes projections **99** with a profile corresponding with the profile of respective void spaces **86**.

[0044] Cover plates **98** may be formed from fiber reinforced plastic material or any other material compatible with materials used to form the associated pultruded panel **82**. Various types of coverings may be placed over the end of panels formed in accordance with teachings of the present invention. The present invention is not limited to the use of cover plates or end caps **98** as shown in FIGS. 1A-1C.

[0045] Temperature controlled railway car **20** incorporating teachings of the present invention is shown in FIGS. 3, 4, 6, 10, and 13 with composite box structure **30** mounted on railway car underframe **200**. As discussed later in more detail, temperature controlled railway car **20** preferably includes temperature control system **140** and airflow management system **300**.

[0046] For embodiments of the present invention as shown in FIGS. 3 and 4, temperature controlled railway car **20** may have exterior dimensions which satisfy requirements of Plate F and associated structural design requirements of the Association of American Railroads (AAR). Forming various components of composite box structure **30** in accordance with teachings of the present invention and assembling such components on railway car underframe **200** results in reducing the weight of temperature controlled railway car **20** and increasing both internal volume and load carrying capacity as compared to many conventional refrigerated boxcars satisfying Plate F requirements. A composite box structure and associated insulated boxcar or temperature controlled railway car may be formed in accordance with teachings of the present invention to accommodate various geometric configurations and load carrying requirements to meet specific customer needs concerning size and temperature specifications for different types of lading.

[0047] The term "composite box structure" refers to a generally elongated structure having a roof assembly, a floor assembly, a pair of side wall assemblies, and a pair of end wall assemblies which cooperate with each other to provide a generally hollow interior satisfactory for carrying different types of lading associated with insulated boxcars and refrigerated boxcars. Portions of the roof assembly, floor assem-

bly, side wall assemblies and/or end wall assemblies may be formed from conventional materials such as steel alloys and other metal alloys used to manufacture railway cars. Portions of the roof assembly, floor assembly, side wall assemblies and/or end wall assemblies may also be formed from composite materials such as advanced thermal plastics, insulating foam, fiberglass pultrusions and ballistic resistant fabrics. Examples of some of the materials used to form a composite box structure in accordance with teachings of the present invention will be discussed throughout this application.

[0048] Composite box structure **30** may be formed from several major components including roof assembly **40**, side wall assemblies **50** and **52**, floor assembly **80** and end wall assemblies **120** and **122**. Major components associated with composite box structure **30** may be fabricated individually and then attached to or assembled on railway car underframe **200** to form temperature controlled railway car **20**. Individually manufacturing or fabricating major components of composite box structure **30** allows optimum use of conventional railcar manufacturing techniques. For example, side stakes and door posts may be welded with top chords and bottom chords using conventional railcar manufacturing techniques to provide structural members for a side wall assembly.

[0049] Manufacturing procedures associated with thermoplastic materials and foam insulation may be used to form other portions of composite box structure **30**. For example, pultruded panels **82** filled with insulating foam may be used to form portions of floor assembly **80** with substantially improved heat transfer characteristics as compared with conventional refrigerated boxcar floor assemblies. Other portions of floor assembly **80** may be formed using metal I beams and metal deck or floor plates.

[0050] For embodiments of the present invention as shown in FIGS. 3, 4, 6, 10, and 12 portions of railway car underframe **200** may be manufactured and assembled using conventional railcar manufacturing procedures and techniques. Railway car underframe **200** preferably includes a pair of railway car trucks **202** and **204** located proximate each end of railway car underframe **200**. Standard railcar couplings **210** may also be provided at each end of railway car underframe **200**. Each coupling **210** preferably includes end of car cushioning unit **212** disposed at each end of center sill **214**. Railway car underframe **200** preferably includes a plurality of longitudinal stringers **230**. FIGS. 6, 10 and 12 show portions of floor assembly **80** disposed on longitudinal stringers **230**.

[0051] Railway car underframe **200** also includes side sill assemblies **250** and **252** and end sill assemblies **220** and **222**. Side wall assemblies **50** and **52** may be fabricated with respective side sill assemblies **250** and **252** formed as an integral component thereof. End wall assemblies **120** and **122** may also be fabricated with at least portions of respective end sill assemblies **220** and **222** formed as an integral component thereof.

[0052] Side sills **250** and **252** as shown in FIGS. 6 and 10 have a generally J shaped cross section. The configuration of respective exterior surfaces **254** formed on side sills **250** and **252** preferably corresponds with the dimensions of plate F. Respective longitudinal supporting members **256** are preferably attached to interior surface **258** of each side sill **250**

and **252**. Respective longitudinal supporting members **257** may also be disposed between each longitudinal supporting member **256** and cross bearers **216**. For the embodiment of the present invention as shown in FIGS. 6 and 10 longitudinal supporting members **256** and **257** may be formed by conventional metal angles having desired dimensions compatible with railway car underframe **100** and floor assembly **80**. Longitudinal supporting members **256** and **257** provide support for primary floor **100**.

[0053] Side wall assemblies **50** and **52** have substantially the same configuration and overall design. Therefore, various features of composite box structure **30** will be discussed primarily with respect to side wall assembly **50**, a portion of which is shown in FIG. 5.

[0054] Side wall assembly **50** preferably includes a plurality of metal side sheets **54** disposed on the exterior of composite box structure **30**. A plurality of side stakes or support post **56** may be attached to interior surface **55** of each side sheet **54**. Support posts **56** project toward interior **32** of composite box structure **30**. For some applications, isolator **60** formed from a thermoplastic polymer such as polyvinyl chloride (PVC) insulating material may be attached to interior surface **57** of each support post **56**. For other applications alternating blocks of PVC and blocks of insulating foam may be disposed on interior surface **57** of support **56**. Various thermoplastic polymers, urethane foams and other types of insulating material may be attached to first surface **57** of each support post **56** to form isolators **60**. The present invention is not limited to the use of PVC strips.

[0055] First layer **61** of polymeric material may then be attached to isolators **60**. Foam insulation **58** may be disposed between adjacent support posts **56** and bonded with the interior surface **55** of side sheets **54**, the interior surface of first layer **61** and adjacent portions of support posts **56**. For some applications a layer of scrim (not expressly shown) may be attached to the interior surface of first layer **61** to enhance bonding with foam insulation **58**. Second layer **62** of polymeric material may be attached to first layer **61**.

[0056] First layer **61** and second layer **62** are preferably formed from tough, light weight, generally rigid material having high impact resistance. First layer **61** and second layer **62** cooperate with each other to form a liner for composite box structure **30**. For some applications first layer **61** and second layer **62** are preferably formed from Bulitex material available from U.S. Liner Company, a division of American Made, Inc. Bulitex material may be generally described as a ballistic grade composite scuff and wall liner.

[0057] Various types of ballistic resistant fabric may be satisfactorily used to provide a liner for composite box structure **30**. Ballistic resistant fabrics are often formed with multiple layers of woven or knitted fibers. The fibers are preferably impregnated with low modulus elastomeric material as compared to the fibers which preferably have a high modulus. U.S. Pat. No. 5,677,029 entitled "Ballistic Resistant Fabric Articles" and assigned to Allied Signal shows one example of a ballistic resistant fabric.

[0058] Second layer **62** preferably has a corrugated cross section which provides desired airflow paths **63** when lading is disposed adjacent to the side wall assembly **50**. The corrugated cross section of second layer **62** provides airflow paths **63** which form portions of airflow management system **300**.

[0059] For one application side sheets **54** may be formed from twelve (12) gauge steel. Support posts **56** may be three (3) inch I beams. Isolators **60** may have dimensions of approximately two (2) inches by two (2) inches by three fourths ($\frac{3}{4}$) of an inch. Foam insulation **58** may have a thickness of approximately four (4) inches. First layer **61** may be formed from Bulitex material having a thickness of approximately 0.04 inches. Second layer **62** may be formed from Bulitex material having a thickness of approximately 0.06 inches. The width of each corrugation formed in second layer **62** may be between approximately four (4) and five (5) inches. The corrugations may form airflow gaps **63** of approximately one half ($\frac{1}{2}$) inch relative to first layer **61**.

[0060] End wall assemblies **120** and **122** may be formed using similar materials and techniques as described with respect to side wall assembly **50**. In side wall assembly **50** support posts **56** extend generally vertically from side sill **254** to an associated top chord (not expressly shown). End wall assemblies **120** and **122** may also be formed with I beams (not expressly shown) having a configuration similar to support posts **56**. However, respective I beams disposed within each end wall assembly **120** and **122** preferably extend generally horizontally with respect to each other and railway car underframe **200**. Such I beams may be referred to as "end beams". Also, end wall assemblies **120** and **122** may be formed with only one layer of polymeric material as compared with first layer **61** and second layer **62** associated with side wall assembly **50**.

[0061] Railway car underframe **200** may include center sill **214**, a plurality of longitudinal stringers **230** and cross ties **216**, cross bearers and body bolsters arranged in a generally rectangular configuration. The associated cross bearers and body bolsters are not expressly shown. Cross ties **216** are typically attached to and extend laterally from center sill **214**. Longitudinal stringers **230** may be disposed on cross ties **216** and extend parallel with center sill **214**. Longitudinal stringers **230** are spaced laterally from each other between center sill **214** and respective ends of cross ties **216**. The number of cross ties **216** and longitudinal stringers **230** may be varied depending on the desired load carrying characteristics for the resulting railway car **20**. Each longitudinal stringer **230** preferably includes first surface **231** and second surface **232** which rests on associate cross ties **216**.

[0062] After side wall assemblies **50** and **52** and end wall assemblies **120** and **122** have been attached to railway car underframe **200**, portions of floor assembly **80** are preferably installed within composite box structure **30**. For some applications a plurality of pultruded panels **82** are preferably bonded with each other to form primary floor **100** having a generally rectangular configuration corresponding generally with the desired interior length and width of composite box structure **30**. The length of each pultruded panel **82** preferably corresponds with the desired interior width of composite box structure **30**. The number of pultruded panels **82** used to form primary floor **100** is approximately equal to the desired interior length of composite box structure **30** divided by the width of each pultruded panel **82**. For the embodiment shown in FIGS. 7 and 8 one or more pultruded panels **82b** may have a narrower width than pultruded panels **82** to form primary floor **100** with the desired overall length. Pultruded panels **82b** may include one or more drain openings. See FIG. 8.

[0063] After the desired number of pultruded panels **82** have been bonded with each other, the resulting primary floor **100** may be lowered through side wall assemblies **50** and **52** and end wall assemblies **120** and **122** until primary floor **100** engages first surface **231** of longitudinal stringers **230** and portions of side sills **250** and **252** and associated end sills (not expressly shown). For example, FIGS. 6 and 10 show portions of primary floor **100** resting on angle **256** attached with interior surface **258** of side sill **250**. Second angle **257** may also be disposed between angle **256** and cross tie **216** to provide additional support for both primary floor **100** and associated side wall assembly **50**.

[0064] Various techniques and procedures may be used to attach or couple primary floor **100** with longitudinal stringers **230** and/or side sills **250** and **252** and end sills **220** and **222**. For some applications only a selected portion of primary floor **100** represented by dotted lines **102** in FIG. 7 may be adhesively bonded or securely attached with adjacent portions of first surfaces **231** of longitudinal stringers **230**. Other portions of primary floor **100**, which are not attached to longitudinal stringers **230**, may expand and contract relative to railway car underframe **200** as temperature changes within composite box structure **30**.

[0065] Pultruded panels **82**, disposed over the middle portion of railway car underframe **200**, are preferably bonded with adjacent first surfaces **231** of longitudinal stringers **230**. Other portions of primary floor **100** may move longitudinally relative to longitudinal stringers **230** as the temperature within composite box structure **30** changes. FIG. 12 shows one example of a restraining anchor assembly which may be formed between portions of primary floor **100** and portions of selected longitudinal stringers **230** near opposite ends of railway car underframe **200**.

[0066] Pultruded panel **82b** may include one or more drain openings **104** with drain plug assembly **106** disposed therein. Various types of commercially available drain plugs may be disposed within each drain opening **104**. Drain plug assemblies **106** may be opened to allow cleaning the interior of composite box structure **30**. For some applications, floor assembly **80** preferably includes primary floor **100** and secondary floor **110**. FIG. 7 shows a top view of primary floor **100** formed in accordance with teachings of the present invention from a plurality of pultruded panels **82**. FIG. 9 shows an end view of pultruded panels **82** bonded or coupled with each other to form a portion of primary floor **100**. FIGS. 6, 10 and 11 show portions of secondary floor **110** disposed on primary floor **100** opposite from railway car underframe **200**.

[0067] As shown in FIGS. 6, 10 and 11 secondary floor **110** may be formed by placing a plurality of support beams **112** on pultruded panels **82** opposite from railway car underframe **200**. Each support beam **112** may have a configuration or cross section corresponding with a typical I beam. A plurality of deck plates or coverings **116** may be disposed on first surface **111** of each support beam **112**. For some applications second surface **113** of each support beam **112** may be adhesively bonded or coupled with portions of first layer **84a** of adjacent pultruded panel **82**. Deck plates or coverings **116** may be adhesively bonded or coupled with first surface **111** of each support beam **112**. Alternatively, all or portions of deck plates **116** may be mechanically fastened with support beams **112** using various types of mechanical

fasteners such as bolts, rivets, and/or HUCK fasteners (not expressly shown). For some applications support beams 112 and deck plates 116 may be formed from metal alloys or other materials typically associated with forming a floor.

[0068] As best shown in FIG. 11, a plurality of openings 118 may be formed in each support beam 112. Openings 111 allow for airflow or air circulation between primary floor 100 and secondary floor 110.

[0069] Floor assembly 80 is preferably formed with pultruded panels 82 extending generally perpendicular or normal to center sill 214 and longitudinal stringers 230. Support beams 112 are preferably disposed on pultruded panels 82 spaced from each other and extending generally perpendicular or normal to pultruded panels 82. Attaching deck plates or coverings 116 with support beams 112 provides further support and rigidity for the resulting floor assembly 80.

[0070] For the embodiment of the present invention as represented by railway car 20, floor assembly 80 preferably includes first end 80a disposed adjacent to first end 200a of railway car underframe 200 and second end 80b disposed adjacent to second end 200b of railway car underframe 200. A central portion of floor assembly 80 corresponding generally with dotted line portion 102 as shown in FIG. 7 may be adhesively bonded with adjacent portions of railway car underframe 200. At least one restraining anchor assembly 270 will be coupled with floor assembly 80 and adjacent portions of railway car underframe 200 proximate first end 200a. At least a second restraining anchor assembly 270 will be coupled with floor assembly 80 and adjacent portions of railway car underframe proximate second end 200b. For some applications a pair of restraining anchor assemblies 270 will be provided at each end of railway car underframe 200.

[0071] Restraining anchor assembly 270 preferably includes first member 271 securely bonded with or attached to second layer 84b of an adjacent pultruded panel 82. Various types of adhesives may be used to bond first member 271 with second layer 84b. Second member 272 is preferably securely engaged with adjacent portions of railway car underframe 200. For the embodiment of the present invention as shown in FIG. 12, channel 273 having a generally C-shaped configuration is preferably welded to or otherwise securely attached to adjacent portions of longitudinal stringers 230. Second member 272 may in turn be welded to or otherwise securely attached with channel 273 adjacent to first member 271. For the embodiment of the present invention as shown in FIG. 12, slot 274 is formed in first member 271 and opening or bolt hole 275 is formed in second member 272. For other applications slot 274 may be formed in second member 272 and bolt hole 275 formed in first member 271.

[0072] Various types of mechanical fasteners may be used to slidably attach first member 271 with second member 275. For the embodiment of the present invention as shown in FIG. 12, bolt 276 may be inserted through slot 274 and bolt hole 275. Nut 277 may then attached with bolt 276. Slot 274 and bolt 276 cooperate with each other to allow limited longitudinal movement or sliding of first member 271 relative to second member 272 during expansion and/or contraction of floor assembly 80 relative to railway car underframe 200. Bolt 276 and slot 274 cooperate with each other to limit any vertical movement of floor assembly 80 relative

to railway car underframe 200 during expansion and contraction of floor assembly 80 relative to railway car underframe 200.

[0073] For the embodiment of the present invention as shown in FIGS. 6, 10 and 11, secondary floor 110 may be formed using conventional, metal I beams and conventional deck plating or floor coverings. However, for some applications secondary floor 110 may be formed from a plurality of pultruded panels having a cross section similar to pultruded panel 282 as shown in FIG. 15. For still other applications secondary floor 110 may be formed from pultruded panels having a configuration similar to pultruded panels 82. The alternating configuration of longitudinal stringers, primary floor panel and secondary floor components provide a generally strong, rigid structure with opportunities for cost savings and weight reduction from increased use of composite and thermoplastic materials.

[0074] Temperature control system 140 preferably includes refrigeration unit or cooling unit 142 and airflow management system 300 which provides uniform, constant airflow around and through lading carried within composite box structure 30. For some applications such as transporting products in sub-zero, winter environments temperature control system 140 may include a heater (not expressly shown). Refrigeration unit 142 may be a self-contained refrigeration unit including a condenser (not expressly shown), airflow blowers (not expressly shown), external fuel tank 219 and a diesel engine (not expressly shown). For some applications, refrigeration unit 142 may provide airflow in the range of 3200 CFM. Self-contained refrigeration unit 142 provides the advantage of easier and faster maintenance as compared to conventional refrigerated boxcars with similar performance characteristics. As a result, temperature control system 140 generally lowers maintenance time and costs and increases the amount of time that temperature controlled railway car 20 remains in service between repairs. Various types of refrigeration systems are commercially available from companies such as Thermo King, Carrier and Dring. Such units are frequently used in motor carrier trailers and other large containers.

[0075] As shown in FIGS. 3 and 4, refrigeration unit 142 may be mounted on end wall assembly 120 of the composite box structure 30. End platform system 216 may be coupled to railway car underframe 200 near refrigeration unit 142 to provide easy access to refrigeration unit 142. Refrigeration unit 142 may include external fuel tank 219 located proximate to refrigeration unit 142. This provides the benefit of convenient access to both fuel tank 219 and refrigeration unit 142.

[0076] Airflow management system 300 provides a relatively uniform distribution of air at a desired temperature throughout the length, width and height of interior 32 of composite box structure 30. Airflow management system 300 allows cooled air to circulate from refrigeration unit 142, around and through products or lading contained within composite box structure 30, and back to refrigeration unit 142 or out of composite box structure 30. Airflow management system 300 may also be capable of circulating fresh air from outside composite box structure 30 or heated air throughout the interior portion of composite box structure 30.

[0077] Airflow management system 300 preferably includes a number of features which keep products shipped

within composite box structure **30** spaced from the interior surfaces of the side wall assemblies **50** and **52**, end wall assemblies **120** and **122**, and floor assembly **80** to create openings or gaps for airflow around the product. These features include ceiling plenum system **310**, secondary floor **110**, interior bulkhead or end barrier **280**, and side wall corrugations formed by second layer **62**. Some features of airflow management system **300** may slightly reduce volumetric carrying capacity of composite box structure **30**, but allow airflow around and through products shipped inside composite box structure **30** to achieve desired temperature regulation of such products.

[0078] Interior bulkhead or end barrier **280** may be formed within composite box structure **30** adjacent to end wall assembly **120**. For the embodiment of the present invention as shown in FIGS. 13-16, interior bulkhead **280** may be formed by attaching a plurality of support beams **284** and a plurality of pultruded panels **282** with each other in accordance with teachings of the present invention. Various types of supporting structures other than support beams **284** may be used to attach pultruded panels **282** with adjacent portions of an end wall assembly.

[0079] For one application, support beams **284** may have a cross section corresponding with a conventional I beam. Each support beam **284** preferably includes a respective web **285** with first flange **286** and second flange **287** attached thereto. First flange **286** of each support beam **284** may be securely attached with adjacent portions of wall assembly **120**. A plurality of openings **288** may be formed in each web **285** to allow circulation of airflow therethrough. For some applications openings **288** may have a generally football shaped configuration. Pultruded panels **282** may be attached to or mounted on second flange **287** using various techniques such as adhesive bonding or mechanical fasteners. For the embodiment of the present invention as shown in FIGS. 14, 15 and 16 a plurality of openings **298** may be formed in second flange **287** of selected support beams **284** to receive a mechanical fastener.

[0080] Pultruded panel **282** may include a plurality of slots **290** formed therein by respective web members **292**. A plurality of attaching inserts **292** are preferably disposed within one or more slots **290** for use in mechanically attaching each pultruded panel **282** with associated support beams **284**. For embodiments of the present invention as shown in FIGS. 14, 15 and 16, four attaching inserts **292** may be used to mount each pultruded panel **282** with associated support beams **284**. However the number of attaching inserts **294** may be varied depending upon the size of the associated pultruding panel. For example, see pultruded panel **282d** as shown in FIG. 14.

[0081] Each attaching insert **294** preferably includes a respective insert body **295** having a pair of opposite exterior surfaces **295a** and **295b** sized to be received within a respective slot **290**. For some applications insert body **295** may be an aluminum extrusion formed from an aluminum alloy. First opening **296** is preferably formed in and extends through insert body **295**. A second opening **297** is preferably formed in pultruded panel **282** at each desired location for a respective attaching insert **284**. A third opening **298** may be formed in portions of the supporting structure such as second flange **287** at each desired location for attaching an associated pultruded panel **282**. Bolt **299** may be disposed in

and extend through first opening **296**, second opening **297** and third opening **298**. A respective nut **291** may be attached to bolt **299**. Also, second opening **297** may be sized to allow inserting cover **293** therein. Various types of bolts, nuts and other mechanical fasteners may be satisfactorily used to attach pultruded panels **282** with a supporting structure formed in accordance with teachings of the present invention.

[0082] For the embodiment of the present invention as shown in FIG. 14, interior bulkhead **280** may be formed from pultruded panels **282** having various dimensions and configurations. Also, opening **146** may be provided within interior bulkhead **280** to provide access to refrigeration unit **142**. For this embodiment the length of support beams **284a** is substantially less than support beams **284**. The difference in length corresponds with desired dimensions for opening **146**. Also, pultruded panel **282c** is preferably hinged with a portion of interior bulkhead **280** adjacent to opening **146**. The different sizes and configuration of pultruded panels used to form interior bulkhead **280** include pultruded panels **282**, **282a**, **282b**, **282c**, and **282d**. For some applications, a thin sheet of fiber reinforced plastic (not expressly shown) may be placed over the interior surface of pultruded panels **282** to prevent airflow from going into each slot **290**. The thin sheet of fiber reinforcement plastic may be formed from various types of composite and/or plastic materials such as Lexan® to provide desired airflow characteristics between interior bulkhead **280** and adjacent portions of end wall assembly **120**.

[0083] For the embodiment of the present invention represented by interior bulkhead **280**, slots **290** of pultruded panels **282** extend generally horizontal relative to adjacent portions of end wall assembly **120**. For some applications pultruded panels **282** may be mounted on an interior surface of end wall assembly **122** with slots **290** disposed generally vertical relative to end wall assembly **122**. Air plenum **310** may then be coupled with adjacent portions of pultruded panels **282** (not expressly shown) to direct airflow from air plenum **310** into slots **290** and downwardly through slots **290** to floor assembly **80**.

[0084] One temperature controlled railway car formed in accordance with teachings of the present invention has the following features:

[0085] 286,000 lb. Gross Rail Load

[0086] Standard car equipped with 10'-0" wide by 11'-3½" high insulated single plug door 15" end-of-car cushioning unit

[0087] Meets AAR Plate "F" Clearance Diagram

[0088] State-of-the art temperature control unit, exterior service platform and interior access door

[0089] Satellite monitoring and control system

[0090] An airflow management system installed in the interior of the composite box structure

[0091] High performance insulating materials

[0092] Durable, wood free interior materials

[0093] No ferrous metals in the interior

Length Inside	72'-2"
Length Over Coupler Pulling Faces	82'-2"
Length over Strikers	77'-10"
Length Between Truck Centers	52'-0"
Truck Wheel Base	5'-10"
Width, Extreme	10'-6 5/8"
Width, Inside	9'-2"
Height, Extreme	16"-11 7/8"
Height Inside at Center Line of Car	12'-1 1/2"
Estimated Lightweight	105,000 lbs.
Estimated Load Limit- Based on 286,000 lbs. Gross Rail Load	181,000 lbs.
Gross Rail Load	286,000 lbs.
Cubic Capacity (Between bulkheads)	8,012 cubic feet
Cubic Capacity (Level with height of sides)	7,883 cubic feet

[0094] Although the present invention and its advantages have been described in detail, it should be understood that various changes, substitutions and alternations can be made herein without departing from the spirit and scope of the invention as defined by the following claims.

What is claimed is:

1. A floor assembly mounted on a railway car underframe comprising;

a plurality of panels with each panel having a first longitudinal edge profile and a second longitudinal edge profile;

each first longitudinal edge profile defined in part by a first lip extending laterally from the respective panel and a first recess formed in the respective panel;

each second longitudinal edge profile defined in part by a second lip extending laterally from the respective panel and a second recess formed in the respective panel;

the first recess of each first longitudinal edge profile sized to receive the second lip of an adjacent panel;

the second recess of each second longitudinal edge profile sized to receive the first lip of an adjacent panel;

the first longitudinal edge profile of each panel coupled with the second longitudinal edge profile of an adjacent panel;

a respective projection formed on one of the longitudinal edge profiles of each panel to create a gap between a longitudinal edge profile of an adjacent panel;

an adhesive disposed within each gap to bond the first longitudinal edge profile of one panel with the second longitudinal edge profile of an adjacent panel; and

the panels disposed on and secured to the railway car underframe.

2. The floor assembly of claim 1 wherein each panel further comprises:

a pultrusion having a plurality of void spaces formed therein; and

the void spaces filled with an insulating foam.

3. The floor assembly of claim 1 further comprising a plurality of support beams disposed on the panels opposite from the railway car underframe.

4. The floor assembly of claim 3 further comprising a covering disposed on the support beams opposite from the panels.

5. The floor assembly of claim 3 further comprising a plurality of openings formed in at least one of the support beam to allow circulation of air therethrough.

6. The floor assembly of claim 3 wherein at least one of the support beam comprises a generally I shaped cross section.

7. The floor assembly of claim 1 further comprising at least one of the panels having a drain opening extending therethrough and a drain plug releasably secured within the opening.

8. The floor assembly of claim 1 further comprising:

a first end located proximate a first end of the railway car underframe;

a second end located proximate a second end of the railway car underframe;

a central portion of the floor assembly disposed between the first end and the second end of the railway car underframe;

the central portion of the floor assembly adhesively bonded with adjacent portions of the railway car underframe;

at least one restraining anchor coupled with the floor assembly and the railway car underframe proximate the first end thereof; and

at least a second restraining anchor coupled with the floor assembly and the railway car underframe proximate the second end thereof.

9. The floor assembly of claim 8 wherein each restraining anchor further comprises:

a first member securely coupled with one of the pultruded panels;

a second member securely coupled with adjacent portions of the railway car underframe;

at least one of the first and second members having a slot formed therein; and

a bolt extending through the first member, the slot and the second member to allow limited longitudinal movement of the first member relative to the second member to limit any vertical movement during thermal expansion and contraction of the floor assembly relative to the railway car underframe.

10. A floor assembly mounted on a plurality of longitudinal stringers of a railway car underframe comprising:

the floor assembly and the railway car underframe each having a generally rectangular configuration with approximately the same dimensions;

a plurality of pultruded panels with each pultruded panel having a generally elongated rectangular configuration;

a plurality of void spaces formed within each pultruded panel;

- the void spaces extending longitudinally from respective openings in a first end of each pultruded panel to respective openings in a second end of each pultruded panel;
- each void space filled with an insulating foam;
- each pultruded panel having a first longitudinal edge profile and a second longitudinal edge profile spaced from each other and extending between the first end and the second end of the respective panel;
- an adhesive disposed between the first longitudinal edge profile of one pultruded panel and the second longitudinal edge profile of an adjacent pultruded panel to couple adjacent pultruded panels with each other;
- respective cover plates placed on the first end and the second end of each pultruded panel to block access to the void spaces; and
- the pultruded panels disposed on a first surface of the longitudinal stringers.
- 11.** The floor assembly of claim 10 further comprising:
- a respective bead formed along one of the longitudinal edge profiles of each pultruded panel to create a small gap between the one longitudinal edge profile and the longitudinal edge profile of an adjacent pultruded panel; and
- the gap sized to receive the adhesive to couple the adjacent pultruded panels with each other.
- 12.** The floor assembly of claim 10 further comprising:
- a plurality of support beams disposed on the pultruded panels opposite from the longitudinal stringers;
- the support beams oriented in a direction approximately normal to the pultruded panels;
- a plurality of openings formed in the support beams to allow circulation of air therethrough; and
- a covering disposed on the support beams opposite from the pultruded panels.
- 13.** The floor assembly of claim 10 wherein the adhesive further comprises biodegradable material.
- 14.** The floor assembly of claim 10 further comprising:
- the railway car underframe and the floor assembly having approximately the same width; and
- each pultruded panel having a length approximately equal to the width of the floor assembly.
- 15.** A pultruded panel comprising:
- a generally rectangular configuration defined in part by a first end and a second end with a first longitudinal edge profile and a second longitudinal edge profile spaced from each other and extending between the first end and the second end;
- a plurality of void spaces formed within the pultruded panel;
- each void space filled with an insulating foam;
- the first longitudinal edge profile defined in part by a first lip extending laterally therefrom and a first recess formed in the pultruded panel;
- the second longitudinal edge profile defined in part by a second lip extending laterally therefrom and a second recess formed in the pultruded panel;
- at least one projection formed on one of the longitudinal edge profiles to create a gap when a longitudinal edge profile of another pultruded panel is disposed adjacent thereto; and
- the projection sized to allow the gap to receive an adhesive to bond the pultruded panel with an adjacent pultruded panel.
- 16.** The pultruded panel of claim 15 further comprising:
- the void spaces extending from respective openings in the first end to respective openings in the second end of the pultruded panel; and
- a respective covering placed over the openings at each end of the pultruded panel to block access to the void spaces.
- 17.** The pultruded panel of claim 15 wherein the projection further comprises a bead extending along at least a portion of one of the longitudinal edge profiles.
- 18.** The pultruded panel of claim 15 further comprising the projection selected from the group consisting of a bead, a button, serration or a rib.
- 19.** The pultruded panel of claim 15 further comprising more than two projections formed on the one longitudinal edge profile.
- 20.** A pultruded panel comprising:
- a generally rectangular configuration defined in part by a first end and a second end with a first longitudinal edge profile and a second longitudinal edge profile spaced from each other and extending between the first end and the second end;
- a plurality of void spaces formed within the pultruded panel;
- each void space filled with an insulating foam;
- the first longitudinal edge profile defined in part by a flange extending laterally therefrom;
- the second longitudinal edge profile defined in part by a recess size to receive a flange of another pultruded panel;
- the void spaces extending from respective openings in the first end to respective openings in the second end of the pultruded panel; and
- a respective covering placed over the openings at each end of the pultruded panel to block access to the void spaces.
- 21.** The panel of claim 20 further comprising:
- at least one projection formed on one of the longitudinal edge profiles to create a gap when a longitudinal edge profile of another pultruded panel is disposed adjacent thereto; and
- the projection sized to allow the gap to receive an adhesive to bond the pultruded panel with an adjacent pultruded panel.
- 22.** A railway car comprising:
- a railway car underframe having a generally rectangular configuration defined in part by a first end and a second

end with a first side and a second side spaced from each other and extending from the first end to the second end;

a floor assembly attached to the railway car underframe;

a pair of side wall assemblies mounted on respective sides of the railway car underframe;

a pair of end wall assemblies mounted on respective ends of the railway car underframe;

the side wall assemblies, end wall assemblies and floor assembly respectively coupled with each other;

a roof assembly attached to the end wall assemblies and the side wall assemblies opposite from the floor assembly;

an interior bulkhead attached to and spaced from an interior surface of one of the end wall assemblies;

a supporting structure disposed between the interior surface of the one end wall assembly and the interior bulkhead;

the interior bulkhead formed from a plurality of pultruded panels with each panel having at least two slots formed in at least one surface thereof; and

a plurality of attaching inserts respectively disposed within the slots for use in mechanically attaching the associated pultruded panel with the supporting structure.

23. The railway car of claim 22 wherein each insert further comprises:

an insert body having a pair of opposite exterior surfaces sized to be received within one of the slots of the associated pultruded panel;

a first opening formed in and extending through the insert body;

a second opening formed in an adjacent portion of the associated pultruded panel;

a third opening formed in the supporting structure;

a bolt extending through the first opening in the insert body;

a first end of the bolt attached to a first mechanical stop disposed within the second opening to engage the insert body with the pultruded panel;

a second end of the bolt extending through the third opening in the supporting structure; and

a second mechanical stop attached to the second end of the bolt to securely engage the associated pultruded panel with the supporting structure.

24. The railway car of claim 22 further comprising:

an open formed in the interior bulkhead to provide access to portions of an associated temperature control system;

a door attached to the opening;

the door having a first position blocking access through the open and a second position allowing access through the opening; and

the door resting against adjacent portions of the interior bulkhead when the door is in its second position.

25. The railway car of claim 22 wherein the supporting structure further comprises:

a plurality of support beams with each support beam having a generally I shaped cross section defined in part by a respective web attached to and extending between a first flange and a second flange;

the first flange securely attached with adjacent portions of the associated end wall assembly;

a plurality of openings formed in each of the webs to allow circulation of airflow therethrough; and

a plurality of openings formed in the second flange of selected support beams for mechanical engagement with one of the inserts.

26. The railway car of claim 25 wherein the openings formed in the web further comprise a generally football shaped configuration.

27. The railway car of claim 22 wherein at least one insert further comprises an insert body formed from an aluminum alloy.

28. The railway car of claim 22 wherein at least one insert further comprises an insert body formed from an aluminum extrusion.

29. A railway car comprising:

a railway car underframe having a generally rectangular configuration defined in part by a first end and a second end with a first side and a second side spaced from each other and extending from the first end to the second end;

a floor assembly disposed on and attached to the railway car underframe;

a first end of the floor assembly located proximate the first end of the railway car underframe;

a second end of the floor assembly located proximate the second end of the railway car underframe;

a central portion of the floor assembly disposed between the first end and the second end of the railway car underframe;

the central portion of the floor assembly securely bonded with adjacent portions of the railway car underframe;

at least one restraining anchor coupled with the floor assembly and the railway car underframe proximate the first end thereof;

at least a second restraining anchor coupled the floor assembly and the railway car underframe proximate the second end thereof; and

the restraining anchors cooperating with each other to allow only limited movement of the floor assembly relative to the railway car underframe during thermal expansion and contraction of the floor assembly.

30. The railway car of claim 29 wherein each restraining anchor further comprises:

a first member securely coupled with a portion of the floor assembly;

a second member securely coupled with adjacent portions of the railway car underframe;
at least one of the first and second members having a slot formed therein; and
a bolt extending through the first member, the slot and the second member to allow limited movement of the first

member relative to the second member during thermal expansion and contraction of the floor assembly relative to the railway car underframe.

* * * * *