

(19) World Intellectual Property Organization  
International Bureau



(43) International Publication Date  
19 April 2001 (19.04.2001)

PCT

(10) International Publication Number  
**WO 01/28220 A1**

(51) International Patent Classification<sup>7</sup>: H04M 15/00

(21) International Application Number: PCT/US00/27977

(22) International Filing Date: 10 October 2000 (10.10.2000)

(25) Filing Language: English

(26) Publication Language: English

(30) Priority Data:  
09/417,266 12 October 1999 (12.10.1999) US

(63) Related by continuation (CON) or continuation-in-part (CIP) to earlier application:  
US 09/417,266 (CON)  
Filed on 12 October 1999 (12.10.1999)

(71) Applicant (for all designated States except US):  
**AMERITECH CORPORATION** [US/US]; 2000 W.  
Ameritech Center Drive, Hoffman Estates, IL 60196-1025  
(US).

(72) Inventors; and

(75) Inventors/Applicants (for US only): **MAROPIS, Samuel, George** [US/US]; 444 Rockland Road, Crystal Lake, IL 60014 (US). **MOSS, John, Wesley** [US/US]; 505 Red Bridge Road, Lake Zurich, IL 60047 (US). **BREZINSKI, David, D.** [US/US]; 701 Wildwood Lane, Streamwood, IL 60107 (US). **THABIT, Mark, Joseph** [US/US]; 1244 West Wellington, Chicago, IL 60657 (US).

(74) Agent: **GENIN, Kent, E.**; Brinks Hofer Gilson & Lione, P.O. Box 10087, Chicago, IL 60610 (US).

(81) Designated States (national): AE, AG, AL, AM, AT, AU, AZ, BA, BB, BG, BR, BY, BZ, CA, CH, CN, CR, CU, CZ, DE, DK, DM, DZ, EE, ES, FI, GB, GD, GE, GH, GM, HR, HU, ID, IL, IN, IS, JP, KE, KG, KP, KR, KZ, LC, LK, LR, LS, LT, LU, LV, MA, MD, MG, MK, MN, MW, MX, MZ, NO, NZ, PL, PT, RO, RU, SD, SE, SG, SI, SK, SL, TJ, TM, TR, TT, TZ, UA, UG, US, UZ, VN, YU, ZA, ZW.

(84) Designated States (regional): ARIPO patent (GH, GM, KE, LS, MW, MZ, SD, SL, SZ, TZ, UG, ZW), Eurasian patent (AM, AZ, BY, KG, KZ, MD, RU, TJ, TM), European

[Continued on next page]

(54) Title: METHOD AND APPARATUS FOR PROVIDING PREPAID LOCAL TELEPHONE SERVICES

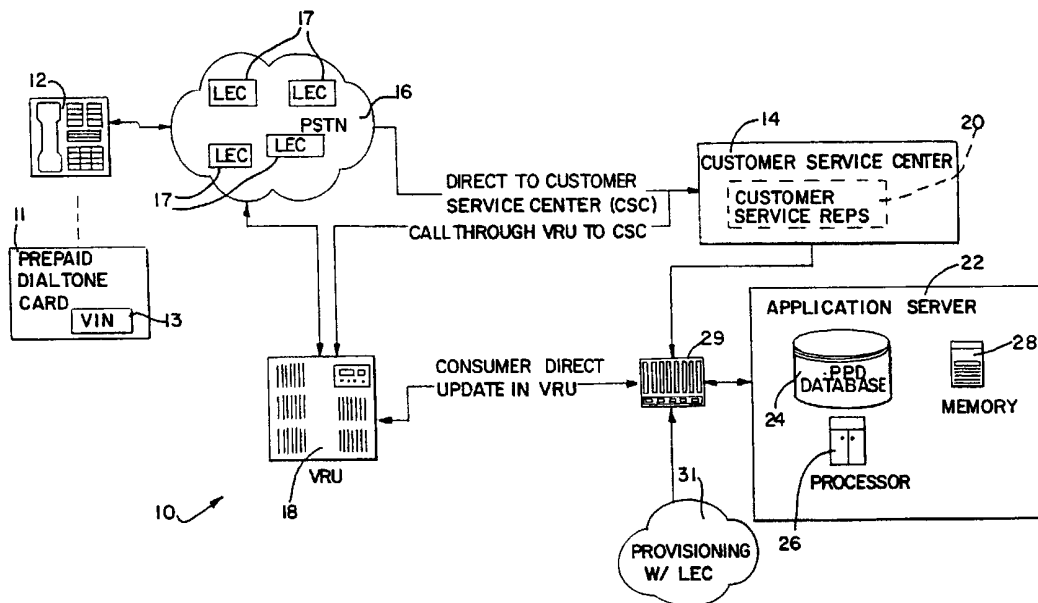

(57) Abstract: A system and method for providing prepaid dialtone services. The system includes a prepaid dialtone service center (14) that maintains a prepaid dialtone subscriber database including subscriber identification and service period information. The applications server (22) is configured to automatically remind subscribers to renew their prepaid dialtone account and communicates with a local exchange carrier (17) to place a hold on, or cancel, an expired subscriber account. The method includes the features of determining and monitoring a service period for a prepaid dialtone subscriber, communicating a reminder to the subscriber prior to expiration of the service period, and communicating with a local exchange carrier servicing the subscriber upon expiration of the service period.

WO 01/28220 A1



patent (AT, BE, CH, CY, DE, DK, ES, FI, FR, GB, GR, IE, IT, LU, MC, NL, PT, SE), OAPI patent (BF, BJ, CF, CG, CI, CM, GA, GN, GW, ML, MR, NE, SN, TD, TG).

*For two-letter codes and other abbreviations, refer to the "Guidance Notes on Codes and Abbreviations" appearing at the beginning of each regular issue of the PCT Gazette.*

**Published:**

— *With international search report.*

## METHOD AND APPARATUS FOR PROVIDING PREPAID LOCAL TELEPHONE SERVICES

### BACKGROUND OF THE INVENTION

5           Subscribers of local telephone services often sign up for telephone services that are billed out on a monthly basis. Occasionally, some subscribers who are financially capable of paying their bills have difficulty making timely payments for their local telephone services. These late payments result in late payment penalties for the subscriber and added costs  
10 to the telephone service provider. In extreme cases the subscriber's delinquency can adversely affect her credit rating. In an attempt to solve this problem, several types of prepaid telephone services are available that allow for a subscriber to prepay for services.

          One existing type of system treats prepaid local telephone services  
15 (hereinafter "prepaid dialtone") in the same manner as a conventional long distance prepaid card service. The local exchange carrier (LEC) and/or interexchange carrier (IXC) for a particular subscriber will forward all calls to a dedicated prepaid dialtone switch that will determine if the caller has a credit balance in her account. If the prepaid dialtone switch determines that the call  
20 can go through, it then routes the call to the local end office and maintains an active connection to the call so that the prepaid dialtone switch may monitor the call and update its database after the call. A disadvantage of this form of prepaid dialtone is that the telephone network needs to maintain a continuous connection to the database monitoring the prepaid subscriber so that the time  
25 of the call is monitored and the charges will be debited on, for instance, a per second basis.

          Another version of a prepaid dialtone system utilizes a separate billing service that generates monthly statements and posts deposits received. This system acts to accept prepayment of services but does not adequately  
30 address the problem of late payments because there is no mechanism for

automatically limiting a subscriber's usage or automatically shutting off the subscriber's service at the end of the prepaid service period.

Accordingly, there is a need for an improved system and method of implementing prepaid dialtone services.

## 5 BRIEF DESCRIPTION OF THE DRAWINGS

FIG. 1 illustrates a prepaid local telephone service applications system according to a preferred embodiment;

FIG. 2 illustrates a prepaid dialtone database for use in the system of FIG. 1;

10 FIG. 3 illustrates an advanced intelligent network structure in a local exchange carrier configured to cooperate with the system of FIG. 1;

FIG. 4 is a flow diagram of a method of implementing prepaid dialtone services with the system of FIG. 1;

15 FIG. 5. is a flow diagram of a method of renewing a prepaid dialtone account according to a preferred embodiment.

## DETAILED DESCRIPTION OF THE PRESENTLY PREFERRED EMBODIMENTS

The present invention provides for an efficient and configurable system and method for implementing and monitoring prepaid dialtone services that  
20 avoids the billing difficulties and telephone network resource usage of existing versions of prepaid dialtone services. FIG. 1 illustrates a telecommunications system 10 according to a preferred embodiment. The system preferably includes at least one subscriber at a subscriber telephone 12 in  
communication with a prepaid local telephone service center 14 via a service provider network, often referred to as a local exchange carrier (LEC) 17, that  
25 is part of the public switched telephone network (PSTN) 16. The subscriber telephone 12 may communicate directly with the prepaid local telephone service customer service center 14 directly or via a voice recognition unit (VRU) 18. The subscriber telephone may be a plain old telephone system  
30 (POTS) telephone in communication with a standard subscriber line that provides telephone service to the subscriber's fixed address. As set forth in

more detail below, each LEC 17 preferably has advanced intelligent network (AIN) capabilities. The VRU 18 may be any of a number of commonly available VRU's, such as those available from Dialogic Communications Corporation of Franklin, Tennessee, that offer voice and touch tone  
5 recognition and response abilities. Preferably, the VRU will be configured to query callers of the service center 14 for information and provide automated account information.

The service center 14 includes at least one customer service agent 20 for receiving initial prepaid dialtone service requests and general customer  
10 service questions. Each customer service agent 20 receives a call from a subscriber after the subscriber has been screened by the VRU 18 to determine the subscriber's needs. Alternatively, the subscriber may access the customer service center without going through the VRU. The service center is in communication with an application server 22, such as those  
15 commonly available from IBM Corporation, containing a prepaid dialtone database 24, a processor 26 and a memory 28. Preferably the processor 26 of the applications server 22 monitors the status of the various subscriber records and manages communications with the telephone network 16 and other resources. In one embodiment, the customer service center 14, VRU  
20 18 and application server 22 may communicate through a hub 29. A provisioning network 31 receives account activation and subsequent account status information generated by the customer service center 14 or applications server 22, via hub 19, when a prepaid dialtone subscriber establishes an account or when the account status changes. The  
25 provisioning information generated by the customer service center 14 or application server 22 may reach the LEC 17 for the subscriber through any of a number of provisioning channels that the particular LEC already uses when provisioning services.

As shown in FIG. 2, the prepaid dialtone database 24 includes a record  
30 30 for each subscriber to the prepaid dialtone service. Each record 30 preferably contains fields for subscriber identification 32 and history 34, the applicable service plan 36, the rate plan 38 (e.g., the cost for the service

period associated with the service plan), the service dates 40, and account status 42. The subscriber identification field 32 may include information such as subscriber name, telephone number, address and a unique subscriber ID. The subscriber history field 34 may include two types of information: customer service notes and transaction records. The customer service notes may contain information entered by customer service agents 20 who have previously spoken with the subscriber. The transaction records are a log of service activations and renewals that are automatically generated when a subscriber initiates or renews the prepaid dialtone service. Transaction records may include previous activation dates, times and dollar amounts, as well as the value identification number (VIN) 13 of the prepaid dialtone service card 11 (see FIG. 1) used and the telephone number from which the activation/renewal call was made.

The account status field 42 reflects whether a prepaid dialtone subscriber account is active or on hold. The service plan field 36 of the subscriber record 30 contains a product code representative of the specific version of prepaid dialtone service applicable to the subscriber. The service dates field 40 stores the start and end dates of the present period for which the prepaid dialtone service is active.

As shown in FIG. 3, a suitable LEC 17 may be an advanced intelligent network (AIN) capable network. The network may include one or more service switching points (SSP) 44 in communication with one or more service control points (SCP) 46 via one or more service transfer points (STP) 48. A subscriber telephone 12 preferably is in communication with an SSP 44 over a voice channel.

The SSP 44 is a programmable switch having the ability to recognize AIN triggers for calls requiring special services. The SSP 44 may be an end office or tandem switch and communicates with a SCP 46. The subscriber telephone 12 communicates with the SSP 44 over a voice/information channel such as an ordinary telephone line. Multiple connections and combinations of network elements are usable with the present invention. For example, a subscriber on a subscriber telephone 12 may also communicate with a SSP

44 through one or more ordinary switches. In one preferred embodiment, the SSP is configured to receive and store line class codes from the LEC provisioning system 31 (FIG. 1) representative of the version of prepaid dialtone service offered by the particular LEC. The line class code is associated with a particular subscribers telephone number and instructs the SSP to, for example, verify that calls from the subscriber are of the type permitted under the subscribed prepaid dialtone services.

The service control point (SCP) 46 is a network element containing logic and data necessary to provide functionality required for the execution of a desired communication service. A SCP 46 generally permits separation of service logic from switching functionality such that additional services may be developed without the need to provision significant software in each individual SSP. A suitable SCP 46 is the Advantage SCP manufactured by Lucent Technologies. In a preferred embodiment, the SCP 46 contains service logic for prepaid dialtone services and is also configured to receive a set of records of subscriber names, their telephone numbers and the service time limit at provisioning. This subscriber information originates in the service center 14 and the records are stored in the application server 22 and the memory 50 in the SCP 46. The memory 50 may be integral with the SCP or may be a separate memory device accessible by the SCP 46.

The SCP 46 communicates with SSPs 44 over a data channel via at least one service transfer point (STP) 48. A suitable data signal intended for use with the STPs is the American National Standards Institute (ANSI) signalling system No. 7 (SS7). A suitable SCP/SSP communication protocol is the AIN 0.1 SCP/SSP protocol set forth in Bellcore Technical Reference TR-NWT-001285, entitled AIN Switch-Service Control Point Application Protocol Interface Generic Requirements, Issue 1, August 1992. Other configurations of AIN capable networks may be used to implement a preferred method and system for providing prepaid dialtone services. Additionally, multiple service provider networks, also referred to herein as local exchange carriers (LECs) 17, may access the services of the prepaid dialtone

provisioning system 10 so that the prepaid dialtone provisioning system will monitor and maintain all subscriber account records for each of the LECs 17.

In one embodiment, the SSP 44 may be configured to recognize an off-hook delay trigger from a subscriber line when a subscriber picks up the telephone and dials a number. If the subscriber is a prepaid dialtone subscriber, the SSP preferably contains a line class code associated with the subscriber's telephone number. The line class code for prepaid dialtone subscribers contains instructions for the SSP to verify that the telephone number dialed by the subscriber is a non-toll intra-LATA (Local Access and Transport Area), toll-free, or 911 call. If the SSP determines that the number does not fall within the allowable category of calls, the call is not connected. Instead, the off-hook delay trigger is escaped and the call is terminated to treatment in the SSP. If the call made by the prepaid dialtone subscriber is an allowable call, the SSP communicates with the SCP and the SCP verifies that the prepaid dialtone account for the subscriber is valid. If the account is still valid, the SCP instructs the SSP to connect the call.

Referring now to FIG. 4, a method of implementing prepaid dialtone service is described below with relation to the system shown in FIGS. 1-3. When a subscriber 12 desires to participate in the prepaid dialtone service, the subscriber must first purchase a prepaid dialtone card 11. The cards may be purchased from designated retail establishments. The cards will each have a unique value identification number (VIN) that associates a fixed value to a particular card in a prepaid telephone card database. Once a card 11 has been purchased, the customer service center 14 and the VRU 18 will serve as the primary interface for providing the service to the subscriber 12. Although a card having a unique VIN is described herein, a card is not necessary. The VIN may be printed on other items, or may be verbally provided to a subscriber upon purchase, in other embodiments.

To initiate service after purchasing a card 11, the subscriber 12 will call into the service center 14 to initiate service. In one embodiment, all calls to the service center first arrive at a VRU that screens the call and offers a menu of touchtone response options to direct the call to an appropriate location. In



other embodiments, calls to the service center may arrive directly at the service center 14. The service center 14 may be a live operator who, in real time, assists the caller. In another embodiment, the service center may be an Internet-based service center capable of accepting and processing service requests. The subscriber 12 will provide the customer service agent 20 with information such as the address for the service and the VIN number 13 of the card 11. After verifying the address information and verifying that the VIN number 13 is valid, the customer service agent 20 will provide the subscriber with a telephone number and installation date for the service.

The customer service agent will communicate with the applications server 22 to initiate a service order that may be processed through a standard automated provisioning system in communication with the LEC 17 for the subscriber 12. Preferably the interface used for provisioning the prepaid dialtone service is an interface such as a standard electronic data interface (EDI) or other type of interface which is capable of connecting to customized interfaces used by the specific LECs of the subscribers to the prepaid dialtone service. After receiving a new prepaid dialtone service request, the service order is entered on the prepaid dialtone database and a provisioning request will be sent to provisioning system 31 and, in a preferred embodiment, results in all the necessary Universal Service Order Codes (USOCs), line class code orders, and field identifiers (FIDs) for the requested version of prepaid dialtone being delivered to the LEC. The USOC is preferably a package USOC that defines a set of individual feature USOCs (e.g., call waiting, voicemail, etc.). Thus, the package USOC represents to the LEC the general type of service order and all the individual features packaged into the service order. In another embodiment, individual feature USOCs may be used in an unbundled form to provide the service order. Line class codes refer to a switch based translator for a particular service that decides which call features are allowed and FIDs refer to codes in a service order that are related to particular services or features.

In a preferred embodiment, the LEC 17 may implement the prepaid dialtone service in one of two ways depending on the state rules for handling

local telephone calls. In states such as Ohio and Indiana where there is no metered service for local calls, the LEC may implement the prepaid dialtone service for a particular subscriber by storing a line class code associated with the subscriber and the prepaid dialtone service in the SSP. In a preferred embodiment, the SCP does not interact with the SSP and the SSP handles all prepaid dialtone calls. In another embodiment, the LEC of states with no metered service for local calls may provide the appropriate SCP with the subscriber's telephone number and an account status indicator (e.g., a variable indicating whether the subscriber account is current or expired) to a memory 50 (see FIG. 3) associated with, or in communication with, an SCP 46 so that the SCP may control whether the SSP may continue connecting local telephone calls for the subscriber. With this network implementation of the prepaid dialtone service, the SSP 44 and SCP 46 cooperate to make sure the subscriber's prepaid dialtone account is current and that the call made by the subscriber is a local call. In either embodiment, the LEC does not continuously meter the call, debit a monetary amount associated with a call, or put a limit on the time of any local calls. Other network implementations, such as an AIN network where the SCP performs both the tasks of identifying local calls and account status, are also contemplated.

In states where the local telephone services are metered, for example in Illinois, Wisconsin or Michigan, the LEC 17 will again preferably provide the SSP with a line class code associated with the subscriber's telephone number that will cause the SSP to permit local calls. In metered states, however, the prepaid telephone services are implemented in the SCP by providing the SCP 46 with the subscriber's telephone number, a day counter and a call counter to provide a fixed number of local telephone calls to a subscriber for a given service period. The number of calls allowed may be set at a number greater than the average number of calls subscribers make in a given time period to allow for normal calling habits. For example, assuming that 270 calls per month is the average number of calls, the SCP may be programmed to allow 400 calls in a thirty day period for prepaid dialtone subscribers. As with LECs in the non-metered states, the SCP and SSP do not continuously monitor

prepaid telephone calls, do not associate a value/rate with a call or debit a value from an account, and do not limit the length of local telephone calls. In the metered call states, however, the SCP will keep track of a set service period, decrement a call counter every time a local call is completed, and prohibit all calls after a predetermined number of calls have been completed in the service period.

In either situation, metered state or non-metered state, the SCP preferably does not communicate with the prepaid database. As shown in FIG. 4, the prepaid database 24 keeps track of the service period for each subscriber 12 and operates to automatically remind subscribers of service expiration due dates and automatically communicate service order changes to the LEC if a prepaid dialtone subscriber's account status has changed. As soon as an account is established (at 70), the prepaid subscriber database determines the service period end date for the subscriber (at 72). In one embodiment, a subscriber may renew for a fixed 30 day period. For new subscribers, the application server 22 will determine the date corresponding to 30 days from the service installation date and store that information in the service dates field 40 of the subscriber record 30 in the prepaid dialtone database 24. For renewing subscribers, the applications server will determine the date corresponding to thirty days from the end of the subscriber's current service period. For renewing subscribers who are renewing after the expiration of their previous service period, but before the expiration of the grace period (see below), the service period end date is calculated as 30 days from the date the subscriber's service becomes active. As with new subscribers, the service period dates are stored in the service dates field 40 of the subscriber record 30. Although a service period of 30 days is specifically addressed here, any service period length may be implemented as desired.

After determining the service period, the applications server 22 monitors the subscriber service periods by scanning the prepaid dialtone database 24 on a daily basis (at 74). At a desired time before the expiration of a subscriber's service period, the applications server will send instructions to a notification service to automatically notify the subscriber that the service

period will expire in a certain number of days (at 76). In one embodiment, the automatic notification may be in the form of a voice mail that supplies termination date information and is automatically generated and delivered five days before the service period expires. In another embodiment, the notification service may be an automatic calling device that will telephone the subscriber and play a prerecorded reminder message. In other embodiments, an additional renewal reminder message may be provided, other reminder periods may be implemented or the subscriber may be given the option of selecting how far in advance she wishes to be reminded to renew and/or informed of a service termination date.

After notifying the subscriber, the applications server continues to keep track of subscriber account status and check on whether the subscriber has renewed (at 78). If the subscriber has renewed, the process begins again with the applications server calculating the new service period and so on. If the service period expires and the subscriber has not renewed in time, the applications server generates an instruction directed to the subscriber's LEC 17 to change the subscriber account status (at 80). In a preferred embodiment, the applications server allows the subscriber a grace period in which to renew her account by instructing the LEC to put the account on hold, such as a vacation-type hold or other suspend/hold-type account, for example where no dialtone service is provided but where the telephone line is still connected. In this manner, the prepaid dialtone subscriber is given a period of time to renew the account without the account being terminated and the subscriber having to pay a fee for reconnecting the telephone service and receiving a new telephone number in addition to renewing the prepaid dialtone service. In another embodiment, the prepaid dialtone service may allow for emergency calls, such as a 911 call, during the grace period while blocking all other call attempts.

The applications server will continue to monitor the subscriber's account on a daily basis during a predetermined grace period to see if a renewal has been received (at 82). The grace period may be any desired length of time and in a preferred embodiment is five days. At the end of the

5 grace period, the applications server will automatically send instructions to the LEC to terminate and disconnect the subscriber's telephone service (at 84). In other embodiments, the applications server may just automatically send a termination order to the LEC at the end of the subscriber's service period so that the prepaid telephone service and the telephone line are terminated immediately after the service period expiration date.

10 Referring now to FIG. 5, a process for renewing a prepaid dialtone service account is shown. While a subscriber's account is still active, or within a grace period after expiration of the prepaid dialtone service period, the subscriber may renew her account for another service period. The subscriber will again obtain a non-reusable prepaid dialtone card having a fixed monetary value from a retail location (at 86). The subscriber will dial a service center 14 telephone number and a VRU 18 will receive the telephone call (at 88, 90). The VRU 18 will prompt the subscriber to select from a menu of options and the subscriber will select the account renewal option (at 92, 94).

15 When the VRU receives the subscriber's menu selection, the VRU will then request information from the subscriber including the VIN number of the prepaid dialtone card that the subscriber purchased (at 96). In one embodiment, the VRU 18 will determine if the caller is calling from her home and match the automatic number identification (ANI) information of the home number to an established prepaid dialtone account. The VRU 18, via the applications server 14, will verify with the prepaid dialtone card database that the VIN is valid and that the monetary value represented by the card is sufficient for the services requested. The applications server will renew the subscriber's account for another service period once the VIN and amount are verified (at 98). The VRU may also inform the subscriber of the new end date of the prepaid dialtone service she has just purchased.

20 In another embodiment, subscribers may pay for prepaid telephone service using a credit card rather than a single use prepaid dialtone card purchased at a retailer. In this embodiment, the VRU would ask the subscriber to select between a prepaid card or a credit card as a method of

payment, and the applications server would interact with the appropriate credit agency to determine if the credit card transaction is valid.

An advantage of the presently preferred system and method is that use of LEC resources is minimized. The LEC is not required to constantly monitor prepaid telephone calls and does not keep track of monetary values associated with subscriber accounts. Communication with the service center 14 is minimal and does not tie up LEC resources. In one embodiment, the LEC will maintain a call counter and a service period clock for prepaid dialtone subscribers in metered states. In non-metered states, no call counter or service period clock is necessary. Preferably, the service center, via a provisioning network, only communicates with an LEC to initially establish prepaid dialtone services or to change the status of an account if a subscriber fails to renew or renews late.

Unless the service center communicates information to the contrary, the LECs will automatically maintain active status for currently active prepaid dialtone subscribers. In metered states, the LEC will automatically reset the service period and call counter stored in memory 50 in the SCP 46 at the end of a given subscriber's service period. In non-metered states, the LEC will maintain active status for the prepaid subscribers unless a special instruction (such as a hold or a disconnect instruction) is received. In this manner, LEC resources are not burdened by the bulk of the administrative overhead of managing the prepaid subscribers. Instead, the subscriber accounts and account maintenance are handles by the remotely located service center 14.

In a preferred embodiment, different types of prepaid dialtone services may offered using the disclosed system and method. For example, in embodiment subscribers may be able to select a basic or a premium service for prepaid dialtone. Both basic and premium services could be based on a 30-day service period. The basic service features may include basic dialtone, a state-specific local calling plan, a directory listing, toll call blocking, PIC none (designating a feature that blocks a subscriber from utilizing long distance services), directory assistance (DA) and directory assistance with call completion (DACC) blocking, operator call (0+/0-) blocking except in

areas without 911, listing services, and no customer billing. The state-specific local calling plans may be as follows based on state/regional call metering regulations: Indiana and Ohio - unlimited local calling; Illinois (bands A & B calling permitted, band C blocked), Michigan, and Wisconsin – a preset limit on the number of local telephone calls allowed per service period. The basic prepaid dialtone service preferably has its own USOC, line class codes and FIDs and these would be invoked by the service instructions sent out to the LEC by the applications server. The premium service may include all the features of the basic service and the following features: voice mail, caller ID with name, call waiting, and non-published listing. As with the basic service, the premium service preferably has its own packaged USOC defining all the aspects of the service to the LEC supporting the subscriber.

In addition to the basic sign-up and renewal functions described above, the service center, via the VRU may allow subscribers who have existing prepaid dialtone service to retrieve account information on an as-needed basis. Utilizing the same telephone number that allows for the subscriber to sign-up for and renew service, preferably a toll-free number, a subscriber may access information offered by menu driven commands at the VRU. Such information may include the type of prepaid service the subscriber has established, the date the prepaid service will expire, etc. The VRU preferably also allows subscribers to select an option to be connected to a customer service agent 20.

As has been described above, by using a remotely located prepaid dialtone service center and an automated application server that tracks service periods and provides electronic provisioning instructions, and by providing local calls limited by service period and not a per-call time charge, LEC resources are not burdened by the continuous monitoring and administrative tasks of previous systems. Additionally, the customer service center and application server provide prepaid dialtone plan flexibility and avoids the need to replicate efforts and specially program hardware at each and every LEC interested in offering the prepaid dialtone service described above. The preferred method can permit automated sign-up and renewal of

prepaid dialtone services. The prepaid dialtone services provide subscribers with the ability to manage their telephone costs and allow LECs to reduce the billing difficulties associated with subscribers.

5 It is intended that the foregoing detailed description be regarded as illustrative rather than limiting, and that it be understood that the following claims, including all equivalents, are intended to define the scope of this invention.



We Claim:

1. A method for providing prepaid local telephone services to a subscriber having a telecommunications device connected to a subscriber line and in communication with a telephone network via the subscriber line, the method comprising:

receiving a telephone call from the subscriber;

identifying a subscriber account in a prepaid local telephone call database for the subscriber based on the telephone number of the subscriber;

receiving a value identification code associated with a prepaid local telephone service program;

determining a period of service for the identified subscriber account;

monitoring the period of service at the prepaid local telephone call database; and

sending termination date information to the subscriber prior to an expiration of the period of service.

2. The method of claim 1, wherein the telephone call from the subscriber is received at a voice recognition unit (VRU) in communication with the prepaid local telephone call database.

3. The method of claim 1, further comprising sending a renewal reminder message to the subscriber prior to expiration of the period of service.

4. The method of claim 1, further comprising detecting the end of the period of service and sending a message to a local exchange carrier in the telephone network, the message comprising a hold order for suspending a subscriber's prepaid local telephone service.

5. The method of claim 1, further comprising detecting the end of the period of service and sending a disconnect message to a local exchange carrier in the telephone network, the disconnect message comprising a disconnect order for terminating a subscriber's prepaid local telephone service.

5

6. The method of claim 4, further comprising monitoring a grace period after sending the message to the local exchange carrier.

7. The method of claim 6, further comprising detecting an end of the grace period and sending a second message to the local exchange carrier in the telephone network, the second message comprising a cancel order for canceling the subscriber's prepaid local telephone service.

10

8. In communication with a telephone network having at least one local exchange carrier in communication with at least one subscriber, a system for providing prepaid local telephone services comprising:

15

a prepaid local telephone call service center in communication with the at least one local exchange carrier, the prepaid local telephone service call service center comprising:

an applications server having a processor and a subscriber database, the subscriber database comprising subscriber service period information and subscriber identification information, the applications server further comprising means for automatically communicating service termination date information to a subscriber prior to an expiration of a service period for the subscriber.

20

9. The system of claim 8, further comprising means for automatically communicating a message to the local exchange carrier from the applications server upon the expiration of the service period for the subscriber.

25

10. The system of claim 9, wherein the message comprises a hold order containing instructions to suspend a prepaid local telephone service account for the subscriber.

5 11. The system of claim 9, wherein the message comprises a disconnect order containing instructions to disconnect a prepaid local telephone service account for the subscriber.

12. The system of claim 8, further comprising a grace period timer configured to monitor a grace period, the grace period comprising a period of time after the expiration of the service period for the subscriber.

10 13. The system of claim 12, further comprising means for automatically communicating a message to the local exchange carrier upon an expiration of the grace period.

15 14. A method of providing prepaid local telephone services to a subscriber having a telecommunications device connected to a subscriber line and in communication with a telephone network via the subscriber line, the method comprising:

establishing a subscriber account on a prepaid local telephone service database, the subscriber account comprising subscriber identification information and a period of service;

20 monitoring the period of service for the subscriber account at the prepaid local telephone service database; and

sending service termination information to the subscriber prior to an expiration of the period of service.

25 15. The method of claim 14, wherein establishing a subscriber account on a prepaid local telephone service database comprises:

receiving a telephone call from the subscriber;

creating a subscriber account in the database for the subscriber identified by the subscriber's telephone number;

receiving a value identification code associated with a prepaid local telephone service program;

5 determining a period of service for the identified subscriber account; and

sending a service order to a local exchange carrier for the subscriber via the telephone network.

10 16. A method of providing prepaid local telephone services to a subscriber having a telecommunications device connected to a subscriber line and in communication with a telephone network via the subscriber line, the method comprising:

15 establishing a subscriber account on a prepaid local telephone service database, the subscriber account comprising subscriber identification information and a period of service;

monitoring the period of service for the subscriber account at the prepaid local telephone service database;

sending a reminder message to the subscriber prior to an expiration of the period of service; and

20 sending a suspend message to the telephone network, the suspend message comprising an instruction to suspend local telephone service for the subscriber and to place the subscriber account on hold, wherein the subscriber account is maintained in an inactive state.

25 17. The method of claim 16, further comprising monitoring a grace period at the prepaid local telephone service database, the grace period comprising a predetermined length of time measured from when the suspend message is sent, and sending a disconnect message to the local exchange

carrier via telephone network after an expiration of the grace period if the subscriber has not renewed the subscriber account for an additional period of service, the disconnect message comprising an instruction to disconnect the subscriber account.

5           18.    The method of claim 16, wherein the suspend message further comprises an instruction to permit telephone calls to an emergency telephone number, wherein the subscriber account is maintained in an inactive state and only permits the subscriber to make telephone calls to the emergency telephone number.

10           19.    The method of claim 18, further comprising monitoring a grace period at the prepaid local telephone service database, the grace period comprising a predetermined length of time measured from when the suspend message is sent, and sending a disconnect message to the telephone network after an expiration of the grace period if the subscriber has not  
15 renewed the subscriber account for an additional period of service, the disconnect message comprising an instruction to disconnect the subscriber account.

FIG. 1

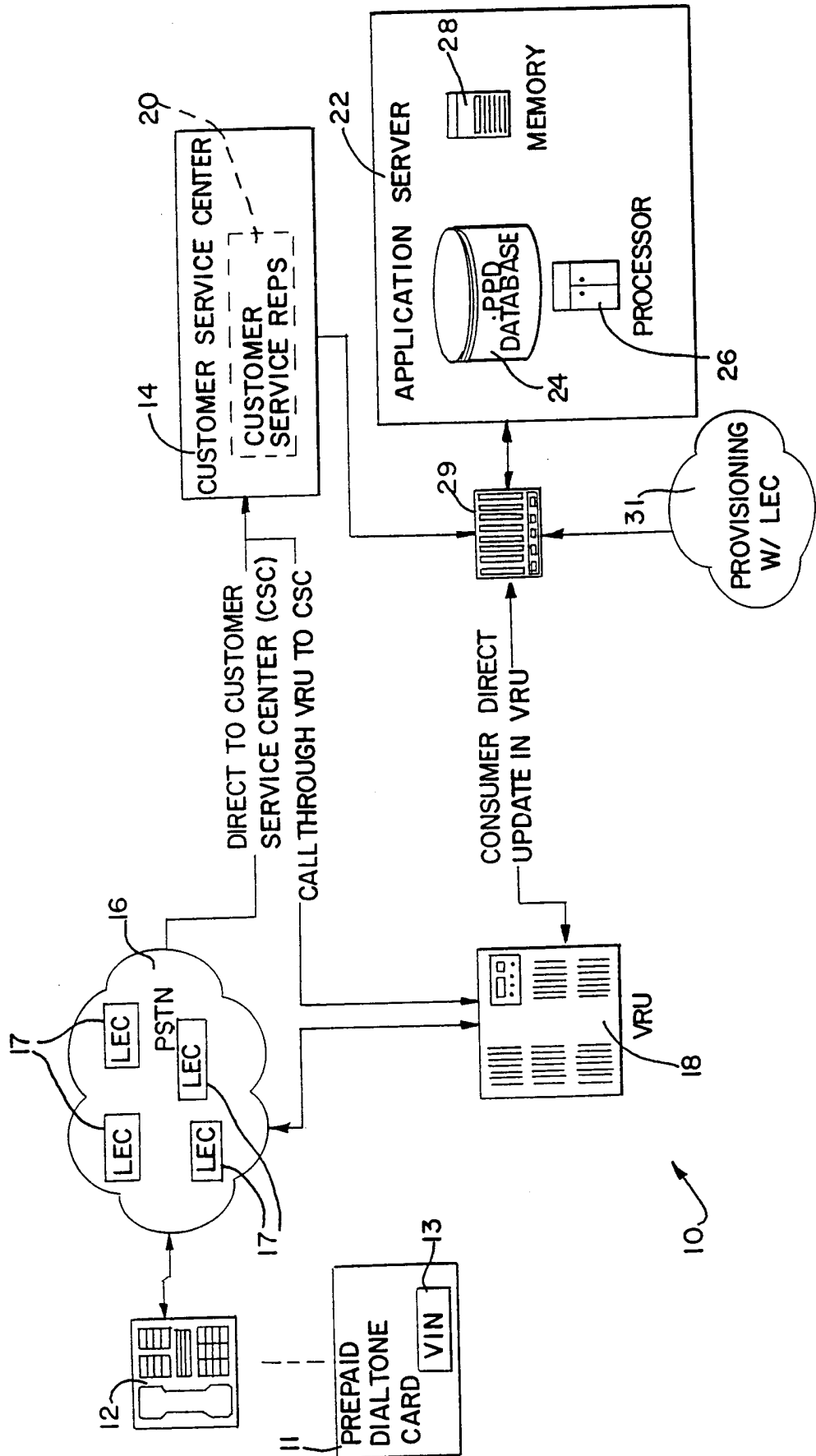

FIG. 2

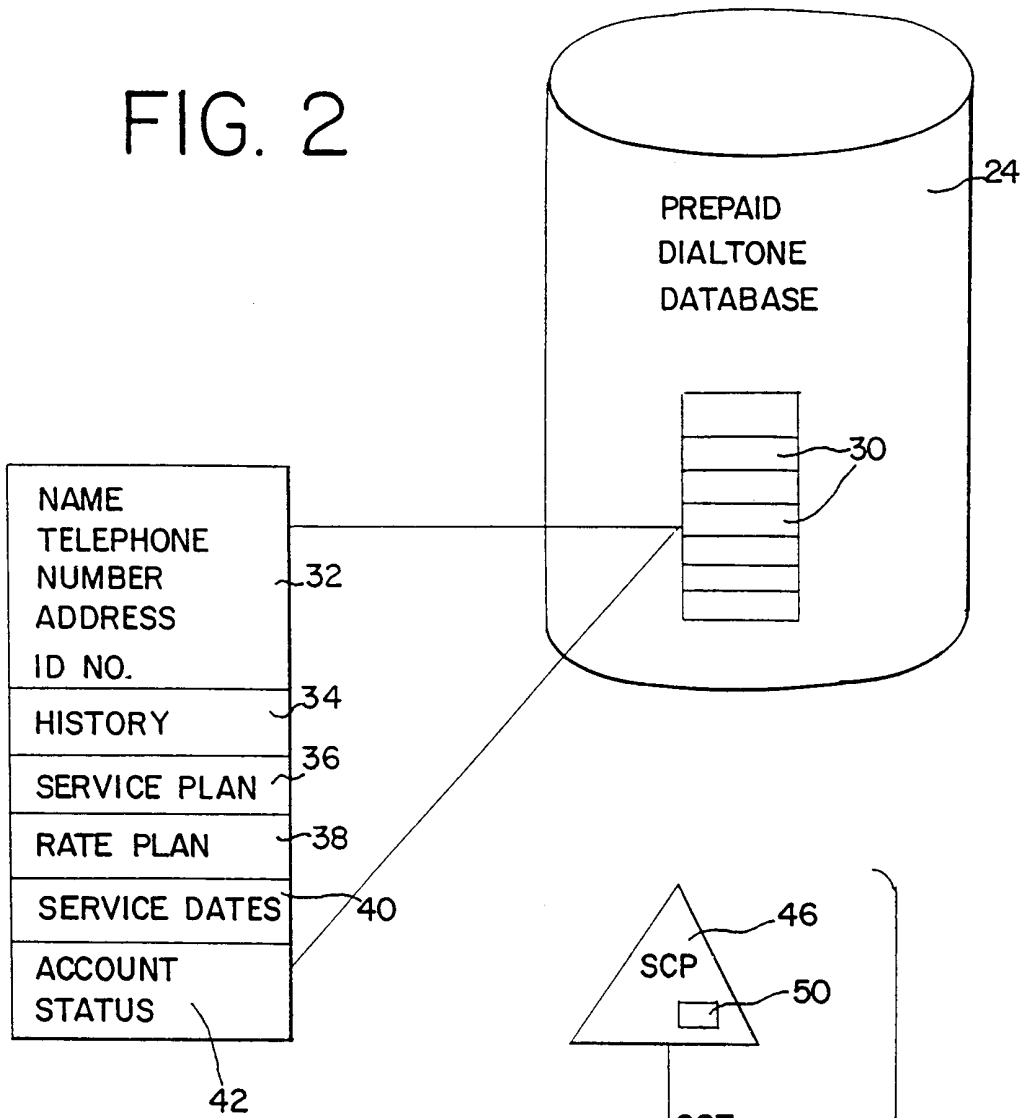

FIG. 3

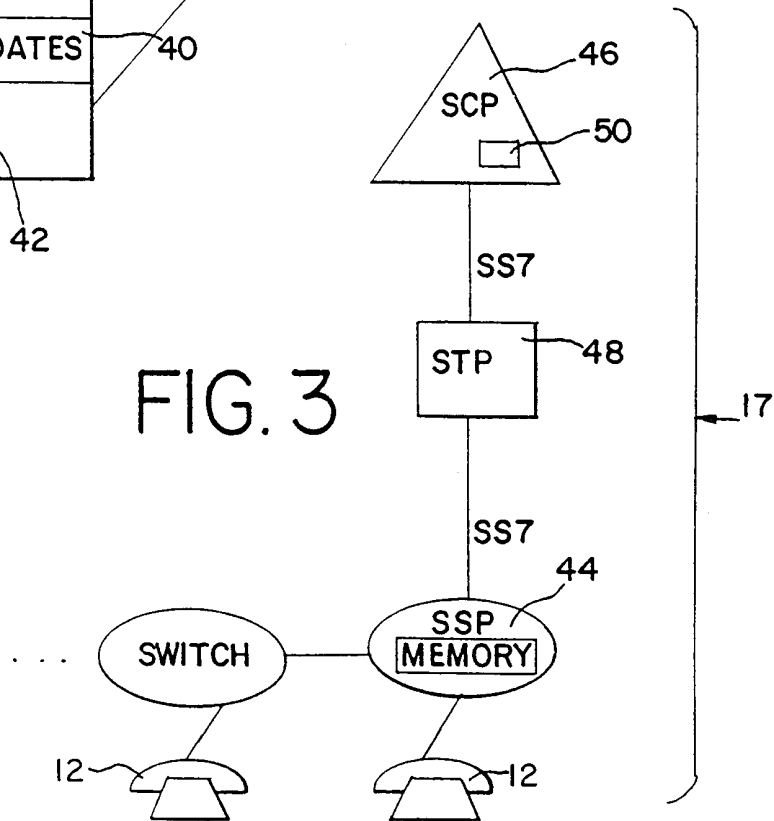

FIG. 4

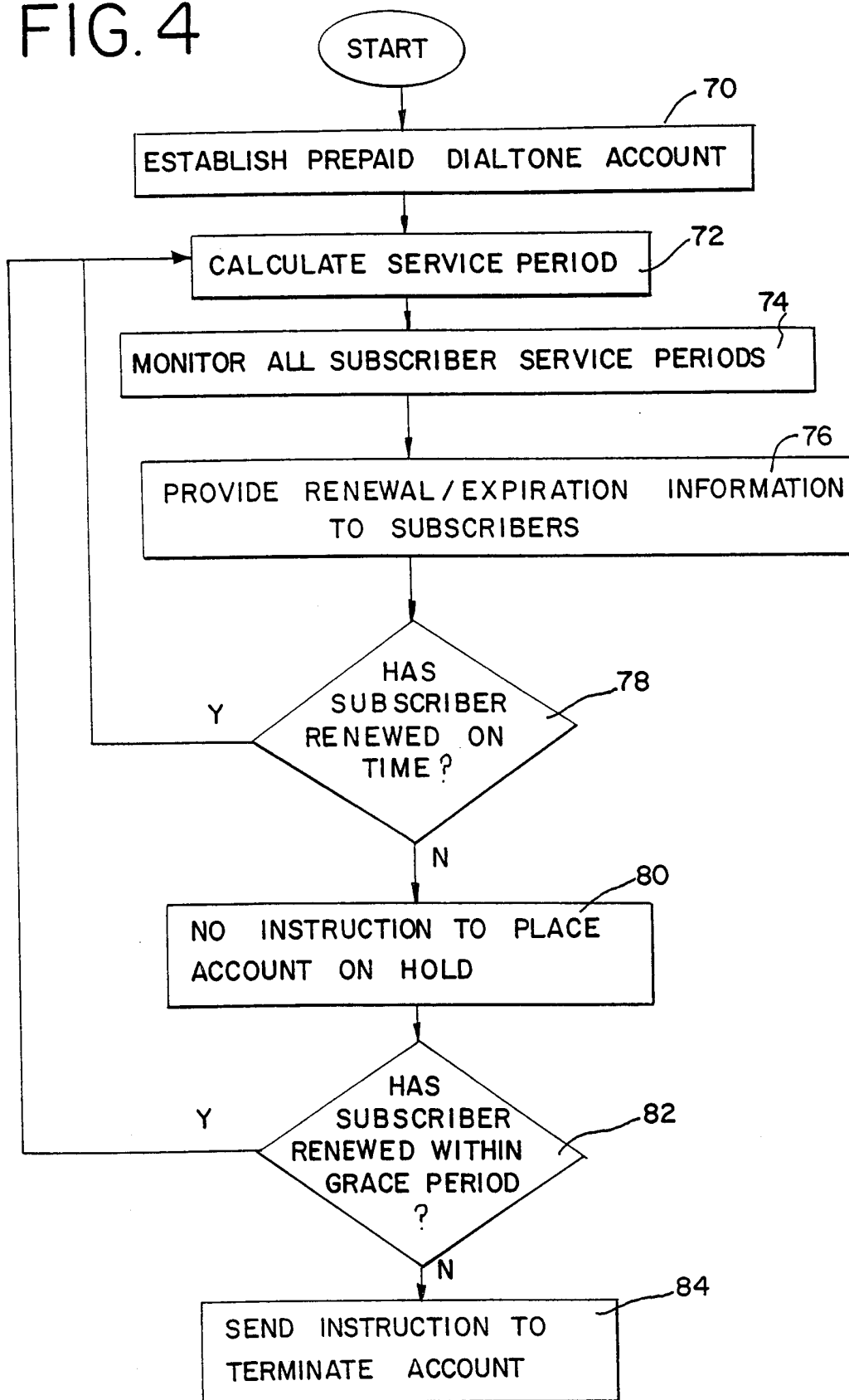
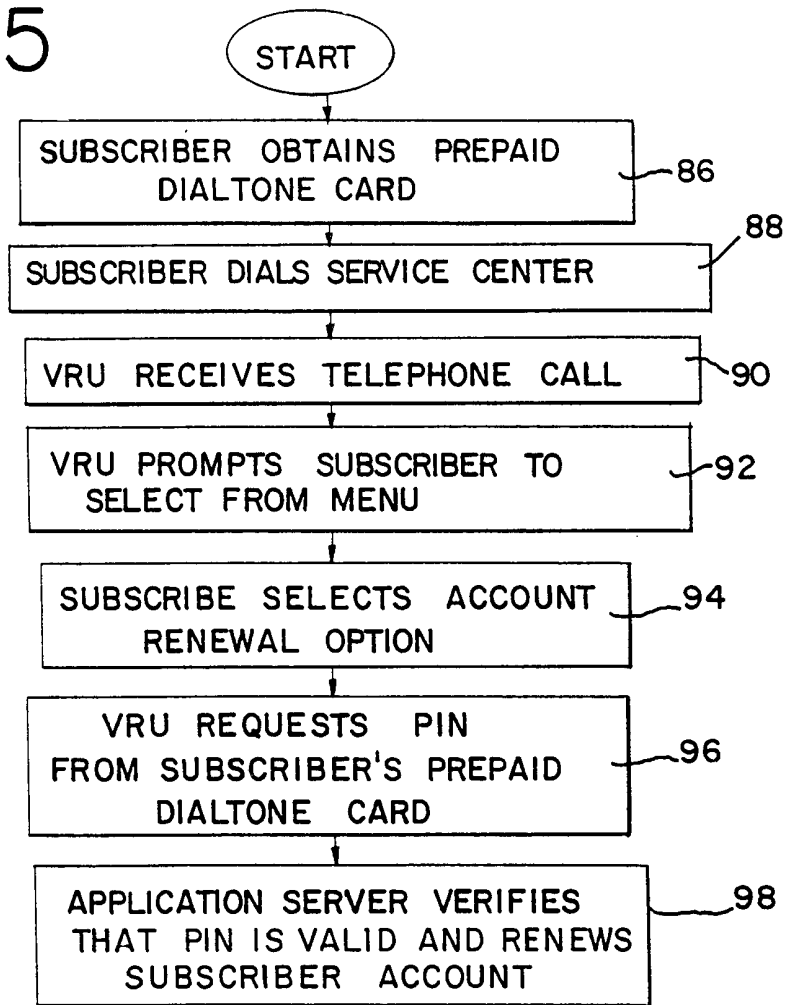



FIG. 5



# INTERNATIONAL SEARCH REPORT

International application No.

PCT/US00/27977

**A. CLASSIFICATION OF SUBJECT MATTER**  
 IPC(7) : H04M 15/00  
 US CL : 379/131  
 According to International Patent Classification (IPC) or to both national classification and IPC

**B. FIELDS SEARCHED**  
 Minimum documentation searched (classification system followed by classification symbols)  
 U.S. : 379/34, 88.01, 88.02, 88.12, 88.16, 88.17, 88.19, 88.2, 111, 114, 118, 130, 131, 201, 207

Documentation searched other than minimum documentation to the extent that such documents are included in the fields searched

Electronic data base consulted during the international search (name of data base and, where practicable, search terms used)

**C. DOCUMENTS CONSIDERED TO BE RELEVANT**

Category *	Citation of document, with indication, where appropriate, of the relevant passages	Relevant to claim No.
X --- Y	US 5,762,376 A (TASKETT) 09 June 1998 (19.06.1998), abstract, Fig. 4, Fig. 6, col. 1, lines 20-24, col. 3, lines 45-48, col. 7, lines 23-25, and col. 8, lines 3-40.	8-16 ----- 1-7
X --- Y	US 5,946,380 A (COHEN et al.) 31 August 1999 (31.08.1999), abstract, Fig. 1, Fig. 5, col. 3, lines 13-60, col. 4, lines 33-67, and col. 8, lines 35-40.	1 and 3-19 ----- 2
Y	US 5,844,972 A (JAGADISH et al.) 01 December 1998 (01.12.1998), abstract and col. 3, line 17 - col. 4, line 13.	1-7
A	US 5,448,633 A (JAMALEDDIN et al.) 05 September 1995 (05.09.1995).	1-19

Further documents are listed in the continuation of Box C.  See patent family annex.

* Special categories of cited documents:	"T"	later document published after the international filing date or priority date and not in conflict with the application but cited to understand the principle or theory underlying the invention
"A" document defining the general state of the art which is not considered to be of particular relevance	"X"	document of particular relevance; the claimed invention cannot be considered novel or cannot be considered to involve an inventive step when the document is taken alone
"E" earlier application or patent published on or after the international filing date	"Y"	document of particular relevance; the claimed invention cannot be considered to involve an inventive step when the document is combined with one or more other such documents, such combination being obvious to a person skilled in the art
"L" document which may throw doubts on priority claim(s) or which is cited to establish the publication date of another citation or other special reason (as specified)	"&"	document member of the same patent family
"O" document referring to an oral disclosure, use, exhibition or other means		
"P" document published prior to the international filing date but later than the priority date claimed		

Date of the actual completion of the international search: 02 January 2001 (02.01.2001)  
 Date of mailing of the international search report: 23 JAN 2001

Name and mailing address of the ISA/US: Commissioner of Patents and Trademarks, Box PCT, Washington, D.C. 20231, Facsimile No. (703)305-3230  
 Authorized officer: Fan S Tsang, Telephone No. (703) 305-4805  
*Kuzgenia Zogor*