

(19) **DANMARK**

(10) **DK/EP 2861110 T3**



(12)

Oversættelse af
europæisk patentskrift

Patent- og
Varemærkestyrelsen

-
- (51) Int.Cl.: **A 47 J 37/06 (2006.01)**
- (45) Oversættelsen bekendtgjort den: **2019-01-07**
- (80) Dato for Den Europæiske Patentmyndigheds bekendtgørelse om meddelelse af patentet: **2018-09-19**
- (86) Europæisk ansøgning nr.: **13731416.7**
- (86) Europæisk indleveringsdag: **2013-06-12**
- (87) Den europæiske ansøgnings publiceringsdag: **2015-04-22**
- (86) International ansøgning nr.: **FR2013051365**
- (87) Internationalt publikationsnr.: **WO2013186487**
- (30) Prioritet: **2012-06-15 FR 1255600**
- (84) Designerede stater: **AL AT BE BG CH CY CZ DE DK EE ES FI FR GB GR HR HU IE IS IT LI LT LU LV MC MK MT NL NO PL PT RO RS SE SI SK SM TR**
- (73) Patenthaver: **SEB S.A., 112 Chemin du Moulin Carron , Campus SEB, 69130 Ecully, Frankrig**
- (72) Opfinder: **Volatier, Sébastien, 17 rue des Molidors, 21000 Dijon, Frankrig**
LECERF, Joël, 18 rue de la Croix Picard, 50190 Periers, Frankrig
- (74) Fuldmægtig i Danmark: **Plougmann Vingtoft A/S, Strandvejen 70, 2900 Hellerup, Danmark**
- (54) Benævnelse: **TILBEREDNINGSAPPARAT OG FREMGANGSMÅDE TIL ANVENDELSE HERAF**
- (56) Fremdragne publikationer:
WO-A1-2007/140547
AU-A1- 2009 201 010
DE-A1- 4 302 190
US-A1- 2010 116 146

COOKING APPLIANCE AND A METHOD OF IMPLEMENTING THE SAME

The invention relates to a cooking appliance for cooking food, and to a method of implementing said cooking appliance.

5

1. Field of the invention

The present invention relates to the field of cooking appliances that include at least one heating plate for cooking food such as meat, fish, vegetables, or other foodstuffs. More precisely, the invention relates to a cooking appliance that makes it possible to determine the thickness of the food contained in said appliance.

10

2. Prior art

A food cooking appliance of this type is known from document DE 4 302 190. This document describes a cooking appliance that includes a first structure having a heating plate for cooking food, and a measurement device for measuring the thickness of the food in the appliance. The measurement device is equipped with two pivotally mounted rockers, each of which is connected via a first end to a pivoting shaft. The measurement device also includes measurement means for measuring the angle through which the rocker pivots so as to estimate the thickness of the food.

15

However, that appliance does not enable the thickness of the food to be estimated very reliably and it is not easy to use.

20

3. OBJECTS OF THE INVENTION

A particular object of the invention is to mitigate all or some of the drawbacks of the prior art.

25

More precisely, an object of the invention is to provide a cooking appliance that makes it possible to determine the thickness of the food in order to control and obtain automatic cooking of the food.

Another object of the invention is to guarantee the quality of the food, in particular its organoleptic quality, since the cooking time depends, among other factors, on thickness.

30

4. Summary of the invention

These objects are achieved by means of a cooking appliance as described by the subject matter of claim 1.

Thus, the moving second structure enables the appliance to be adaptable to the thickness of the food, and the distance then existing between the two structures enables the thickness of the food to be determined very reliably. Preferably, the first structure cooks the food against it.

5 According to an important characteristic, the second structure includes a heating plate adapted to cook said food against it by conduction while said food is disposed between the heating plates.

In this way, the food can be cooked uniformly and more quickly since both sides of the food are in contact with the heating plates.

10 In an embodiment, the rocker is rigidly connected to the pivoting shaft, or is mounted on the shaft with sufficient clearance to allow the rocker to pivot about the shaft. All of the possibilities for causing the rocker to pivot are considered, so that mounting is simple.

In an advantageous manner, the second structure is mounted on the shaft by means of lateral arms that are mounted to move relative to at least the first structure.

This arrangement facilitates mounting and saves time during manufacturing.

15 Preferably, each lateral arm comprises a first end connected to the shaft and a second portion connected to one side of the second structure, in the vicinity of the middle of said side.

The lateral arm as arranged in this manner makes it possible to take an average measurement of the food, and to manage a lack of parallelism between the two structures.

20 According to another important characteristic, the rocker has a first end engaged with a first end of one of the lateral arms where the lateral arm is connected to the shaft, this engagement being established until the lateral arm reaches a pivot angle beyond which said lateral arm disengages from the rocker, so that the lateral arms then continue to pivot without the rocker continuing to pivot.

25 This arrangement firstly makes it possible to increase the accuracy of the measurements over a range corresponding approximately to a thickness of food, and secondly makes it possible for the second structure to open without the measuring means being continuously under stress.

Advantageously, the predetermined pivot angle of the lateral arms corresponds to the predetermined pivot angle of the rocker that lies in the range from 10° to 30°.

30 According to yet another advantageous characteristic, the predetermined pivot angle of the rocker corresponds to the first and second structures being in an intermediate open state in which they are substantially parallel to each other.

According to an important characteristic, the rocker is connected, in the vicinity of its second end, to actuation means for actuating the measurement means. This arrangement enables the

rocker to actuate the measurement means easily, thereby giving an image of the angle through which the lateral arm has travelled and, as a result, giving accurate information about how far the structures are spaced apart, and therefore about the thickness of the food.

According to a preferred embodiment, the measurement means comprise a potentiometer.

5 The use of a potentiometer is a solution that is simple, very inexpensive, and easy to mount.

Advantageously, the rocker is provided with first and second fingers, the actuation means for actuating the measurement means form a lever driven by the second finger and biased by biasing means that keep the rocker and the lever in contact with each other during the separation movement of the second structure. The use of a lever enables the rocker to drive the measurement
10 means as soon as the second structure opens. In addition, the biasing means enable the construction clearances to be reduced.

According to another embodiment, the actuation means comprise a toothed wheel driven by a rack on the rocker, and biased by biasing means that keep the rocker and the toothed wheel in contact with each other during the separation movement of the second structure.

15 In another embodiment, the measurement means comprise a strain gauge. Using a strain gauge is a solution that is also simple and applicable to the appliance as mentioned above and does not require any modification thereof.

In yet another embodiment, and for reasons of simplicity, the measurement means comprise an optical detection system with a photodetector.

20 The invention also provides a method of implementing a food cooking appliance. This method includes a step of adjusting the appliance, prior to use, whereby the user selects a key or a combination of keys with which the appliance is provided.

Thus, all of the errors and uncertainties due to the repeated use and to the wear of the parts are compensated.

25

3. List of the figures

Other characteristics and advantages of the invention appear clearly from the following description that is given below by way of non-limiting indication, with reference to the accompanying drawings, in which:

- 30 -
- Figure 1 is a perspective view of the cooking appliance of the invention;
 - Figure 2 is an exploded view of the appliance of the invention;
 - Figure 3 is a side view of the appliance when open;

- Figure 4 is a detailed view of the measurement device as mounted on the appliance shown in Figure 2;
- Figure 5 is a side view of the appliance when closed;
- Figure 6 is a detailed view of the measurement device as mounted on the appliance shown in Figure 4;
- Figure 7 is an internal view of a lateral arm of the appliance;
- Figure 8 is a side view of the rocker;
- Figure 9 is a perspective view of the appliance in another embodiment;
- Figures 10A, 10B and 11 are schematic views of other embodiments of the measurement device of the invention;
- Figure 12 shows the measurement device of the invention in more detail;
- Figures 13 and 14 show the engagement means of the rocker and of the lateral arm;
- Figure 15 shows another variant of the rocker;
- Figure 16 is a detailed view of a portion of the potentiometer;
- Figure 17 is a perspective view of another variant of the potentiometer shown in Figure 16;
- Figure 18 is a detailed view of another embodiment of the measurement means; and
- Figure 19 shows a portion of the potentiometer.

4. Detailed description

Figure 1 shows a cooking appliance 1 including a first structure 2 that includes a lower heating plate 3 for cooking food and a measurement device 12 for measuring the thickness of the food placed in the appliance 1.

The food may be meat, fish, vegetables, or other foodstuffs.

The measurement device 12 shown in figures 2 to 6, 8, 10A, and 10B to 19 includes a rocker 6 suitable for pivoting in the appliance 1. The rocker 6 has a first end 7 and a second end 8, the first end 7 being connected to a pivoting shaft 9 that is mounted to pivot about an axis of rotation A.

The rocker 6 may be connected rigidly to the shaft 9, e.g. by being mounted in a tight-fitting manner around it. In this way, when the shaft 9 rotates or pivots, it also drives the rocker 6 in rotation so that said rocker pivots. It is also possible to make provision for the rocker 6 to be mounted on the shaft 9 with sufficient clearance to enable the rocker to pivot or rotate about said shaft. Unlike in the variant in which the rocker is mounted rigidly, when the shaft 9 rotates, the

rocker pivots via other means connected to the shaft 9 that are described at a later stage of the description below.

The measurement device 12 also includes measurement means 10 for measuring the angle through which the rocker 6 pivots so as to estimate the thickness of the food, which measurement means are described below.

Provision is made for the appliance 1 to be provided with a second structure 4 that is mounted to move relative to the first structure 2 so that it moves away from said first structure.

The second structure 4 also includes a heating plate, namely an upper heating plate 5, which is adapted to cook the food against it by conduction while said food is disposed between the lower and upper heating plates 3,5. More precisely, the food is cooked against the two heating plates 3, 5.

In a variant, the second structure 4 may be constituted by a lid, for example, for covering the first structure 2.

For example, each structure 2, 4 may be formed by a shell and may have sides 11. For example, the shell may be made of metal or of a polymer. On its shell, the second structure 4 may be provided with a handle 46, preferably made of a thermoplastic and insulating, so as to enable the appliance 1 to be opened and closed. The first structure 2 may be provided with legs 45 for positioning the appliance 1 on a flat surface, for example. The legs 45 may be formed by being integrally moulded with the shell of the second structure 4, or they may be fastened to the shell using screws, or other suitable means. A leg 45 is covered with a wall 56. A cooking juice collection tray 53 may also be provided.

The first and second structures 2, 4 have a closed state in which they each extend in a substantially horizontal plane P and substantially parallel to each other, and an open state in which they substantially form, for example, an L-shape in which they are spaced apart by an angle of about 100° (when the second structure 4 is fastened rigidly to the shaft 9, figure 9). The food to be cooked is thus disposed horizontally between the lower and upper heating plates 3, 5.

Each heating plate 3, 5 is heated by an electrical resistance (not shown) that supplies it with the energy necessary for cooking the food. The electrical resistance is generally situated between the shell and the heating plates 3, 5. The heating plates 3, 5 are preferably removable and may be coated with a non-stick coating.

According to the invention, the second structure 4 moving away from the first structure 2 causes the shaft 9 to rotate relative to the first structure 2, thereby causing the rocker 6 to pivot. When the rocker 6 is fastened rigidly to the shaft 9, the rotation of the shaft 9 causes the rocker 6

to pivot. The measurement means 10 interact with the rocker in the vicinity of the second end 8 of the rocker 6.

The second structure 4 may be mounted on the shaft 9 by means of lateral arms 13 (figure 7) that are mounted to move relative to at least the first structure 2. More precisely, each lateral arm 13 comprises a first end 14 connected to the shaft 9 and a second portion 15 connected to one side 11 of the second structure 4, in the vicinity of the middle 16 of said side. The second portion 15 may be formed by a second end 47 of the lateral arm 13. In this embodiment, said second end 47 is secured to the handle 46.

More precisely, and as can be seen in figure 12, the first end 14 of each of the lateral arms 13 is provided with an opening 17, the inside surface of which is provided with flat surfaces 18, namely two flat surfaces in this example, that are designed to co-operate with the end 19 of the shaft 9 that is also provided with a flat surface 20 in order to create a fixed connection between the shaft 9 and the lateral arms 13. The resulting assembly may be secured even more tightly by a screw 48 via the opening 17 in the lateral arm 13 and via an opening 49. To facilitate guiding of the lateral arm, the wall 56 covering the leg 45 may be provided with a groove or slot 55 in which a stud 54 slides. The second portion 15 of the lateral arm 13 is provided with an opening 21 through which, for example, a screw 22 can pass that is screwed into the middle 16 of the side 11 of the second structure 4. Said screw may be fixed relative to the lateral arm 13 or preferably movable in rotation via a pivot connection created by the screw 22 and by the opening 21. A pivot connection enables the second structure 4 to be adjusted to come substantially parallel to the first structure 2 so that the food is cooked uniformly. However, movement of the second structure 4 relative to the lateral arm 13 may be inhibited by means of a male member, of the trunnion or lug type, mounted on the shell of the structure 4 co-operating with a female member, of the notch type, provided in the inside face of the lateral arm 13, and suitable for defining an obstacle connection.

In a variant of the appliance 1, shown schematically in figure 9, it is possible for said appliance not to have lateral arms 13. In which case, it is the movement of the second structure 4, which is mounted in a tight-fitting and rigid manner on the shaft 9, that causes the rocker 6 to pivot.

As explained above, the rocker 6 may be connected rigidly to the shaft 9. For this purpose, the first end 7 of the rocker 6 is provided with an orifice 23, the inside surface of which may be provided with a flat surface (not shown) that comes to face the flat surface 20 on the shaft 9 to create a fixed connection. However, the rocker 6 may be mounted in a tight-fitting manner via the fastening of the lateral arm 13 to the shaft 9. In this way, on causing the lateral arms 13 and/or the

second structure 4 to pivot to open the appliance 1, the shaft 9 is caused to rotate, thereby simultaneously causing the rocker 6 to move.

The rocker 6 has a length of about 100 mm. For example, said rocker may be made of plastic, of metal, or of some other material.

5 The first end 7 of the rocker 6 may be engaged with the first end 14 of one of the lateral arms 13 where the rocker 6 is connected to the shaft. The engagement between the rocker 6 and the lateral arm 13 is obtained by means of a first finger 25 situated on the outside face 24 of the first end 7 of the rocker 6. The first finger 25 enables a rear portion 50 of the lateral arm 13 to bear against it while the lateral arm 13 is moving. For example, this engagement is established until the
10 lateral arm 13 has pivoted through a predetermined pivot angle α (see figure 4), the lateral arm disengaging from the rocker 6 once said lateral arm pivots beyond said predetermined angle α , so that the lateral arms 13 then continue to pivot, towards a fully open position of the lateral arms 13 and/or of the first and second structures 2, 4, without the rocker 6 continuing to pivot.

When the rocker 6 is mounted with a clearance on the shaft 9, said shaft is mounted rigidly
15 with the lateral arm 13. In particular, the mounting is achieved by means of the flat surface 20 on the shaft 9 co-operating with the flat surface 18 on the inside surface of the opening 17 of the lateral arm 13. The stud 54 provided on the lateral arm 13 is advantageously designed to come into contact with the first finger 25 with which the rocker 6 is provided. By causing the lateral arm 13 to pivot, the stud 54 is caused to come into abutment against the first finger 25, thereby causing the
20 rocker 6 to rotate i.e. to pivot. In order for the lateral arms 13 and/or the first and second structures 2, 4 to continue pivoting towards the fully open position, it is possible to make provision for the stud 54 to be constituted by a flexible blade. Said blade would enable the lateral arm 13 to be disengaged from the rocker 6 when the lateral arm pivots beyond its predetermined pivot angle α . Other solutions are naturally possible for enabling the lateral arm 13 and the rocker 6 to
25 be disengaged from each other.

The predetermined pivot angle α of the lateral arm 13 corresponds to a predetermined pivot angle β of the rocker 6 that lies in the range from 10° to 30° (shown in Figure 4). Preferably, the predetermined pivot angle β of the rocker 6 is about 24° . More precisely, the predetermined pivot angle β of the rocker 6 corresponds to an intermediate open state of the first and second
30 structures 2, 4 and/or of the lateral arms 13, in which state said structures 2, 4 are spaced apart in such a manner as to be substantially parallel to each other. In their intermediate open state, the first and second structures 2, 4 then have a gap or spacing between them that lies in the range from 30 mm to 60 mm. Preferably, this spacing is 40 mm.

At its second end 8, the rocker 6 is provided with means for interacting with the measurement means.

More precisely, on its inside face 51, the second end 8 of the rocker 6 may be provided with a second finger 26 that is designed to establish a connection between the rocker 6 and actuation means 60 for actuating the measurement means 10.

For example, the measurement means 10 may comprise a potentiometer 27, a strain gauge, an optical detection system 29 with a photodetector, or an electromagnetic detection system. The measurement means 10 are preferably installed in one of the rear legs 45 so as to avoid temperature variations.

In the embodiment comprising the potentiometer 27, said potentiometer includes a body 59 and a cavity 36 opening out into the body 59. The potentiometer 27 also includes a lever 30 that is driven by the second finger 26 of the rocker 6 while the first and second structures 2, 4 are moving from their closed state to their intermediate open state.

Advantageously, the measurement means 10 further comprise biasing means 32.

In particular, the lever 30 has a distal end 31 that can be biased by the biasing means 32 that keep the rocker 6 and the lever 30 in contact with each other, at the second finger 26, while, for example, the second structure 4 is moving away from the first structure 2, or while the lateral arms 13 are moving. The biasing means 32 may be fastened via one of their ends 33 to the frame of the appliance 1 and via their other end 33 to a passage 52 with which the distal end 31 of the lever 30 may be provided.

The lever 30 may also have a proximal end 34 provided with a head 35 that is designed to engage in the cavity 36 of the potentiometer 27. The lever 30 is mounted to rotate through an angle θ lying in the range 0° to 65° . The lever may have a length of about 20 mm.

As shown in figures 15 to 19, in another variant of this embodiment, the measurement means 10 comprise the potentiometer 27. The potentiometer includes a toothed wheel 57 installed inside the body 59 of the potentiometer 27. However, a portion of the toothed wheel 57 remains accessible outside the body 59. More precisely, the toothed wheel 57 is driven by a rack 58 with which the end 8 of the rocker 6 is provided. The teeth of the wheel may be disposed over all or some of the periphery of said wheel. The biasing means 32 may be housed inside the body 59 of the potentiometer so as to keep the rocker 6 and the lever 30 in contact with each other during the separation movement of the second structure 2.

The biasing means 32 may comprise a first return element 61 and a second return element 62. The first return element 61 may be housed in the measurement means 10, e.g. in the

body 59 of the potentiometer 27 and/or the second return element 62 may be fastened firstly to the frame and secondly to the distal end 31 of the lever 30.

These biasing means 32 make it possible to return the rocker 6 when it is released on full opening of the appliance 1, and they mitigate the problem of manufacturing-related clearance.

5 They are preferably constituted by a traction spring and/or a spiral spring.

The potentiometer 27 may be used in non-limiting manner. It may have an angular range extending from 0° to 90°, from 0° to 120°, or indeed from 0 to 360°. Provision may be made for the potentiometer 27 to be provided with a printed circuit that is integrated into it, adjoined to it, or offset from it.

10 In the embodiment comprising the strain gauge 28 that is shown in figures 10A and 10B, said strain gauge is disposed, for example, on a wall 37 of the rear leg 45. The second end 8 of the rocker 6 is provided with a recess having an opening 38 and in which a needle 39 is received that passes through the opening 38 while the rocker 6 is pivoting. The needle 39 is mounted on a spring 40 and acts on the strain gauge 28.

15 Figure 11 schematically shows an example of an optical detection system with a photodetector and comprising a light-emitting diode (LED) 41 and a photodetector 42 that are, for example disposed remotely on the frame, inside the leg 45. A reflective element 43 may be mounted on the second end 8 of the rocker 6 to reflect the light ray towards the photodetector 42, thereby making it possible to estimate the thickness of the food.

20 As regards the electromagnetic elements that are provided for the measurement means, they may, for example, be constituted by a Hall effect sensor.

By means of the arrangement of the measurement device 12, it is possible to establish a ratio of amplification of the rocker pivot angle β (or of the angle of the lateral arm 13) that is greater than 3 to make it possible to differentiate between thicknesses of food at +/- 1 mm. This ratio can
25 be written as follows:

$$R_{\text{amplification}} = \frac{L_{\text{swing arm}}}{L_{\text{lever}}} = \frac{\beta_{\text{lever}}}{\alpha_{\text{swing arm}}} > 3$$

30 In order to optimize the achieved results so that they are accurate, and for better cooking of the food, it is possible to make provision to calibrate the appliance 1 in the factory, after manufacture. For greater accuracy such calibration consists in measuring the same magnitude with the appliance with gauge blocks.

For example, a first gauge block designed to simulate a food thickness may be installed between the first and second structures 2, 4 so as to obtain a first value or "first point". The first block may have a thickness of about 2 mm.

5 A second gauge block is then disposed between the first and second structures 2, 4 in order to obtain a second value or "second point". The second block may have a thickness of about 30 mm.

The first and second points make it possible, through various simulations, to determine the uncertainties related to the measurements taken by the appliance 1 during the calibration, and, naturally, to correct them.

When the appliance is sold and ready to operate, a user can use it as follows:

10 - Switching on the appliance 1 by pressing, for example, on an on/off button or key of an interface 44 with which the appliance 1 is provided. For example, the appliance may be switched on by plugging in a power cord that it has in order to connect it to the mains power supply.

- If provision is made to do so, selecting the type of food by means of the interface 44.

- Also if provision is made to do so, selecting a desired degree of cooking for the food.

15 Otherwise it is possible make provision for the appliance 1 to determine cooking temperatures as a function of the food.

- Also if provision is made to do so, automatically determining the preheat temperature for the appliance 1.

20 - Opening the appliance. This step may be performed at any time during the above-mentioned steps.

- Putting the food in place.

- Closing the appliance 1 by lowering the second structure 4 and/or the lateral arms 13 onto the food.

25 - This step enables the appliance 1 to take the measurements for measuring the thickness of the food then disposed between the first and second structures 2, 4, and, for example, to initiate the cooking of the food. Said measuring of thickness is obtained automatically by the pivot angle β of the rocker 6. The rocker makes it possible to determine the spacing between the first and second structures 2, 4 in order to estimate the thickness of the food.

30 - Once the food is cooked, the user can retrieve the food or leave it to keep it warm between the structures 2, 4.

- The appliance can be switched off by selecting the on/off key or be unplugged.

The interface 44 may have various keys or buttons that make it possible to access a menu, or it may have a touch screen.

In order to make sure that the mechanical and/or electronic system of the appliance 1 operates optimally and in order to compensate for all of the errors and uncertainties that occur after the appliance 1 has been used several times or after it ages, provision may be made for the user to perform automatic adjusting of the appliance 1. This adjustment is preferably performed while the grill is closed. The adjustment is intended to return the measurement device 12 to an operating state that is suitable for it to be used. For example, with the grill closed, the device is reset to 0, i.e. the value indicating that there is no thickness of food in the appliance 1.

For example, the user may, prior to use, press on an adjustment key or press on a combination of keys to obtain the adjustment.

Patentkrav**1. Tilberedningsapparat (1) omfattende:**

- 5 - en første struktur (2) omfattende en varmeplade (3) til tilberedning af en fødevare; og,
- en anden struktur (4), der er bevægelig i forhold til den første struktur (2), til at fremkalde en adskillelsesbevægelse, hvor adskillelsesbevægelsen i den anden struktur resulterer i drejning af en aksel (9), som kan dreje i forhold til den første struktur (2),

10 kendetegnet ved, at det omfatter:

en måleindretning (12) til at måle tykkelsen af den således anbragte fødevare, hvilken måleindretning omfatter:

- 15 ▪ en svingarm (6) der er i stand til at dreje i indretningen, idet svingarmen omfatter en første ende (7) og en i længderetningen modstående anden ende (8), idet svingarmen (6) med sin første ende (7) er forbundet med akslen (9); og
▪ et organ (10) til at måle svingarmens (6) drejningsvinkel for at bedømme fødevarens tykkelse; idet måleorganet samvirker med svingarmen (6) hen mod den anden ende af svingarmen (6),
20 idet adskillelsesbevægelsen af den anden struktur i forhold til den første struktur (2) resulterer i drejning af svingarmen (6).

2. Apparat (1) ifølge krav 1, kendetegnet ved, at den anden struktur (4) omfatter en varmeplade (5) indrettet til at tilberede fødevaren, der er anbragt mod denne mellem pladerne (3, 5), ved varmeledning.

3. Apparat (1) ifølge krav 1, kendetegnet ved, at svingarmen (6) er stift forbundet med den drejelige aksel (9).

30 **4. Apparat (1) ifølge krav 1, kendetegnet ved, at svingarmen (6) er monteret på akslen (9) med et spillerum der er tilstrækkeligt til at tillade at svingarmen (6) drejer.**

5. Apparat (1) ifølge krav 1 eller 2, kendetegnet ved, at den anden struktur (4) er anbragt på akslen (9) ved hjælp af laterale arme (13) der er bevægelige i det

mindste i forhold til den første struktur (2).

6. Apparat (1) ifølge krav 5, **kendetegnet ved**, at hver lateral arm (13) omfatter en første ende (14), der er forbundet med akslen (9), og en anden del, der er
5 (15) forbundet med en side (11) af den anden struktur (4) hen imod midten (16) af siden (11).

7. Apparat (1) ifølge krav 5, **kendetegnet ved**, at den første ende (7) af svingarmen (6) er i indgreb med en første ende (14) af en af de laterale arme
10 (13) hvor armen (13) er forbundet med akslen (9), idet dette indreb virker indtil en forudbestemt drejningsvinkel på armene (13), hvorefter armen (13) frigøres fra svingarmen (6), således at de laterale arme (13) derefter fortsætter deres drejning uden at svingarmen (6) fortsætter med at dreje.

15 8. Apparat (1) ifølge krav 7, **kendetegnet ved**, at den forudbestemte drejningsvinkel for armene (13) svarer til den forudbestemte drejningsvinkel (β) for svingarmen (6) som er på mellem 10° og 30° .

9. Apparat (1) ifølge krav 7 eller 8, **kendetegnet ved**, at den forudbestemte
20 drejningsvinkel (β) for svingarmen (6) svarer til en mellemliggende åbningstilstand for den første (2) og anden struktur (4), hvor den første og anden struktur i det væsentlige er parallelle.

10. Apparat (1) ifølge et af kravene 1 til 9, **kendetegnet ved**, at svingarmen (6)
25 mod dens anden ende (8) er forbundet med et aktiveringsorgan (60) til at aktivere måleorganet (10).

11. Apparat (1) ifølge kravene 1 til 10, **kendetegnet ved**, at måleorganet (10) omfatter et potentiometer (27).

30

12. Apparat (1) ifølge krav 10 eller ifølge kravene 10 og 11, **kendetegnet ved**, at svingarmen omfatter første (25) og anden (26) fingre, aktiveringsorganet (60) omfatter en arm (30), der bevæges af den anden finger (26) på svingarmen (6) og er forspændt ved hjælp af et forspændingsorgan (32) der holder svingarmen
35 (6) og stangen (30) i kontakt under adskillelsesbevægelsen af den anden struktur

(2).

13. Apparat (1) ifølge krav 10 eller ifølge kravene 10 og 11, **kendetegnet ved, at** aktiveringsorganet (60) omfatter et tandhjul (57), der drives af en tandstang 5 (58) på svingarmen (6) og er forspændt ved hjælp af mindst et forspændingsorgan (32) der holder svingarmen (6) og tandhjulet (57) i kontakt under adskillelsesbevægelsen af den anden struktur (2).

14. Apparat (1) ifølge et af kravene 1 til 10, **kendetegnet ved, at** måleorganet 10 (10) omfatter en af en deformationsmåler (28) eller et optisk detekteringssystem (29) med en fotodetektor.

15. Fremgangsmåde til anvendelse af apparatet (1) ifølge et hvilket som helst af kravene 1 til 14, hvilket apparat omfatter en første struktur (2), der omfatter en 15 varmeplade til tilberedning af fødevarer, **kendetegnet ved, at** fremgangsmåden omfatter et trin til justering af apparatet (1) inden anvendelse, hvor brugeren vælger en tast eller en kombination af taster omfattet af apparatet (1).

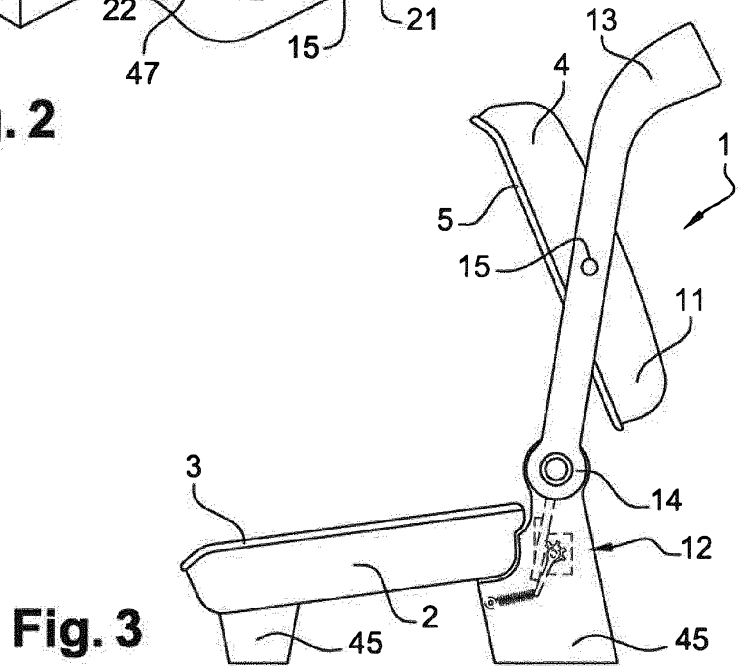
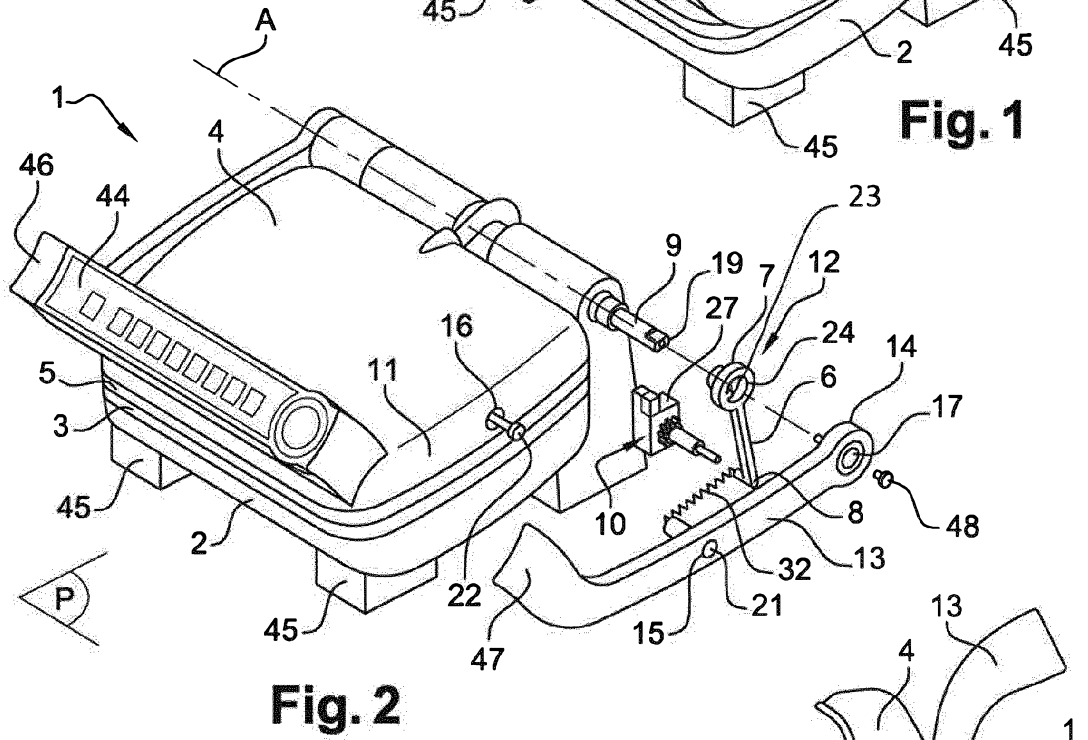
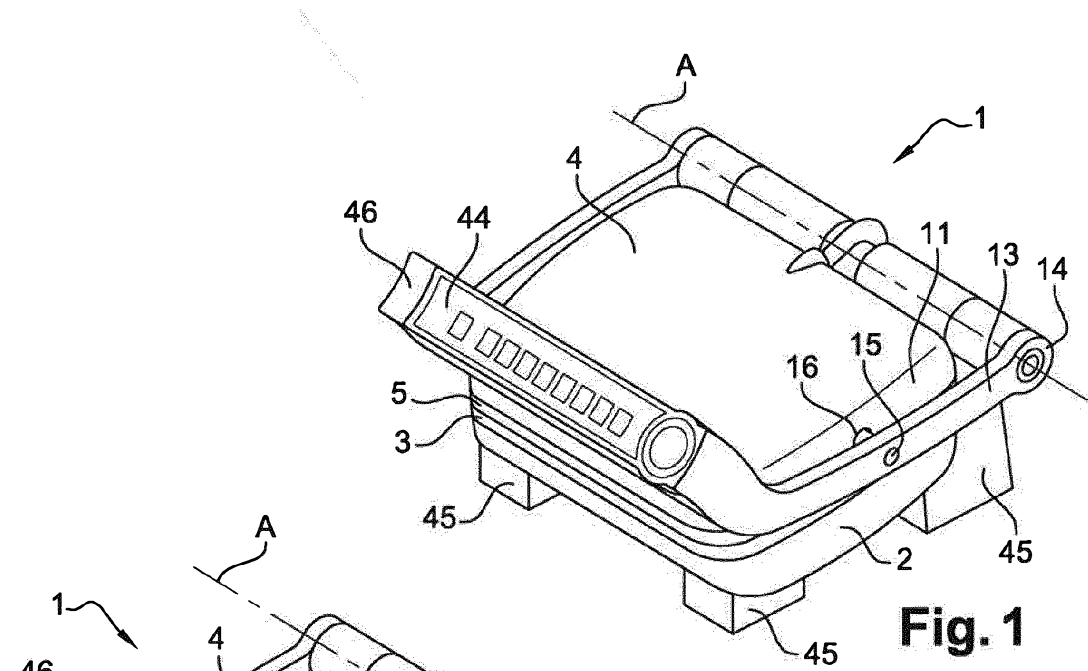

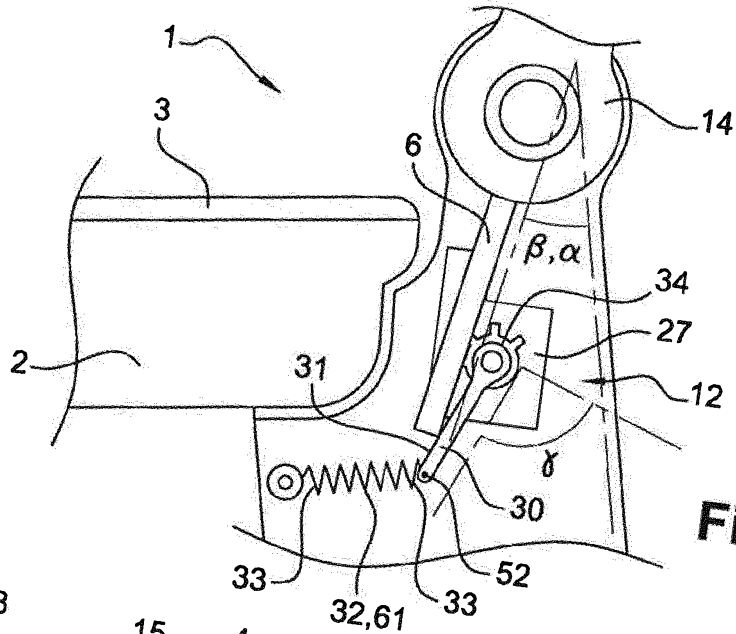

Fig. 4

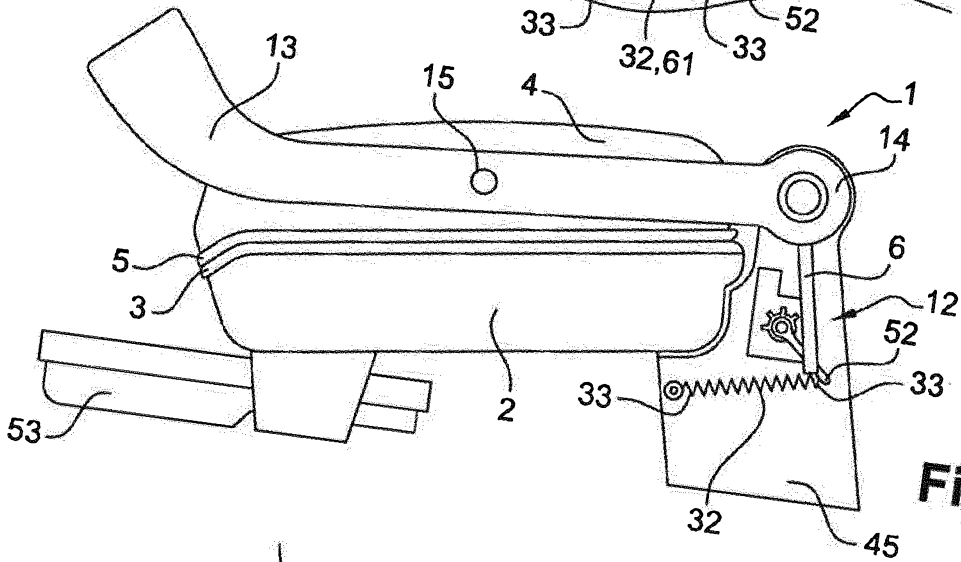

Fig. 5

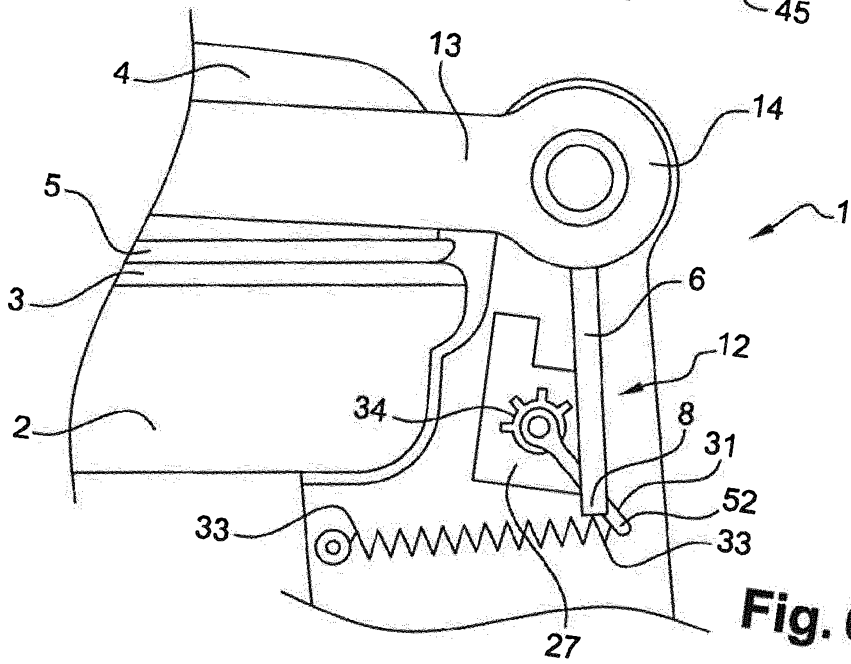
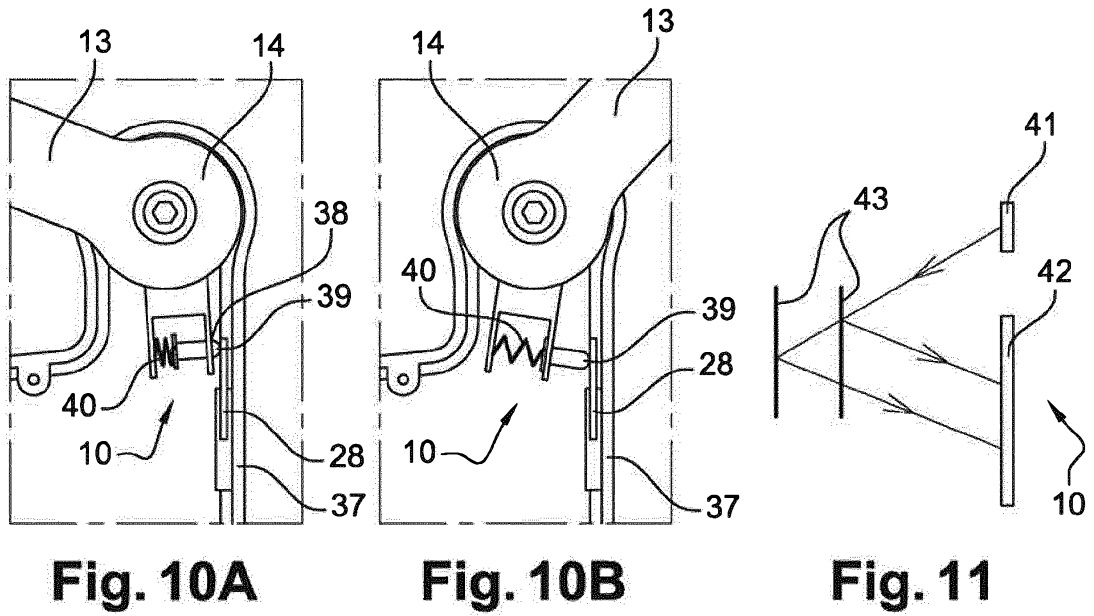
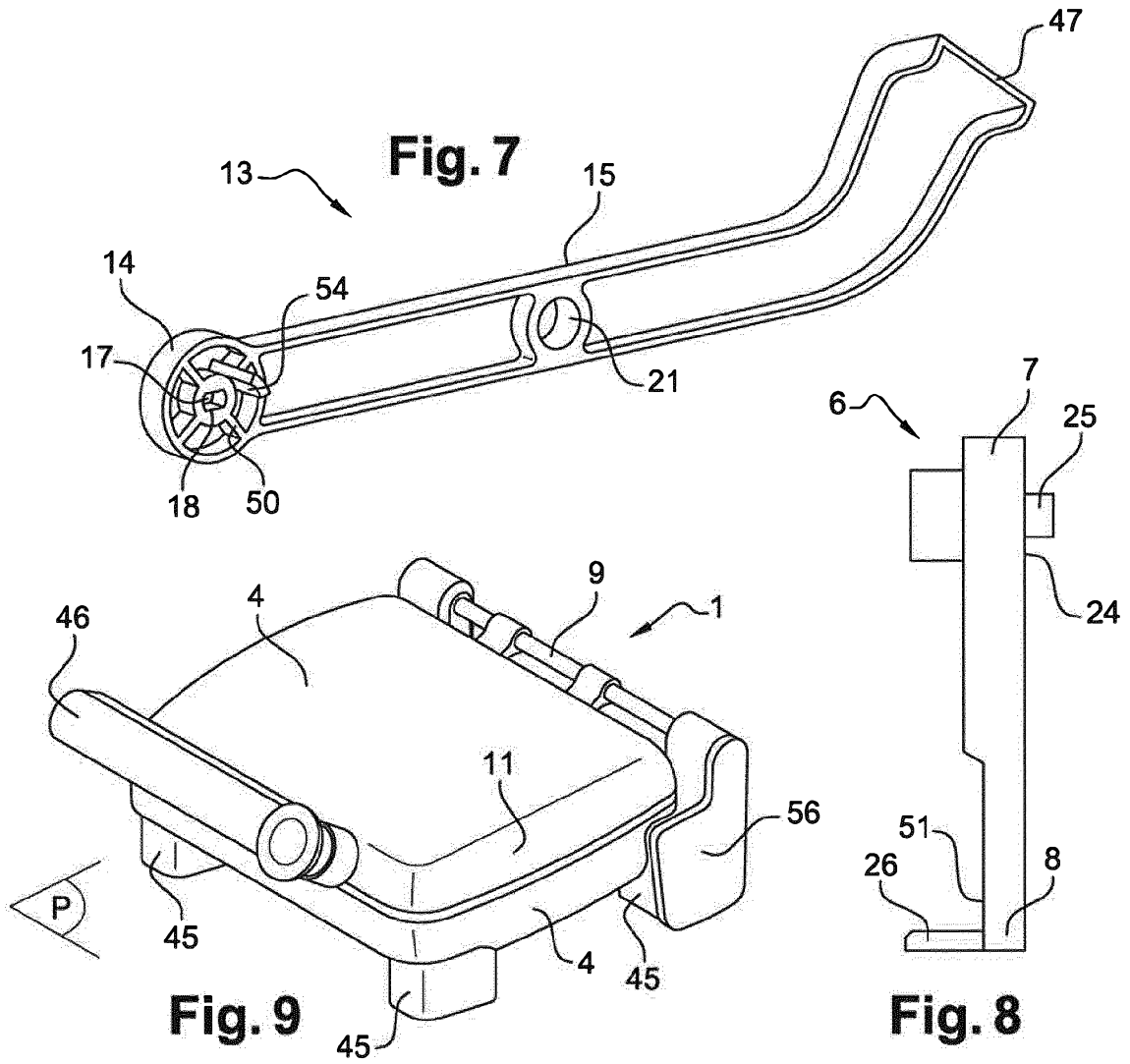

Fig. 6



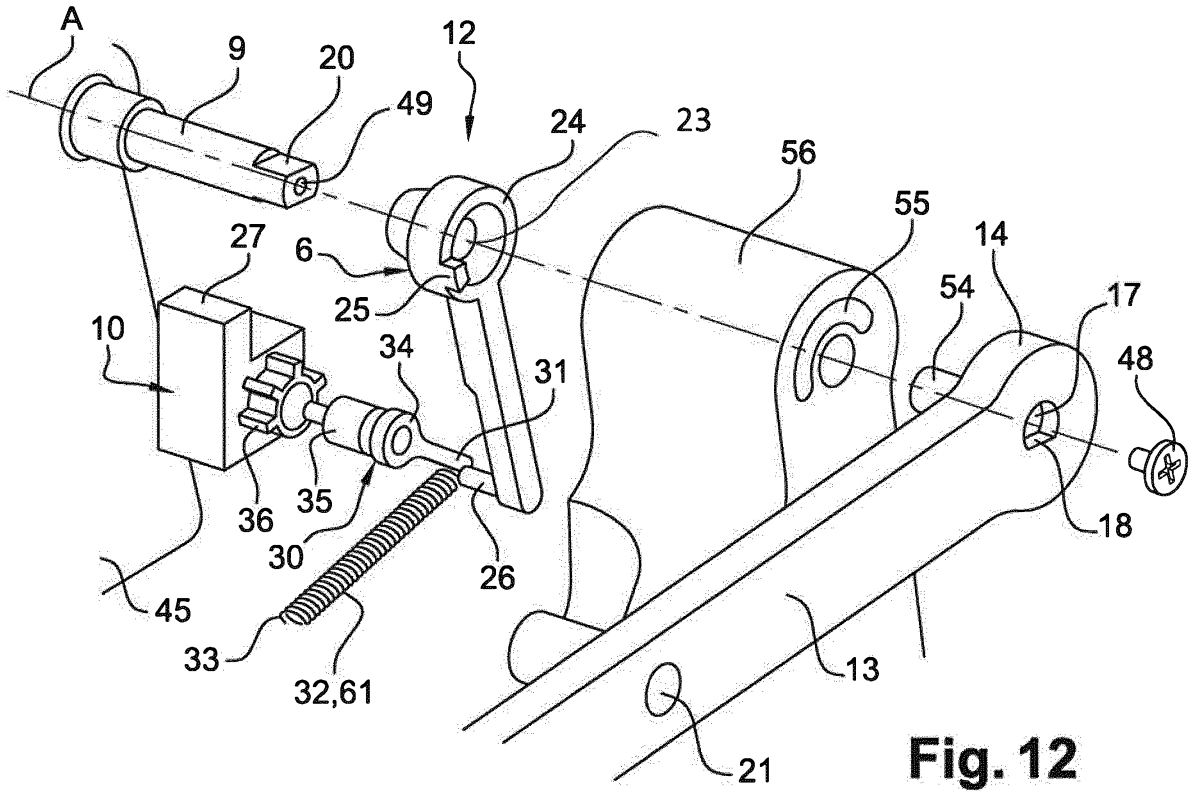

Fig. 12

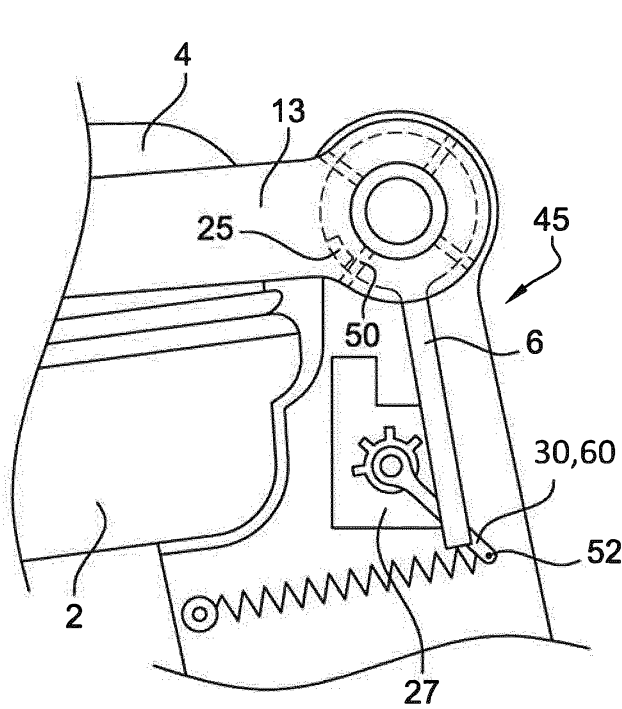

Fig. 13

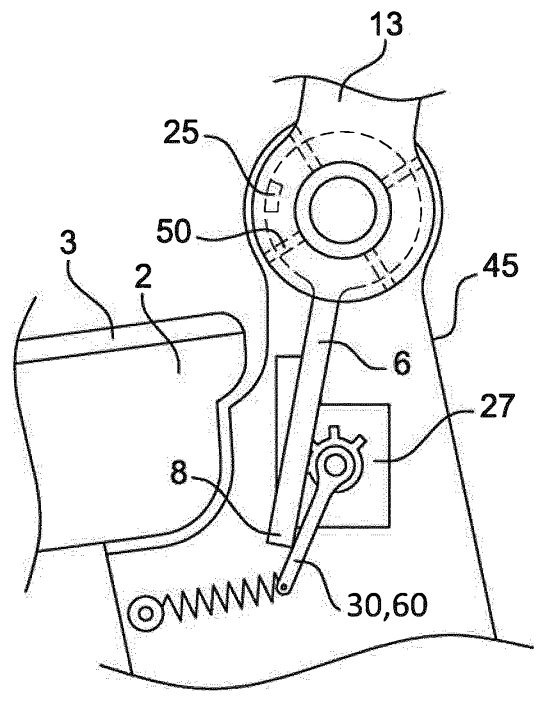

Fig. 14

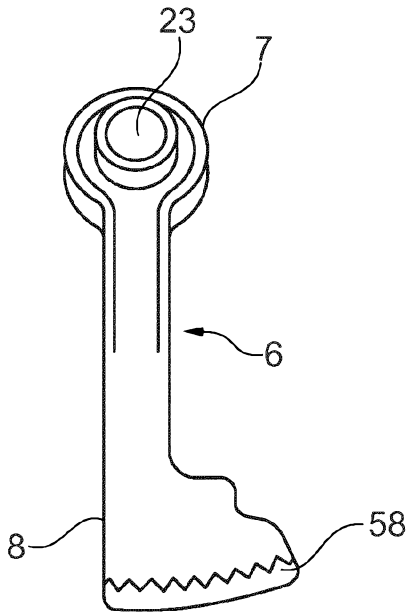

Fig. 15

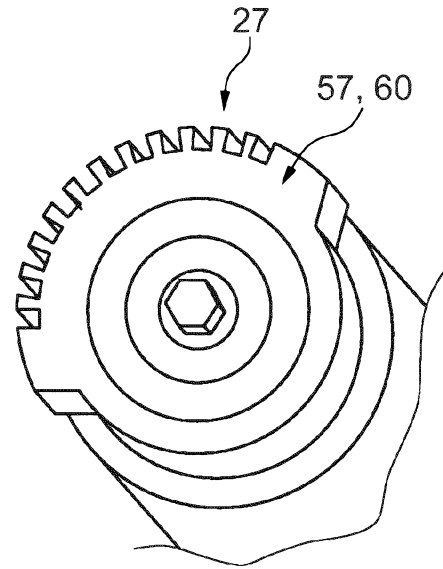

Fig. 16

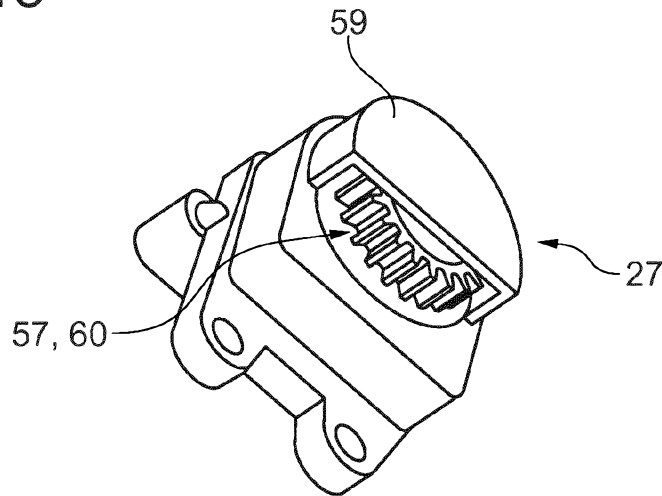

Fig. 17

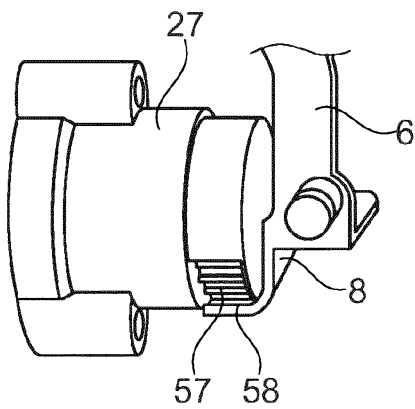

Fig. 18

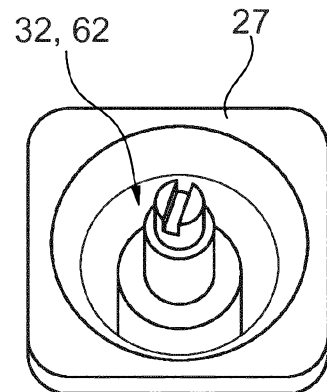

Fig. 19