



US 20220155280A1

(19) **United States**

(12) **Patent Application Publication**

Krenz et al.

(10) **Pub. No.: US 2022/0155280 A1**

(43) **Pub. Date: May 19, 2022**

(54) **SYSTEMS AND METHODS FOR COLLECTING A BIOLOGICAL SAMPLE FROM A PASSENGER CABIN**

63/114,386, filed on Nov. 16, 2020, provisional application No. 63/114,400, filed on Nov. 16, 2020.

Publication Classification

(71) Applicant: **Koninklijke Fabriek Inventum B.V.**, Nieuwegein (NL)

(51) **Int. Cl.**
G01N 33/497 (2006.01)
B64D 13/08 (2006.01)

(72) Inventors: **Michael Krenz**, Roscoe, IL (US);
Arnau Castillo Gonzalez, Maarsse (NL)

(52) **U.S. Cl.**
CPC **G01N 33/497** (2013.01); **H04L 67/12** (2013.01); **G01N 2033/4975** (2013.01); **B64D 13/08** (2013.01)

(73) Assignee: **Koninklijke Fabriek Inventum B.V.**, Nieuwegein (NL)

(57) **ABSTRACT**

(21) Appl. No.: **17/518,458**

A system for collecting a biological sample from a passenger cabin includes a collector for collecting particulate samples positioned within at least one of an outlet flow path or a recirculation flow path. The system includes at least one of an outflow valve positioned in the outlet flow path downstream from the collector or a HEPA (high efficiency particulate air) filter positioned in the recirculation flow path downstream from the collector. A method for collecting particulates from cabin air includes capturing particulates in at least one of an outlet flow path or a recirculation flow path with a collector for a period of time, removing the collector from at least one of the outlet flow path or the recirculation flow path for testing, and inserting a clean collector into at least one of the outlet flow path or the recirculation flow path for use during another period of time.

(22) Filed: **Nov. 3, 2021**

Related U.S. Application Data

(60) Provisional application No. 63/114,330, filed on Nov. 16, 2020, provisional application No. 63/114,339, filed on Nov. 16, 2020, provisional application No. 63/114,350, filed on Nov. 16, 2020, provisional application No. 63/114,064, filed on Nov. 16, 2020, provisional application No. 63/114,366, filed on Nov. 16, 2020, provisional application No. 63/114,157, filed on Nov. 16, 2020, provisional application No.

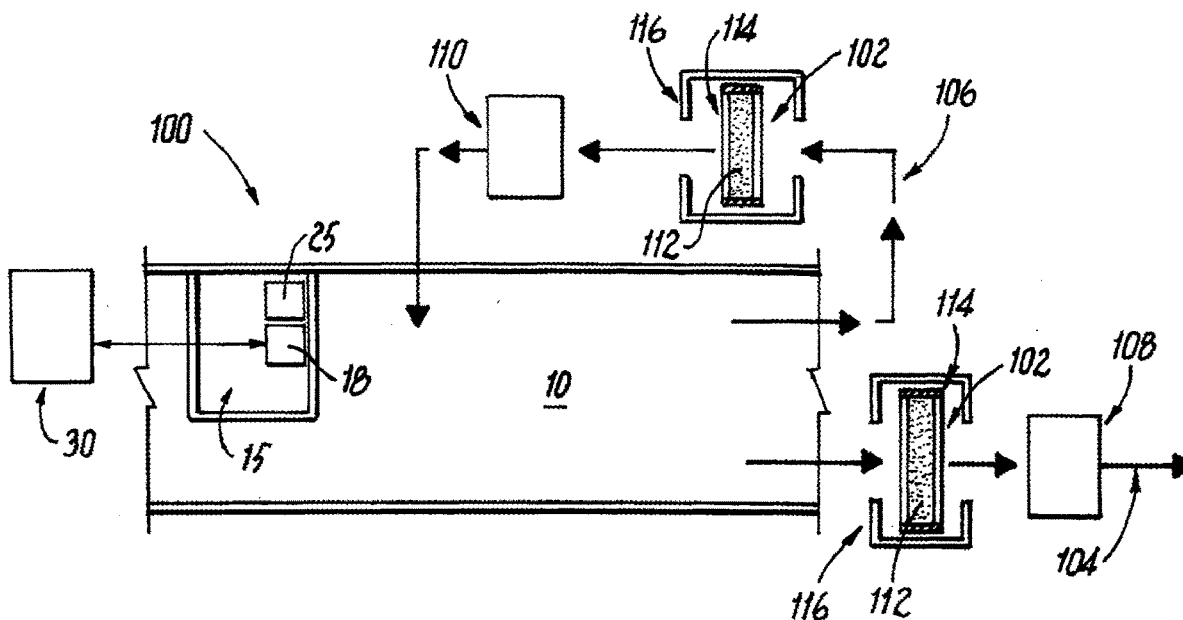

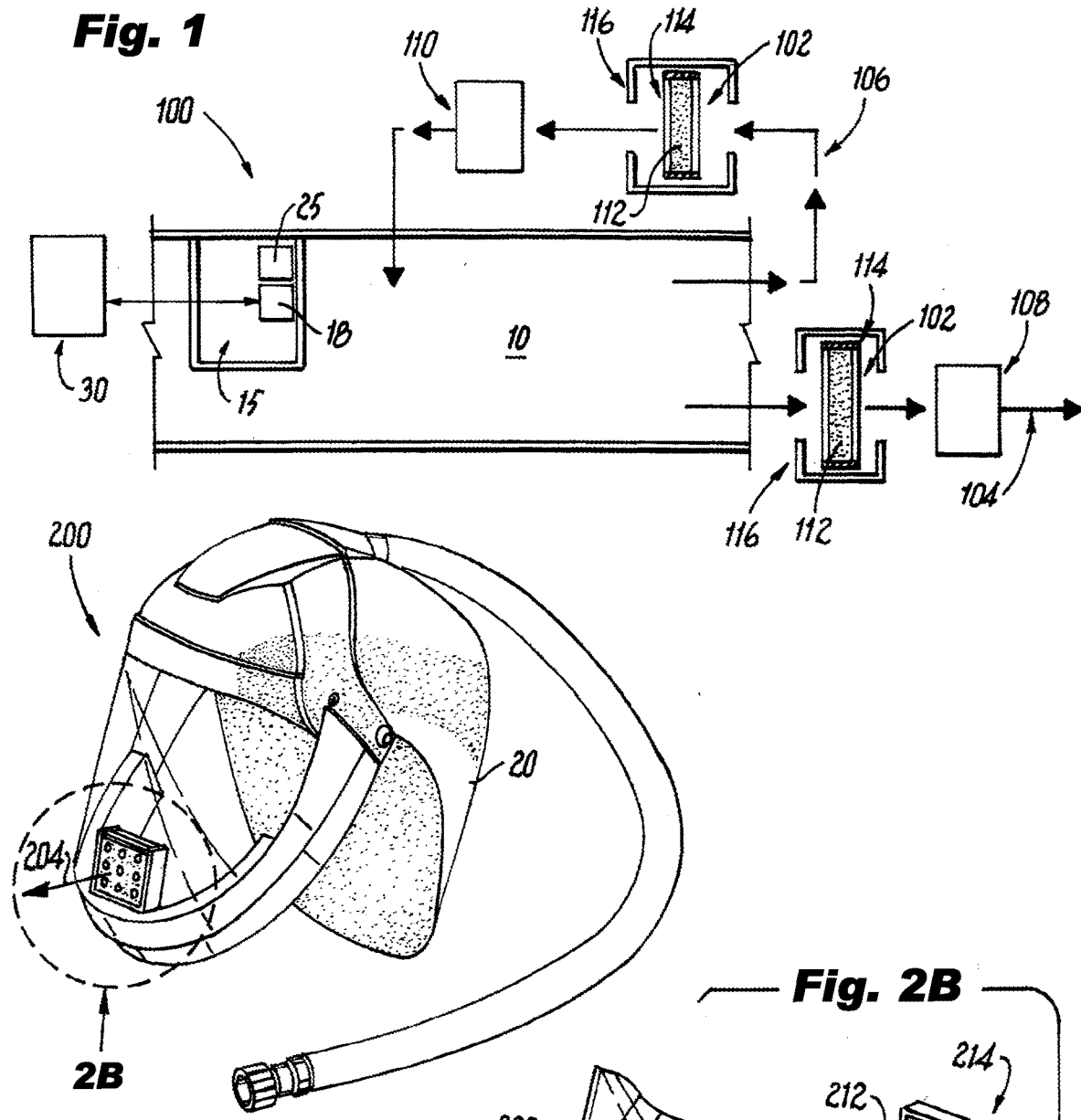

Fig. 2A

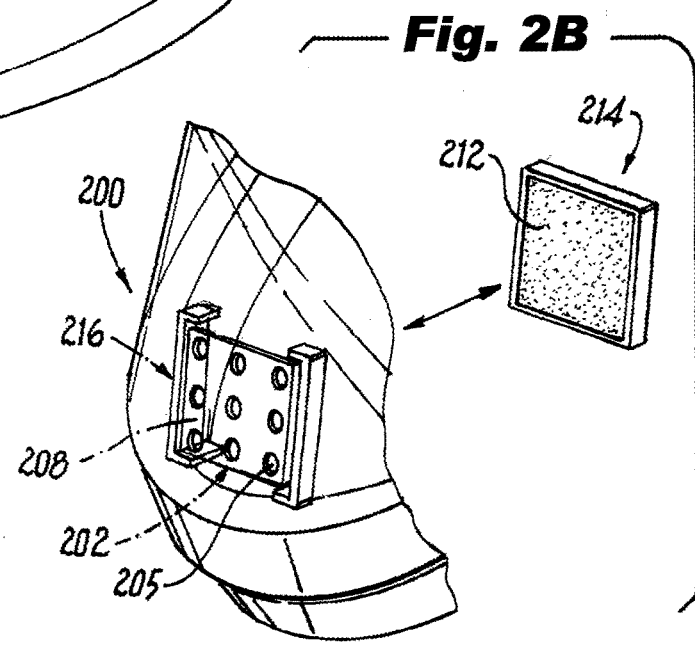

Fig. 2B

SYSTEMS AND METHODS FOR COLLECTING A BIOLOGICAL SAMPLE FROM A PASSENGER CABIN

CROSS-REFERENCE TO RELATED APPLICATION

[0001] This application claims priority to U.S. Provisional Patent Applications with the following Ser. Nos. 63/114,330, 63/114,339, 63/114,350, 63/114,400, 63,114,064, 63/114,157, 63/114,386, 63/114,366 all filed on Nov. 16, 2020. This application is related to Patent Application Ser. No. 63/043,414 filed on Jun. 24, 2020. The contents of each of the aforementioned Provisional Applications are herein incorporated by reference in their entirety.

BACKGROUND OF THE INVENTION

1. Field of the Invention

[0002] The present disclosure relates to collecting a biological sample and more particularly to systems and methods for collecting a biological sample representative of a passenger cabin on an aircraft using a collector.

2. Description of Related Art

[0003] The spread progression of SARS-CoV-2 around the world has brought attention to the systemic risks of economic globalization. As a result of the COVID-19 pandemic there is a need for better monitoring, detecting, and isolating ill passengers, specifically due to the detrimental impact on the global economy, to prevent the spread of COVID-19 and other pathogens during travel, e.g. air travel, rail travel or the like, due to closed borders, movement restrictions, and testing requirements.

[0004] The COVID-19 pandemic the air travel industry has proven that air travel can be safe and that aircraft cabins have a well-managed airflow that inhibits transmission of virus, and that being seated onboard an aircraft is safer than shopping in large stores. Governments and other authorities, however, need to assume that aircraft are contaminated until proven “clean”, as 25% of COVID-19 cases are asymptomatic or pre-symptomatic; but still contagious. To date, travelers and governments have relied on individual tests. Testing for viruses requires that samples be taken of various bodily tissues and/or fluids. An adequate concentration of material is needed, the concentration being determined by the type and sensitivity of the testing procedure. It could be difficult to get adequate samples from travelers for the purposes of virus detection, contact tracing in the event of an exposure, etc. It is also possible that the airline is required to certify the arriving aircraft as being “virus free”.

[0005] The conventional techniques have been considered satisfactory for their intended purpose. However, there is an ever present need for improved monitoring, detecting, and isolating systems and methods. This disclosure provides a solution for this need.

SUMMARY

[0006] A system for collecting a biological sample from a passenger cabin includes a collector for collecting particulate samples positioned within at least one of an outlet flow path or a recirculation flow path. The system includes at least one of an outflow valve positioned in the outlet flow path downstream from the collector or a HEPA (high efficiency

particulate air) filter positioned in the recirculation flow path downstream from the collector.

[0007] The collector can include a filter material. The HEPA filter can be configured and adapted to clean air flowing through the recirculation flow path. The particulate samples can include droplets exhaled from passengers throughout a duration of a flight. The collector can include an adaptor and a filter material operatively connected to the adaptor. The adapter can be a frame and the filter material can be mounted to the frame. The system can include a mounting in the outlet flow path upstream from the outflow valve, and the collector can be positioned within the slot. The collector can be configured and adapted to be removed from the slot for testing. The outflow valve can be positioned in a positive pressure mask, and the collector can be positioned across the outlet flow path upstream from the outflow valve to collect individual particulate samples throughout a duration of a flight. The outlet flow path can be a general cabin outlet flow path and the outflow valve can be positioned within the general cabin outlet flow path. The collector can be positioned across the general cabin outlet flow path upstream from the outflow valve to collect a cabin air particulate sample throughout a duration of a flight.

[0008] In accordance with another aspect, a method for collecting particulates from cabin air includes capturing particulates in at least one of an outlet flow path or a recirculation flow path with a collector for a period of time, removing the collector from at least one of the outlet flow path or the recirculation flow path for testing, and inserting a clean collector into at least one of the outlet flow path or the recirculation flow path for use during another period of time.

[0009] The method can include conducting a pathogen identifying test on at least one particulate captured in the collector. The method can include relaying a result of the pathogen identifying test to a central data center. The period of time can be a duration of a flight, and the pathogen identifying test can be done on-board an aircraft after the duration of the flight to determine if the aircraft is virus free upon arrival. The collector can include an adaptor and a filter material operatively connected to the adaptor, and the method can include removing the filter material from the adaptor. The method can include cleaning the adapter in isopropyl alcohol.

[0010] In accordance with another aspect, a system for monitoring aircraft air includes an aircraft galley, a pathogen identifying testing unit within the galley, and a collector fluidly connected to at least one of an outflow valve of a positive pressure mask, or an outflow valve of the aircraft.

[0011] The pathogen identifying test unit can include a communication unit for communicating results remotely. The communication unit can be configured to communicate the results to a destination airport.

[0012] These and other features of the systems and methods of the subject disclosure will become more readily apparent to those skilled in the art from the following detailed description of the preferred embodiments taken in conjunction with the drawings.

BRIEF DESCRIPTION OF THE DRAWINGS

[0013] So that those skilled in the art to which the subject disclosure appertains will readily understand how to make and use the devices and methods of the subject disclosure without undue experimentation, preferred embodiments

thereof will be described in detail herein below with reference to certain figures, wherein:

[0014] FIG. 1 is a schematic view of an embodiment of a system for monitoring aircraft air constructed in accordance with the present disclosure, showing collectors positioned downstream from a cabin of an aircraft within an outlet flow path and a recirculation flow path:

[0015] FIG. 2A is schematic view of another embodiment of a system for monitoring aircraft air constructed in accordance with the present disclosure, showing a collector located on a positive pressure mask; and

[0016] FIG. 2B is a perspective exploded view of a portion of the system of FIG. 2A, showing a filter material.

DETAILED DESCRIPTION OF THE PREFERRED EMBODIMENTS

[0017] Reference will now be made to the drawings wherein like reference numerals identify similar structural features or aspects of the subject disclosure. For purposes of explanation and illustration, and not limitation, a schematic view of an exemplary embodiment of a system monitoring cabin air in accordance with the disclosure showing a collector within a cabin of an aircraft is shown in FIG. 1 and is designated generally by reference character 100. Other embodiments of systems in accordance with the disclosure, or aspects thereof, are provided in FIG. 2A-2B as will be described. The systems and methods described herein can be used to provide multiple options for monitoring cabin air. The embodiments of the system for monitoring cabin air of the present disclosure provide systems for collecting particulates on a filter material in any enclosed space such as inside an aircraft cabin, train cabin, or the like, and allows for the detection of a virus or other contaminant by testing the collected particulates.

[0018] As shown in FIG. 1, a system 100 for collecting a biological sample and monitoring cabin air for the cabin 10 of an aircraft 20 includes two collectors 102 for collecting particulate samples. Each collector 102 includes a filter material 112 and an adapter 114, e.g., a frame. The filter material 112 is operatively connected to the adapter 114. The filter material 112 is mounted to the frame 114. A first of the two collectors 102 is positioned in an outlet flow path 104. An outflow valve 108, e.g. a cabin pressurization outflow valve, is positioned in the outlet flow path 104 downstream from the collector 102. The outlet flow path 104 is a general cabin outlet flow path. For aircraft with more than one outflow valve 108, there can be a collector 102 for each valve 108. A mounting slot 116 is located in the outlet flow path 104 upstream from the outflow valve 108. One of the collectors 102 is positioned within the mounting slot 116 of the outlet flow path 104. The collector 102 is positioned across the general cabin outlet flow path 104 upstream from the outflow valve 108 such that the cabin air impinges on the filter material 112 thereby allowing the filter material 112 to collect a cabin air particulate sample throughout a duration of a flight. The collector 102 is configured and adapted to be removed from the mounting slot 116 for testing. The collectors 102, e.g. filter boxes, can be placed in easily accessible locations (near baggage doors, or other access doors) to allow for quick removal and testing upon aircraft arrival. In some embodiments, a collector 102 that tested negative could possibly be placed back in the aircraft for another flight. Assuming that there are no filters between the passengers and the outflow valve 108 to certify the entire

aircraft as virus free, the collector 102 upstream from the outflow valve 108 of the aircraft could likewise be inspected upon arrival. Once tested “clean”, the passengers would be allowed to disembark into a “clean” area of the terminal.

[0019] With continued reference to FIG. 1, a second of the two collectors 102 is positioned within a recirculation flow path 106. A HEPA filter 110 is positioned in the recirculation flow path 106 downstream from the collector 102. Another mounting slot 116 is located in the recirculation flow path 106 upstream from the HEPA filter 110. One of the collectors 102 is positioned within the mounting slot 116. The collector 102 is positioned across the recirculation flow path 106 upstream from the HEPA filter 110 such that the cabin air impinges on the filter material 112 before it is filtered by the HEPA filter 110, thereby allowing the filter material 112 to collect a cabin air particulate sample throughout a duration of a flight. The collector 102 is configured and adapted to be removed from the mounting slot 116 for testing. After the cabin air goes through collector 102, the HEPA filter 110 is configured an adapted to clean air flowing through the recirculation flow path 106 before it goes back into the cabin 10.

[0020] As shown in FIG. 1, both the recirculation flow path 106 and outlet flow path 104, the particulate sample collected within collectors 102 includes droplets exhaled by passengers during the duration of a flight. At the end of a duration of a flight, or any other suitable time, the collector 102 is removed from the mounting slot 116 for testing. Those skilled in the art will readily appreciate that system 100 can operate with only one of the two collectors 102, e.g. only one in the outlet flow path 104 or one in the recirculation flow path 106, or both collectors 102 can be used. The system 100 for monitoring cabin air includes an aircraft galley 15, a pathogen identifying testing unit 25 within the galley, and collectors 102 or 202 (described below). In some embodiments, the pathogen identifying testing unit 25 can be a Polymerase Chain Reaction (PCR) testing unit. Those skilled in the art will readily appreciate that a variety of testing types and/or units may be used as appropriate to test the sample that is collected, such as, radio frequency harmonics, mass spectrum analysis, petri dish smears, etc. The system 100 includes a communication unit 18 for communicating results remotely, as shown schematically by the double-headed arrow between communication unit 18 and a central data center 30. The communication unit 18 is configured to communicate the results to central data center 30, for example, at or in communication with a destination airport.

[0021] As shown in FIGS. 2A-2B, a system 200 for monitoring air includes a collector 202 for collecting particulate samples. The collector 202 is positioned in a positive pressure mask 20 upstream from an outflow valve 208 of the mask 20. The collector 202 is positioned in an outlet flow path 204 and across the outlet flow 204 path upstream from the outflow valve 208. The collector 202 includes a filter material 212 and an adapter 214, e.g., a frame. The filter material 212 is operatively connected to the frame 214. The filter material 212 is mounted to the frame 214. One possible embodiment includes the filter material 212 stretched around frame 214 and slid into a mounting slot 216 over the outflow valve 208 of the mask 20. The mounting slot 216 is located in the outlet flow path 204 upstream from the outflow valve 208 of the mask 20. The filter material 212 acts to capture droplets that are exhaled by the wearer of the mask 20. This

is not being done to protect the wearer of the mask, but rather to allow for testing of the filter afterwards for the presence of virus. It may also protect other people in the vicinity. The filter material **212** within the mask **20** allows for the gathering of a higher concentration of virus than would be possible with a single breath type test. The higher concentration of virus should then be easier to detect in testing.

[0022] With continued reference to FIGS. 2A-2B, the collector **202** is positioned across the outlet flow path **204** upstream from the outflow valve **208** such that air impinges on the filter material **212** thereby allowing the filter material **212** to collect an individual particulate samples throughout a duration of a flight (or another duration) from mask **20**. The collector **202** is configured and adapted to be removed from the mounting slot **216** for testing. Those skilled in the art will readily appreciate that system for monitoring cabin air in aircraft galley **15** (described above) can be used to test the filter material **212** of collector **202**. The testing unit **25** can include a communication unit **18** for communicating results remotely, as shown schematically by the arrow in broken lines. The communication unit **18** is configured to communicate the results to a destination airport. System **200** could extend to other areas, too. Much like radiation exposure monitoring tags worn by medical and nuclear industry workers, the pressure mask type exhale filters may be used for enhanced “quick” testing of other common-carrier or frontline workers (e.g. train staff, first responders, nurses, doctors, etc.) or people working in highly sensitive environments (e.g. nursing homes) Like radiation dosimetry, periodic testing of the filter material **212** could then be used to determine the infectious status of the wearer. At the travel level, this innovation provides a means of quickly clearing the entire aircraft, train, etc. as being “virus free” by checking a filter/screen at the outflow valve for possible contamination.

[0023] With continued reference to FIGS. 2A-2B, collector **202** attaches to cover the exhale/exhaust ports labeled **205** on FIG. 3. The filter material **212** is enclosed in a cartridge type adapter, e.g. the frame **214**, to form the collector. The collector **202** fastens on the inside of the mask **20** over the outflow valves **208** of the positive pressure mask. These collectors **202** can be labeled by flight and seat number, placed in a sealed bag, and deposited at the end of the flight with the gate agent. The filter material **212** is removed from the adapter **214** for testing, and the adapter **214** is cleaned (e.g. dunked in isopropyl alcohol) and a fresh filter material is installed for the next use on the next flight.

[0024] A method for collecting particulates from aircraft air includes capturing particulates in at least one of an outlet flow path, e.g. outlet flow path **104** or **204**, or a recirculation flow path, e.g.

[0025] recirculation flow path **106**, with a collector, e.g. collector **102** or **202**, for a period of time. Those skilled in the art will readily appreciate that the period of time can be a duration of a flight. The method includes removing the collector from at least one of the outlet flow path or the recirculation flow path for testing. The method includes inserting a clean collector, e.g. another collector **102** or **202**, into at least one of the outlet flow path or the recirculation flow path for use during another period of time. The collector can include an adaptor, e.g. frame **114** or **214**, and a filter material, e.g. filter material **112** or **212**, operatively connected to the adaptor. For the collector removed after a

given flight, e.g. used collector, the method can include removing the filter material of the used collector from the adaptor for testing. The method can include cleaning the adapter of the used collector in isopropyl alcohol and then mounting fresh filter material to the adaptor for use for another collection duration.

[0026] The method includes conducting a pathogen identifying test on at least one particulate captured in the filter material of the collector. In some embodiments, the pathogen identifying test can be a Polymerase Chain Reaction (PCR) test. It is contemplated that the pathogen identifying test can be done on-board an aircraft after the duration of the flight to determine if the aircraft is virus free upon arrival and/or before or after the filter material is removed from the frame. The method can include relaying a result of the pathogen identifying test to a central data center, e.g. central data center **30**.

[0027] The methods and systems of the present disclosure, as described above and shown in the drawings, provide for systems for monitoring aircraft air with superior properties including allowing for the detection of a virus or other contaminant. The systems and methods of the present invention can apply to aircraft travel, or the like. While the apparatus and methods of the subject disclosure have been shown and described with reference to preferred embodiments, those skilled in the art will readily appreciate that changes and/or modifications may be made thereto without departing from the scope of the subject disclosure.

What is claimed is:

1. A system for monitoring cabin air comprising:
 - a collector for collecting particulate samples positioned within at least one of an outlet flow path or a recirculation flow path; and
 - at least one of an outflow valve positioned in the outlet flow path downstream from the collector or a HEPA filter positioned in the recirculation flow path downstream from the collector.
2. The system of claim 1, wherein the collector includes a filter material.
3. The system of claim 1, wherein the HEPA filter is configured and adapted to clean air flowing through the recirculation flow path.
4. The system of claim 1, wherein the particulate samples include droplets exhaled from passengers throughout a duration of a flight.
5. The system of claim 1, wherein the collector includes an adaptor and a filter material operatively connected to the adaptor.
6. The system of claim 5, wherein the adaptor is a frame and the filter material is mounted to the frame.
7. The system of claim 1, further comprising a mounting slot in the outlet flow path upstream from the outflow valve, wherein the collector is positioned within the mounting slot.
8. The system as recited in claim 1, wherein the collector is configured and adapted to be removed from the mounting slot for testing.
9. The system of claim 1, wherein the outflow valve is positioned in a positive pressure mask, wherein the collector is positioned across the outlet flow path upstream from the outflow valve to collect individual particulate samples throughout a duration of a flight.
10. The system of claim 1, wherein the outlet flow path is a general cabin outlet flow path and wherein the outflow valve is positioned within the general cabin outlet flow path,

wherein the collector is positioned across the general cabin outlet flow path upstream from the outflow valve to collect a cabin air particulate sample throughout a duration of a flight.

11. A method for collecting particulates from cabin air comprising:

capturing particulates in at least one of an outlet flow path or a recirculation flow path with a collector for a period of time;

removing the collector from at least one of the outlet flow path or the recirculation flow path for testing; and

inserting a clean collector into at least one of the outlet flow path or the recirculation flow path for use during another period of time.

12. The method of claim **11**, further comprising conducting a pathogen identifying test on at least one particulate captured in the collector.

13. The method of claim **12**, further comprising relaying a result of the pathogen identifying test to a central data center.

14. The method of claim **12**, wherein the period of time is a duration of a flight, and wherein the pathogen identify-

ing test is done on-board an aircraft after the duration of the flight to determine if the aircraft is virus free upon arrival.

15. The method of claim **11**, wherein the collector includes an adaptor and a filter material operatively connected to the adaptor, the method further comprising removing the filter material from the adaptor.

16. The method of claim **15**, further comprising cleaning the adapter in isopropyl alcohol.

17. A system for monitoring aircraft air comprising:

an aircraft galley;

a pathogen identifying testing unit within the aircraft galley; and

a collector fluidly connected to at least one of an outflow valve of a positive pressure mask, or an outflow valve of the aircraft.

18. The system of claim **17**, wherein the pathogen identifying testing unit includes a communication unit for communicating results remotely.

19. The system of claim **18**, wherein the communication unit is configured to communicate the results to a destination airport.

* * * * *