

D. A. ROBINSON.
 MEANS FOR TRANSMITTING POWER TO GRAIN ELEVATORS.
 No. 484,048. Patented Oct. 11, 1892.

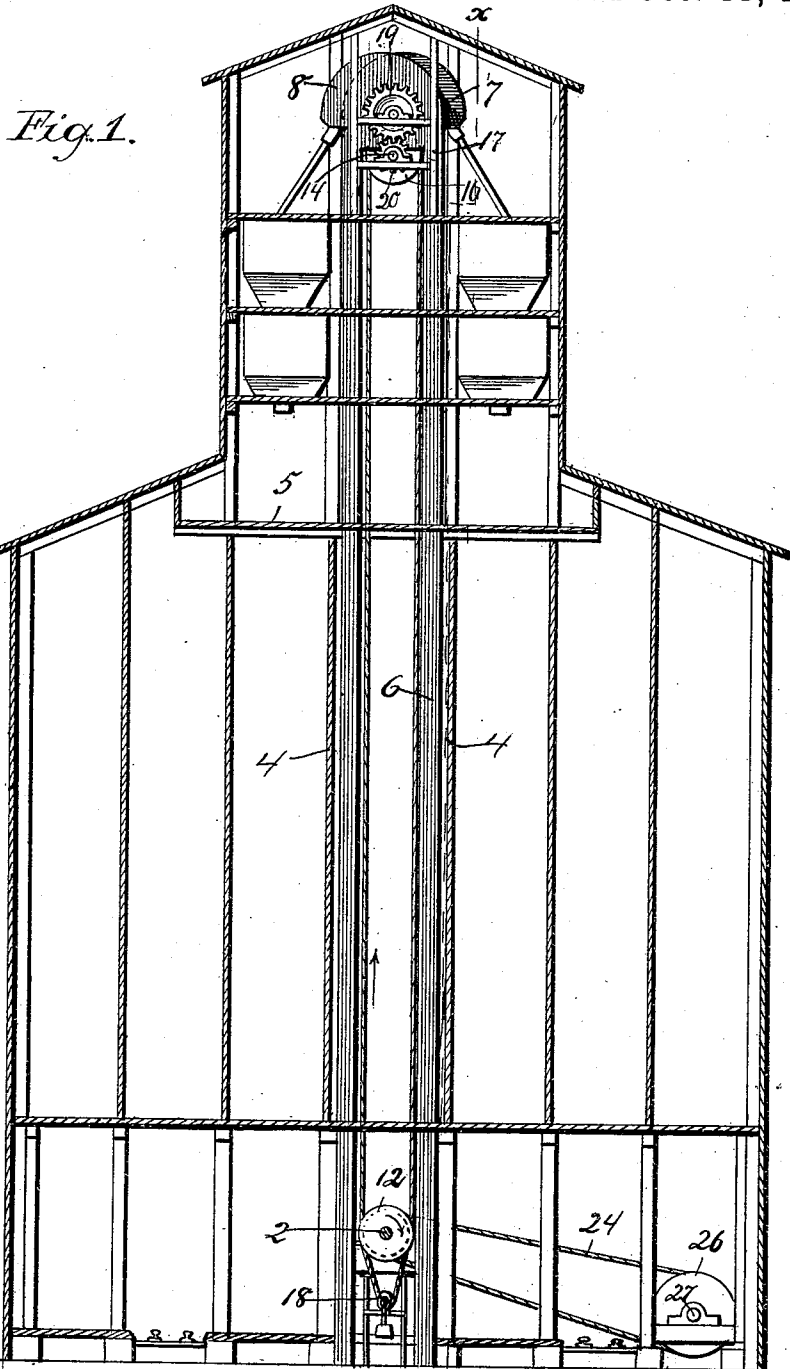

Fig. 1.

Witnesses:
J. J. J.
O. Hawley,

Inventor
Dighton A. Robinson
By Paul Merriman atty. at l.

D. A. ROBINSON.

MEANS FOR TRANSMITTING POWER TO GRAIN ELEVATORS.

No. 484,048.

Patented Oct. 11, 1892.

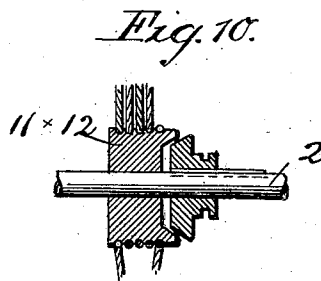
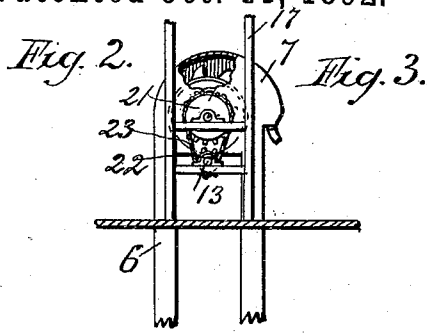
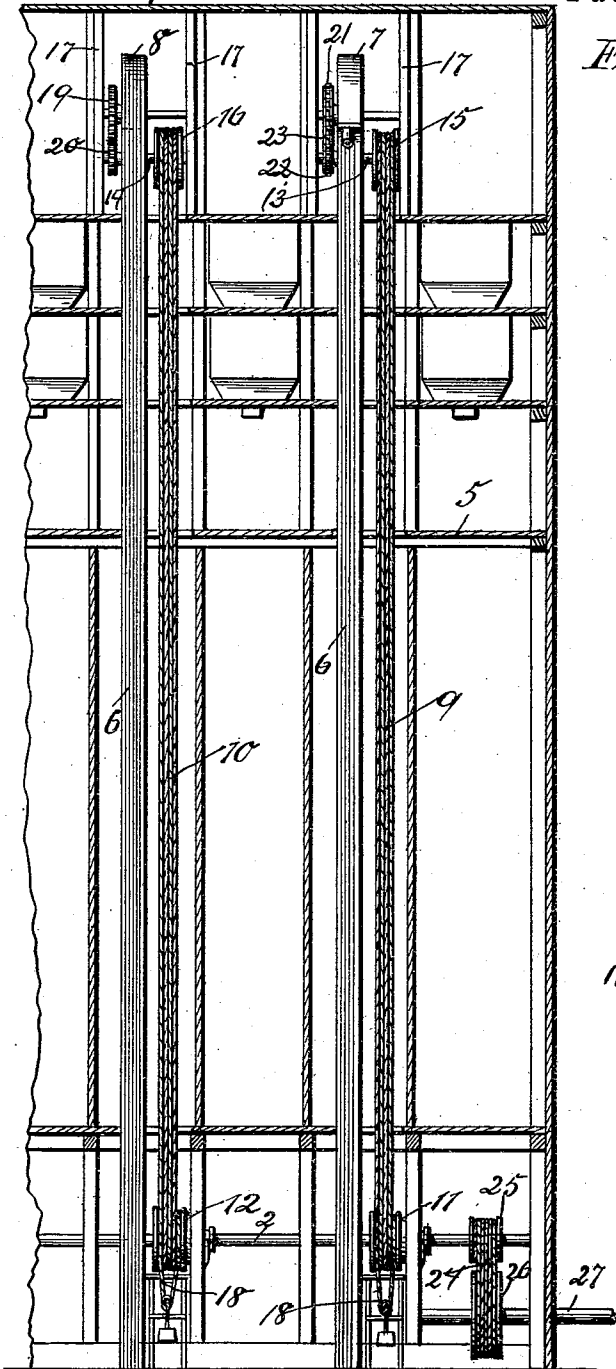

Witnesses:

J. Jensen

O. Hawley

Inventor

Dighton A. Robinson

By Paul Marvin Atty.

D. A. ROBINSON.

MEANS FOR TRANSMITTING POWER TO GRAIN ELEVATORS.

No. 484,048.

Patented Oct. 11, 1892.

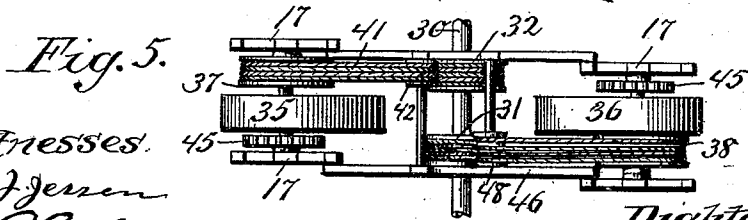
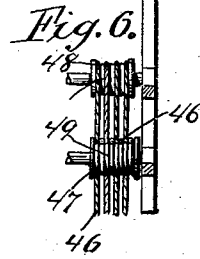
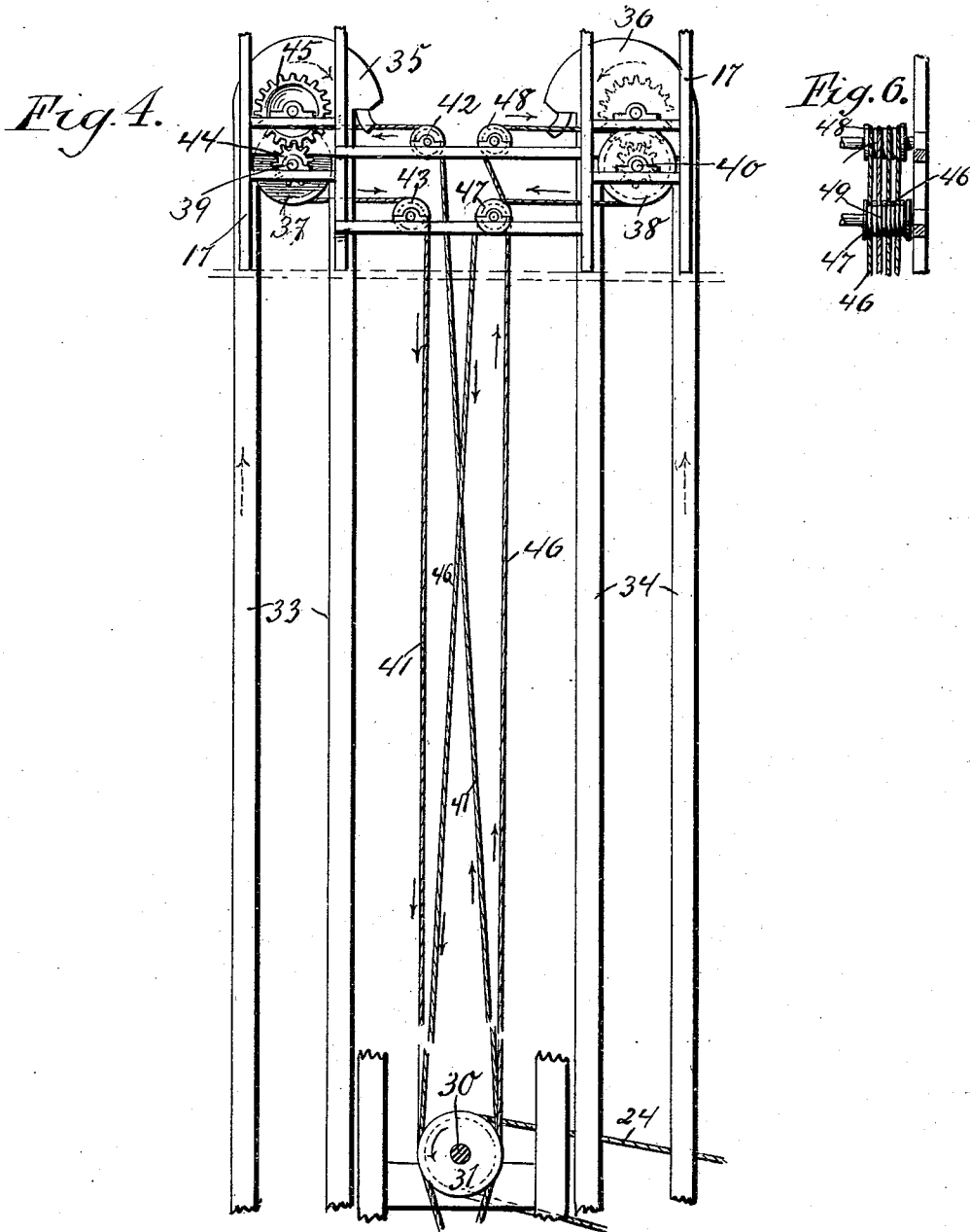

Witnesses.

J. Jensen
O. Hawley

Inventor.

Dighton A. Robinson

By Paul & Merwin attys.

D. A. ROBINSON.

MEANS FOR TRANSMITTING POWER TO GRAIN ELEVATORS.

No. 484,048.

Patented Oct. 11, 1892.

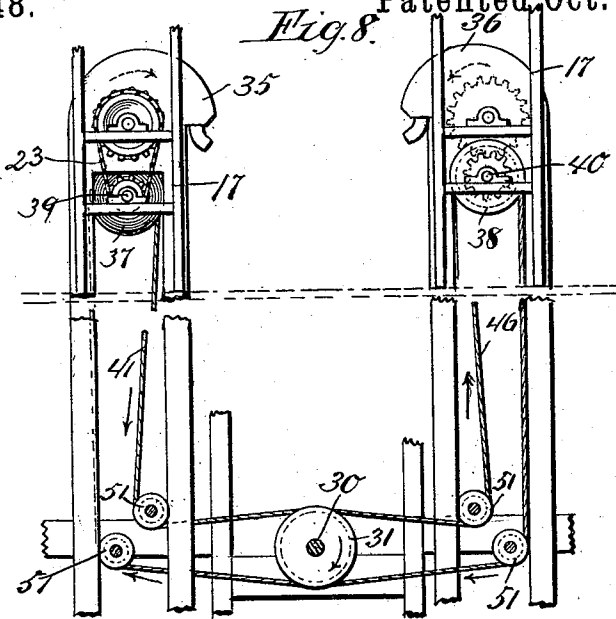

Fig. 8.

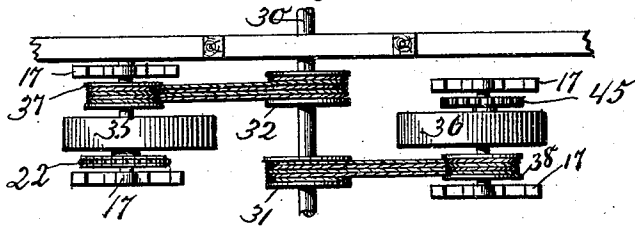

Fig. 9.

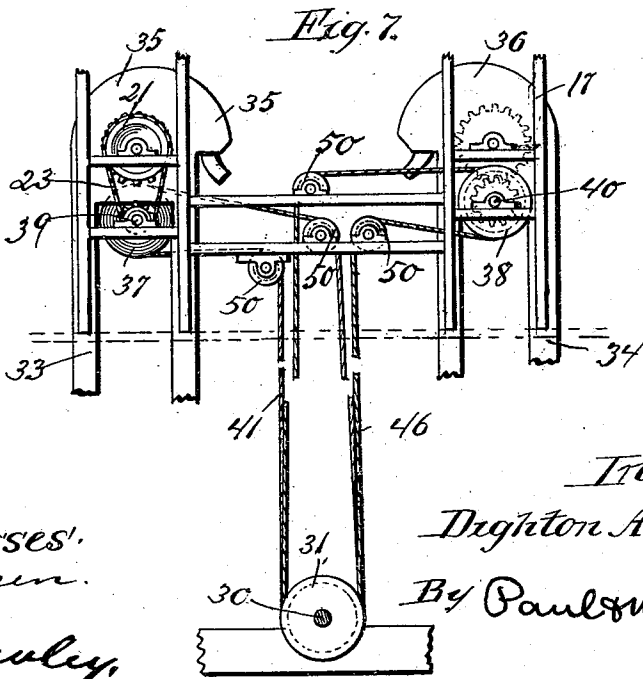

Fig. 7.

Witnesses:
 J. J. Jernin.
 O. Hawley.

Inventor:
 Dighton A. Robinson
 By Paul & Merwin
 attys

UNITED STATES PATENT OFFICE.

DIGHTON A. ROBINSON, OF MINNEAPOLIS, MINNESOTA.

MEANS FOR TRANSMITTING POWER TO GRAIN-ELEVATORS.

SPECIFICATION forming part of Letters Patent No. 484,048, dated October 11, 1892.

Application filed June 26, 1891. Serial No. 397,626. (No model.)

To all whom it may concern:

Be it known that I, DIGHTON A. ROBINSON, of Minneapolis, in the county of Hennepin and State of Minnesota, have invented certain
5 Improvements in Means for Transmitting Power to Grain-Elevators, (Case No. 3,) of which the following is a specification.

My invention relates to means whereby I am enabled to obtain a head-drive for the elevator-belts and at the same time retain the
10 main longitudinal drive in the lower story of the building, where it may be readily attended to and kept in order and where it will not be subject to contortion or strain by reason of
15 movements of the upper part of the elevator-building.

The object of this invention is to cheapen and simplify the construction and operation of elevators, to render the use of machinery
20 in the building safe and reliable, and to render rope-drives efficient and durable.

With these objects in view my invention consists generally in the arrangement of a main longitudinal shaft in the lower part of
25 the building and centrally located therein, in combination with one or more drive-belts proceeding therefrom and adapted to operate an equal number of grain-elevator belts.

Further, my invention consists in a particular arrangement for driving from such a central shaft pairs of elevator-belts located in different sides of the building, and my invention relates especially to improvements upon the mechanism shown and described in my
30 patent upon power transmission for grain-elevators, granted October 6, 1891, and numbered 460,661; and my invention consists, further, in various constructions and combinations hereinafter described, and particularly pointed
40 out in the claims.

My invention will be more readily understood by reference to the accompanying drawings, in which—

Figure 1 is a transverse sectional elevation of an elevator-building provided with apparatus embodying my invention. Fig. 2 is a partial longitudinal section thereof on the line X X of Fig. 1. Fig. 3 is a detail showing a chain-and-sprocket intermediate gear. Fig.
50 4 shows means for driving a "pair" of elevator-belts from a single central shaft. Fig. 5 is a plan view of the top thereof. Fig. 6 is

a detail illustrating the manner of interlacing the rope belts. Fig. 7 shows a modified form of the Fig. 4 drive. Fig. 8 is a further modification of the same. Fig. 9 is a plan view taken from Fig. 8. Fig. 10 is a sectional detail.

As shown in the drawings, the shaft 2 instead of being located in the cupola of the building is arranged in the lower story thereof and may, therefore, be readily and easily kept in good repair and condition. Further, this shaft is located centrally in the building and the rope drive-belts extend from drive-pulleys thereon up through the central bins 4 of the building, and thence through the distributing-floor 5 into the cupola, which contains the weighing-bins, &c.

The elevator-belts are of the ordinary construction and run over head and boot pulleys arranged at the upper and lower ends of the elevator-casings 6.

In Figs. 1 and 2 I have shown what may be termed a pair of "longitudinally-arranged elevator belts and casings," the casings of each being arranged to straddle or embrace the line-shaft 2. In order to admit of the convenient distribution of the grain carried into the top of the elevator-building to the different parts of the same, I arrange the elevator-belts to rotate in opposite directions, whereby, as indicated by the elevator-heads 7 and 8, the grain is discharged into opposite sides of the building. Separate rope-drives 9 and 10
85 are provided for the two elevator-belts and pass over drive-pulleys 11 and 12, respectively, secured on the shaft 2 by suitable clutch devices, whereby the operation of each drive-belt is rendered independent of all others. 90 Just beneath the heads 7 and 8 I arrange the short counter-shafts 13 and 14, bearing the upper drive-pulleys 15 and 16, respectively, and secured in suitable bearings provided in the frames 17. Suitable tension devices 18 are
95 provided in connection with each rope-drive for adjusting the slack thereof. It is obvious that as both pulleys 11 and 12 are secured upon the same shaft that the drive-belts will operate in the same directions. Consequently, 100 as it is desired to operate the elevator-belts in opposite directions, it is necessary to provide means for reversing the action of one drive-belt upon its elevator-belt with respect

to the action of the other. This I accomplish, as shown in Figs. 1, 2, and 3, by the use of one elevator-head of a gear and pinion 19 20, and at the other a direct drive constituted by the sprockets 21 and 22 and the link belt chain 23, the relative sizes of the gears and the sprockets being preferably the same, in order that the elevator-belts may be driven at corresponding speeds. It will be seen that the shaft 2, being driven by the belt 24, extending over the drive-pulley 25 from the large wheel 26 on the engine-shaft 27, that the belt will be operated in the direction of the vertical arrows in Fig. 1. The pulley and elevator-belt in the head 7 will obviously rotate in the same direction, owing to the sprocket intermediate drive, while it is obvious that the other elevator-belt will be operated in an opposite direction, owing to its connection with the drive-belt by the pinion and gear adapted to reverse its movement with respect to its drive-belt.

For use in elevator-buildings of greater size and capacity than that indicated in Figs. 1 and 2, I prefer to employ that embodiment of my invention shown in Figs. 4 to 9, showing means for driving from a central shaft elevator-belts arranged on opposite sides thereof. In these figures the central shaft 30 corresponds to the shaft 2 of the preceding figures and the drive-pulleys 31 and 32 to the pulleys 11 and 12 of said figures. The elevator-casings 33 and 34 contain elevator-belts arranged to rotate in opposite directions, so as to discharge the grain toward the center of the building through the heads 35 and 36. The drive-belts may either pass up through the middle of the building or be separated, as in Fig. 8, and extend up at the side of the elevator-casings. It is obvious that in case the action of one drive-belt upon its elevator-belt must be opposite to that of the other drive-belt on the other elevator-belt, and consequently instead of running the rope drive-belts directly up and over drive-pulleys 37 and 38, arranged on counter-shafts 39 and 40, extending beneath the heads 35 and 36, I provide means for reversing the action of one of the belts with respect to the other. As shown in Figs. 4, 5, and 6, I accomplish this reversal by crossing and by interlacing the drive-belts. The rope drive-belt 41 is arranged to operate the elevator-belt in the casing 33 and from its drive-pulley 32, passing up over the grooved idler 42, and thence extends horizontally over and around the drive-pulley 37, from thence passing back and down over the idler 43. It will be seen that this belt, operating in the direction of the arrows in Fig. 4, will drive the pinion 44 so as to revolve the large gear 45 and the head-pulley secured on the same shaft therewith in the proper direction to discharge the grain toward the center of the building. The other drive-belt 46 is arranged on the opposite side of the casing from the belt 41 and passes from its drive-pulley 31 up over the wide grooved

pulley 47 and from thence over the upper idler 48. From the idler 48 the belt is looped about the drive-pulley 38 and thence proceeds down over the idler 47 to the lower drive-pulley. In order to successfully cross the up and down going sides of the belt 46, I provide the idlers 47 and 48 with a double number of grooves 49, as shown in Fig. 6. The distances between the centers of the grooves being somewhat greater than the diameter of the ropes employed, the strands of the belt are separated, as shown, and those of the different sides thereof interlaced. It will be observed that the two sides of the belt 46 pass up on opposite sides of the idler 47, thereby tending to rotate it in the same direction. The reduction of the speed between the drive-belt and the elevator-belt passing through the head 36 is secured by the use of a pinion and gear similar to that before described.

Where it is desired to avoid the crossing and interlacing of one of the belts, as in the case of the belt 46, I accomplish the reversal by the employment of a direct-drive sprocket device at one head and a gear-and-pinion drive at the other, as shown in Fig. 7, the belts therein shown being simply extended over idlers 50 in the top of the building or part way up therein, in order that the upper loop of the drive-belt may be carried across to the different sides of the building. In some cases it is preferable to arrange these idlers in the lower story of the building and substantially on a level with the main drive-shaft and pulleys, the idlers 51 therein corresponding to the idlers 50 of Fig. 7 and the same head-drives used as therein shown. In this case the drive-belts are extended up upon each side of the building and in close proximity to their elevator belts and casings. It will thus be seen that I attain the principal object of my invention—namely, head-drives for the elevator-belts—from a shaft located in a central and convenient position in the lower story of the building, and, further, by the use of the friction-clutches mentioned as employed in connection with the main drive-pulleys I acquire the absolute and independent control of each and every elevator-belt from the lower floor of the building; further, by the particular arrangements of the rope drive-belts in such a way as to render a constant and close attention to the same convenient and easy and by employing few turns and angles therein I make the same durable and thoroughly efficient, thereby practically overcoming the old objections to rope-drives as compared with leather or other solid belts.

Having thus described my invention, I claim as new and desire to secure by Letters Patent—

1. The combination, with a shaft located centrally in the lower part of the building, of an elevator belt or belts extending into the top thereof, boot-pulleys for said belts, arranged in the lower part of the building, a head or head-pulleys for said belts, drive-pul-

leys secured on said central shaft, said boot and drive pulleys being secured on separate shafts by suitable clutches, and means for driving said head pulley or pulleys from said drive pulley or pulleys on said central shaft, substantially as described.

2. The combination, with a main shaft centrally located in the lower part of the building, of means for driving the same, drive-pulleys thereon, two or more elevator-belts, head and boot pulleys therefor, idlers, drive-belts extending from said drive-pulleys over the same to drive said head-pulleys, and means for reversing the action of said belts upon said head-pulleys with respect to one another, substantially as described.

3. The combination, with a main shaft centrally located in the lower part of the building, of drive-pulleys and means for frictionally securing the same thereon, head-pulleys therefor, and rope-drive belts passing from said drive-pulleys on the main shaft over idlers and to power connections with said head-pulleys, one of said connections being for a direct drive and the other adapted to reverse the movement, substantially as described.

4. The combination, with a main central shaft located in the lower part of the building, of an elevator-belt arranged on each side thereof, head-pulleys and driving-gears therefor secured on short counter-shafts, idlers arranged in the upper part of the building, and belts passing up through the central part of the

building thereto and from thence over drive-pulleys arranged in connection with said head-pulleys, substantially as described.

5. The combination, with the centrally-located shaft provided in the lower story of the building, of an elevator-belt arranged on each side thereof, drive-pulleys adapted to be secured on said shaft by suitable clutches, head-pulleys for said elevator-belts, shafts arranged beneath the same, drive-pulleys arranged thereon, idlers arranged on a substantial level therewith, and rope-drive belts passing through the center of the building and over said idlers and to said drive-pulleys, said belts being crossed and interlaced to secure a reverse action of one of the same upon its elevator-belt with respect to the other elevator-belt, substantially as described.

6. The combination, with a main drive-shaft and the elevator-belts, of head and boot pulleys therefor, with the rope-drive belts passing from said drive-shaft and each made up of two or more strands, and the idlers over which said belts run, two of said idlers being double grooved and the strands of one belt of each pair being interlaced thereon, as and for the purpose specified.

In testimony whereof I have hereunto set my hand this 16th day of June, 1891.

DIGHTON A. ROBINSON.

In presence of—

PAUL GORES,
FRED SCHAEFFER.