



- (51) **International Patent Classification:**  
*H01R 13/11* (2006.01) *H05K 1/18* (2006.01)  
*H01R 33/76* (2006.01)
- (21) **International Application Number:** PCT/IB2013/050082
- (22) **International Filing Date:** 4 January 2013 (04.01.2013)
- (25) **Filing Language:** English
- (26) **Publication Language:** English
- (30) **Priority Data:**  
13/351,731 17 January 2012 (17.01.2012) US
- (71) **Applicant:** INTERNATIONAL BUSINESS MACHINES CORPORATION [US/US]; New Orchard Road, Armonk, New York 10504 (US).
- (71) **Applicants (for MG only):** IBM UNITED KINGDOM LIMITED [GB/GB]; PO Box 41, North Harbour, Portsmouth Hampshire PO6 3AU (GB). IBM (CHINA) INVESTMENT COMPANY LIMITED [CN/CN]; 25/F, Pangu Plaza, No.27, Central North 4th Ring Road, Chaoyang District, Beijing 100101 (CN).
- (72) **Inventors:** SINGH, Prabjit; IBM Corporation, 2455 South Road, Poughkeepsie, New York 12601-5400 (US). LOPERGOLO, Emanuele, Frank; IBM Corporation, 2455 South Road, Poughkeepsie, New York 12601-5400 (US). FLORENCE JR, Robert; IBM Corporation, 2455 South Road, Poughkeepsie, New York 12601-5400 (US).
- (74) **Agent:** LITHERLAND, David; IBM United Kingdom Limited, Intellectual Property Law, Hursley Park, Winchester Hampshire SO21 2JN (GB).
- (81) **Designated States (unless otherwise indicated, for every kind of national protection available):** AE, AG, AL, AM, AO, AT, AU, AZ, BA, BB, BG, BH, BN, BR, BW, BY, BZ, CA, CH, CL, CN, CO, CR, CU, CZ, DE, DK, DM, DO, DZ, EC, EE, EG, ES, FI, GB, GD, GE, GH, GM, GT, HN, HR, HU, ID, IL, IN, IS, JP, KE, KG, KM, KN, KP, KR, KZ, LA, LC, LK, LR, LS, LT, LU, LY, MA, MD, ME, MG, MK, MN, MW, MX, MY, MZ, NA, NG, NI, NO, NZ, OM, PA, PE, PG, PH, PL, PT, QA, RO, RS, RU, RW, SC, SD, SE, SG, SK, SL, SM, ST, SV, SY, TH, TJ, TM, TN, TR, TT, TZ, UA, UG, US, UZ, VC, VN, ZA, ZM, ZW.
- (84) **Designated States (unless otherwise indicated, for every kind of regional protection available):** ARIPO (BW, GH, GM, KE, LR, LS, MW, MZ, NA, RW, SD, SL, SZ, TZ, UG, ZM, ZW), Eurasian (AM, AZ, BY, KG, KZ, RU, TJ, TM), European (AL, AT, BE, BG, CH, CY, CZ, DE, DK, EE, ES, FI, FR, GB, GR, HR, HU, IE, IS, IT, LT, LU, LV, MC, MK, MT, NL, NO, PL, PT, RO, RS, SE, SI, SK, SM, TR), OAPI (BF, BJ, CF, CG, CI, CM, GA, GN, GQ, GW, ML, MR, NE, SN, TD, TG).
- Published:**
- with international search report (Art. 21(3))
  - before the expiration of the time limit for amending the claims and to be republished in the event of receipt of amendments (Rule 48.2(h))

(54) **Title:** INTERPOSER WITH COMPRESSIBLE CONDUCTORS

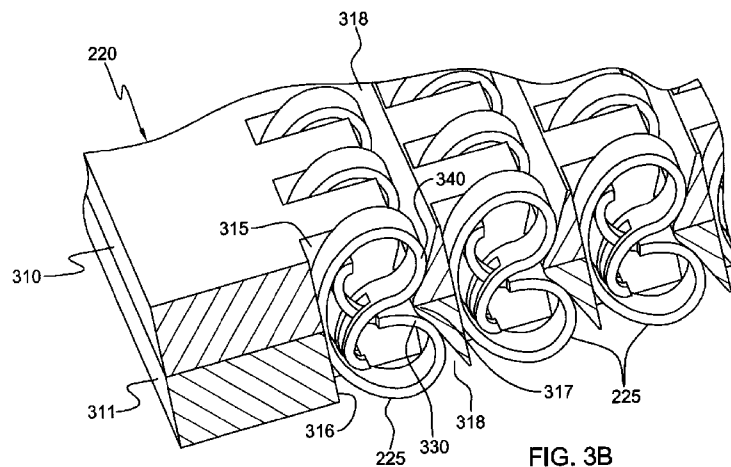

FIG. 3B

(57) **Abstract:** An electrical interconnect is provided for use within, for example, a land grid array (LGA) interposer such as a module-to-board connector. The electrical interconnect includes an electrically-conductive, compressible conductor which has a first conductor end portion and a second conductor end portion. The first and second conductor end portions physically contact in slidable relation each other with compression of the compressible conductor to facilitate inhibiting rotation of the compressible conductor. In one embodiment, the first end portion includes at least one first leg and the second end portion includes at least two second legs, and the at least one first leg and at least two second legs are interdigitated. Further, in one embodiment, the first end portion and the second end portion are each in slidable contact with an inner-facing surface of the compressible conductor.

## INTERPOSER WITH COMPRESSIBLE CONDUCTORS

### FIELD OF THE INVENTION

[0001] The present invention relates to an electrical interconnect structure. More particularly the present invention relates to an electrical interconnect comprising an electrically-conductive compressible conductor.

### BACKGROUND

[0002] Land grid array (LGA) interposers, by way of example, provide an array of interconnections between a printed wiring board (PWB) and a chip module, such as a multichip module (MCM), among other kinds of electrical or electronic devices. LGA interposers allow connections to be made in a way which is reversible and do not require soldering as, for instance, with ball grid arrays or column grid arrays. Ball grid arrays are deemed to be somewhat unreliable on larger areas because the lateral thermal coefficients of expansion-driven stresses that develop can exceed the ball grid array strength. Column grid arrays hold together despite the stresses, but are still soldered solutions, and thus, do not allow for field replaceability, which can be significant since replaceability could potentially save a customer costs in the maintenance and upgrading of high-end computers for which LGAs are typically used.

[0003] Various types of LGA interposer structures have been developed, but generally include, for instance, rigid, semi-rigid, or flexible substrate structures having arrays of electrical contacts formed by, for example, spring structures, metal-elastomer composites, wadded wire, etc. State of the art LGA techniques enable MCM-to-board interconnections with I/O interconnect densities/counts and electrical/mechanical properties that are desirable for high-performance CPU module designs. Moreover, LGA provides electrical and mechanical interconnect techniques that allow MCM chip modules to be readily removable from wiring or circuit boards, which is advantageous for high-end modules such as CPU packages which may require repeated re-work during production or are designed to be field-upgradable

**SUMMARY**

**[0004]** In one aspect, provided herein is an electrical interconnect which includes an electrically-conductive, compressible conductor. The electrically-conductive, compressible conductor includes a first conductor end portion and a second conductor end portion. The first conductor end portion and the second conductor end portion physically contact in slidable relation to each other with compression of the electrically-conductive, compressible conductor to, at least in part, facilitate inhibiting rotation of the electrically-conductive, compressible conductor with compression thereof.

**[0005]** In another aspect, an interposer is provided which includes a plurality of electrically-conductive, compressible conductors disposed within the interposer. At least one electrically-conductive, compressible conductor of the plurality of electrically-conductive, compressible conductors comprises a first conductor end portion and a second conductor end portion, wherein the first conductor end portion and the second conductor end portion physically contact in slidable relation to each other with compression of the at least one electrically-conductive, compressible conductor to, at least in part, facilitate inhibiting rotation of the at least one electrically-conductive, compressible conductor with compression thereof.

**[0006]** In a further aspect, an electrical apparatus is provided which includes an interposer of the previous aspect. It also includes a first package structure comprising a package substrate with one or more electronic devices mounted on a first surface of the package substrate, and a first array of contacts of pitch P1 formed on a second surface of the package substrate opposite the first surface. Also included is a second package structure comprising a wiring board with a second array of contacts of pitch P1 disposed on a first surface thereof. The interposer comprises a land grid array interposer disposed between the first and second package structures to provide electrical interconnections between the first and second arrays of contacts via the plurality of electrically-conductive, compressible conductors.

[0007] In yet a further aspect, a method of fabricating an electrical interconnect is provided, which includes: providing an interposer; providing an electrically-conductive, compressible conductor; and disposing the electrically-conductive, compressible conductor within the interposer, wherein in uncompressed state, the electrically-conductive, compressible conductor extends beyond a first surface and a second surface of the interposer, the first and second surfaces being opposite main surfaces of the interposer. The electrically-conductive, compressible conductor includes a first conductor end portion and a second conductor end portion, wherein the first conductor end portion and the second conductor end portion physically contact in slidable relation to each other with compression of the at least one electrically-conductive, compressible conductor to facilitate inhibiting rotation of the at least one electrically-conductive, compressible conductor with compression thereof.

[0008] Additional features and advantages are realized through the techniques of the present invention. Other embodiments and aspects of the invention are described in detail herein and are considered a part of the claimed invention.

#### **BRIEF DESCRIPTION OF THE SEVERAL VIEWS OF THE DRAWINGS**

[0009] Embodiments of the present invention will now be described, by way of example only, with reference to the accompanying drawings in which:

FIG. 1A depicts a partial cross-sectional elevational view of one embodiment of a conventional prior art interposer structure, shown disposed between and electrically connecting a substrate and a wiring board;

FIG. 1B depicts a partial cross-sectional elevational view of another embodiment of a conventional prior art interposer structure, shown disposed between and electrically connecting a substrate and wiring board;

FIG. 2 is a partially exploded view of an electronic apparatus comprising one embodiment of an electrical interconnect, in accordance with one or more aspects of the present invention;

FIG. 3A is an enlarged depiction of the electrical interconnect of FIG. 2, in accordance with one or more aspects of the present invention;

FIG. 3B is a further enlarged depiction of the electrical interconnect of FIGS. 2 & 3A, taken along line 3B-3B in FIG. 3A, in accordance with one or more aspects of the present invention;

FIG. 3C depicts one electrically-conductive, compressive conductor of the electrical interconnect of FIGS. 2, 3A & 3B, shown in uncompressed state, in accordance with one or more aspects of the present invention;

FIG. 4A is a top plan view of the assembled electronic apparatus of FIG. 2, utilizing the electrical interconnect of FIGS. 3A-3C, in accordance with one or more aspects of the present invention;

FIG. 4B is a cross-sectional elevational view of the assembled electronic apparatus of FIG. 4A, taken along line 4B-4B thereof, in accordance with one or more aspects of the present invention; and

FIG. 4C is a partial enlargement of the assembled electronic apparatus of FIG. 4B, taken within line 4C thereof, and illustrating the electrically-conductive, compressible conductors in compressed (or loaded) state, making electrical connection between the module substrate and the wiring board, in accordance with one or more aspects of the present invention.

## **DETAILED DESCRIPTION**

[0010] Reference is made below to the drawings (which are not drawn to scale to facilitate understanding of the invention), wherein the same reference numbers used throughout different figures designate the same or similar components.

[0011] One widely commercially available LGA uses button contacts, each comprising siloxane rubber filled with silver particles. This structure is intended to provide a contact which possesses a rubber-like elasticity with the provision of electrical conductivity. While siloxane itself has very desirable properties for this type of application, incorporating both a low-elastic modulus and high elasticity, the particle-filled siloxane rubber system loses a significant proportion of these desirable properties under the loadings which are required for

electrical conductivity. Although the modulus increases, it remains low overall, and requires only about 30 – 80 grams per contact to ensure good electrical reliability; however, the loss of elasticity results in creep deformation under constant load and stress relaxation under constant strain. These tendencies render electrically-conductive elastomer LGAs unreliable for high-end products which require an extraordinary stability over a lengthy period of time. Indeed, modern high-end server CPUs demand LGA failure rates at ppb levels on a per contract basis because of a total system dependence on individual signal contacts.

**[0012]** Because of the adverse extent of creep and stress relaxation (which has been demonstrated by the filled electrically-conductive elastomer LGAs), the industry favors the use of LGA arrays which are fabricated from random coil springs, such as for instance, a product called the Cinch Connector, which is made by the Synapse Company, of Seattle, Washington, USA. These springs have a much higher spring constant than the electrically-conductive, elastomer-type connector, but typically require greater pressure per contact in order to ensure reliable electrical connection across the array.

**[0013]** There is a strong technical motivating factor for using LGAs instead of rigid, direct-solder attachments between module and printed wiring board (PWB). The lateral stresses that occur due to thermal coefficient of expansion (TCE) mismatches between ceramic modules and organic PWBs are large, and direct, ball-grid-array-type connections often tend to fail. Systems are accordingly advantageous which have some built-in lateral compliance. As noted, one direct-attach solution to address this problem is a so-called “column grid array”, or CGA. The CGA is a permanent, solder-type interconnection that deforms without failing in order to accommodate the lateral stresses imposed.

**[0014]** There is also a strong economic motivating factor for using LGA interposers over direct-attach solutions. This is because repairs and upgrades to chip sets cannot be carried out in the field with direct-attach solutions. Pressure-mounted LGAs can be replaced in the field, thereby saving the customer significant costs in disassembly, shipping and rework down-time.

[0015] Thus, there are both technological and economic advantages to a pressure-type LGA interposer approach. FIGS. 1A & 1B depict two current prior art configurations of a pressure-applied type LGA interposer.

[0016] In FIG. 1A, one embodiment of a conventional prior art, spring-type interposer structure is shown disposed between and electrically connecting a substrate 100, and a wiring board 110. By way of example, substrate 100 may comprise a module substrate having one or more integrated circuit chips (not shown) mounted to a first surface (not shown) of the substrate and a first array of contacts 101 formed on a second surface 102 of the substrate opposite to the first surface. Wiring board 110 may comprise a circuit board having a second array of contacts 111 formed on a first surface 112 thereof. As one example, the first array of contacts 101 and second array of contacts 111 may each be of pitch P1. Also shown in the electronic assembly of FIG. 1A is an interposer structure 120 comprising a plurality of spring-type connectors 125. In the embodiment illustrated, spring-type connectors 125 are C-shaped conductors which are designed to electrically interconnect (when under load) opposing contacts 101, 111 of the substrate and wiring board, respectively. Should the first array of contacts 101 and second array of contacts 111 be slightly misaligned as illustrated in FIG. 1A, then it is possible for a short circuit to arise due the proximity of one or more of the connectors 125 to one or more adjacent contacts of, for example, the first array of contacts or the second array of contacts. In FIG. 1A, the first and second arrays of contacts are misaligned such that the middle illustrated spring-type connector 125 has a bend which is in close proximity 115 with an adjacent contact of the second array of contacts 111 disposed on wiring board 110, and could result in shorting together of the two adjacent contacts 111 via the middle connector 125. Although not illustrated, a similar misalignment could also or alternatively result in shorting together one more adjacent contacts 101 disposed on module substrate 100.

[0017] FIG. 1B illustrates an alternate embodiment of a conventional prior art interposer structure, again shown disposed between and electrically connecting module substrate 100 and wiring board 110. In this embodiment, the interposer structure 130 includes a plurality of spring-type connectors 135, one of which is illustrated, each disposed within a respective opening 131 in the interposer material 132.

**[0018]** Note that, in the prior art embodiment of FIG. 1A, the spring-type connector approximates a cantilevered spring, and is prone to rotation when compressed. This (in turn can) result in a lowered normal force being applied to the contacts above and below the interposer structure. Additionally, note that the connectors illustrated in FIGS. 1A & 1B may become caught within the interposer material, bend and/or drop through the respective openings in the interposer structure housing the connectors. Also, the prior art configurations illustrated in FIGS. 1A & 1B for the electrical connector each have only one electrical path for the signal to flow between the respective aligned upper and lower contacts, making the connection resistance between any two contacts potentially somewhat high.

**[0019]** Generally stated, disclosed herein is a novel electrical interconnect, such as, for example, a land grid array interposer structure. The electrical interconnect comprises an electrically-conductive, compressible conductor which includes a first conductor end portion and a second conductor end portion that extend, in one example, from a C-shaped portion. The first conductor end portion and the second conductor end portion physically contact in slidable relation to each other with compression of the electrically-conductive, compressible conductor to, at least in part, facilitate inhibiting rotation of the electrically-conductive, compressible conductor with compression thereof. In one embodiment, the first conductor end portion includes at least one first leg and the second conductor end portion includes at least two second legs, and the at least one first leg and the at least two second legs are interdigitated. Further, the first conductor end portion and second conductor end portion each physically contact in slidable relation an inner-facing surface of the electrically-conductive, compressible conductor, such as an inner-facing surface of the C-shaped portion of the electrically-conductive, compressible conductor.

**[0020]** Advantageously, the electrically-conductive, compressible conductor includes multiple current paths therethrough when operatively disposed in a compressed (or loaded) state between two electrically conducting contacts. At least one of these current paths passes through at least one of the first conductor end portion or the second conductor end portion. In one embodiment, both the first conductor end portion and the second conductor end portion form respective parts of separate electrical current paths through the electrically-



conductive, compressible conductor. As one characterization, the electrically conductive-compressible conductor is a partially C-shaped structure, with a figure "8" defined therein via the first and second conductor end portions of the conductor. More particularly, and as explained further below, the electrically-conductive, compressible conductor disclosed herein is advantageously designed to: inhibit rotation of the conductor (or button) with compressing thereof, which avoids loss of contact force; provide good retention of the conductor within the interposer, resulting in low probability of the conductor falling out of the interposer; provide three redundant paths for current to flow, thus reducing the contact resistance; and provide a small footprint conductor, leading to low cross-talk between conductors and allowing for a high-performance connection between, for example, the module substrate and the wiring board.

**[0021]** FIG. 2 depicts an electronic apparatus according to an embodiment of the present invention comprising an electrical interconnect disposed between a module substrate 200 and a wiring board 210. In this embodiment, the electrical interconnect is a land grid array interposer structure 220, which includes a plurality of electrically-conductive, compressible conductors 225 arrayed within the interposer structure. Module substrate 200 supports, in the embodiment depicted, one or more integrated circuit chips 205 on a first surface 201 thereof, and a first array of contacts (not shown) of pitch P1 formed on a second surface 202 of the module substrate, wherein the first surface 201 and second surface 202 are opposite surfaces of the module substrate 200. As illustrated, wiring board 210 includes a second array of contacts 211 of, for example, pitch P1 disposed on a first surface 212 thereof.

**[0022]** The land grid array interposer structure 220, and in particular, the plurality of electrically-conductive, compressible conductors 225 arrayed therein, provide electrical interconnection between the first and second arrays of contacts when the interposer structure is operatively disposed between substrate module 200 and wiring board 210. Compressive loading can be applied to the compressible conductors via any conventional means, such as one or more adjustable securing mechanisms (not shown), that force the module substrate and wiring board together, and thereby compress the plurality of electrically-conductive, compressible conductors 225. This compression (or loading) of the conductors creates a

normal force between the conductors and the respective first and second contacts, to ensure good electrical connection therebetween.

**[0023]** FIGS. 3A & 3B depict in greater detail one embodiment of interposer structure 220 of FIG. 2. Referring collectively to these figures, interposer structure 220 includes, in the depicted embodiment, an upper housing portion 310 and a lower housing portion 311, which comprise two mating halves of the interposer structure. Dividing the interposer structure into two or more mating portions facilitates assembly of the plurality of electrically-conductive, compressible conductors 225 within respective openings 315 of the interposer structure 220.

**[0024]** As illustrated in FIG. 3B, each respective opening 315 comprises an inner side wall 316 with a side wall protrusion 317 extending at least partially between different portions of the respective electrically-conductive, compressible conductor. In one embodiment, the respective portions are the first conductor end portion 330 and second conductor end portion 340 of the compressible conductor. Note that the side wall protrusion 317 is formed, in this embodiment, by two protrusion halves, each formed in one of the upper and lower housing portions of the interposer structure, which when mated, define side wall protrusion 317. The protrusion is sized so as to extend between different portions of the compressible conductor in order to facilitate maintaining the compressible conductor in position within the respective opening, and to inhibit rotation of the compressible conductor, for example, when compressed by a loading offset from ideal. Note also with respect to FIGS. 3A & 3B, that parallel-extending channels 318 are provided in upper housing portion 310 and lower housing portion 311 to, in one embodiment, facilitate accommodating compression of the respective electrically-conductive, compressible conductors 225 when operatively disposed between, for example, the module substrate and the wiring board.

**[0025]** The compressible conductors 225 may be formed of any compressible, electrically-conducting material. For example, the conductors might comprise beryllium copper, which has a high yield strength, and good electrical conductivity. The interposer material (from which the interposer layer is formed) may comprise, for example, a thermo-set plastic, which has a total height less than the height of the compressible conductors, as

illustrated in FIG. 3B. By way of specific example only, the interposer structure might comprise a 100 x 100 array of compressible conductors in an interposer structure having planar dimensions of approximately 10 cm x 10 cm, and the compressible conductors might be, for example, less than 1 mm in height (such as .5 – .75 mm), and .5 mm or less in width. This results in a compact, compressible conductor (or contact button) design that has numerous advantages, as described herein, over conventional spring-type connectors.

**[0026]** In one embodiment, the compressible conductors 225 disclosed herein can be formed via stamping and bending a continuous, elongate conductor, such as a metal conductor having the desired yield strength to provide the needed compressibility that will facilitate the electrical interconnect functionality described herein, such as, for example, for a land grid array interposer structure. One embodiment of the compressible conductor (or contact button) is illustrated, by way of example, in greater detail in FIG. 3C, wherein compressible conductor 225 is shown to include a C-shaped portion 320, a first conductor end portion 330, and a second conductor end portion 340. In this embodiment as shown, the first and second conductor end portions 330, 340 respectively extend from different ends of C-shaped portion 320 in a continuous manner, and are in slidable contact with each other so as to accommodate loading or unloading of the compressible conductor. As illustrated, first conductor end portion 330 includes at least one first leg 332 and second conductor end portion 340 includes at least two second legs 342, which are shown interdigitated, with a single first leg 332 shown extending between two second legs 342. Further, note that the first conductor end portion 330 and second conductor end portion 340, and more particularly, the at least one first leg 332 and at least two second legs 342 thereof, are in slidable, physical contact with an inner-facing surface 321 of the C-shaped portion 320 of the electrically-conductive, compressible conductor 225. This slidable contacting of the first and second end portions with the inner-facing surface of the C-shaped portion facilitates stabilizing the compressible conductor during loading and unloading thereof; and significantly, provides multiple current paths through the compressible conductor, as described further below in relation to the assembled electronic apparatus of FIGS. 4A-4C. Also note the inwardly-curved ends of the at least one first leg 332 and at least two second legs 342. These curved (or smaller radii) ends prevent the legs from digging into inner-facing surface 321 of the C-shaped portion 320.

[0027] As noted, FIG. 4A depicts a top plan view of the assembled electronic apparatus of the embodiment illustrated in FIGS. 2-3C, with interposer structure 220 disposed between module substrate 200 and wiring board 210. In the embodiment illustrated, one or more integrated circuit chips 205 are disposed on module substrate 200. In the cross-sectional elevational view of FIGS. 4B & 4C, the electrically-conductive, compressible conductors 225 are shown under load, making electrical connection between the first and second arrays of contacts 203, 211 disposed in opposing relation on the facing surfaces of the module substrate 200 and wiring board 210. In this regard, note that the compressible conductors 225 slidingly contact or wipe contacts 203, 211 as the conductors compress, which ensure a good electrical connection between the compressible conductors and the contacts.

[0028] Note that advantageously, there are multiple current paths through the compressive conductors when operationally disposed under compression between two electrically-conducting contacts of the first and second arrays of contacts. These current paths include (in the depicted configuration) a first current path 400 through the C-shaped portion of the compressible conductor, a second current 401 path extending, at least partially, through the first conductor end portion 330 of the compressible conductor, and a third current path 402 extending at least partially through the second conductor end portion 340 of the compressible conductor. Note that, in operation, the multiple current paths through the compressible conductor advantageously reduce resistance of the conductor.

[0029] Those skilled in the art will note from the description provided herein, that the compressible conductors (or contact buttons) of the embodiments can be readily, selectively replaced within an interposer structure, that is, if found to be defective. Further, the compressible conductors disclosed are free of any features that would make them prone to being caught within the interposer material, or bent due to handling. Additionally, electrical connection resistance is less, for example, half or less that of other connectors (such as the above-described, prior art spring-type connectors of FIGS. 1A & 1B), since the compressive conductors disclosed herein have multiple electrical paths through the compressible conductor. Further, the compressible conductors of the embodiments of the present invention described herein, in association with the above-described side wall protrusions within the respective openings, eliminate contact rotation due to less than perfect loading of

the respective compressible conductors. Contact rotation is undesirable because it would reduce the normal force between the compressible conductor and the respective contacts, and result in poor conductor retention within the housing. The compressible conductors of the embodiments described herein also advantageously provide a small footprint, which results in less cross-talk between adjacent contacts, and thereby, higher speed performance.

**[0030]** The terminology used herein is for the purpose of describing particular embodiments only and is not intended to be limiting of the invention. As used herein, the singular forms “a”, “an” and “the” are intended to include the plural forms as well, unless the context clearly indicates otherwise. It will be further understood that the terms “comprise” (and any form of comprise, such as “comprises” and “comprising”), “have” (and any form of have, such as “has” and “having”), “include” (and any form of include, such as “includes” and “including”), and “contain” (and any form contain, such as “contains” and “containing”) are open-ended linking verbs. As a result, a method or device that “comprises”, “has”, “includes” or “contains” one or more steps or elements possesses those one or more steps or elements, but is not limited to possessing only those one or more steps or elements. Likewise, a step of a method or an element of a device that “comprises”, “has”, “includes” or “contains” one or more features possesses those one or more features, but is not limited to possessing only those one or more features. Furthermore, a device or structure that is configured in a certain way is configured in at least that way, but may also be configured in ways that are not listed.

**[0031]** The corresponding structures, materials, acts, and equivalents of all means or step plus function elements in the claims below, if any, are intended to include any structure, material, or act for performing the function in combination with other claimed elements as specifically claimed. The description of the present invention has been presented for purposes of illustration and description, but is not intended to be exhaustive or limited to the invention in the form disclosed. Many modifications and variations will be apparent to those of ordinary skill in the art without departing from the scope of the invention.

## CLAIMS

1. An electrical interconnect comprising:  
an electrically-conductive, compressible conductor comprising:  
a first conductor end portion and a second conductor end portion, the first conductor end portion and the second conductor end portion physically contacting in slidable relation to each other with compression of the electrically-conductive, compressible conductor so as to, at least in part, inhibit rotation of the electrically-conductive, compressible conductor with compression thereof.
2. The electrical interconnect of claim 1, wherein the first conductor end portion comprises at least one first leg and the second conductor end portion comprises at least two second legs, and wherein the at least one first leg of the first conductor end portion and the at least two second legs of the second conductor end portion are interdigitated.
3. The electrical interconnect of claim 2, wherein the first conductor end portion and the second conductor end portion each physically contact in slidable relation an inner-facing surface of the electrically-conductive, compressible conductor.
4. The electrical interconnect of any preceding claim, wherein the electrically-conductive, compressible conductor comprises a partially C-shaped structure with a C-shaped portion, and the first conductor end portion and the second conductor end portion extend from different ends of the C-shaped portion.
5. The electrical interconnect of claim 4, wherein the first conductor end portion and the second conductor end portion each physically contact in slidable relation an inner-facing surface of the C-shaped portion of the partially C-shaped structure.
6. The electrical interconnect of any preceding claim, wherein the electrically-conductive, compressible conductor comprises multiple current paths therethrough between two electrically-conducting contacts when the electrically-conductive, compressible conductor is operatively disposed between the two electrically-conducting contacts, at least

one current path of the multiple current paths between the two electrically-conducting contacts passing through at least one of the first conductor end portion or the second conductor end portion.

7. The electrical interconnect of any preceding claim, further comprising a land grid array interposer, and wherein the electrically-conductive, compressible conductor resides within a respective opening in the land grid array interposer.

8. The electrical interconnect of claim 7, wherein the land grid array interposer comprises an inner side wall defining, at least in part, the respective opening, the inner side wall comprising a side wall protrusion, the side wall protrusion extending at least partially between the first conductor end portion and the second conductor end portion of the electrically-conductive, compressible conductor to facilitate maintaining the electrically-conductive, compressible conductor in position within the respective opening.

9. An interposer comprising:

a plurality of electrically-conductive, compressible conductors disposed within the interposer, each comprising:

a first conductor end portion and a second conductor end portion, the first conductor end portion and the second conductor end portion physically contacting in slidable relation to each other with compression of the electrically-conductive, compressible conductor so as to, at least in part, inhibit rotation of the electrically-conductive, compressible conductor with compression thereof.

10. The interposer of claim 9, wherein the first conductor end portion comprises at least one first leg and the second conductor end portion comprises at least two second legs, and wherein the at least one first leg of the first conductor end portion and the at least two second legs of the second conductor end portion are interdigitated.

11. The interposer of claim 10, wherein the first conductor end portion and the second conductor end portion each physically contact in slidable relation an inner-facing surface of the at least one electrically-conductive, compressible conductor.

12. The interposer of any of claims 9 to 11, wherein the at least one electrically-conductive, compressible conductor comprises a partially C-shaped structure with a C-shaped portion, and the first conductor end portion and the second conductor end portion extend from different ends of the C-shaped portion.
13. The interposer of claim 12, wherein the first conductor end portion and the second conductor end portion each physically contact in slidable relation an inner-facing surface of the C-shaped portion of the partially C-shaped structure.
14. The interposer of any of claims 9 to 13 wherein one of the electrically-conductive, compressible conductors comprises multiple current paths therethrough between two electrically-conducting contacts when the electrically-conductive, compressible conductor is operatively disposed between the two electrically-conducting contacts, at least one current path of the multiple current paths between the two electrically-conducting contacts passing through at least one of the first conductor end portion or the second conductor end portion of the electrically-conductive, compressive conductor.
15. The interposer of any of claims 9 to 14, wherein one of the electrically-conductive, compressible conductors resides within an opening in the interposer, the interposer comprising an inner side wall defining, at least in part, the opening, and the inner side wall comprising a side wall protrusion, the side wall protrusion extending at least partially between the first conductor end portion and the second conductor end portion of the electrically-conductive, compressible conductor so as to facilitate maintaining the electrically-conductive, compressible conductor in position within the respective opening.
16. An electronic apparatus comprising:  
an interposer as claimed in any of claims 9 to 15;  
a first package structure comprising a package substrate with one or more electronic devices mounted on a first surface of the package substrate, and a first array of contacts of pitch P1 formed on a second surface of the package substrate opposite the first surface;  
a second package structure comprising a wiring board with a second array of contacts of pitch P1 disposed on a first surface thereof; and



wherein the interposer comprises a land grid array interposer disposed between the first and second package structures to provide electrical interconnections between the first and second arrays of contacts via the plurality of electrically-conductive, compressible conductors.

17. A method of fabricating an electrical interconnect comprising:

providing an interposer;

providing an electrically-conductive, compressible conductor comprising:

a first conductor end portion and a second conductor end portion, the first conductor end portion and the second conductor end portion physically contacting in slidable relation to each other with compression of the electrically-conductive, compressible conductor to, at least in part, facilitate inhibiting rotation of the electrically-conductive, compressible conductor with compression thereof; and

disposing the electrically-conductive, compressible conductor within the interposer, wherein in uncompressed state, the electrically-conductive, compressible conductor extends beyond a first surface and a second surface of the interposer, the first and second surfaces being opposite main surfaces of the interposer.

18. The method of claim 17, wherein the first conductor end portion comprises at least one first leg and the second conductor end portion comprises at least two second legs, and wherein the at least one first leg of the first conductor end portion and the at least two second legs of the second conductor end portion are interdigitated.

19. The method of claim 18, wherein the first conductor end portion and the second conductor end portion each physically contact in slidable relation an inner-facing surface of the electrically-conductive, compressible conductor.

20. The method of any of claims 17 to 19, wherein the electrically-conductive, compressible conductor comprises a partially C-shaped structure with a C-shaped portion, and the first conductor end portion and the second conductor end portion extend from different ends of the C-shaped portion, and wherein the first conductor end portion and the

second conductor end portion each physically contact in slidable relation an inner-facing surface of the C-shaped portion of the partially C-shaped structure.

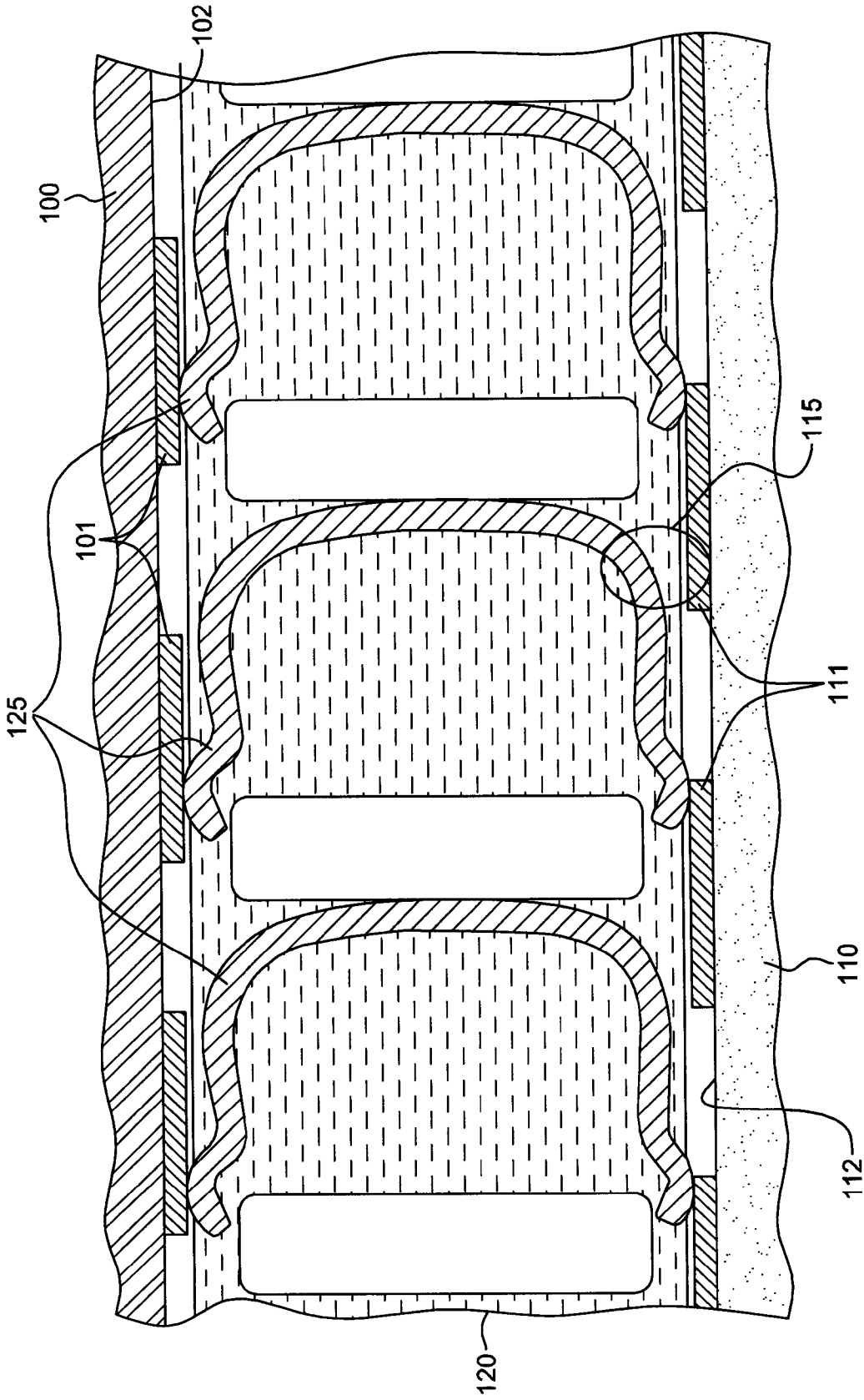
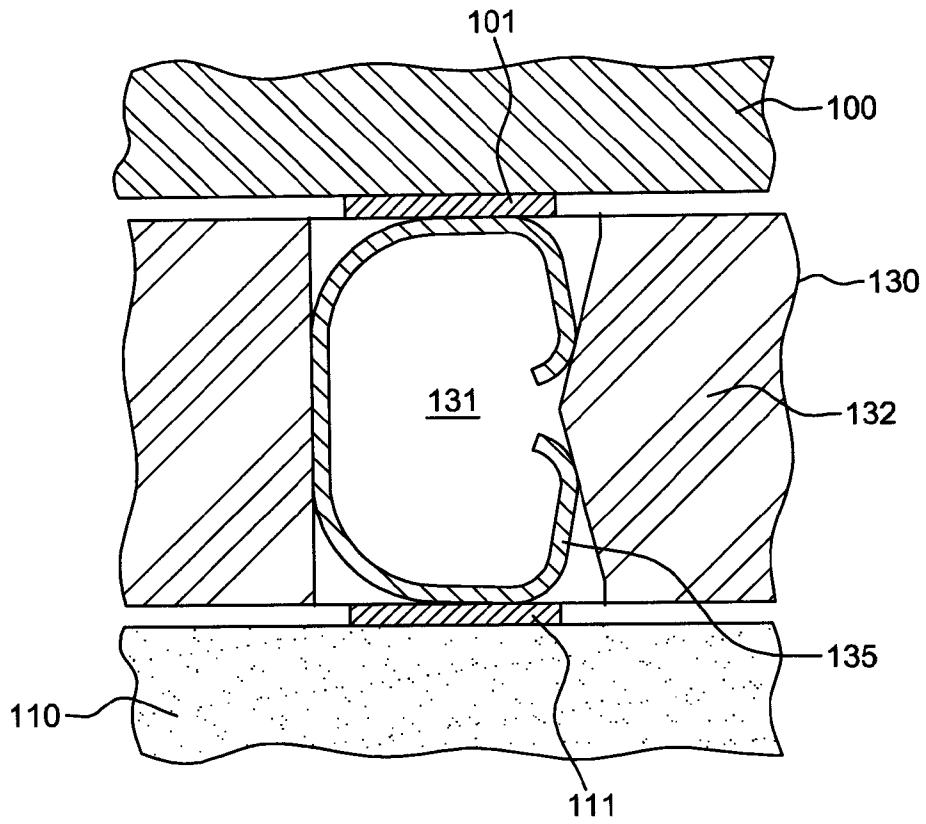

FIG. 1A  
(PRIOR ART)



**FIG. 1B**  
(PRIOR ART)

3/8

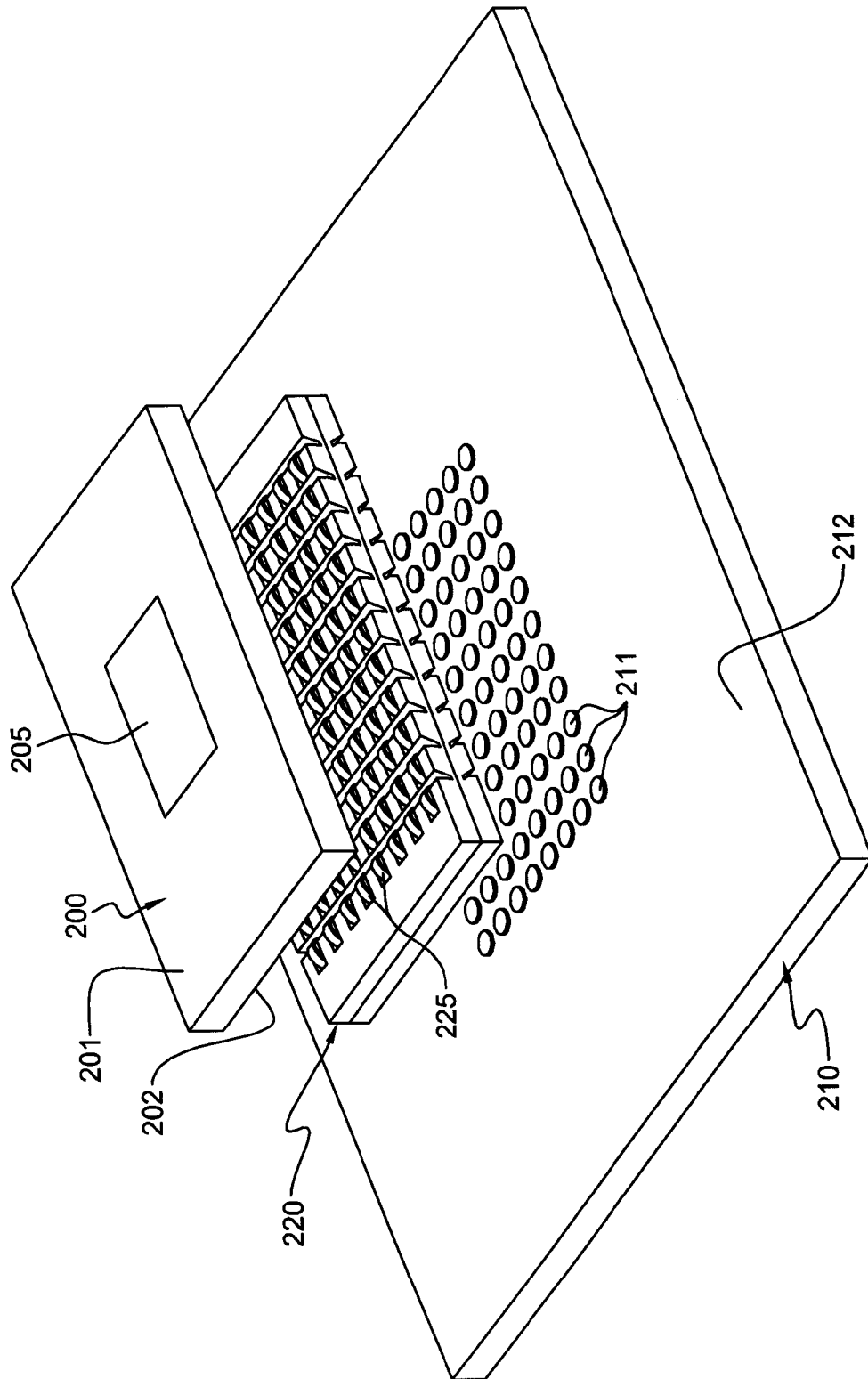
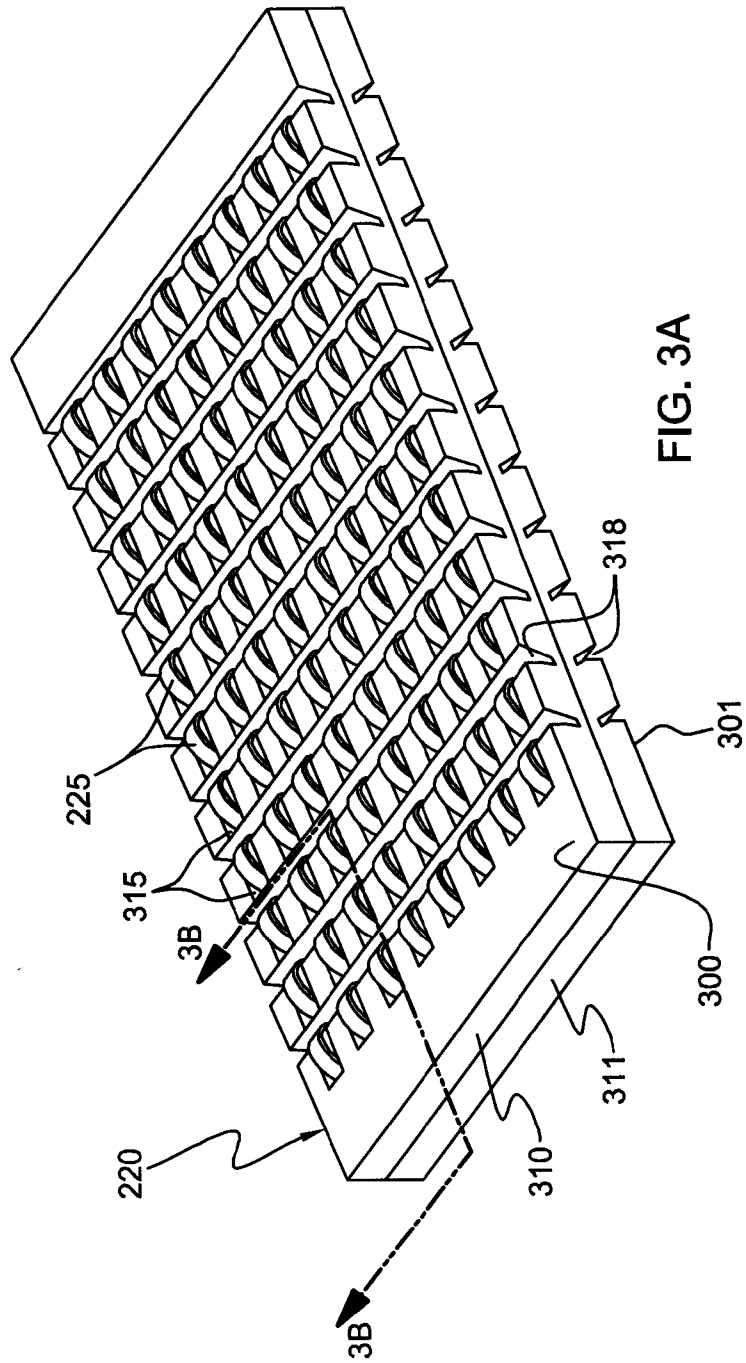

FIG. 2



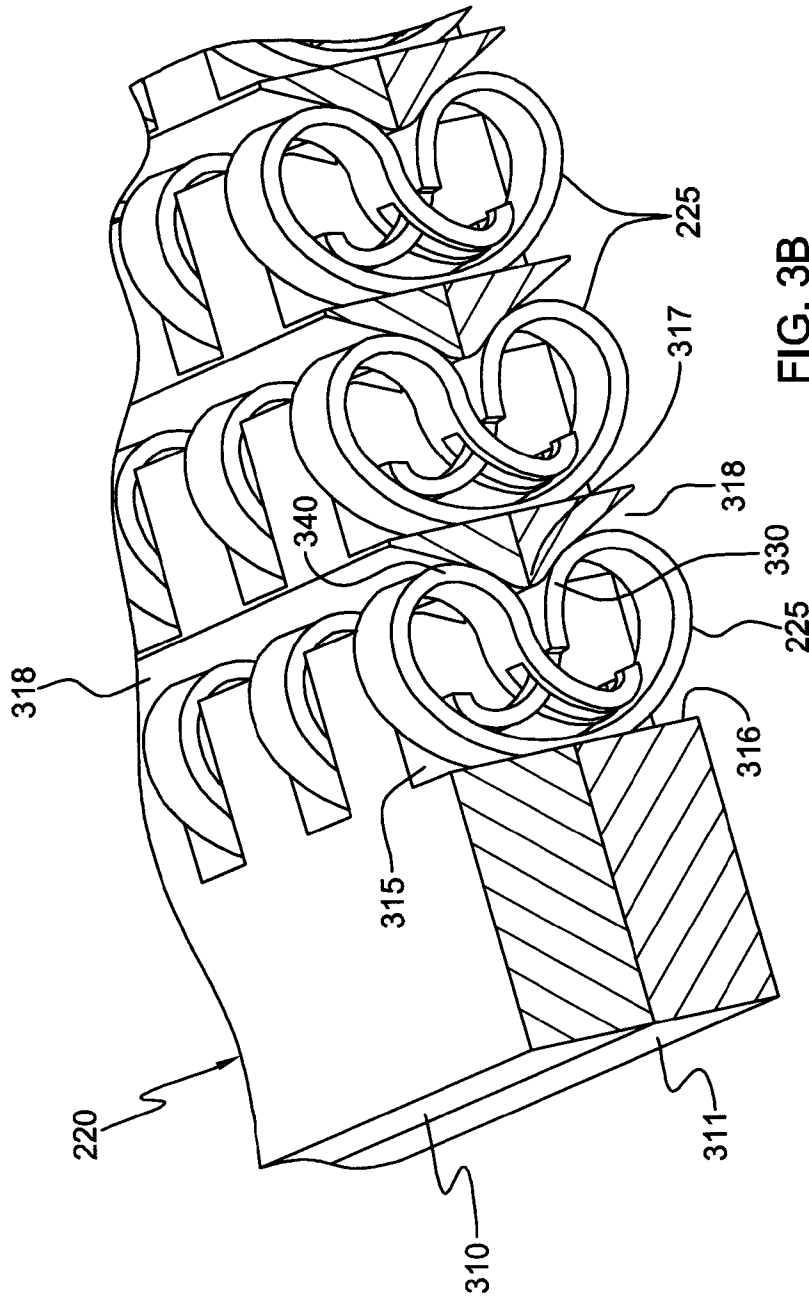

FIG. 3B

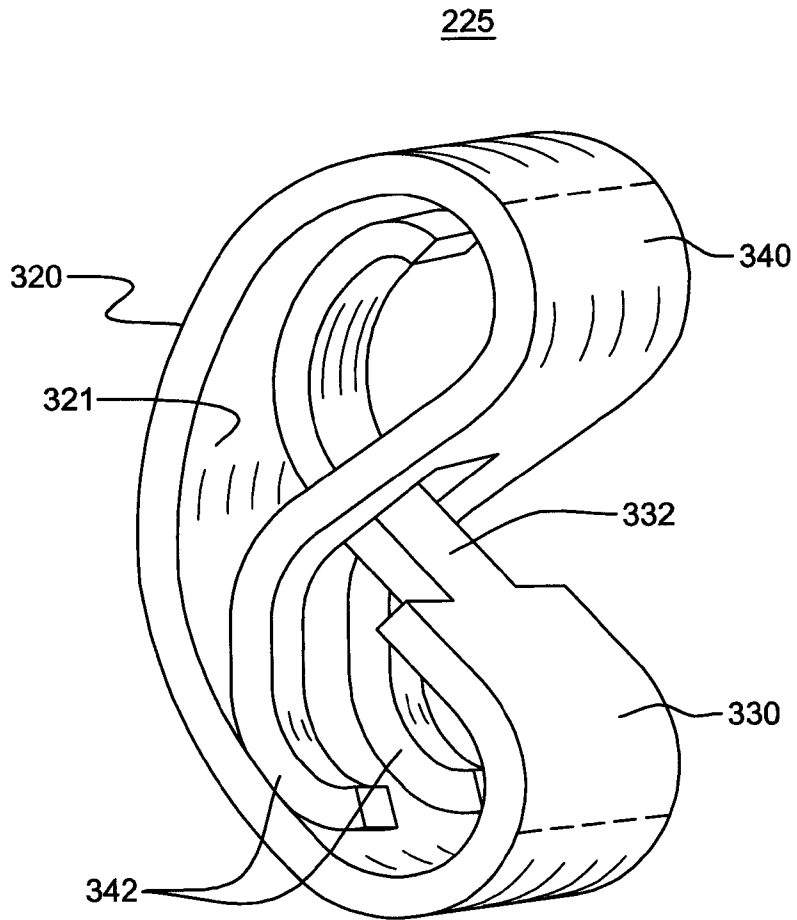

FIG. 3C



7/8

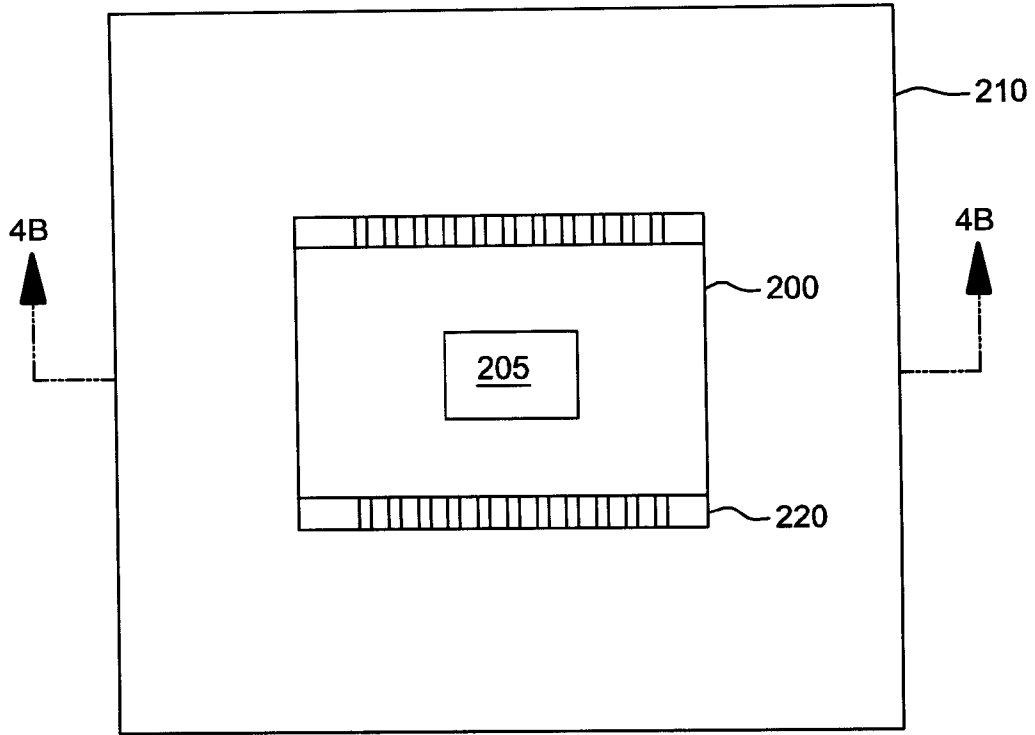

FIG. 4A

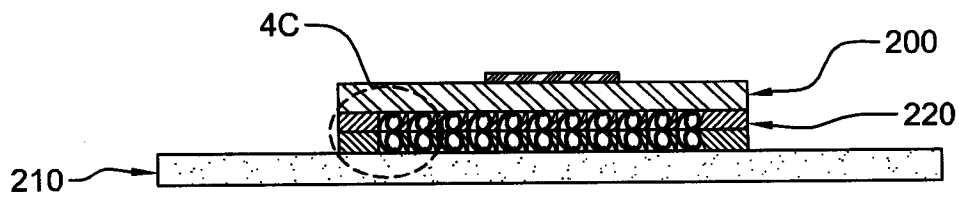

FIG. 4B

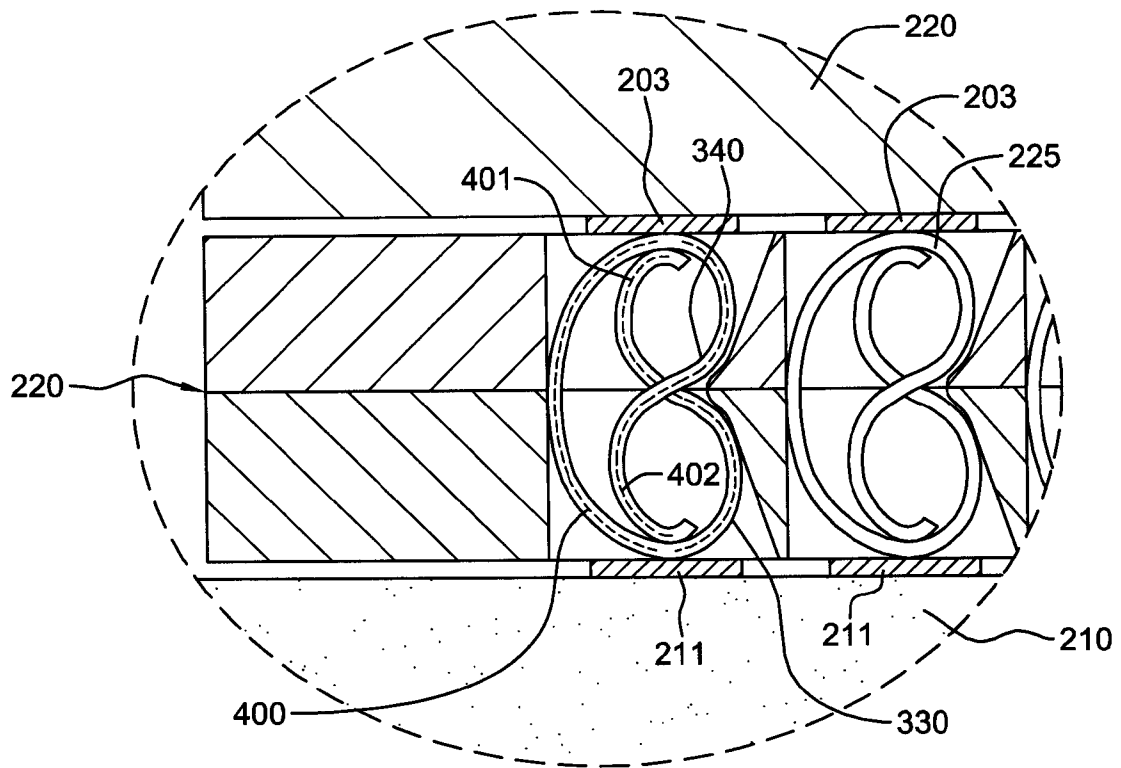

FIG. 4C

# INTERNATIONAL SEARCH REPORT

International application No.

PCT/IB2013/050082

## A. CLASSIFICATION OF SUBJECT MATTER

See the extra sheet

According to International Patent Classification (IPC) or to both national classification and IPC

## B. FIELDS SEARCHED

Minimum documentation searched (classification system followed by classification symbols)

IPC: H01R; H05K; H01L

Documentation searched other than minimum documentation to the extent that such documents are included in the fields searched

Electronic data base consulted during the international search (name of data base and, where practicable, search terms used)

CNPAT;DWPI;EPODOC;SIPOABS: INTERPOSER, SLIDABLE, LGA, SPRING, ELASTIC, CONTACT, COMPRESSIBLE, END, TERMINAL, SOCKET, CHIP, WIRING, BOARD, PACKAGE, PROTRUSION

## C. DOCUMENTS CONSIDERED TO BE RELEVANT

Category*	Citation of document, with indication, where appropriate, of the relevant passages	Relevant to claim No.
X	JP10125428A (YAMAICHI ELECTRIC CO., LTD.,)15 May 1998(15.05.1998) see paragraphs [0009]-[0026], figs1-14	1-20
A	US5957703A(HIROSE ELECTRIC CO.,LTD.,)28 Sep. 1999(28.09.1999) the whole document	1-20
A	US7255574B1(LOTES CO., LTD.,)14 Aug.2007 (14.08.2007) the whole document	1-20
A	WO2011072643A1 (WEBASTO AG)23 Jun.2011(23.06.2011) the whole document	1-20

Further documents are listed in the continuation of Box C.

See patent family annex.

<p>* Special categories of cited documents:</p> <p>“A” document defining the general state of the art which is not considered to be of particular relevance</p> <p>“E” earlier application or patent but published on or after the international filing date</p> <p>“L” document which may throw doubts on priority claim (S) or which is cited to establish the publication date of another citation or other special reason (as specified)</p> <p>“O” document referring to an oral disclosure, use, exhibition or other means</p> <p>“P” document published prior to the international filing date but later than the priority date claimed</p>	<p>“T” later document published after the international filing date or priority date and not in conflict with the application but cited to understand the principle or theory underlying the invention</p> <p>“X” document of particular relevance; the claimed invention cannot be considered novel or cannot be considered to involve an inventive step when the document is taken alone</p> <p>“Y” document of particular relevance; the claimed invention cannot be considered to involve an inventive step when the document is combined with one or more other such documents, such combination being obvious to a person skilled in the art</p> <p>“&amp;”document member of the same patent family</p>
--	--

Date of the actual completion of the international search  
08 May 2013 (08.05.2013)

Date of mailing of the international search report  
**30 May 2013 (30.05.2013)**

Name and mailing address of the ISA/CN  
The State Intellectual Property Office, the P.R.China  
6 Xitucheng Rd., Jimen Bridge, Haidian District, Beijing, China  
100088  
Facsimile No. 86-10-62019451

Authorized officer  
**WANG,Yanhua**  
Telephone No. (86-10)62414033

# INTERNATIONAL SEARCH REPORT

International application No.

PCT/IB2013/050082

## CLASSIFICATION OF SUBJECT MATTER:

H01R13/11(2006.01) i

H01R33/76(2006.01) i

H05K1/18(2006.01) n

**INTERNATIONAL SEARCH REPORT**  
Information on patent family members

International application No.  
PCT/IB2013/050082

Patent Documents referred in the Report	Publication Date	Patent Family	Publication Date
JP10125428A	15.05.1998	JP2912882B2	28.06.1999
US5957703A	28.09.1999	EP0867980A2	30.09.1998
		JP10228966A	25.08.1998
		TW352195U1	01.02.1999
US725574B1	14.08.2007	NONE	
WO2011072643A1	23.06.2011	KR20120079477A	12.07.2012
		MX2012006947A1	31.07.2012
		DE102009058825A1	04.08.2011
		CN102612866A	25.07.2012