



US00RE50307E

(19) **United States**
(12) **Reissued Patent**
Tsai

(10) **Patent Number:** **US RE50,307 E**
(45) **Date of Reissued Patent:** ***Feb. 18, 2025**

(54) **SOCKET STRUCTURE WITH DUPLEX ELECTRICAL CONNECTION**

(71) Applicant: **KIWI INTELLECTUAL ASSETS CORPORATION**, New Taipei (TW)

(72) Inventor: **Chou Hsien Tsai**, New Taipei (TW)

(73) Assignee: **KIWI INTELLECTUAL ASSETS CORPORATION**, New Taipei (TW)

(*) Notice: This patent is subject to a terminal disclaimer.

(21) Appl. No.: **17/974,866**

(22) Filed: **Oct. 27, 2022**

Related U.S. Patent Documents

Reissue of:

(64) Patent No.: **8,198,563**
Issued: **Jun. 12, 2012**
Appl. No.: **12/759,408**
Filed: **Apr. 13, 2010**

U.S. Applications:

(63) Continuation of application No. 17/020,359, filed on Sep. 14, 2020, now Pat. No. Re. 49,287, which is an application for the reissue of Pat. No. 8,198,563.

(30) **Foreign Application Priority Data**

Apr. 15, 2009 (TW) 098112573
May 26, 2009 (TW) 098117405
(Continued)

(51) **Int. Cl.**
H01R 27/00 (2006.01)
H01R 24/62 (2011.01)

(52) **U.S. Cl.**
CPC **H01R 27/00** (2013.01); **H01R 24/62** (2013.01)

(58) **Field of Classification Search**
CPC H01R 29/00; H01R 27/00; H01R 12/58; H01R 12/716; H01R 13/64; H01R 13/642;
(Continued)

(56) **References Cited**

U.S. PATENT DOCUMENTS

3,795,037 A 3/1974 Luttmer
3,808,577 A 4/1974 Mathauser
(Continued)

FOREIGN PATENT DOCUMENTS

CN 1370343 A 9/2002
CN 2616942 Y 5/2004
(Continued)

OTHER PUBLICATIONS

“Cannon Trident Connectors,” ITT Electronic Components, retrieved from <https://www.ittcannon.com>, 72 pages.

(Continued)

Primary Examiner — William E Dondero

(74) *Attorney, Agent, or Firm* — Jason H. Vick; Womble Bond Dickinson (US) LLP

(57) **ABSTRACT**

A socket structure includes a base; a slot, disposed on one end of the base and to be connected to one plug having one row of terminals; a tongue disposed on a front end of the base and within the slot so that chambers of the slot on two sides of the tongue may be normally and oppositely inserted and positioned into the slot; one row of first contacts separately arranged on one surface of the tongue, wherein each first contact is electrically connected to a first pin extending out of the base; and one row of second contacts separately arranged on the other surface of the tongue. Each second contact is electrically connected to a second pin extending out of the base. When the plug is inserted into the slot, the row of terminals of the plug are electrically connected to the row of first or second contacts.

102 Claims, 29 Drawing Sheets

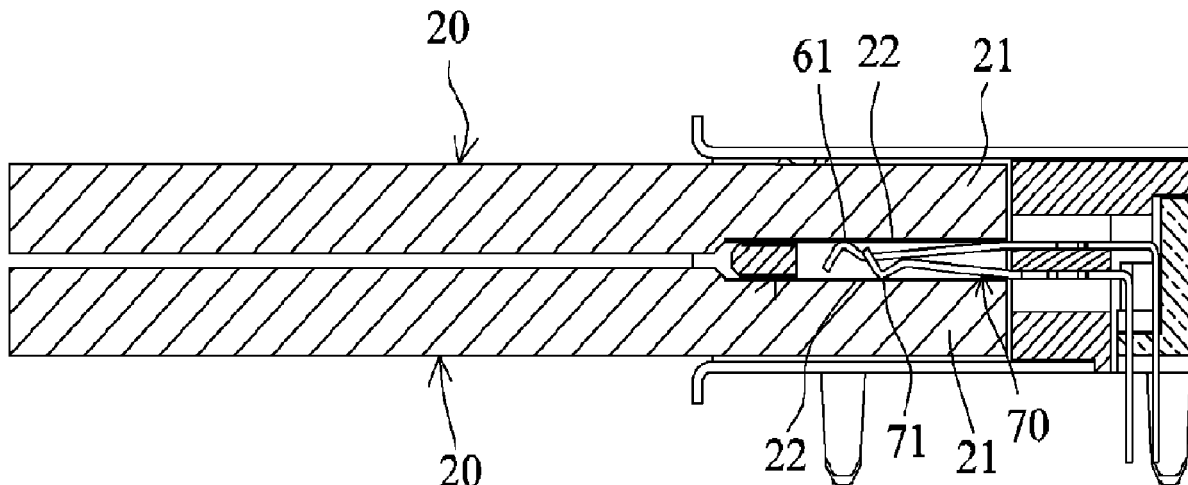

(30) Foreign Application Priority Data

Jun. 5, 2009 (TW) 098210021
 Jan. 13, 2010 (TW) 099100847

(58) Field of Classification Search

CPC H01R 13/658; H05K 5/0278; G06K
 19/07732

See application file for complete search history.

(56) References Cited

U.S. PATENT DOCUMENTS

3,810,258	A	5/1974	Mathauser	7,182,646	B1	2/2007	Chou et al.
4,253,719	A	3/1981	Meginley	7,198,522	B1	4/2007	Ho et al.
4,258,969	A	3/1981	Stallard	7,249,978	B1	7/2007	Ni
4,421,371	A	12/1983	Clark et al.	7,269,004	B1	9/2007	Ni et al.
4,537,459	A	8/1985	Brennan et al.	7,275,940	B2	10/2007	Chen
4,700,998	A	10/1987	Hvezda et al.	7,300,320	B2	11/2007	Lee
4,822,303	A	4/1989	Nakamura et al.	7,314,383	B1	1/2008	Ho et al.
5,135,406	A	8/1992	Ishikawa	7,318,752	B2 *	1/2008	Fujimoto et al. 439/660
5,293,013	A	3/1994	Takahashi	7,329,128	B1	2/2008	Awad
5,295,843	A	3/1994	Davis et al.	7,341,458	B1	3/2008	Koh
5,431,578	A	7/1995	Wayne	7,347,747	B2	3/2008	Shimizu
5,445,528	A	8/1995	Frantz	7,352,601	B1	4/2008	Minneman et al.
5,496,186	A	3/1996	Dobbelaere et al.	7,354,314	B1	4/2008	Sprouse et al.
5,518,416	A	5/1996	Kantner et al.	7,359,208	B2 *	4/2008	Ni 361/752
5,542,850	A	8/1996	Frantz	7,361,059	B2 *	4/2008	Harkabi et al. 439/660
5,591,050	A	1/1997	Sueoka	7,363,947	B2	4/2008	Teicher
5,595,503	A	1/1997	Pittman et al.	7,387,539	B2	6/2008	Trenne
5,644,470	A	7/1997	Benedict et al.	7,402,086	B2	7/2008	Pomerantz et al.
5,772,448	A	6/1998	Ekrot et al.	7,407,390	B1	8/2008	Ni
5,773,901	A	6/1998	Kantner	7,416,413	B2	8/2008	Liao
5,800,220	A	9/1998	Feeny et al.	7,440,286	B2	10/2008	Hiew et al.
5,941,729	A	8/1999	Sri-jayantha	7,440,287	B1 *	10/2008	Ni et al. 361/752
5,964,610	A	10/1999	Mccooy	7,458,825	B2	12/2008	Atsmon et al.
6,033,247	A	3/2000	Gregory	7,462,071	B1	12/2008	Wu
6,074,225	A	6/2000	Wu et al.	7,465,181	B1	12/2008	Bridges et al.
6,095,861	A	8/2000	Lin et al.	7,467,977	B1	12/2008	Yi et al.
6,127,941	A	10/2000	Van	7,470,160	B1	12/2008	Mostoller et al.
6,132,223	A	10/2000	Seeley et al.	7,500,861	B2	3/2009	Harkabi et al.
6,132,254	A	10/2000	Wu	7,517,253	B1	4/2009	Chiang
6,190,190	B1	2/2001	Daly et al.	7,547,218	B2	6/2009	Hiew et al.
6,257,930	B1	7/2001	Yu	7,553,172	B2	6/2009	Chiu et al.
6,352,450	B1	3/2002	Bronk et al.	7,572,153	B2	8/2009	Trenne
6,364,699	B1	4/2002	Hwang et al.	7,591,657	B2	9/2009	Teicher
6,394,813	B1	5/2002	Stout et al.	7,601,034	B1	10/2009	Aekins et al.
6,417,718	B1	7/2002	Ota	7,604,512	B1	10/2009	Chen
6,461,192	B1	10/2002	Kwoka	7,628,619	B2	12/2009	Chuang
6,530,793	B2	3/2003	Eichhorn et al.	7,628,655	B1	12/2009	Chen
6,544,075	B1	4/2003	Liao	7,635,280	B1	12/2009	Crumlin et al.
6,565,366	B1	5/2003	Wu	7,641,519	B1	1/2010	Chen
6,599,152	B1	7/2003	Oliphant et al.	7,654,871	B2	2/2010	Yi et al.
6,609,928	B1	8/2003	Le	7,670,156	B2 *	3/2010	Chen 439/108
6,744,634	B2	6/2004	Yen	7,682,169	B2	3/2010	Park et al.
6,792,487	B2	9/2004	Kao	7,710,736	B2	5/2010	Middlekauff et al.
6,796,844	B1	9/2004	Edwards	7,731,535	B1	6/2010	Wan et al.
6,840,806	B2	1/2005	Kodama	7,740,499	B1	6/2010	Willey et al.
6,854,984	B1	2/2005	Lee et al.	7,918,689	B2	4/2011	Sloey et al.
6,887,108	B2	5/2005	Wu	8,043,099	B1	10/2011	Ni et al.
6,901,457	B1	5/2005	Toombs et al.	8,073,985	B1	12/2011	Ni et al.
6,948,983	B1	9/2005	Peng	8,079,879	B2	12/2011	Chiang
6,962,510	B1	11/2005	Chen et al.	8,167,638	B2	5/2012	Wojcik et al.
6,964,582	B2	11/2005	Zhuang et al.	8,198,563	B2	6/2012	Tsai
6,971,915	B1	12/2005	Mao et al.	8,241,047	B2	8/2012	Ni et al.
6,981,887	B1	1/2006	Mese et al.	8,257,287	B2	9/2012	Hanlon et al.
6,991,483	B1	1/2006	Milan et al.	8,328,434	B2	12/2012	Wang et al.
7,001,192	B1	2/2006	Yeh	RE49,287	E	11/2022	Tsai
7,001,201	B1	2/2006	Peng	2003/0100203	A1	5/2003	Yen
7,037,120	B1	5/2006	Yeh	2003/0171035	A1	9/2003	Yoo
7,059,914	B2	6/2006	Tsai	2004/0023559	A1	2/2004	Wu
7,090,541	B1	8/2006	Ho	2004/0023560	A1	2/2004	Swoboda
7,094,086	B2	8/2006	Teicher	2004/0103228	A1	5/2004	Kao
7,094,089	B2	8/2006	Andre et al.	2004/0115990	A1	6/2004	Kodama
7,150,651	B1	12/2006	Yuan et al.	2005/0079738	A1	4/2005	Ahn
7,155,545	B1	12/2006	Wang	2005/0124218	A1	6/2005	Chen et al.
7,160,125	B1	1/2007	Teicher	2005/0186810	A1	8/2005	Sardella et al.
7,165,998	B2	1/2007	Lee et al.	2005/0186850	A1	8/2005	Tsai
				2006/0024997	A1	2/2006	Teicher
				2006/0056401	A1	3/2006	Bohm et al.
				2006/0094301	A1	5/2006	Lee et al.
				2006/0183371	A1	8/2006	Tsai
				2007/0010115	A1	1/2007	Teicher
				2007/0049115	A1	3/2007	Igarashi et al.
				2007/0058332	A1	3/2007	Canterbury et al.
				2007/0072491	A1	3/2007	Huang
				2007/0173129	A1	7/2007	Han
				2007/0197053	A1	8/2007	Liao
				2007/0202725	A1	8/2007	Teicher
				2007/0202750	A1	8/2007	Nishiwaki et al.
				2007/0243726	A1	10/2007	Trenne et al.
				2007/0281524	A1	12/2007	Pomerantz

(56)

References Cited

U.S. PATENT DOCUMENTS

2007/0300023 A1 12/2007 Cronin et al.
 2008/0030963 A1 2/2008 Middlekauff et al.
 2008/0064271 A1 3/2008 Hiew et al.
 2008/0067248 A1 3/2008 Hiew et al.
 2008/0119076 A1 5/2008 Teicher
 2008/0130207 A1 6/2008 Schmidt
 2008/0200072 A1 8/2008 Cheong
 2008/0218799 A1 9/2008 Hiew et al.
 2008/0242149 A1 10/2008 Konno et al.
 2008/0254680 A1 10/2008 Chiu et al.
 2008/0274633 A1 11/2008 Teicher
 2008/0299833 A1 12/2008 Abe
 2008/0305651 A1 12/2008 Mostoller et al.
 2008/0311781 A1 12/2008 Wojcik et al.
 2009/0011621 A1 1/2009 Trenne
 2009/0017683 A1 1/2009 Lin
 2009/0042421 A1 2/2009 Zheng et al.
 2009/0156055 A1 6/2009 Park et al.
 2009/0176386 A1 7/2009 Wu
 2009/0258539 A1* 10/2009 Zheng et al. 439/607.41
 2009/0318026 A1 12/2009 Yi et al.
 2010/0075517 A1 3/2010 Ni et al.
 2010/0081337 A1 4/2010 Dorogusker et al.
 2010/0190382 A1 7/2010 Szini et al.
 2010/0221936 A1 9/2010 Zhao et al.

FOREIGN PATENT DOCUMENTS

CN 2653739 Y 11/2004
 CN 2682604 Y 3/2005
 CN 2682660 Y 3/2005
 CN 2682675 Y 3/2005
 CN 2728025 Y 9/2005
 CN 2733636 Y 10/2005
 CN 1734857 A 2/2006
 CN 2791923 Y 6/2006
 CN 1830122 A 9/2006
 CN 2884567 Y 3/2007
 CN 1969428 A 5/2007
 CN 2909592 Y 6/2007
 CN 101015096 A 8/2007
 CN 101091292 A 12/2007
 CN 101103498 A 1/2008
 CN 101136524 A 3/2008
 CN 201038524 Y 3/2008
 CN 201038533 A 3/2008
 CN 101227046 A 7/2008
 CN 201113076 Y 9/2008
 CN 201113094 Y 9/2008
 CN 201142484 Y 10/2008
 CN 201160164 Y 12/2008
 CN 201181784 Y 1/2009
 CN 101364678 A 2/2009
 CN 201204298 Y 3/2009
 CN 101419829 A 4/2009
 CN 201303129 Y 9/2009
 CN 201312013 Y 9/2009
 CN 201315398 Y 9/2009
 CN 201319419 Y 9/2009
 CN 201319420 Y 9/2009
 CN 101557059 A 10/2009
 CN 201332168 Y 10/2009
 CN 201340920 Y 11/2009
 CN 201345463 Y 11/2009
 CN 201345464 Y 11/2009
 CN 201352641 Y 11/2009
 CN 201360013 Y 12/2009
 CN 201365045 Y 12/2009
 CN 201369403 Y 12/2009
 CN 201369488 Y 12/2009
 CN 201374421 Y 12/2009
 CN 201378641 Y 1/2010
 CN 201402869 Y 2/2010
 CN 201402876 Y 2/2010
 CN 201413880 Y 2/2010

CN 101677157 A 3/2010
 CN 101677158 A 3/2010
 CN 201440482 U 4/2010
 CN 201450136 U 5/2010
 CN 201450137 U 5/2010
 CN 201478488 U 5/2010
 CN 201478490 U 5/2010
 CN 201478491 U 5/2010
 CN 201478495 U 5/2010
 CN 201478578 U 5/2010
 CN 201490374 U 5/2010
 CN 201490376 U 5/2010
 CN 201490377 U 5/2010
 CN 101728722 A 6/2010
 CN 101728736 A 6/2010
 CN 201498671 U 6/2010
 CN 201508936 U 6/2010
 CN 201515047 U 6/2010
 CN 201515048 U* 6/2010
 CN 201515090 U 6/2010
 CN 201533031 U 7/2010
 CN 101800370 A 8/2010
 CN 201540989 U 8/2010
 CN 201540991 U 8/2010
 CN 201549671 U 8/2010
 CN 201562785 U 8/2010
 CN 201570618 U 9/2010
 CN 201594633 U 9/2010
 CN 101859936 A 10/2010
 CN 101877441 A 11/2010
 CN 101882716 A 11/2010
 CN 201656016 U 11/2010
 CN 201663252 U 12/2010
 CN 201663254 U 12/2010
 CN 201682065 U 12/2010
 CN 201708282 U 1/2011
 CN 201717389 U 1/2011
 CN 102013587 A 4/2011
 CN 102025052 A 4/2011
 CN 201812961 U 4/2011
 CN 201838763 U 5/2011
 CN 202084669 U 12/2011
 CN 202121098 U 1/2012
 DE 10034613 A1 1/2002
 JP 2003-217728 A 7/2003
 JP 4035779 B2 1/2008
 JP 2008-508694 A 3/2008
 JP 2008-210674 A 9/2008
 JP 2008-300091 A 12/2008
 JP 2009-043717 A 2/2009
 KR 10-2007-0039956 A 4/2007
 TW M 253969 U 12/2004
 WO WO 02/43192 A2 5/2002
 WO WO 2005/013436 A1 2/2005
 WO WO 2006/065681 A1 6/2006
 WO WO 2006/074348 A1 7/2006
 WO WO 2008/065659 A2 6/2008
 WO WO 2008/121731 A1 10/2008
 WO WO 2009/069969 A2 6/2009

OTHER PUBLICATIONS

“Department of Defense Interface Standard Aircraft/Store Electrical Interconnection System,” Department of Defense, Report MIL-STD-1760E, Oct. 24, 2007, 219 pages.
 “Why are so many plugs (USB, HDMI, Ethernet) asymmetrical?,” Post by u/boomybx on Reddit, 2014, retrieved from reddit.com/r/askscience/comments/1lsjfk/why_are_so_many_plugs_usb_hdmi_ethernet/, 12 pages.
 Shankland “Intel’s Light Peak: One PC cable to rule them all,” CNET, 2009, retrieved from https://www.cnet.com/news/intels-light-peak-one-pc-cable-to-rule-them-all/, 4 pages.
 Willington, “Flipper USB Enables Upside-Down USB Connections,” HotHardware, Jul. 15, 2010, retrieved from https://hothardware.com/news/flipper-usb-enables-upside-down-usb-connections.
 Patent Registration Information and List of References in German Patent Publication No. 102010014793.1, accurate as of Jul. 21, 2020, 2 pages.

(56)

References Cited

OTHER PUBLICATIONS

Patent Registration Information and List of References in German Patent Publication No. 202010017854.1, accurate as of Jul. 21, 2020, 2 pages.

Official Action (with English translation) for Japanese Patent Application No. 2010-091610, dated Jul. 12, 2010, 2 pages.

Official Action (with English translation) for Japanese Patent Application No. 2012-002496, dated May 31, 2012, 4 pages.

Official Action (with English translation) for Korean Patent Application No. 2010-0034310, dated Jul. 27, 2011, 4 pages.

Official Action (with English translation) for Korean Patent Application No. 2010-0034310, dated Nov. 30, 2011, 4 pages.

Official Action (with English translation) for Korean Patent Application No. 2010-0034310, dated May 18, 2012, 2 pages.

Unpublished Taiwanese Patent Application No. 098117405 (no English translation available), filed May 26, 2009, 38 pages.

Unpublished Taiwanese Patent Application No. 099100847 (no English translation available), filed Jan. 13, 2010, 53 pages.

Bibliographic Data and Prosecution History (with English mechanical translation) for Taiwanese Patent Application No. 098210021, first published Jun. 5, 2009, 17 pages.

Bibliographic Data and Prosecution History (with English mechanical translation) for Taiwanese Patent Application No. 099108987, first published Oct. 16, 2010, 107 pages.

Bibliographic Data and Prosecution History (with English mechanical translation) for Taiwanese Patent Application No. 099224051, first published Nov. 11, 2011, 150 pages.

Bibliographic Data and Prosecution History (with English mechanical translation) for Taiwanese Patent Application No. 100203503, first published Nov. 11, 2011, 69 pages.

Bibliographic Data and Prosecution History (with English mechanical translation) for Taiwanese Patent Application No. 099225602, first published Apr. 1, 2012, 78 pages.

Bibliographic Data and Prosecution History (with English mechanical translation) for Taiwanese Patent Application No. 101208435, first published Dec. 11, 2012, 116 pages.

Official Action for U.S. Appl. No. 12/759,408, dated Oct. 17, 2011, 5 pages. Restriction Requirement.

Official Action for U.S. Appl. No. 12/759,408, dated Dec. 7, 2011, 11 pages.

Notice of Allowance for U.S. Appl. No. 12/759,408, dated Mar. 16, 2012, 6 pages.

Office Action for U.S. Appl. No. 17/020,359, mailed Jan. 11, 2022.

Notice of Allowance for U.S. Appl. No. 17/020,359, mailed Aug. 17, 2022.

* cited by examiner

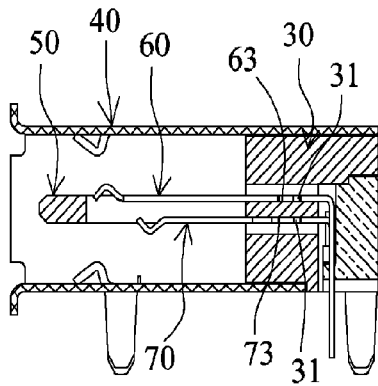

FIG. 6

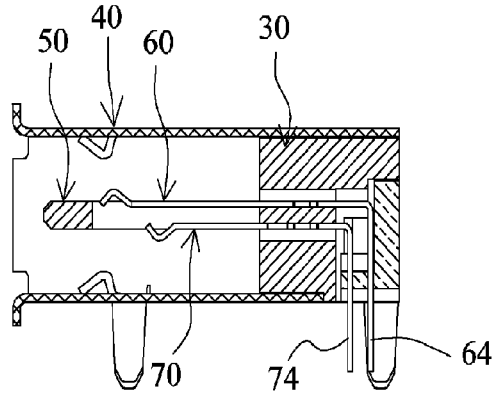

FIG. 7

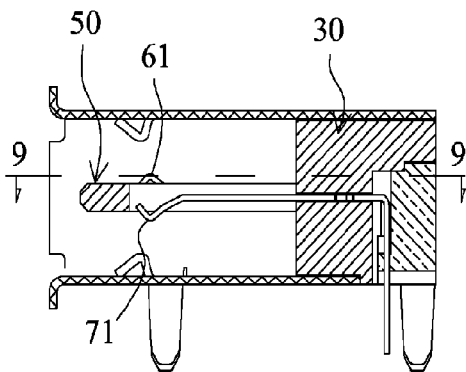

FIG. 8

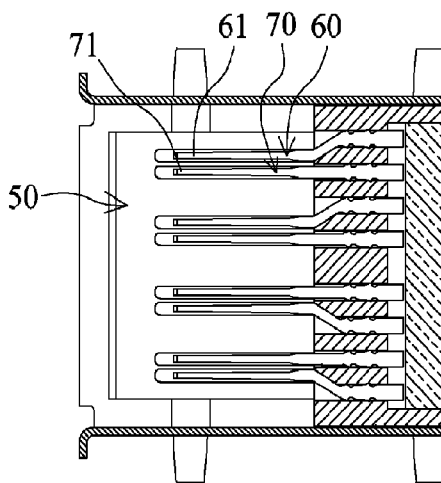

FIG. 9

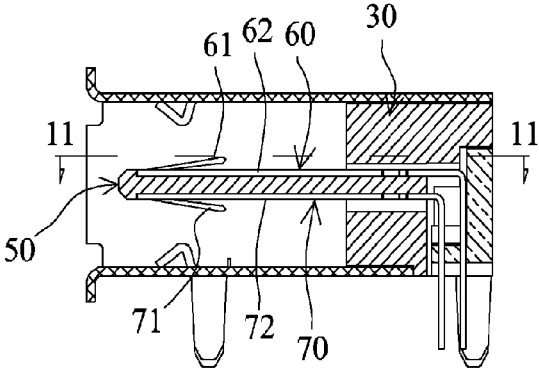

FIG. 10

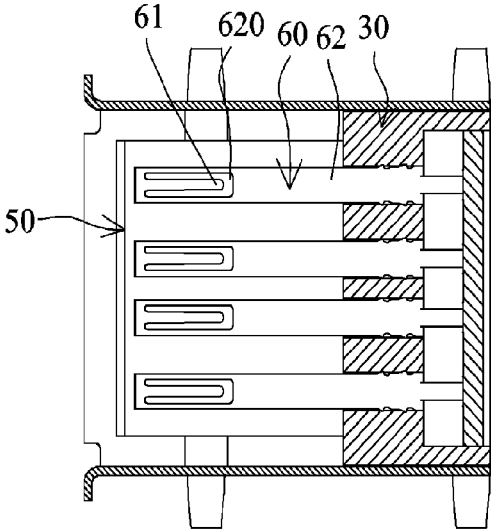

FIG. 11

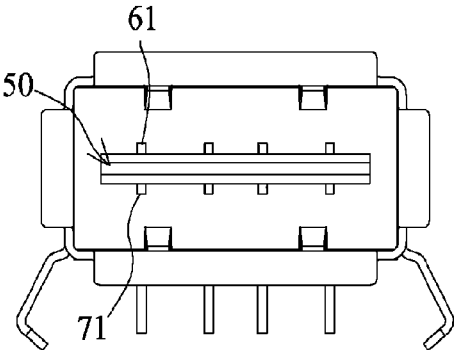

FIG. 12

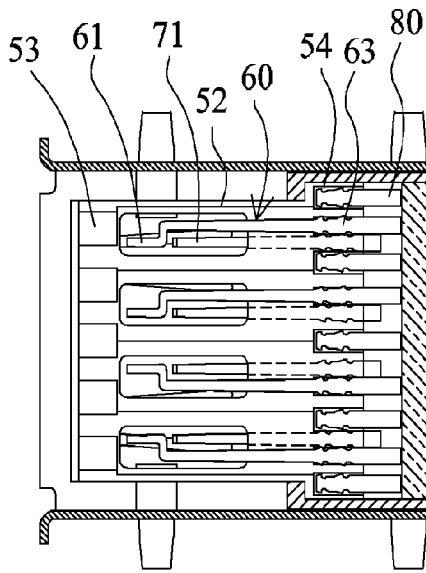

FIG. 14

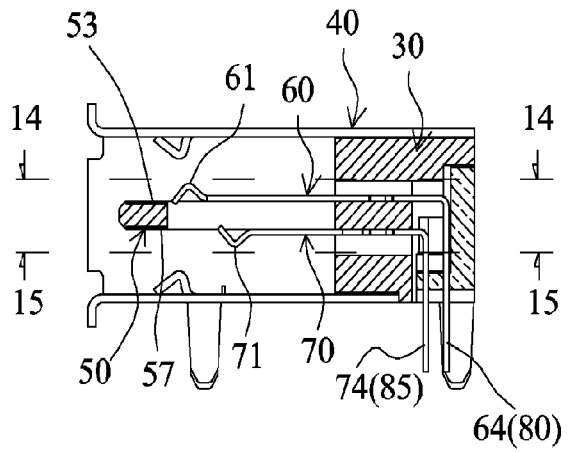

FIG. 13

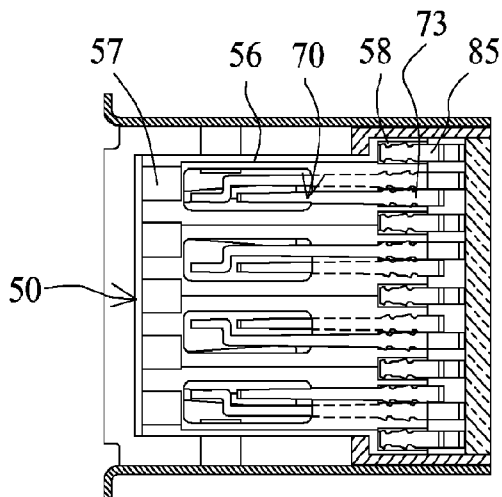

FIG. 15

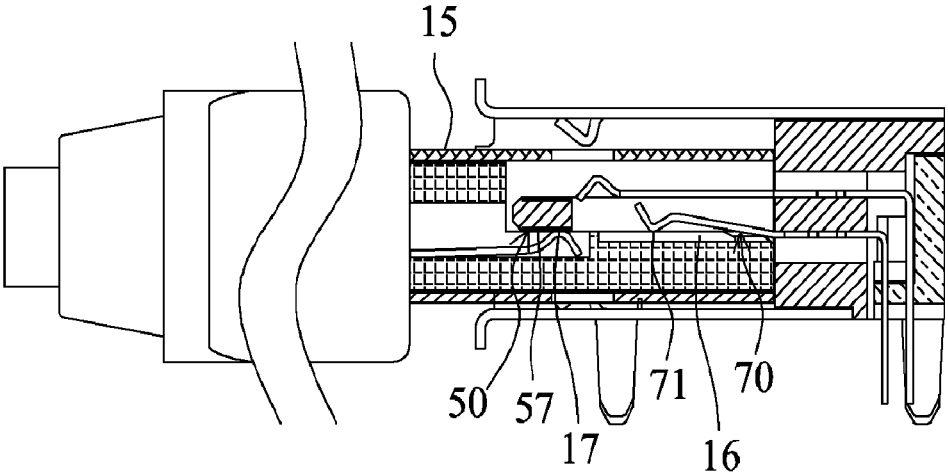

FIG. 16

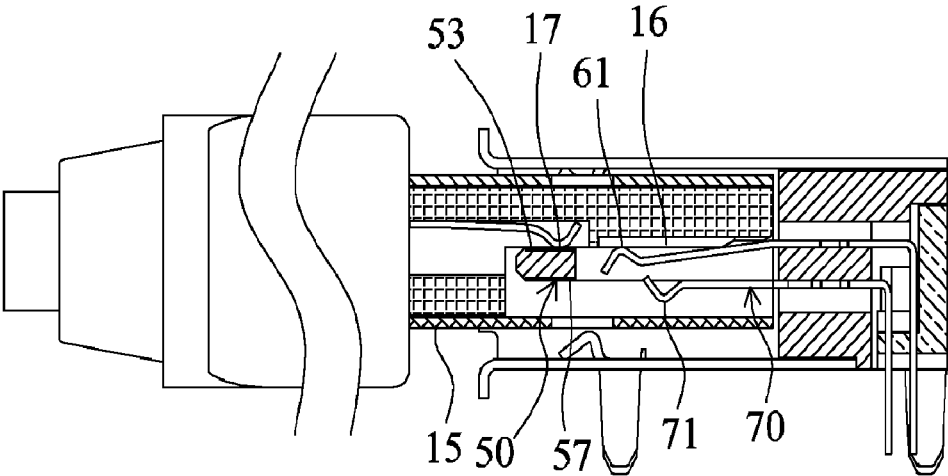

FIG. 17

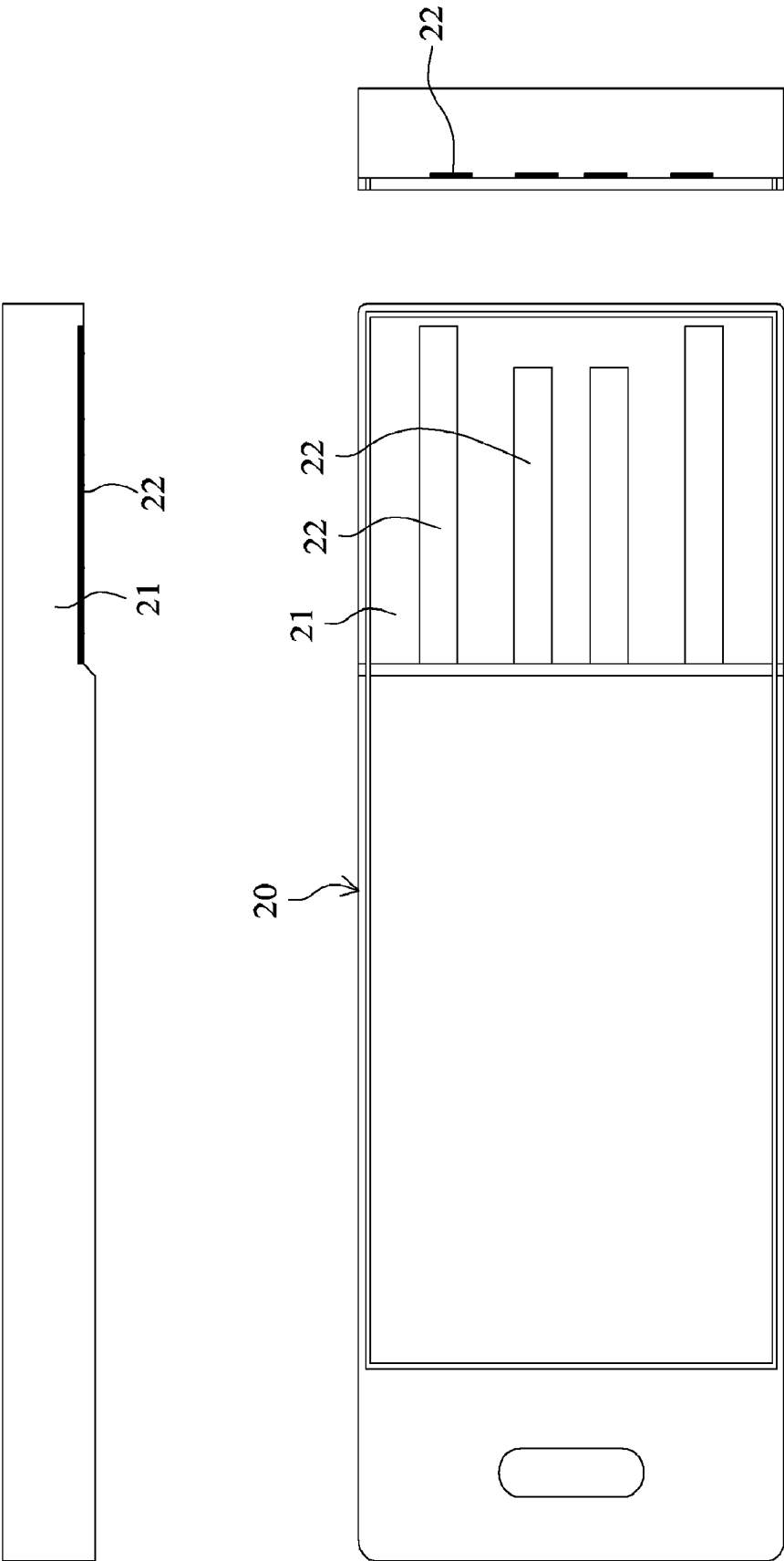

FIG. 18

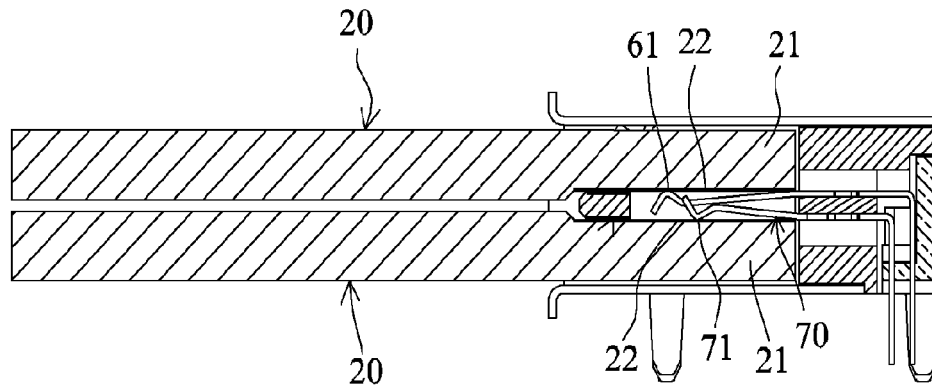

FIG. 19

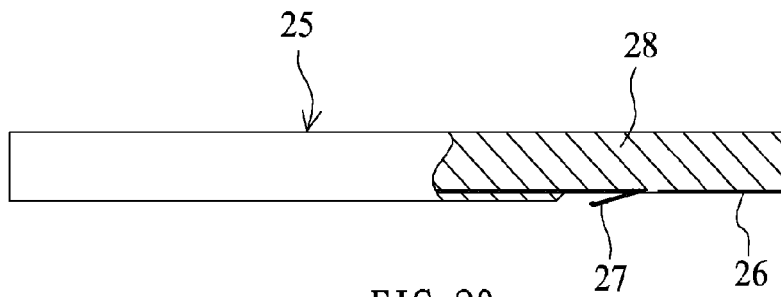

FIG. 20

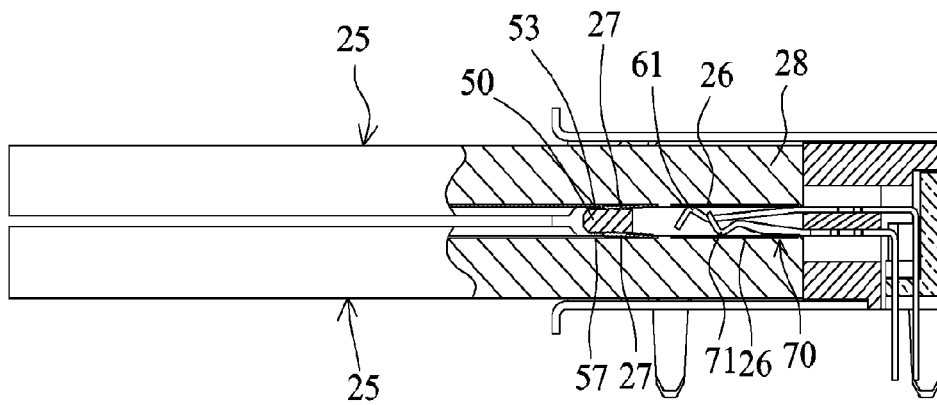

FIG. 21

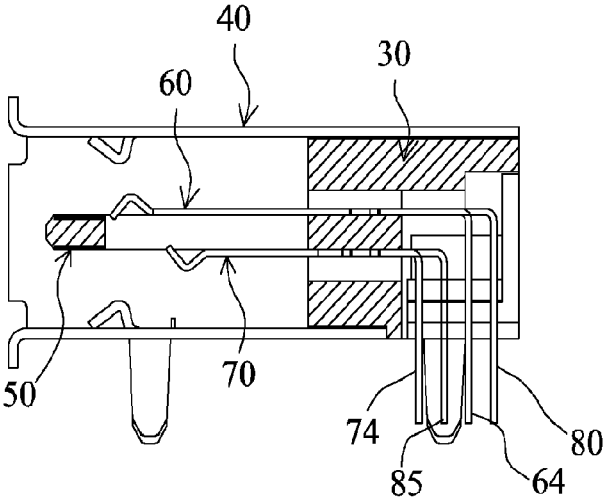

FIG. 22

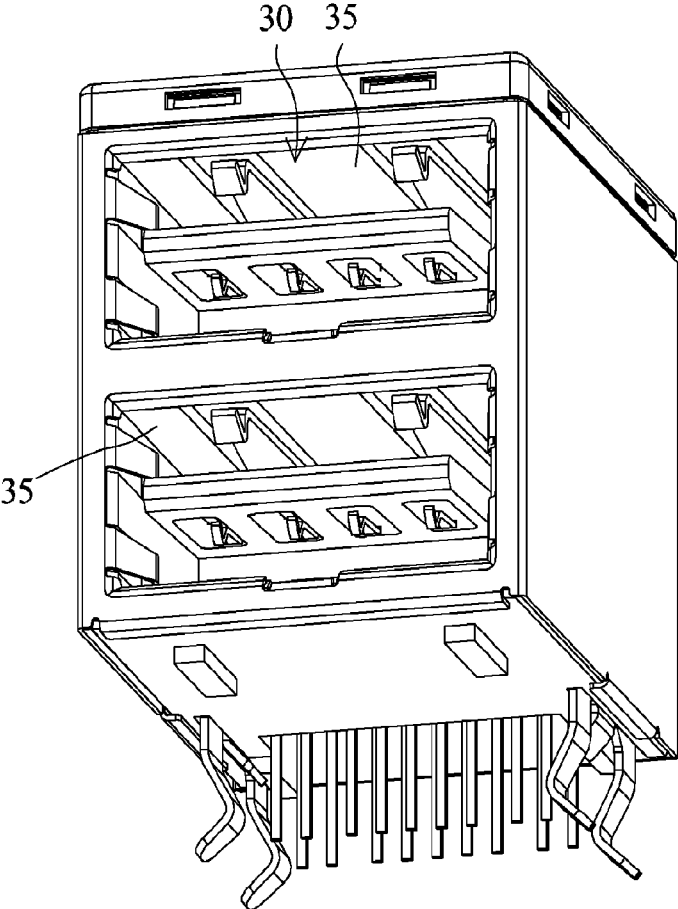

FIG. 23

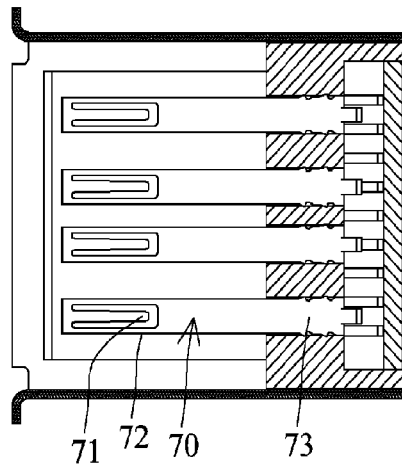

FIG. 26

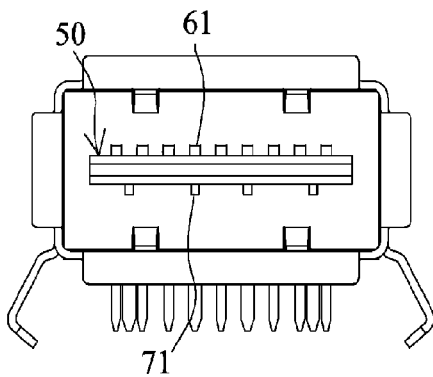

FIG. 25

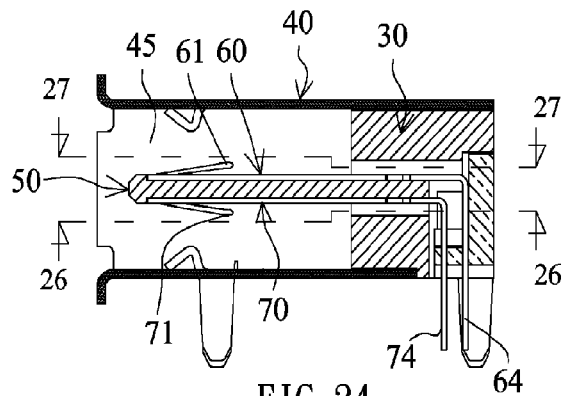

FIG. 24

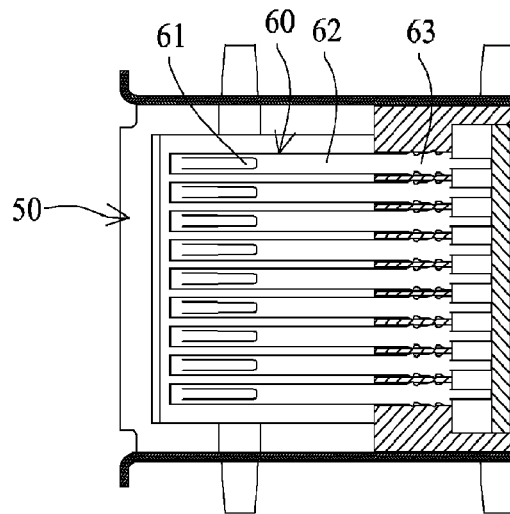

FIG. 27

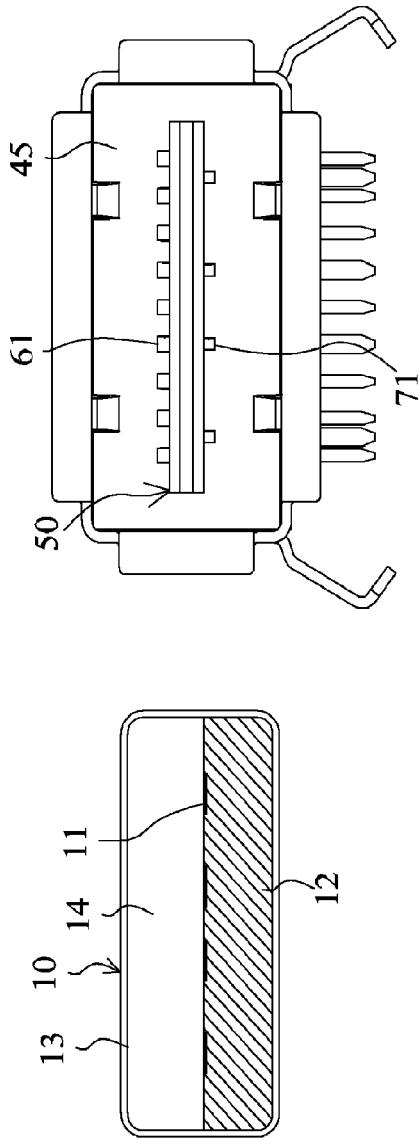

FIG. 28

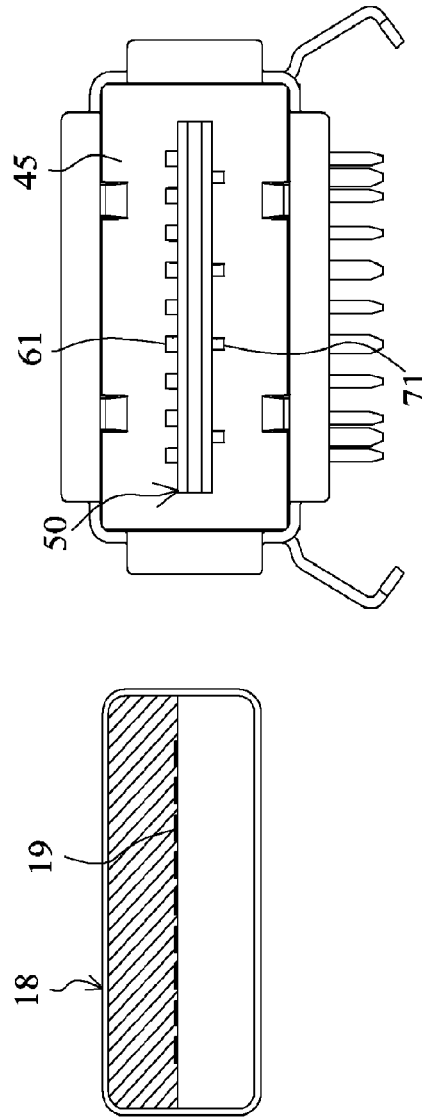

FIG. 29

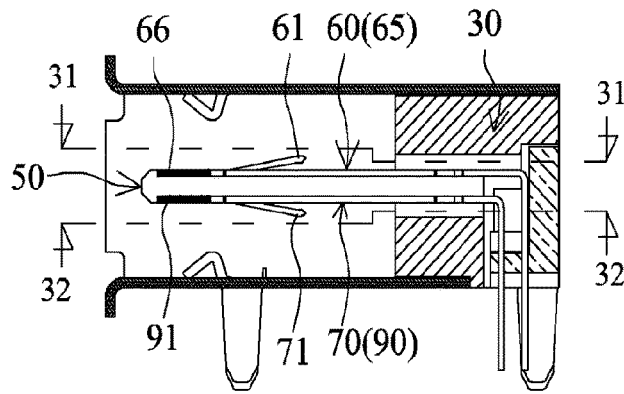

FIG. 30

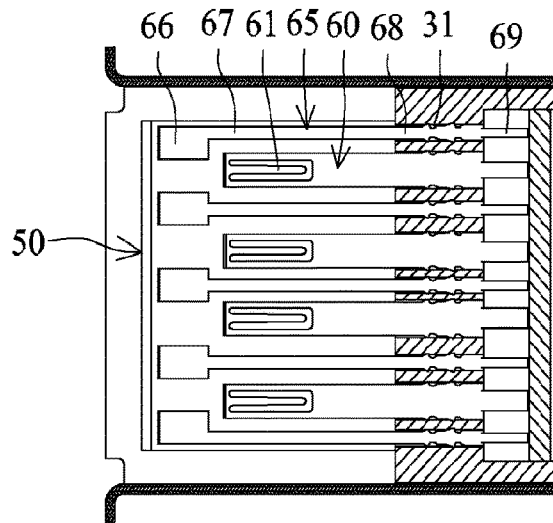

FIG. 31

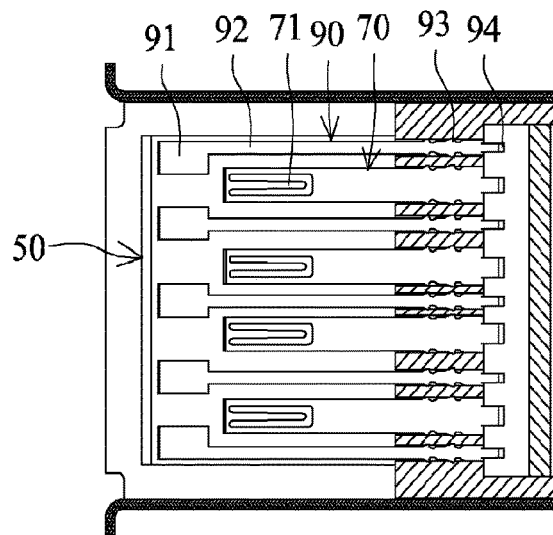

FIG. 32

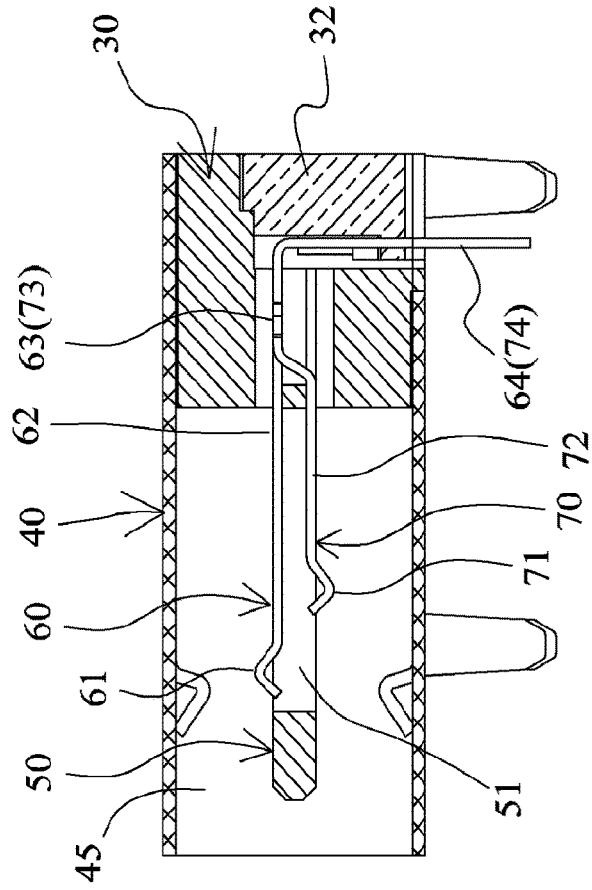

FIG. 34

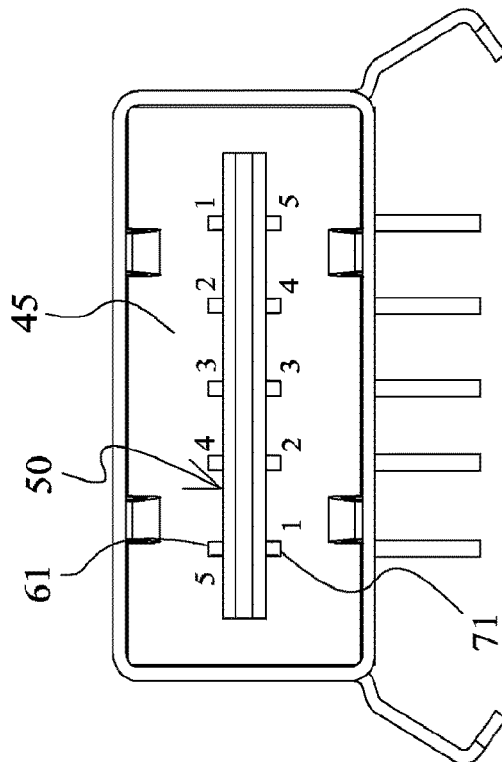
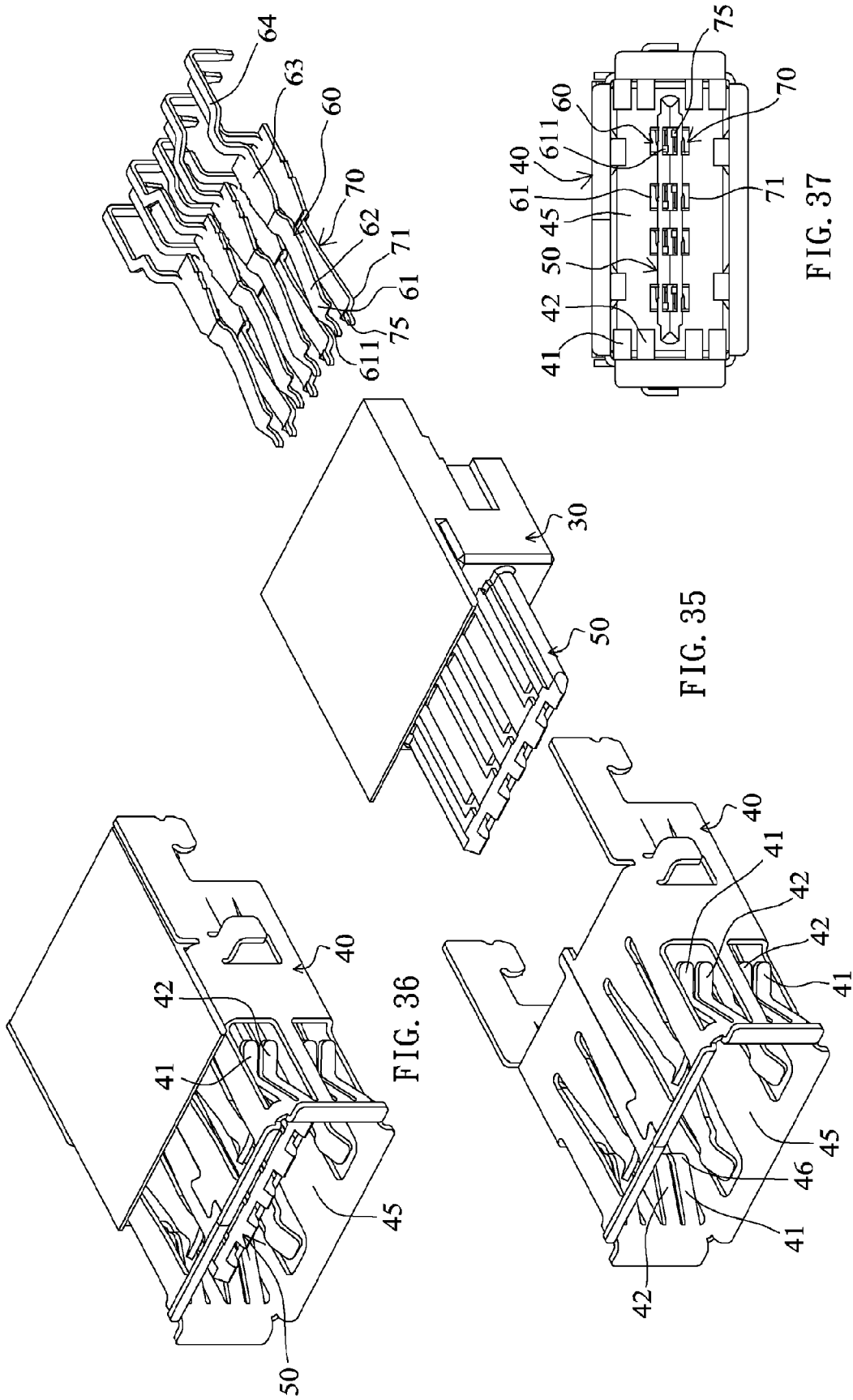

FIG. 33



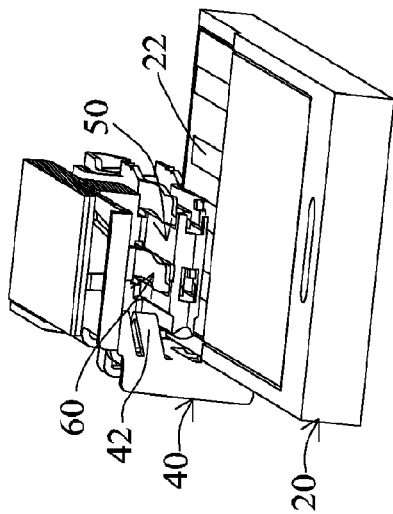

FIG. 38

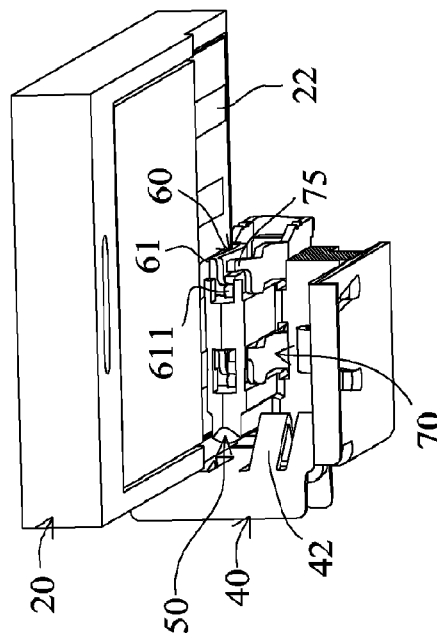

FIG. 39

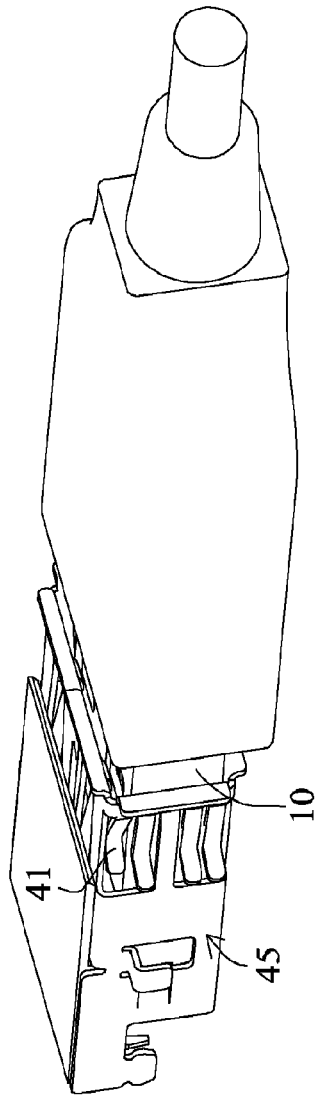

FIG. 40

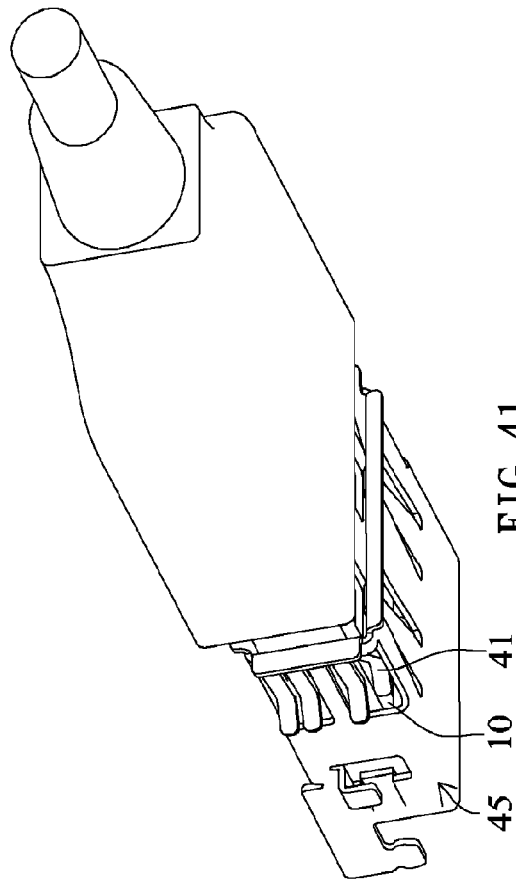

FIG. 41

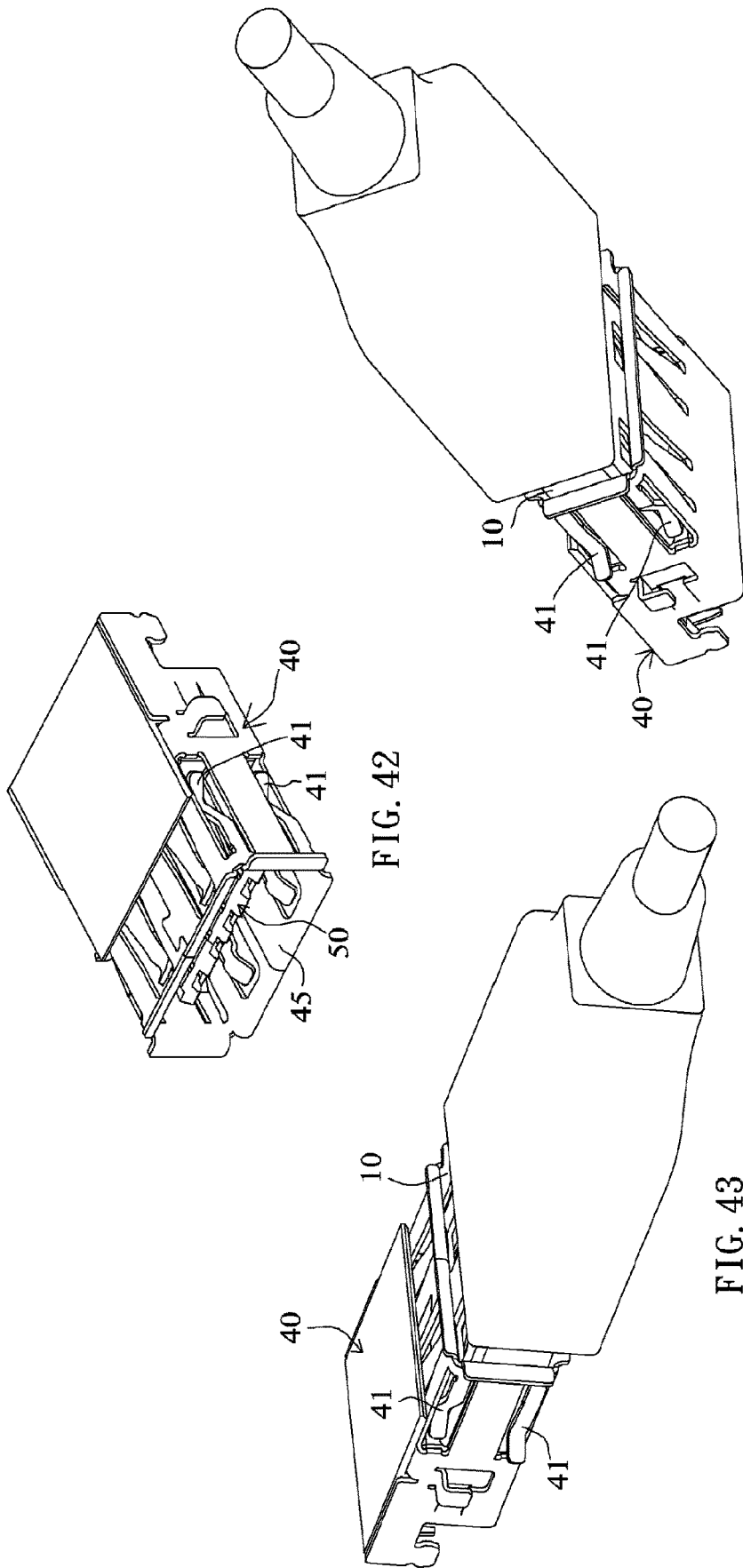

FIG. 42

FIG. 43

FIG. 44

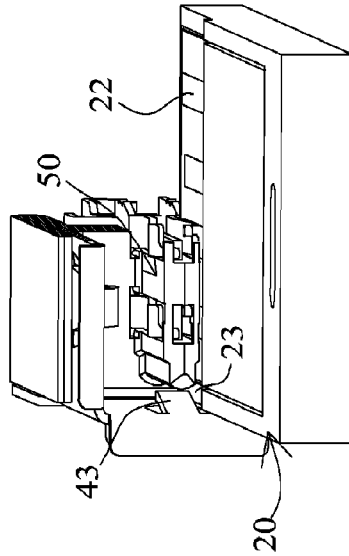
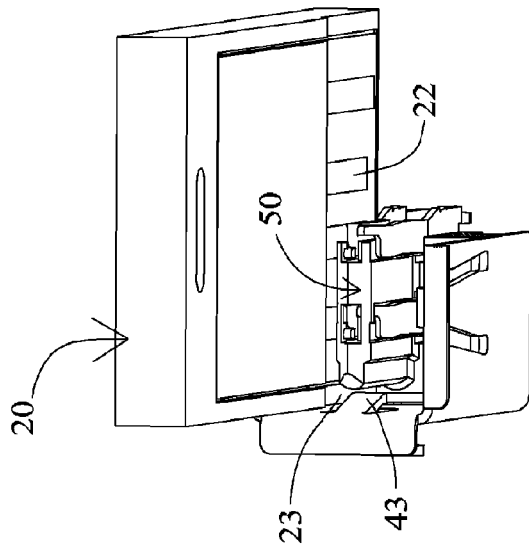
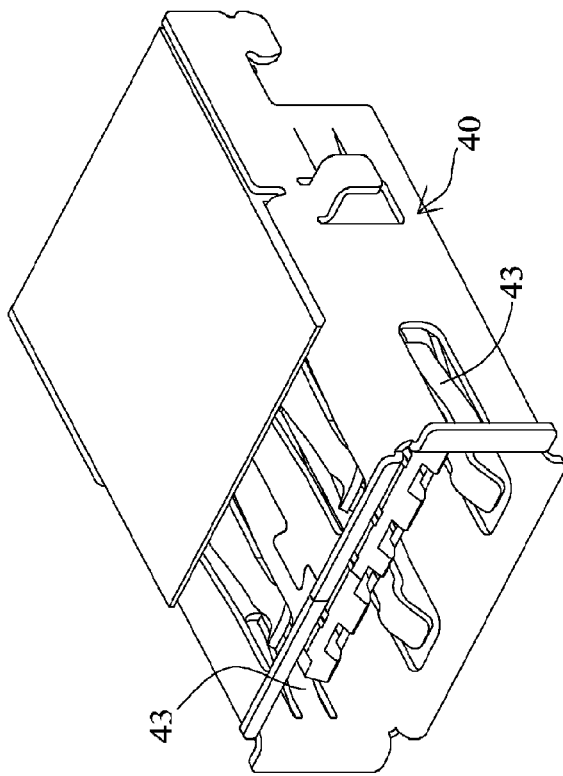

FIG. 45

FIG. 47

FIG. 46

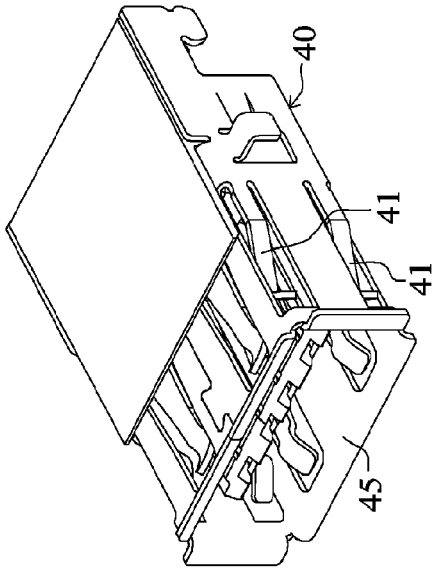

FIG. 48

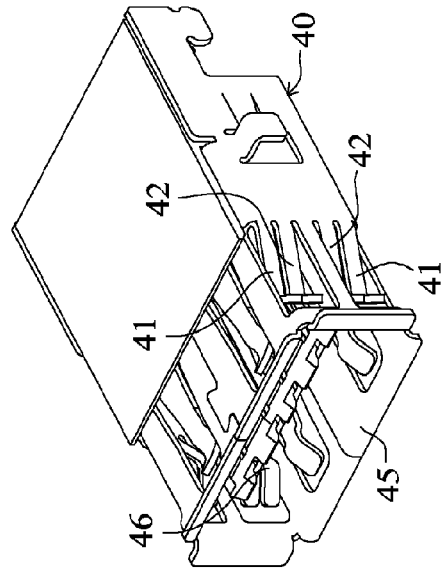

FIG. 49

FIG. 50

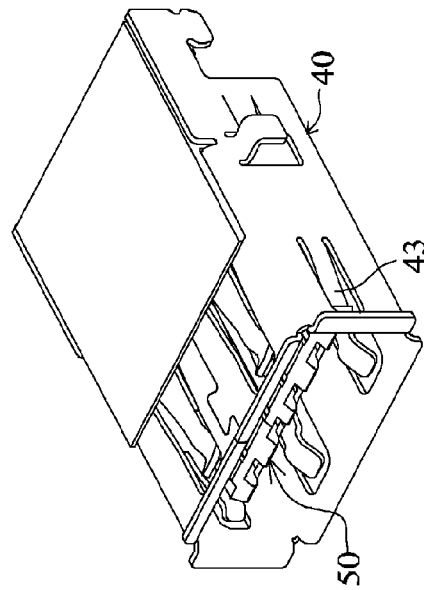

FIG. 51

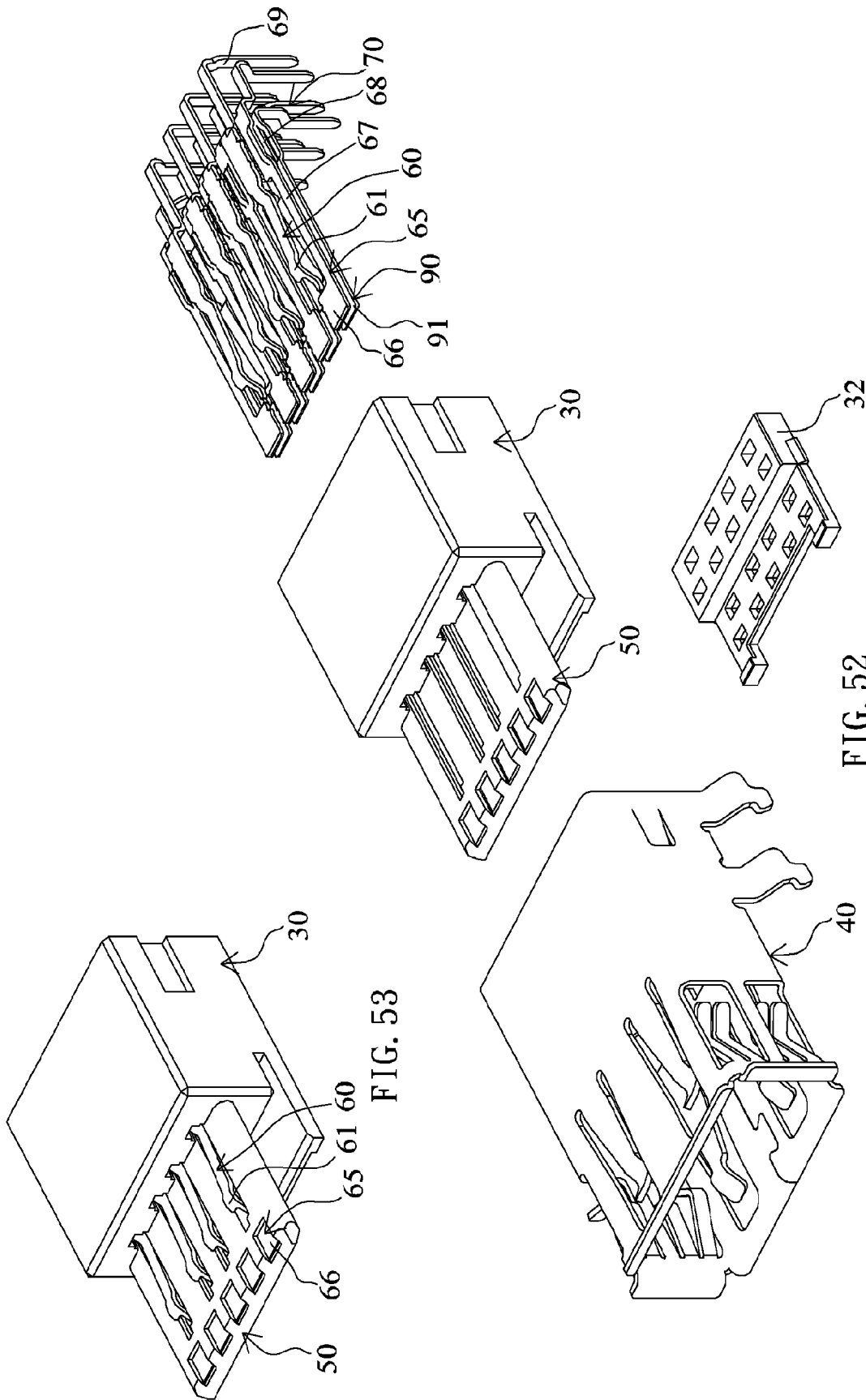

FIG. 53

FIG. 52

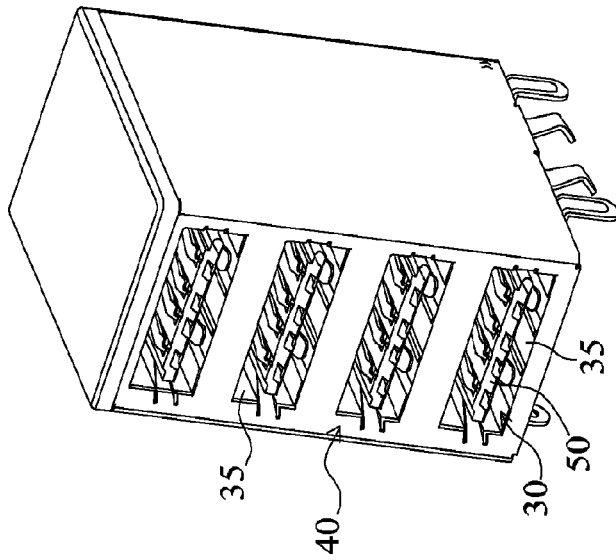

FIG. 54

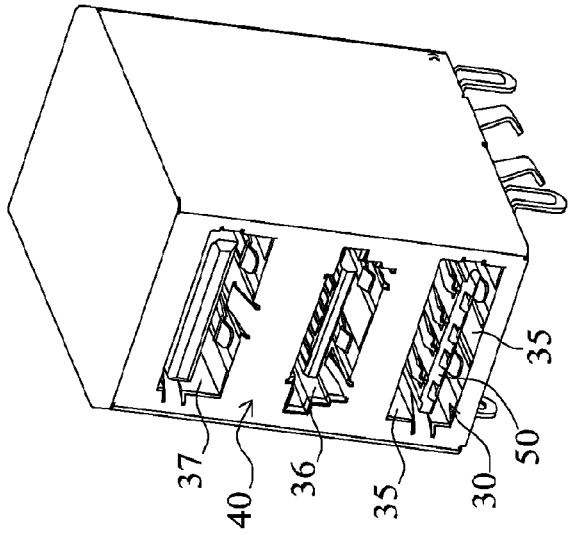

FIG. 56

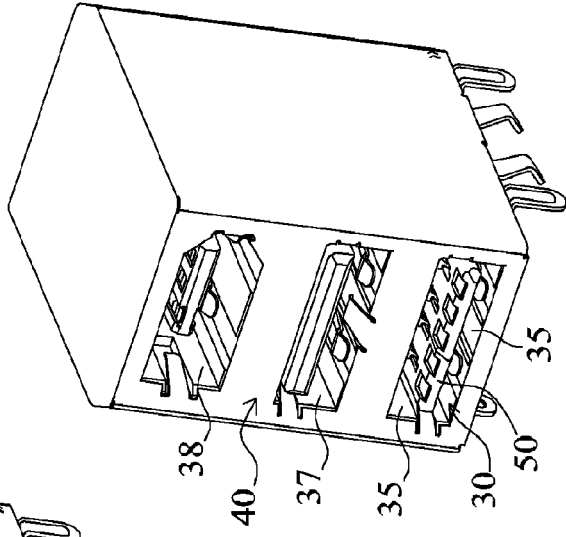

FIG. 57

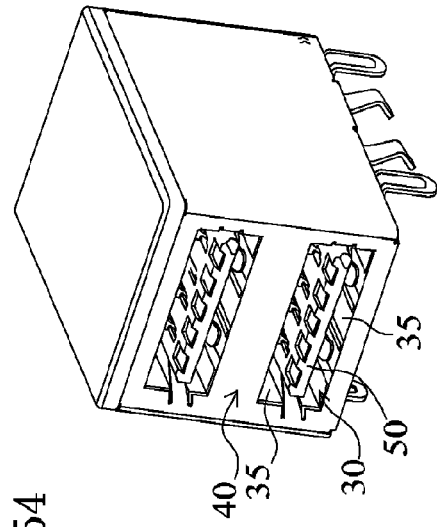

FIG. 55

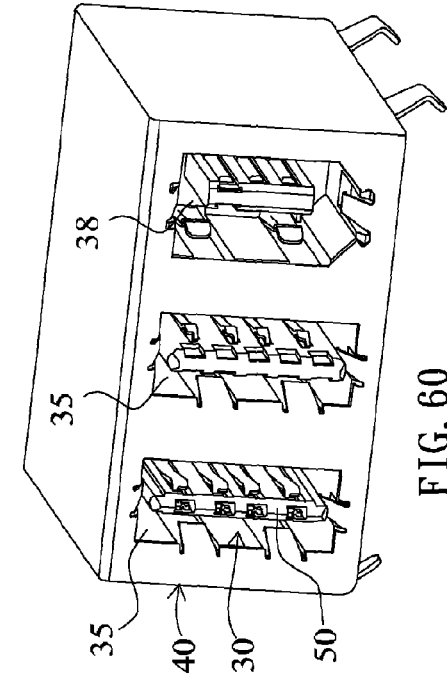

FIG. 60

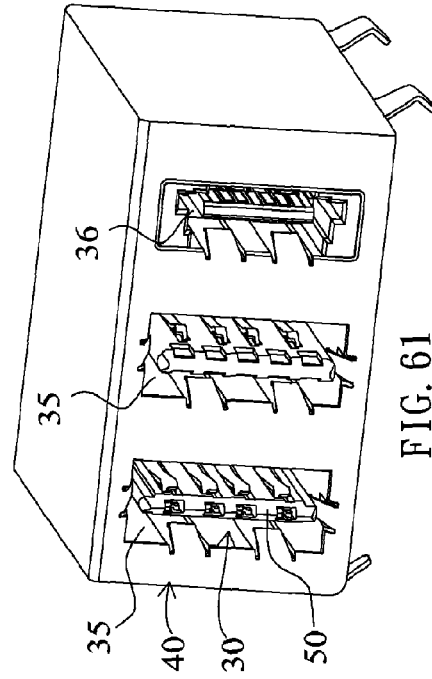

FIG. 61

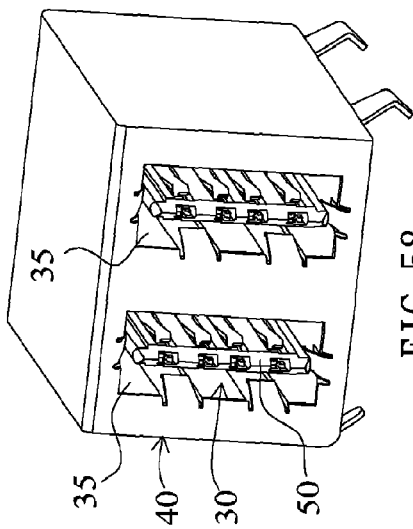

FIG. 58

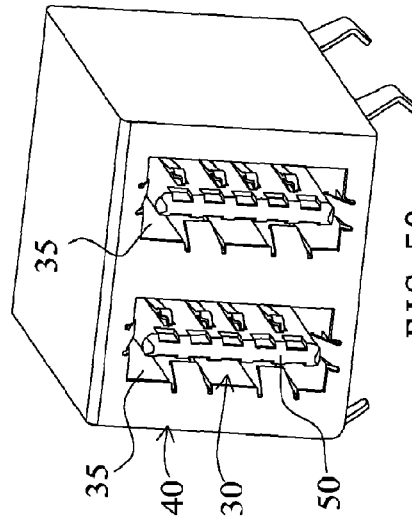
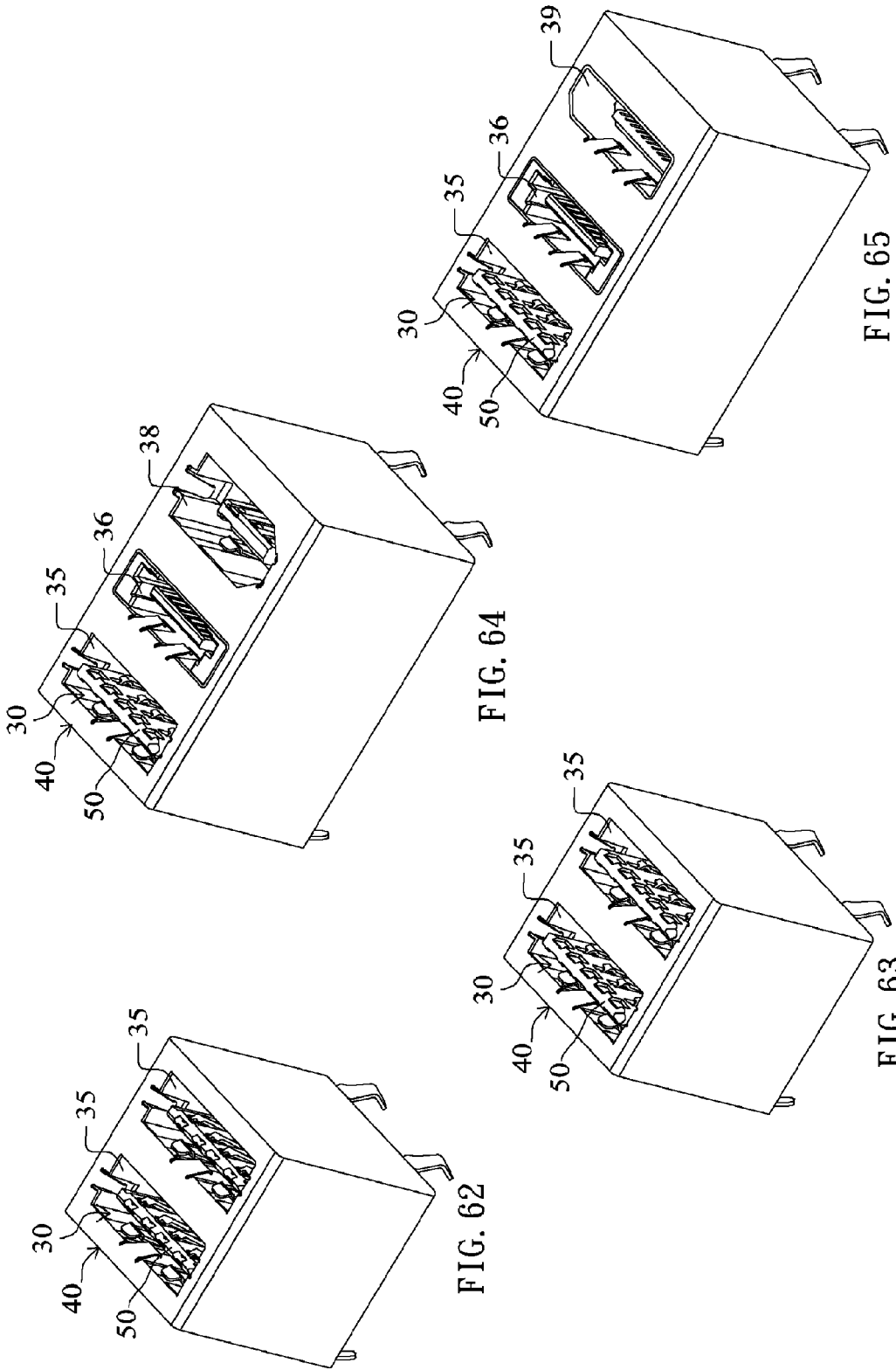

FIG. 59



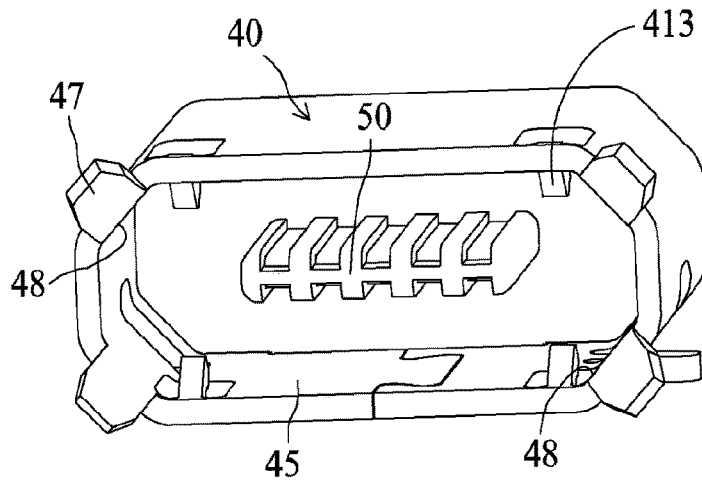

FIG. 66

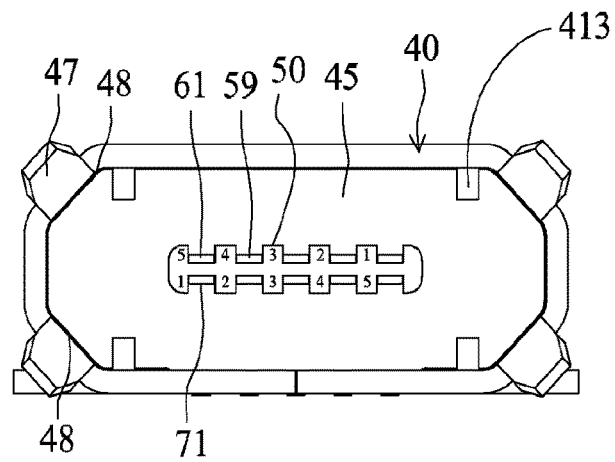

FIG. 67

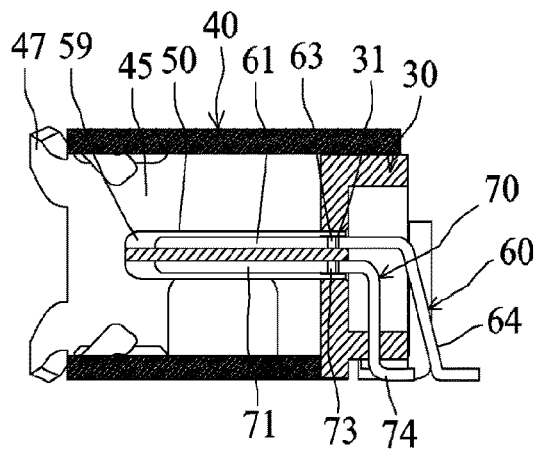

FIG. 68

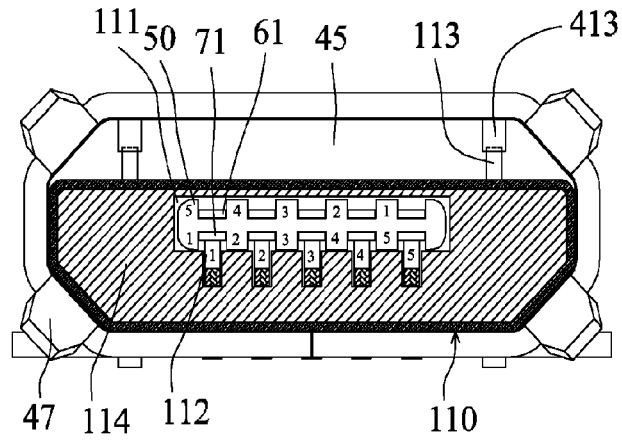

FIG. 69

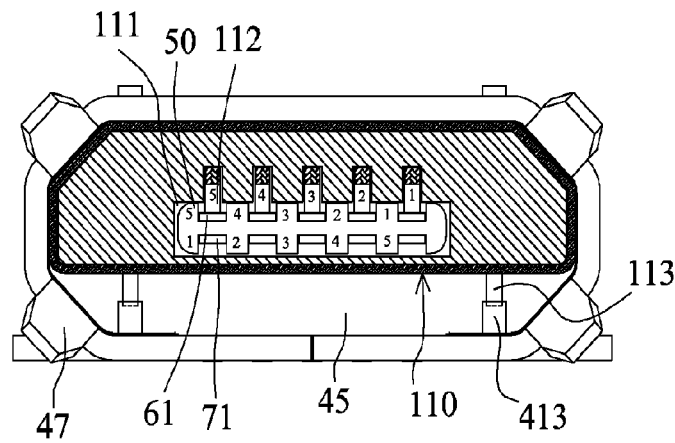

FIG. 70

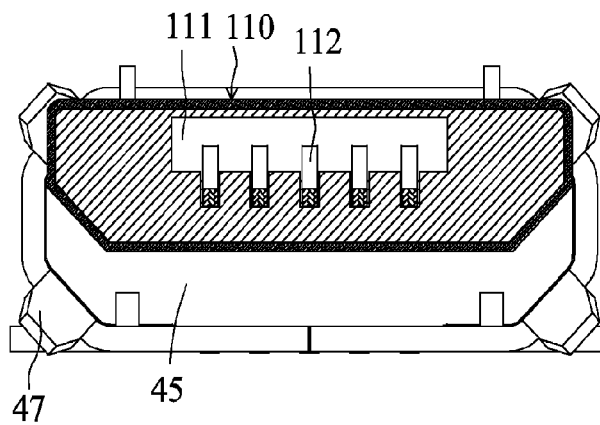

FIG. 71

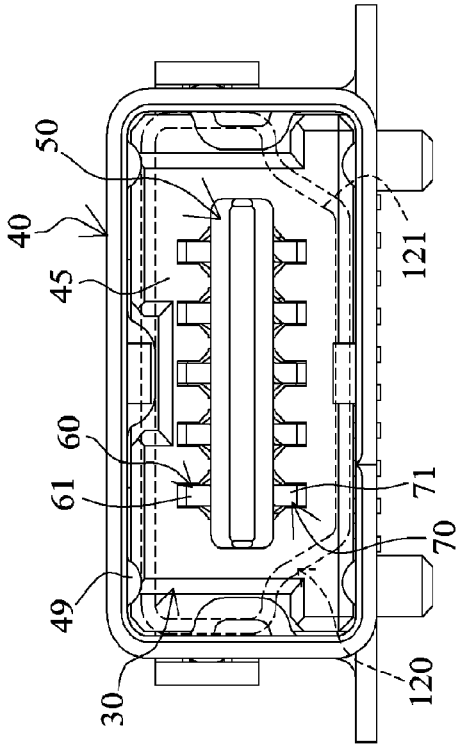

FIG. 74

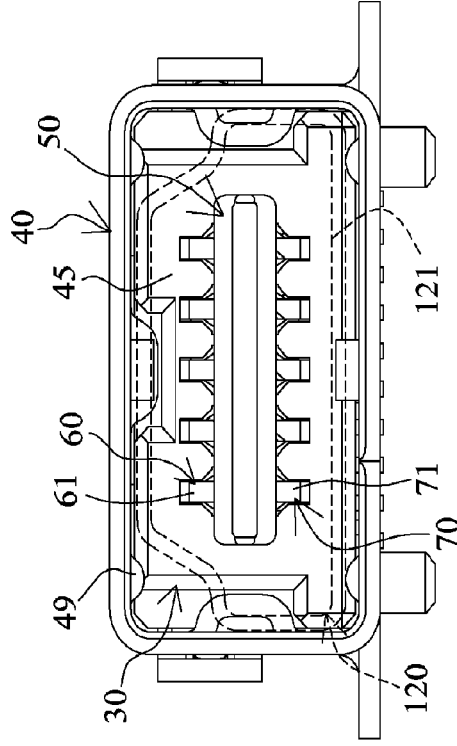

FIG. 75

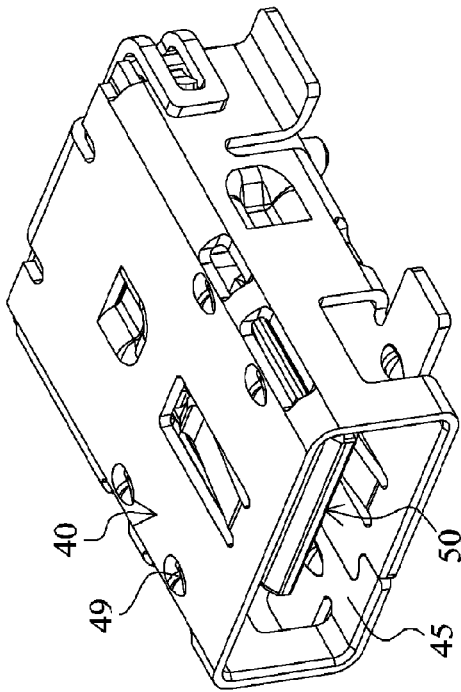

FIG. 72

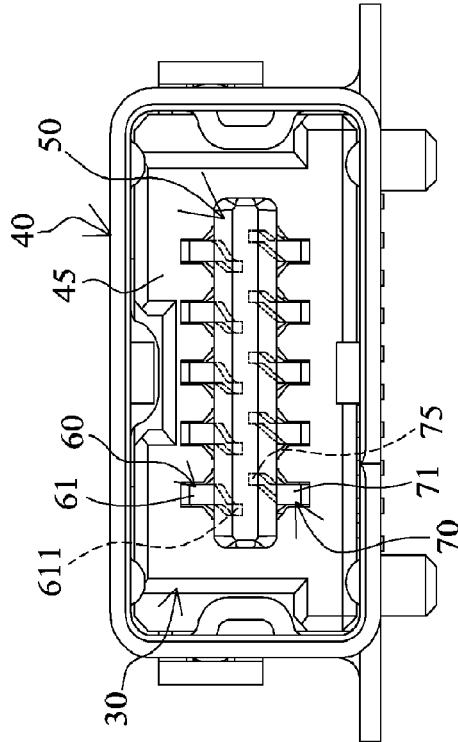

FIG. 73

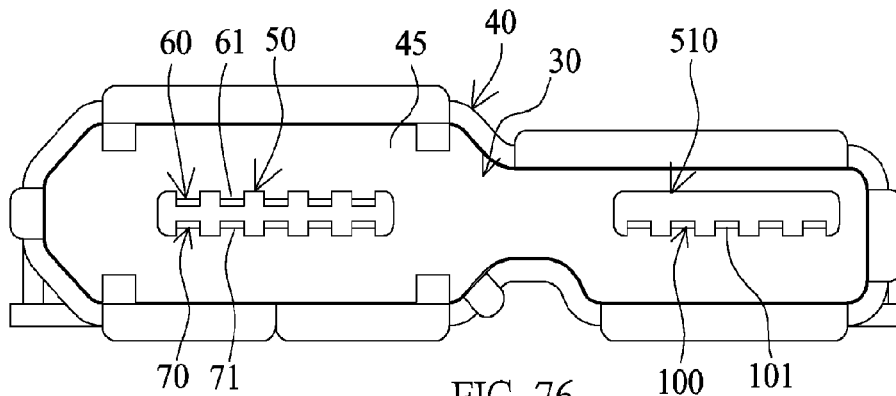

FIG. 76

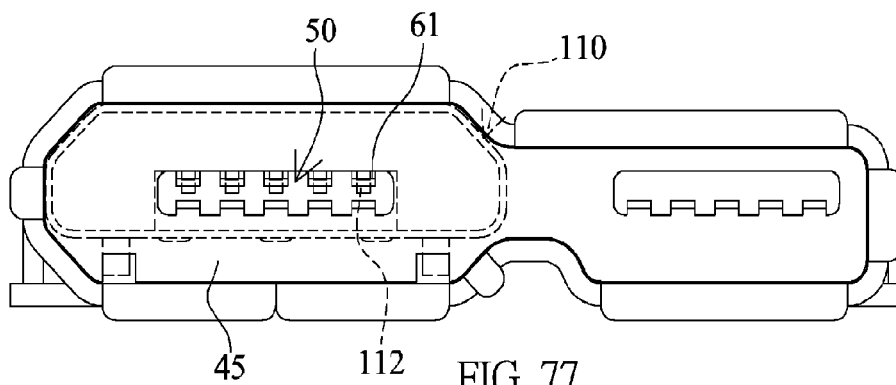

FIG. 77

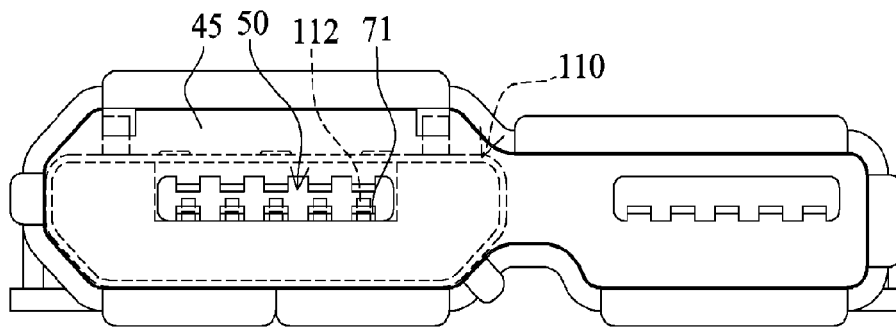

FIG. 78

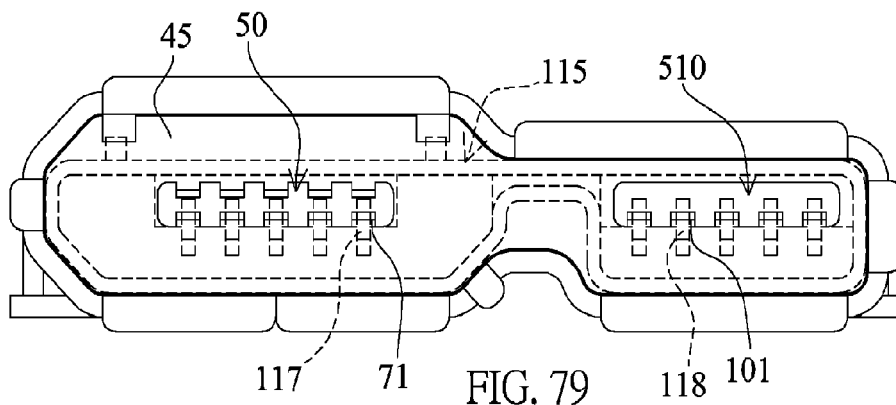

FIG. 79

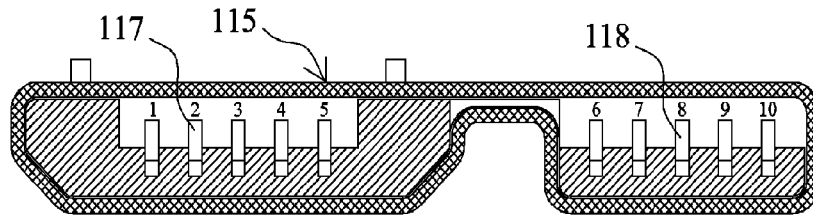

FIG. 80

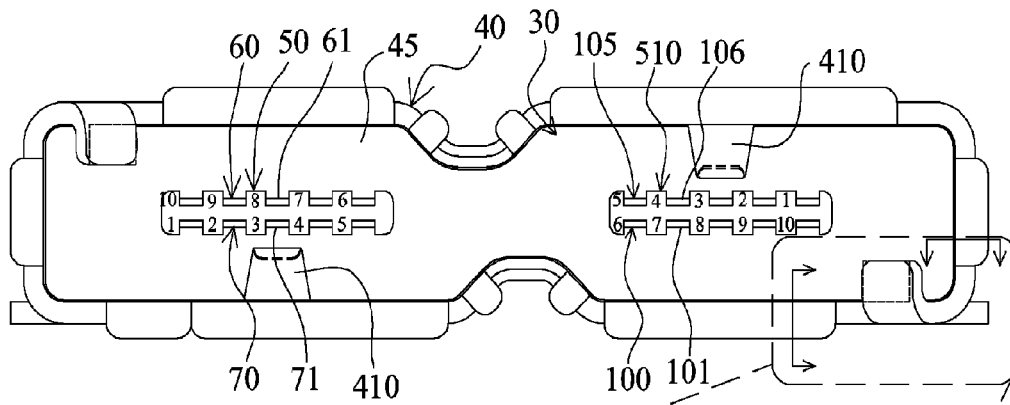

FIG. 81

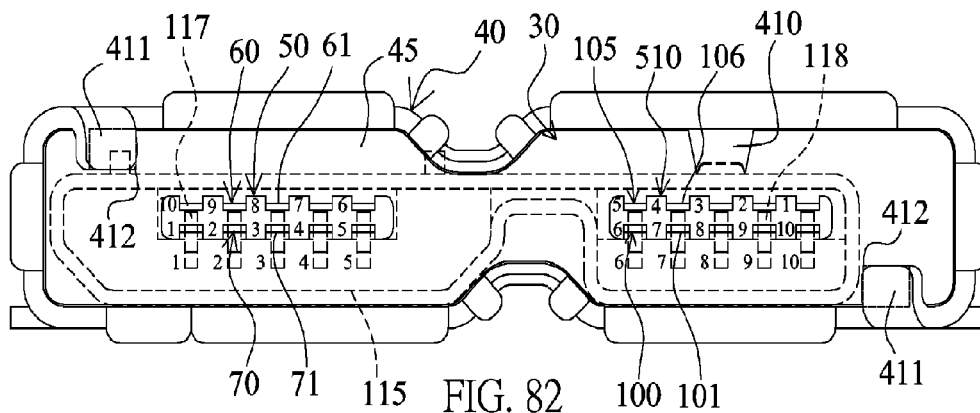
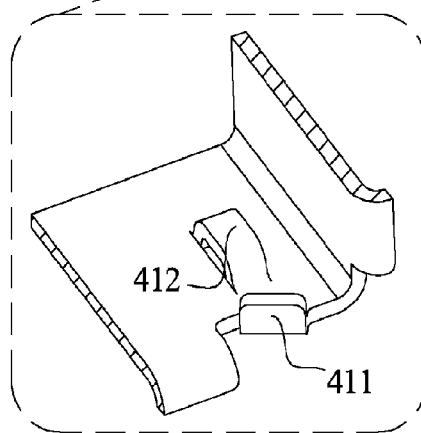
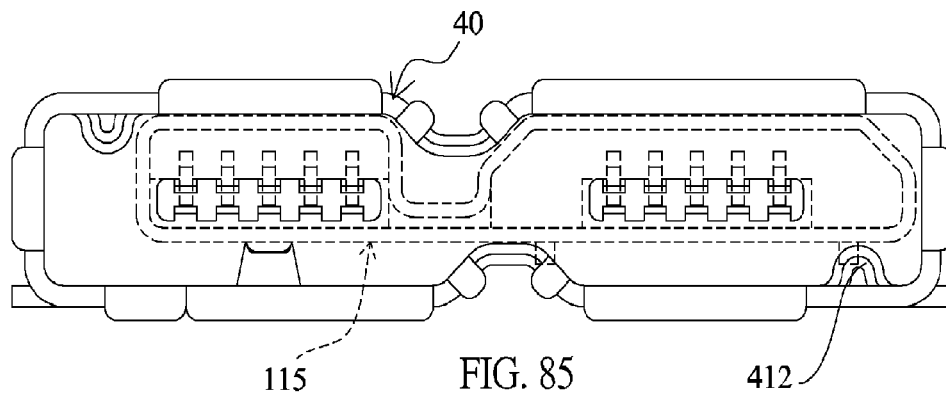
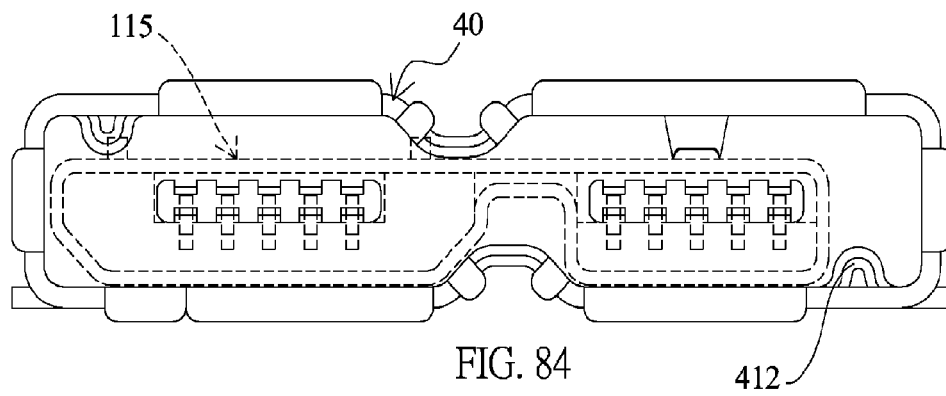
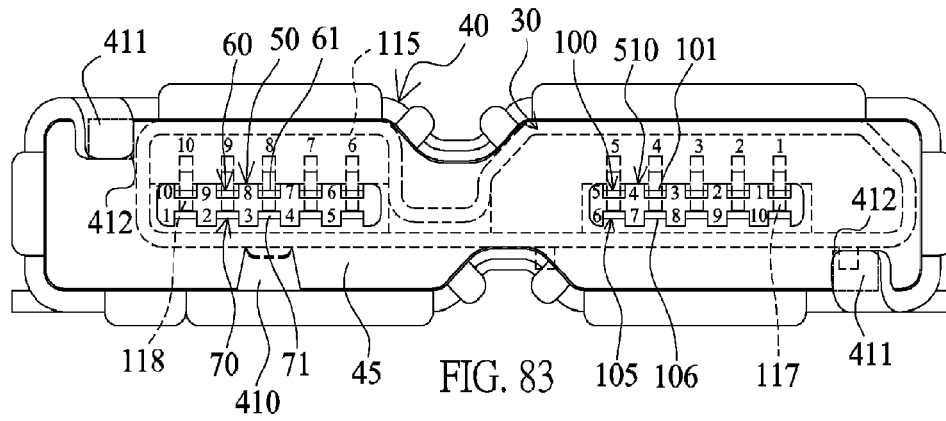

FIG. 82



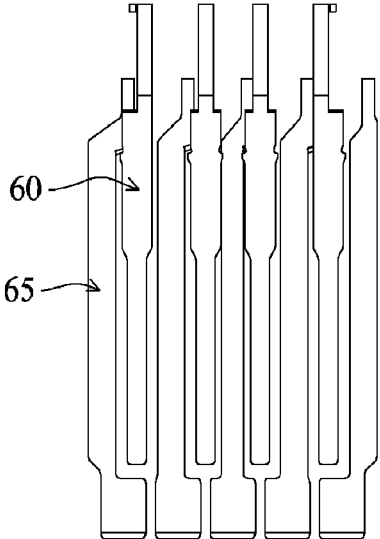

FIG. 86

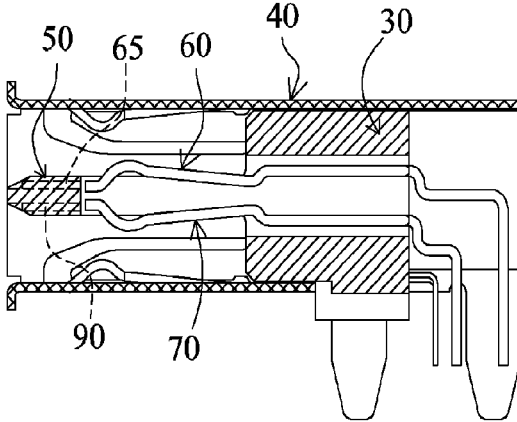

FIG. 87

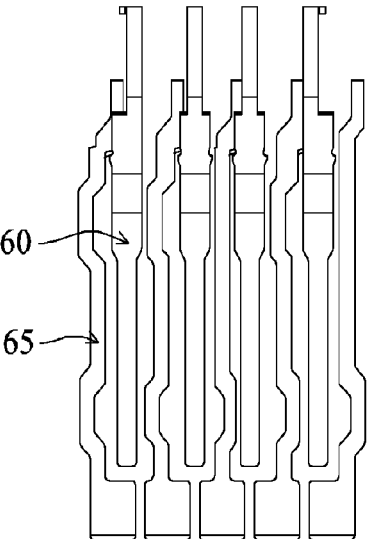

FIG. 88

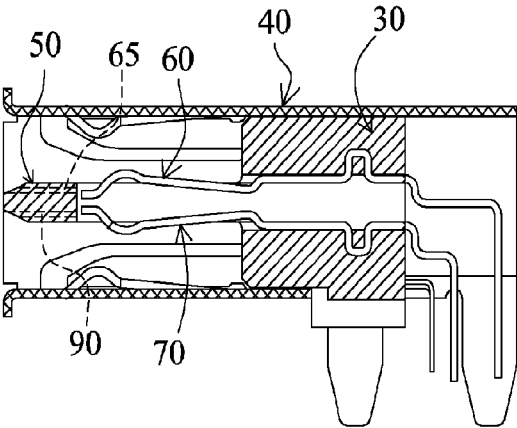

FIG. 89

SOCKET STRUCTURE WITH DUPLEX ELECTRICAL CONNECTION

Matter enclosed in heavy brackets [] appears in the original patent but forms no part of this reissue specification; matter printed in italics indicates the additions made by reissue; a claim printed with strikethrough indicates that the claim was canceled, disclaimed, or held invalid by a prior post-patent action or proceeding.

CROSS-REFERENCE TO RELATED APPLICATIONS

The present application is a Continuation Reissue of U.S. patent application Ser. No. 17/020,359, filed Sep. 14, 2020, now U.S. Pat. No. RE49,287, and the present application is a Reissue of U.S. patent application Ser. No. 12/759,408, filed Apr. 13, 2010, now U.S. Pat. No. 8,198,563. U.S. patent application Ser. No. 17/020,359 is a Reissue of U.S. patent application Ser. No. 12/759,408, filed Apr. 13, 2010, now U.S. Pat. No. 8,198,563, which claims priority to Taiwan Application No. 99100847, filed Jan. 13, 2010, Taiwan Application No. 98210021, filed Jun. 5, 2009, Taiwan Application No. 98117405, filed May 26, 2009, and Taiwan Application No. 98112573, filed Apr. 15, 2009, each of which are incorporated herein by reference in their entirety.

BACKGROUND OF THE INVENTION

1. Field of the Invention

The invention relates to an electrical connector, and more particularly to a socket structure with duplex electrical connection.

2. Related Art

The most popular signal transmission specification of the modern computer apparatus is the universal serial bus (USB). A connector socket and a transmission cable satisfying this specification may make peripheral apparatuses, such as a mouse, a keyboard and the like, which are externally connected to the computer, be immediately detected and used by the computer.

Only one surface of the USB plug has one row of connection terminals. So, one surface of a tongue of the current USB socket has one row of connection terminals. In use, the USB plug has to be correctly inserted so that the connection terminals of the USB plug and the USB socket may be electrically connected together.

In order to ensure the inserted USB plug to be electrically connected to the USB socket, the USB plug and socket have mistake-proof designs. That is, when the USB plug cannot be oppositely inserted, the user has to turn the USB plug and then insert the USB plug so that the electrical connection may be ensured after the insertion.

The user usually randomly inserts the USB plug into the USB socket. So, the possibility of incapable of inserting the USB plug reaches 50%. The user often has to insert the USB plug twice in an inconvenient manner.

Furthermore, the types of the plugs are gradually increased day after day. Also, the USB plugs having the same external shape may have different connection interfaces. If two plugs having the same external shape but different connection interfaces may be inserted into and electrically connected to the same socket, the usage of the socket may be diversified.

SUMMARY OF THE INVENTION

It is therefore an object of the invention to provide a socket structure with duplex electrical connection, wherein

a plug may be normally and oppositely inserted into the socket structure to create electrical connection in a simple and easy way.

Another object of the invention is to provide a socket structure with duplex electrical connection, wherein the socket structure may be used as a dual-slot and may be simultaneously electrically connected to two plugs.

Still another object of the invention is to provide a socket structure with duplex electrical connection, wherein the socket structure may be electrically connected to two plugs, which have the same external shapes but different connection interfaces, in a diversified manner.

Yet still another object of the invention is to provide a socket structure with duplex electrical connection, wherein guide-in sheets of terminals on two surfaces of a tongue are vertically staggered so that the terminals on two surfaces of the tongue may be elastically moved alternately, the larger elastic moving chamber may be obtained and the contact of the terminal has the larger surface contact area.

Yet still another object of the invention is to provide a socket structure with duplex electrical connection, wherein at least one side of a metal housing of the socket structure projects inwardly to form at least one laterally elastically movable elastic sheet, and when a plug is inserted into a connection slot, the at least one elastic sheet may rest against the plug or the tongue to prevent the plug from being turned to break the tongue.

To achieve the above-identified objects, the invention provides a socket structure with duplex electrical connection. The socket structure includes a plastic base; a connection slot, disposed on one end of the base and to be connected to one plug having one row of terminals; a tongue disposed on a front end of the base and within the slot so that chambers of the slot on two sides of the tongue may be normally and oppositely inserted and positioned into the slot; one row of first contacts separately arranged on one surface of the tongue, wherein each first contact is electrically connected to a first pin extending out of the base; and one row of second contacts separately arranged on the other surface of the tongue, wherein each second contact is electrically connected to a second pin extending out of the base. When the plug is inserted into the slot, the row of terminals of the plug are electrically connected to the row of first or second contacts.

A metal housing covering the plastic base may further be provided. At least one side of the metal housing projects inwardly to form at least one laterally elastically movable elastic sheet. When the plug is inserted into the connection slot, the at least one elastic sheet may rest against the plug or the tongue to prevent the plug from turning.

The at least one row of first contacts and the first pins are formed on at least one row of first terminals. The at least one row of second contacts and the second pins are formed on at least one row of second terminals. The first contact and the second contact respectively project beyond one surface of the tongue. The row of first terminals and the row of second terminals pertain to the same connection interface and have oppositely arranged serial numbers. The front end of the first contact has a first guide-in sheet. The front end of the second contact has a second guide-in sheet. The first contact and the second contact are vertically aligned, and the first guide-in sheet and the second guide-in sheet are staggered in a left to right direction.

Further scope of the applicability of the present invention will become apparent from the detailed description given hereinafter. However, it should be understood that the detailed description and specific examples, while indicating

preferred embodiments of the invention, are given by way of illustration only, since various changes and modifications within the spirit and scope of the invention will become apparent to those skilled in the art from this detailed description.

BRIEF DESCRIPTION OF THE DRAWINGS

The present invention will become more fully understood from the detailed description given hereinbelow and the accompanying drawings which are given by way of illustration only, and thus are not limitative of the present invention.

FIG. 1 is a pictorial view showing a first embodiment of the invention.

FIG. 2 is a cross-sectional side view showing the first embodiment of the invention.

FIG. 3 is a cross-sectional top view showing the first embodiment of the invention.

FIG. 4 shows the usage state of the first embodiment of the invention.

FIG. 4A is a front view showing the first embodiment of the invention and the normal state of the USB 2.0 plug.

FIG. 5 shows the usage state of the first embodiment of the invention.

FIG. 5A is a front view showing the first embodiment of the invention and the opposite state of the USB 2.0 plug.

FIG. 6 is a cross-sectional side view showing a second embodiment of the invention.

FIG. 7 is a cross-sectional side view showing a third embodiment of the invention.

FIG. 8 is a cross-sectional side view showing a fourth embodiment of the invention.

FIG. 9 is a cross-sectional top view showing the fourth embodiment of the invention.

FIG. 10 is a cross-sectional side view showing a fifth embodiment of the invention.

FIG. 11 is a cross-sectional top view showing the fifth embodiment of the invention.

FIG. 12 is a front view showing the fifth embodiment of the invention.

FIG. 13 is a cross-sectional side view showing a sixth embodiment of the invention.

FIG. 14 is a cross-sectional top view showing the sixth embodiment of the invention.

FIG. 15 is a cross-sectional bottom view showing the sixth embodiment of the invention.

FIGS. 16 and 17 show the usage states of the sixth embodiment of the invention.

FIG. 18 is a pictorial view showing a light and handy mobile disk.

FIG. 19 shows the usage state of the sixth embodiment of the invention.

FIG. 20 is a side view showing another light and handy mobile disk.

FIG. 21 shows the usage state of the sixth embodiment of the invention.

FIG. 22 is a cross-sectional side view showing a seventh embodiment of the invention.

FIG. 23 is a pictorial view showing an eighth embodiment of the invention.

FIG. 24 is a cross-sectional side view showing a ninth embodiment of the invention.

FIG. 25 is a front view showing the ninth embodiment of the invention.

FIG. 26 is a cross-sectional bottom view showing the ninth embodiment of the invention.

FIG. 27 is a cross-sectional top view showing the ninth embodiment of the invention.

FIGS. 28 and 29 show the usage states of the ninth embodiment of the invention.

FIG. 30 is a cross-sectional side view showing a tenth embodiment of the invention.

FIG. 31 is a cross-sectional top view showing the tenth embodiment of the invention.

FIG. 32 is a cross-sectional bottom view showing the tenth embodiment of the invention.

FIG. 33 is a cross-sectional front view showing an eleventh embodiment of the invention.

FIG. 34 is a cross-sectional side view showing the eleventh embodiment of the invention.

FIG. 35 is a pictorially exploded view showing a twelfth embodiment of the invention.

FIG. 36 is a pictorially assembled view showing the twelfth embodiment of the invention.

FIG. 37 is a front view showing the twelfth embodiment of the invention.

FIGS. 38 to 41 are pictorial views showing the usage states of the twelfth embodiment of the invention.

FIG. 42 is a pictorially assembled view showing a thirteenth embodiment of the invention.

FIGS. 43 and 44 are pictorial views showing the usage states of the thirteenth embodiment of the invention.

FIG. 45 is a pictorially assembled view showing a fourteenth embodiment of the invention.

FIGS. 46 and 47 are pictorial views showing the usage states of the fourteenth embodiment of the invention.

FIG. 48 is a pictorially assembled view showing a fifteenth embodiment of the invention.

FIG. 49 is a pictorially assembled view showing a sixteenth embodiment of the invention.

FIG. 50 is a pictorially assembled view showing a seventeenth embodiment of the invention.

FIG. 51 is a pictorially assembled view showing an eighteenth embodiment of the invention.

FIG. 52 is a pictorially exploded view showing a nineteenth embodiment of the invention.

FIG. 53 is a pictorially assembled view showing terminals and a plastic base of the nineteenth embodiment of the invention.

FIG. 54 is a pictorially assembled view showing a 20th embodiment of the invention.

FIG. 55 is a pictorially assembled view showing a 21st embodiment of the invention.

FIG. 56 is a pictorially assembled view showing a 22nd embodiment of the invention.

FIG. 57 is a pictorially assembled view showing a 23rd embodiment of the invention.

FIG. 58 is a pictorially assembled view showing a 24th embodiment of the invention.

FIG. 59 is a pictorially assembled view showing a 25th embodiment of the invention.

FIG. 60 is a pictorially assembled view showing a 26th embodiment of the invention.

FIG. 61 is a pictorially assembled view showing a 27th embodiment of the invention.

FIG. 62 is a pictorially assembled view showing a 28th embodiment of the invention.

FIG. 63 is a pictorially assembled view showing a 29th embodiment of the invention.

FIG. 64 is a pictorially assembled view showing a 30th embodiment of the invention.

FIG. 65 is a pictorially assembled view showing a 31st embodiment of the invention.

5

FIG. 66 is a pictorially assembled view showing a 32nd embodiment of the invention.

FIG. 67 is a front view showing the 32nd embodiment of the invention.

FIG. 68 is a cross-sectional side view showing the 32nd embodiment of the invention.

FIGS. 69 to 71 show the usage states of the 32nd embodiment of the invention.

FIG. 72 is a pictorially assembled view showing a 33rd embodiment of the invention.

FIG. 73 is a front view showing the 33rd embodiment of the invention.

FIGS. 74 and 75 show the usage states of the 33rd embodiment of the invention.

FIG. 76 is a front view showing a 34th embodiment of the invention.

FIGS. 77 to 79 show the usage states of the 34th embodiment of the invention.

FIG. 80 is a cross-sectional view showing a micro USB 3.0 plug.

FIG. 81 is a front view showing a 35th embodiment of the invention.

FIGS. 82 and 83 show the usage states of the 35th embodiment of the invention.

FIGS. 84 and 85 show the usage states of a 36th embodiment of the invention.

FIG. 86 is a schematic top view showing terminals when the high frequency of the invention is increased.

FIG. 87 is a schematic side view showing the terminals when the high frequency of the invention is increased.

FIG. 88 is a schematic top view showing terminals when the high frequency of the invention is decreased.

FIG. 89 is a schematic side view showing the terminals when the high frequency of the invention is decreased.

DETAILED DESCRIPTION OF THE INVENTION

The present invention will be apparent from the following detailed description, which proceeds with reference to the accompanying drawings, wherein the same references relate to the same elements.

Referring to FIGS. 1 to 3, a USB 2.0 socket of this embodiment includes a plastic base 30, a metal housing 40, a tongue 50, one row of first terminals 60 and one row of second terminals 70.

The plastic base 30 has one row of terminal slots 31, and a rear cover 32 covers a rear end of the plastic base 30 from bottom to top.

The metal housing 40 covers the plastic base 30. A front section of the metal housing is formed with a connection slot 45, which may be electrically connected to a USB 2.0 plug.

The tongue 50 and the plastic base 30 are integrally injection molded together. The tongue 50 has a first surface 501 and a second surface 502 disposed opposite the first surface 501, and is horizontally disposed on the front end of the plastic base 30 and at a middle of the connection slot 45, such that the connection slot 45 is formed with compatible and symmetrical profiles on top and bottom sides of the tongue 50 and compatible and symmetrical profiles on left and right sides of the tongue 50. Thus, the USB 2.0 plug is normally and oppositely inserted and positioned into the connection slot 45 to create the bidirectional insertion and connection, and the tongue 50 has four through slots 51 separately arranged.

One row of four first terminals 60 are separately arranged and fixed to the plastic base 30. The first terminal is

6

integrally formed with a first contact 61, a first extension 62, a first fixing portion 63 and a first pin 64. The first fixing portion 63 is fixed to the terminal slot 31 of the plastic base 30. The first contact 61, arranged on the first surface 501 of the tongue 50, projects beyond the top of the tongue 50 and is elastically moved in correspondence with the through slot 51. The first pin 64 extends out of the plastic base 30.

The one row of second terminals 70 and the one row of first terminals 60 pertain to the same connection interface and the terminals have oppositely arranged serial numbers. Also, there are four second terminals 70 separately arranged and fixed to the plastic base 30. The second terminal is integrally formed with a second contact 71, a second extension 72, a second fixing portion 73 and a second pin 74. The second fixing portion 73 is fixed to the terminal slot 31 of the plastic base 30. The second contact 71, arranged on the second surface 502 of the tongue 50, projects beyond the bottom of the tongue 50 and is elastically moved in correspondence with the through slot 51. The second pin 74 extends out of the plastic base 30. The first contact 61 of the first terminal 60 and the second contact 71 of the second terminal 70 corresponding to the same through slot 51 are aligned with each other in a front to rear direction.

The one row of second terminals 70 and the one row of first terminals 60 have oppositely arranged serial numbers. As shown in FIG. 4A, the second terminals 70 on the bottom of the tongue have the serial numbers of 1, 2, 3, 4 from left to right, while the first terminals 60 on the top of the tongue have the serial numbers of 4, 3, 2, 1 from left to right. Thus, the same signal sorting may be obtained when the USB 2.0 plug is normally and oppositely electrically connected thereto.

The one row of first terminals 60 and the one row of second terminals 70 are formed by pressing the same metal sheet. So, the first fixing portion 63 and the second fixing portion 73 are located on the same level so that the two rows may be assembled with and fixed to the terminal slots 31 of the plastic base 30 at a time. In addition, the first pin 64 and the second pin 74 are aligned in one row.

According to the above-mentioned structure, FIGS. 4 and 4A show the usage states of the USB 2.0 plug of a signal line. FIG. 4A is a front view showing the socket of the invention and the plug 10 in a normal state. The USB 2.0 plug 10 has a plastic base 12 and a metal housing 13 covering the plastic base 12. A chamber 14 is formed between the metal housing 13 and the plastic base 12. One surface of the plastic base 12 is formed with one row of connection terminals 11. In a front view, the one row of connection terminals 11 have the serial numbers of 4, 3, 2, 1 from left to right (*i.e.*, a functional reverse mirror configuration). When the connection terminals 11 of the USB 2.0 plug 10 face the second surface 502 of the tongue 50 and are normally inserted into the connection slot 45, its chamber 14 is fitted with the tongue 50, and its one row of connection terminals 11 are turned into the serial numbers of 1, 2, 3, 4 from left to right, and are electrically connected to the second contact 71 of the one row of second terminals 70 on the bottom of the tongue 50 (the serial numbers are 1, 2, 3, 4 from left to right). As shown in FIGS. 5 and 5A, when the connection terminals 11 of the USB 2.0 plug 10 face the first surface 501 of the tongue 50 and are oppositely inserted into the connection slot 45, its chamber 14 is also fitted with the tongue 50, and its one row of connection terminals 11 are turned into the serial numbers of 4, 3, 2, 1 from left to right and are electrically connected to the first contacts 61 of the one row of first terminals 60 on the top of the tongue 50 (the serial numbers are 4, 3, 2, 1 from left to right). Because the

tongue **50** is horizontally disposed at the middle of the connection slot **45**, the profile of the connection slot **45** above the tongue **50** is symmetrical with the profile thereof below the tongue, and the profiles of the connection slot **45** on the left and right sides of the tongue are symmetrical with each other. Thus, the USB 2.0 plug **10** may be normally and oppositely inserted and positioned into the connection slot **45**.

According to the above-mentioned description, it is obtained that the invention may be electrically connected to the USB 2.0 plug, which is normally and oppositely inserted, so that the convenience in use may be obtained.

As shown in FIG. 6, the second embodiment of the invention is almost the same as the first embodiment except that the plastic base **30** of this embodiment has two rows of terminal slots **31**, and the one row of first terminals **60** and the one row of second terminals **70** are formed by respectively pressing two metal sheets. So, the first fixing portion **63** is engaged with the upper terminal slot **31** of the plastic base **30**, and the second fixing portion **73** is engaged with the lower terminal slot **31** of the plastic base **30**.

As shown in FIG. 7, the third embodiment of the invention is almost the same as the second embodiment except that the first pins **64** of the one row of first terminals **60** and the first pins **74** of the one row of second terminals **70** of this embodiment are staggered and respectively arranged in two rows.

As shown in FIGS. 8 and 9, the fourth embodiment of the invention is almost the same as the first embodiment except that the first contact **61** of the first terminal **60** and the second contact **71** of the second terminal **70** of this embodiment are parallel to each other in a left to right direction.

As shown in FIGS. 10 to 12, the fifth embodiment of the invention is almost the same as the first embodiment except that the tongue **50** of this embodiment needs not to be formed with the through slot. The first contact **61** of the first terminal **60** is formed by prodding the plate surface of the first extension **62** and projects beyond the plate surface. The one end of the first contact **61** is connected to the first extension **62** and gradually protrudes to the other end from front to rear and is opened. The plate surface of the first extension **62** has an opening **620**. When the first contact **61** is pressed and flattened, the first contact **61** may lie on the opening **620**. The one row of second terminals **70** and the one row of first terminals **60** have the same structure, pertain to the same connection interface and have oppositely arranged serial numbers. The second contact **71** of the second terminal **70** is formed by prodding the plate surface of the second extension **72** and projects beyond the plate surface. The one end of the second contact **71** is connected to the second extension **72**, and gradually protrudes to the other end from front to rear and is opened. The first contact **61** and the second contact **71** are vertically aligned with each other.

As shown in FIGS. 13 to 15, the sixth embodiment of the invention is a USB 3.0 socket, which is substantially the same as the third embodiment except that this embodiment further has one row of first contacts **53** disposed in front of the first contacts **61**, and one row of second contacts **57** disposed in front of the second contact **71** in addition to one row of first contacts **61** and one row of second contacts **71**. That is, the tongue **50** is a circuit board assembled and positioned in the plastic base **30**. Five first traces **52** are disposed on the top surface of the tongue **50**, and have first contacts **53** separately arranged on the front section of the tongue and first connection terminals **54** disposed on the rear section of the tongue. The row of first connection terminals

54 are electrically connected to an additional row of first pins **80**. Five second traces **56** are disposed on a bottom surface of the tongue **50**, and have second contacts **57** separately arranged on the front section of the tongue and second connection terminals **58** disposed on the rear section of the tongue. The row of second connection terminals **58** are electrically connected to an additional row of second pins **85**.

The one row of first contacts **53** and the one row of second contacts **57** pertain to the same connection interface and have oppositely arranged serial numbers.

The one row of first pins **80** are bonded to the one row of first connection terminals **54**. The one row of second pins **85** are bonded to the one row of second connection terminals **58**. In addition, the first fixing portion **63** of the one row of first terminals **60** is bonded and fixed to the top surface of the tongue **50**. First fixing portions **73** of the one row of second terminals **70** are bonded and fixed to the bottom surface of the tongue **50**. The one row of first pins **80** and the first pins **64** of the one row of first terminals **60** are arranged in a row. The one row of second pins **85** and the second pins **74** of the one row of second terminals **70** are arranged in a row.

According to the above-mentioned structure, as shown in FIG. 16, when the USB 3.0 plug **15** is normally inserted, its one row of connection terminals **16** are electrically connected to the second contacts **71** of the second terminals **70**. The other row of connection terminals **17** are electrically connected to the second contacts **57** of the second traces. As shown in FIG. 17, when the USB 3.0 plug **15** is oppositely inserted, its one row of connection terminals **16** are electrically connected to the first contacts **61** of the first terminals **60**, and the other one row of connection terminals **17** are electrically connected to the first contacts **53** of the first traces.

FIG. 18 is a pictorial view showing a light and handy mobile disk **20**. One end of the disk **20** has a plug **21**, which is a USB 2.0 plug without a metal housing. One surface of the plug **21** has four connection terminals **22**, which are separately arranged and cannot be elastically moved.

FIG. 19 shows the usage state of the light and handy mobile disk **20**. When the plug **21** is connected to the top of the tongue **50**, the one row of connection terminals **22** are electrically connected to the first contacts **61** of the one row of first terminals **60** on the top of the tongue. When the plug **21** is connected to the bottom of the tongue **50**, the one row of connection terminals **22** are electrically connected to the second contacts **71** of the one row of second terminals **70** on the bottom of the tongue. According to the above-mentioned description, it is obtained that the socket structure of the invention, when being connected to the light and handy mobile disk, may serve as a dual-slot so that two light and handy mobile disks may be simultaneously connected thereto.

FIG. 20 is a side view showing another light and handy mobile disk **25**. One end of the disk **25** has a plug **28**, which is a USB 3.0 plug without a metal housing. The plug **28** is substantially the same as the plug **20**. One surface of the plug **28** is formed with one row of four connection terminals **26**, which are separately arranged and cannot be elastically moved, and further formed with one row of five connection terminals **27**, which are separately arranged and may be moved elastically.

FIG. 21 shows the usage state of the light and handy mobile disk **25**. When the plug **28** is electrically connected to the top surface of the tongue **50**, the one row of connection terminals **26** are electrically connected to the first contacts **61** of the one row of first terminals **60** on the top of

the tongue. The one row of connection terminals 27 are electrically connected to the first contacts 53 of one row of first traces on the top surface of the tongue. When the plug 28 is electrically connected to the bottom of the tongue 50, the one row of connection terminals 26 are electrically connected to the first contacts 71 of the one row of second terminals 70 on the bottom of the tongue. The one row of connection terminals 27 are electrically connected to the second contacts 57 of one row of second traces on the bottom surface of the tongue, so that two light and handy mobile disks 25 may be simultaneously connected to the top and bottom sides of the tongue 50.

As shown in FIG. 22, the seventh embodiment of the invention is almost the same as the sixth embodiment except that the one row of first pins 80 are not aligned with the first pins 64 of the one row of first terminals 60 in this embodiment, and the one row of second pins 85 are not aligned with the second pins 74 of the one row of second terminals 70.

As shown in FIG. 23, the eighth embodiment of the invention is almost the same as the first embodiment except that this embodiment pertains to a multilayer USB 2.0 socket, and the plastic base 30 has two connection slots 35 stacked together.

As shown in FIGS. 24 to 27, the ninth embodiment of the invention is almost the same as the fifth embodiment, and its tongue 50 is also disposed at the middle of the connection slot 45, so that the chamber above the tongue 50 of the connection slot 45 is the same as the chamber below the tongue 50, and the chambers on the left and right sides of the tongue are the same. The difference between the ninth and fifth embodiments is that the one row of first terminals 60 on the top surface of the tongue 50 and the one row of second terminals 70 on the bottom surface of the tongue 50 pertain to different connection interfaces in this embodiment. The one row of four second terminals 70 are separately arranged on the bottom surface of the tongue 50. The second terminals 70 of the ninth and fifth embodiments have the same structure. The second terminal 70 is also integrally formed with a second contact 71, a second extension 72, a second fixing portion 73 and a second pin 74. The one row of nine first terminals 60 are separately arranged on the top surface of the tongue 50. The structure of the first terminal 60 is almost the same as that of the second terminal 70, and is also integrally formed with a first contact 61, a first extension 62, a first fixing portion 63 and a first pin 64.

FIG. 28 shows the usage state of the USB 2.0 plug 10 of the signal line. When the connection terminal 11 of the USB 2.0 plug 10 is inserted upwardly into the connection slot 45, its chamber 14 is fitted with the tongue 50, and its one row of connection terminals 11 are electrically connected to the second contacts 71 of the second terminals 70 on the bottom of the tongue 50. FIG. 29 shows the usage state of the plug 18 having the shape the same as that of the USB 2.0 plug but a connection interface different from that of the USB 2.0 plug. The plug 18 has one row of nine connection terminals 19. When the connection terminal 19 of the plug 18 is inserted downwardly into the connection slot 45, its one row of connection terminals 19 are electrically connected to the first contacts 61 of the first terminals 60 on the top of the tongue 50.

According to the above-mentioned description, it is obtained that the socket structure of this embodiment may be electrically connected to two plugs having metal housings and the same shape but different connection interfaces so that the usage thereof may be diversified.

Of course, the socket structure of this embodiment may also be connected to two light and handy mobile disks or storage cards having two different connection interfaces but having no metal housing.

As shown in FIGS. 30 to 32, the tenth embodiment of the invention is a USB 3.0 socket, which is almost the same as the fifth embodiment except for the difference to be described in the following. This embodiment also has one row of first terminals 60 and one row of second terminals 70, which have the same connection interface and have oppositely arranged serial numbers. This embodiment further has one row of first terminals 65 and one row of second terminals 90, which have the same connection interface and have oppositely arranged serial numbers.

The first terminal 65 has a first contact 66, a first extension 67, a first fixing portion 68 and a first pin 69. The one row of five first terminals 65 are disposed on the top surface of the tongue 50 and are arranged between the one row of first terminals 60. The first contacts 66 of the first terminals 65, which cannot be elastically moved, lie on the top surface of the tongue. The first contact 66 of the first terminal 65 is disposed in front of the first contact 61 of the first terminal 60.

The second terminal 90 has a second contact 91, a second extension 92, a second fixing portion 93 and a second pin 94. The one row of five second terminals 90 are disposed on the bottom surface of the tongue 50 and arranged between the one row of second terminals 70. The second contact 91 of the second terminal 90 cannot be elastically moved and lies on the top surface of the tongue. The second contact 91 of the second terminal 90 is disposed in front of the second contact 71 of the second terminal 70.

The two rows of first terminals 60 and 65 are formed by pressing the same metal sheet. The two rows of second terminals 70 and 90 are formed by pressing the same metal sheet.

As shown in FIGS. 33 and 34, the eleventh embodiment of the invention is a mini USB 2.0 socket, which may allow a plug to be normally and oppositely inserted for connection. Compare with the connection interface of USB 2.0, the connection interface of the mini USB 2.0 has an additional terminal. So, the structure of this embodiment is substantially the same as the first embodiment, and similarly has a plastic base 30, a metal housing 40, a tongue 50, one row of first terminals 60 and one row of second terminals 70. The difference therebetween is that there are one row of five first terminals 60 in this embodiment, and the first terminal 60 has a first contact 61 projecting beyond the top surface of the tongue 50. There are also one row of five second terminals 70. Each second terminal has a second contact 71 projecting beyond the bottom surface of the tongue 50. The one row of second terminals 70 and the one row of first terminals 60 pertain to the same connection interface and have oppositely arranged serial numbers. The structures of the second terminal 70 and the first terminal 60 are also substantially the same as those of the first embodiment.

As shown in FIGS. 35 to 37, the twelfth embodiment of the invention is a USB 2.0 socket, which allows a plug to be normally and oppositely inserted for connection and is almost the same as the first embodiment. The socket similarly has a plastic base 30, a metal housing 40, a tongue 50, one row of first terminals 60 and one row of second terminals 70. The differences between the twelfth and first embodiments are described in the following.

Two sides of the metal housing 40 are prodded inwardly to form four laterally elastically movable elastic sheets, which include two outer elastic sheets 41 and two inner

11

elastic sheets **42** respectively disposed above and below the tongue **50**. The two inner elastic sheets **42** are disposed on inner sides of the two outer elastic sheets **41**. The two inner elastic sheets **42** respectively rest against the top and bottom surfaces on one side of the tongue **50**. Each elastic sheet has one end connected to a portion near the front end on the two sides of the metal housing **40** and extends inwardly in an arced manner. Each elastic sheet has a projection **46**. When the projection **46** is pressed, the elastic sheet is elastically moved outwardly.

The front end of the first contact **61** of the first terminal **60** has a first guide-in sheet **611**. The plate surface of the first guide-in sheet **611** is smaller than the plate surface of the first contact **61**. The front end of the second contact **71** of the second terminal **70** has a second guide-in sheet **75**. The plate surface of the second guide-in sheet **75** is smaller than the plate surface of the second contact **71**. The first contact **61** and the second contact **71** are vertically aligned, and the first guide-in sheet **611** and the second guide-in sheet **75** are staggered in a left to right direction. Both the first guide-in sheet **611** and the second guide-in sheet **75** are hooked on the tongue **50**.

As shown in FIG. **39**, when the connection terminal **22** of the light and handy mobile disk **20** is inserted downwardly into the space above the tongue **50**, two elastic sheets on two sides of the top of the tongue **50** are pushed away and elastically moved outwardly, and the inner elastic sheets **42** on two sides of the bottom of the tongue rest against the bottom surface of the tongue **50**. So, when the light and handy mobile disk **20** is improperly inserted to turn downwards, the inner elastic sheets **42** resting against the bottom surface of the tongue **50** can prevent the tongue **50** from being forced downwards and thus broken.

When the first contact **61** of the first terminal **60** is in elastic contact with the connection terminal **22** of the light and handy mobile disk **20** and is elastically moved downwards, the first guide-in sheet **611** cannot touch the second guide-in sheet **75** because the first guide-in sheet **611** and the second guide-in sheet **75** are staggered in a left to right direction.

As shown in FIG. **38**, when the connection terminal **22** of the light and handy mobile disk **20** is inserted upwards into the space below the tongue **50**, two elastic sheets on two sides of the tongue **50** are pushed away and elastically moved outwards. Because the inner elastic sheets **42** on two sides of the top of the tongue rest against the top surface of the tongue **50**, the tongue **50** is also protected and cannot be broken when the light and handy mobile disk **20** is improperly inserted.

As shown in FIG. **40**, when the connection terminal of the USB 2.0 plug **10** having the metal housing is inserted upwardly into the connection slot, the USB 2.0 plug **10** occupies the entire chamber below the tongue **50** but does not occupy the entire chamber above the tongue. At this time, the outer elastic sheets **41** on two sides of the top of the tongue rest against the USB 2.0 plug **10** to prevent the USB 2.0 plug **10** from being rotated upwards and thus provide the effect of protecting the tongue **50**.

As shown in FIG. **41**, when the connection terminal of the USB 2.0 plug **10** is inserted downwardly into the connection slot, the USB 2.0 plug **10** occupies the entire chamber above the tongue **50** but does not occupy the entire chamber below the tongue. At this time, the outer elastic sheets **41** on two sides of the bottom of the tongue rest against the USB 2.0 plug **10** to prevent the USB 2.0 plug **10** from being rotated upwards to achieve the effect of protecting the tongue **50**.

12

The design of this embodiment has the effect of bidirectional insertion, and further has the effects of protecting the tongue and enlarging the contact area of the terminal.

As shown in FIG. **42**, the thirteenth embodiment of the invention is almost the same as the twelfth embodiment except that one of two laterally elastically movable outer elastic sheets **41** is formed on each of two sides of the metal housing **40** above and below the tongue **50** by prodding the metal housing **40** inwardly.

As shown in FIG. **43**, when the connection terminal of the USB 2.0 plug **10** is inserted upwardly into the connection slot, the outer elastic sheets **41** on two sides of the top of the tongue rest against the USB 2.0 plug **10**. As shown in FIG. **44**, when the connection terminal of the USB 2.0 plug **10** is inserted downwardly into the connection slot, the outer elastic sheets **41** on two sides of the bottom of the tongue rest against the USB 2.0 plug **10**.

As shown in FIG. **45**, the fourteenth embodiment of the invention is almost the same as the twelfth embodiment except that each of two sides of the metal housing **40** is prodded inwardly to form a laterally elastically movable middle elastic sheet **43**. The middle elastic sheet **43** is disposed at a middle height on one side of the connection slot **45** and has the structure the same as that of the outer elastic sheet **41**.

As shown in FIG. **46**, when the connection terminal of the light and handy mobile disk **20** is inserted upwardly into the connection slot **45**, the middle elastic sheets **43** on two sides of the tongue rest against one surface **23** of the light and handy mobile disk **20** formed with the connection terminal to prevent the light and handy mobile disk **20** from being rotated upwards. As shown in FIG. **47**, when the connection terminal of the light and handy mobile disk **20** is inserted downwardly into the connection slot, the middle elastic sheets **43** on two sides of the tongue rest against one surface of the light and handy mobile disk **20** formed with the connection terminal to prevent the light and handy mobile disk **20** from being rotated downwards.

As shown in FIG. **48**, the fifteenth embodiment of this invention is almost the same as the thirteenth and fourteenth embodiments. That is, each of two sides of the metal housing **40** is prodded inwardly to form a middle elastic sheet **43** and two outer elastic sheets **41**, which are laterally elastically movable.

As shown in FIG. **49**, the sixteenth embodiment of the invention is almost the same as the twelfth embodiment except that one end of the outer elastic sheet **41** and one end of the inner elastic sheet **42** are connected to two side plate surfaces of the metal housing **40** and extend outwardly in an arced manner. Each elastic sheet has a projection **46**. When the projection **46** is pressed, the elastic sheet is elastically moved outwardly.

As shown in FIG. **50**, the seventeenth embodiment of the invention is almost the same as the thirteenth embodiment except that the one end of the outer elastic sheet **41** of this embodiment is connected to the middle plate surface on each of two sides of the metal housing **40** and extends outwardly in an arced manner.

As shown in FIG. **51**, the eighteenth embodiment of the invention is almost the same as the fourteenth embodiment except that one end of the middle elastic sheet **43** of this embodiment is connected to the middle plate surface on each of two sides of the metal housing **40** and extends outwardly in an arced manner.

As shown in FIGS. **52** and **53**, the nineteenth embodiment of the invention is a USB 3.0 socket, which allows the plug to be inserted normally and oppositely, and is almost the

13

same as the twelfth embodiment except that this embodiment additionally has one row of first terminals **65** and one row of second terminals **90**. The contact **66** of the first terminal **65** lies on the top surface of the tongue **50** and is disposed in front of the contact **61** of the first terminal **60** on the same surface. The contact **91** of the second terminal **90** lies on the bottom surface of the tongue **50** and is disposed in front of the contact of the second terminal **70** on the same surface.

As shown in FIG. **54**, the 20th embodiment of the invention is almost the same as the twelfth embodiment except that the embodiment is a four-layer USB 2.0 socket that allows the USB plug to be normally and oppositely inserted for connection. That is, the plastic base **30** has four connection slots **35**, and the metal housing **40** has four openings corresponding to the four connection slots **35**.

As shown in FIG. **55**, the 21st embodiment of the invention is almost the same as the nineteenth embodiment except that this embodiment is a two-layer USB 3.0 socket that allows the plug to be normally and oppositely inserted. That is, the plastic base **30** has two connection slots **35**, and the metal housing **40** has two openings corresponding to the four connection slots **35**.

As shown in FIG. **56**, the 22nd embodiment of the invention is almost the same as the 20th embodiment except that this embodiment is a three-layer stacked socket. That is, the plastic base has, from bottom to top, a connection slot **35**, a connection slot **36** and a connection slot **37**. The metal housing **40** has three openings corresponding to the three connection slots, wherein the lowest slot is the connection slot **35** of the USB 3.0 socket that allows the plug to be normally and oppositely inserted, the middle slot is the connection slot **36** of the socket shared by the USB 3.0 and eSATA (External Serial ATA) plugs, and the upper slot is the connection slot **37** of the USB 2.0 socket that allows the plug to be inserted unidirectionally.

As shown in FIG. **57**, the 23rd embodiment of the invention is almost the same as the 21st embodiment except that this embodiment is a three-layer stacked socket. That is, the plastic base has, from bottom to top, a connection slot **35**, a connection slot **37** and a connection slot **38**. The metal housing **40** has three openings corresponding to the three connection slots, wherein the lowest connection slot **35** allows the USB 3.0 plug to be normally and oppositely inserted for connection, the middle connection slot **37** allows the USB 2.0 plug to be unidirectionally inserted for connection, and the upper connection slot **38** allows the 1394 plug to be inserted.

As shown in FIG. **58**, the 24th embodiment of the invention is a dual-slot USB 2.0 socket for bidirectional insertion and connection and is almost the same as the eighth embodiment except that the two connection slots **35** of this embodiment are arranged from left to right and have the insertion ports facing forward, and the tongues **50** in the connection slots **35** are in the upright state.

As shown in FIG. **59**, the 25th embodiment of the invention is a dual-slot USB 3.0 socket for bidirectional insertion and connection and is almost the same as the 24th embodiment. The two connection slots **35** are also arranged from left to right, and the tongues **50** in the connection slots **35** are in the upright state.

As shown in FIG. **60**, the 26th embodiment of the invention includes three sockets arranged from left to right and is almost the same as the 25th embodiment except that the leftmost connection slot **35** corresponds to the USB 2.0 socket for bidirectional insertion and connection, the middle connection slot **35** corresponds to the USB 3.0 socket for

14

bidirectional insertion and connection, and the rightmost connection slot **38** corresponds to the 1394 socket.

As shown in FIG. **61**, the 27th embodiment of the invention has three sockets arranged from left to right and is almost the same as the 26th embodiment except that the rightmost connection slot **36** is shared by the USB 3.0 and eSATA plugs.

As shown in FIG. **62**, the 28th embodiment of the invention is a dual-slot USB 2.0 socket for bidirectional insertion and connection, and is almost the same as the 24th embodiment except that this embodiment has upright slots **35**, and the insert ports of the connection slots **35** face upwards.

As shown in FIG. **63**, the 29th embodiment of the invention is almost the same as the 28th embodiment except that this embodiment is a dual-slot USB 3.0 socket for bidirectional insertion and connection.

As shown in FIG. **64**, the 30th embodiment of the invention is almost the same as the 29th embodiment except that this embodiment contains three upright slots. The leftmost connection slot **35** corresponds to the USB 3.0 socket for bidirectional insertion and connection, the middle connection slot **36** corresponds to the socket shared by the USB 3.0 and eSATA plugs, and the rightmost connection slot **38** corresponds to the 1394 socket.

As shown in FIG. **65**, the 31st embodiment of the invention is almost the same as the 30th embodiment except that the rightmost connection slot **39** of this embodiment is shared by the HDMI (High Definition Multimedia Interface) and display ports.

As shown in FIGS. **66** to **68**, the 32nd embodiment of the invention is a micro USB 2.0 socket, which includes a plastic base **30**, a metal housing **40**, one row of first terminals **60** and one row of second terminals **70**.

The plastic base **30** has two rows of terminal slots **31**. The front end of the terminal slot **31** is integrally formed with a projecting tongue **50**, and each of the top and bottom surfaces of the tongue **50** is formed with five terminal slots **59** separately arranged.

The metal housing **40** covers the plastic base **30**, the front section of the metal housing **40** is formed with a connection slot **45**, and the connection slot **45** is disposed on the front end of the plastic base **30** and covers the tongue **50** therein. The top and bottom ends are narrower than the middle section so that the four corners of its profile are formed with symmetric sloped edges **48**, and the top, bottom, left and right sides of the tongue **50** are formed with compatible and symmetrical profiles. Thus, a micro USB 2.0 plug may be bidirectionally inserted for connection. In addition, each of the top and bottom plates of the metal housing **40** is prodded to form two elastic locks **413**, and each of four sloped edges **48** of the front end of the connection slot **45** is formed with a slant guiding plate **47** expanding outwards. When the micro USB plug is inserted into the connection slot and touches the slant guiding plate **47**, it is guided toward the center of the connection slot.

The one row of first terminals **60** have five first terminals. Each first terminal **60** has a first contact **61**, a first fixing portion **63** and a first pin **64**. The first fixing portions **63** are fixed to the upper row of terminal slots **31** of the plastic base **30**. The first contact **61** cannot be elastically moved but lies in the terminal slot **59** on the top surface of the tongue **50**. The first pin **64** extends out of the bottom of the plastic base **30**.

The one row of second terminals **70** have five terminals. Each second terminal **70** has a second contact **71**, a second fixing portion **73** and a second pin **74**. The second fixing portions **73** are fixed to the lower row of terminal slots **31** of

15

the plastic base 30. The second contact 71 cannot be elastically moved and lies in the terminal slot 59 on the bottom of the tongue 50. The second pin 74 extends out of the plastic base 30 to the bottom thereof. The at least one row of first contacts 61 and the at least one row of second contacts 71 pertain to the same connection interface and have oppositely arranged serial numbers. That is, the one row of second contacts 71 have the serial numbers of 1, 2, 3, 4 and 5 from left to right, and the one row of first contacts 61 have the serial numbers of 5, 4, 3, 2 and 1 from left to right.

According to the above-mentioned structure, as shown in FIG. 69, the micro USB 2.0 plug 110 has a plastic base 114 and a metal casing covering the plastic base 114. The plastic base 114 has a connection slot 111 and one row of five connection terminals 112, and two elastic locks 113 on the top end surface. When the connection terminals 112 of the micro USB 2.0 plug 110 are upwardly and normally inserted into the connection slot 45, the connection slot 111 of the micro USB 2.0 plug is fitted with the tongue 50, and its one row of connection terminals 112 are electrically connected to the one row of second contacts 71 on the bottom side of the tongue 50. The two elastic projecting hooks 113 may hook on the rear sides of the elastic locks 413 of the top plate of the metal housing 40. As shown in FIG. 70, when the connection terminal 112 of the micro USB 2.0 plug 110 is downwardly and oppositely inserted into the connection slot 45, the one row of connection terminals 112 are electrically connected to the one row of first contacts 61 on the top surface of the tongue 50, and the two elastic locks 113 may engage with the rear sides of the two elastic locks 413 of the bottom plate of the metal housing 40. According to the above-mentioned description, it is obtained that the embodiment can allow the micro USB 2.0 plug 110 to be normally and oppositely inserted for electrical connection.

As shown in FIG. 71, when the micro USB 2.0 plug 110 is inserted into the connection slot 45 but is biased upward and not aligned with the slot, the micro USB 2.0 plug 110 touches the slant guiding plates 47 of two corners on the top of the connection slot 45. The micro USB 2.0 plug 110 is guided, by the slant surface of the slant guiding plate 47, to the center of the connection slot 45 so that the plug may be inserted in an aligned manner and the convenience in use may be obtained.

As shown in FIGS. 72 and 73, the 33rd embodiment of the invention is a mini USB 2.0 socket for bidirectional insertion and connection. The structure of this embodiment is almost the same as the structure of the eleventh embodiment and includes a plastic base 30, a metal housing 40, a tongue 50, one row of first terminals 60 and one row of second terminals 70. The difference therebetween is that the front sections of the top and bottom plate surfaces of the metal housing 40 of this embodiment are formed with four projections 49 projecting toward the connection slot 45. In addition, the structures of the one row of first terminals 60 and the one row of second terminals 70 are the same as the structures of the twelfth embodiment of FIG. 35. That is, the front end of the contact 61 of the first terminal 60 is formed with a downward guide-in sheet 611. The plate surface of the guide-in sheet 611 is smaller than the contact 61. The front end of the second contact 71 of the second terminal 70 is formed with an upward guide-in sheet 75. The plate surface of the guide-in sheet 75 is smaller than the contact 71. The guide-in sheets 611 and the guide-in sheets 75 are staggered in a left to right direction.

As shown in FIG. 74, when the mini USB 2.0 plug 120 is normally inserted into the socket, four projections 49 on the

16

top plate of the metal housing 40 push the mini USB 2.0 plug 120 downwards to prevent the metal casing 121 of the mini USB 2.0 plug 120 from touching the second terminal 70 to cause the short-circuited condition.

As shown in FIG. 75, when the mini USB 2.0 plug 120 is oppositely inserted into the socket, the four projections 49 on the bottom plate of the metal housing 40 push the mini USB 2.0 plug 120 upwards to prevent the metal casing 121 of the mini USB 2.0 plug 120 from touching the first terminal 60 to cause the short-circuited condition.

As shown in FIG. 76, the 34th embodiment of the invention is a micro USB socket for the bidirectional insertion and connection of the micro USB 2.0 plug and the unidirectional insertion and connection of the micro USB 3.0 plug. The structure of this embodiment is almost the same as the 32nd embodiment except that the plastic base 30 and the metal housing 40 of this embodiment are wider than those of the 32nd embodiment. The front section of the metal housing 40 is also formed with the wider connection slot 45. The socket of this embodiment further has a second tongue 510 and one row of five third terminals 100. The second tongue 510 integrally projects beyond the front end of the plastic base 30. The second tongue 510 and the tongue 50 are located on the same level and in parallel. However, the chambers above and below the second tongue 510 are not compatible with each other. The lower chamber is larger than the upper chamber. The chambers on the left and right sides of the connection slot 45 are not compatible. The one row of third terminals 100 are fixed to the plastic base 30. The third terminals 100 have third contacts 101 separately arranged on the bottom surface of the second tongue 510, and have pins extending out of the plastic base.

As shown in FIG. 77, when the micro USB 2.0 plug 110 is oppositely inserted into the connection slot 45, the connection terminal 112 of the micro USB 2.0 plug 110 is electrically connected to the first contact portion 61 on the top of the tongue 50.

As shown in FIG. 78, when the micro USB 2.0 plug 110 is normally inserted into the connection slot 45, the connection terminal 112 of the micro USB 2.0 plug 110 is electrically connected to the second contact portion 71 on the bottom of the tongue 50.

FIG. 80 is a cross-sectional view showing a micro USB 3.0 plug 115, which is almost the same as the micro USB 2.0 plug, and includes one row of five elastically movable connection terminals 117 on the left side, and one row of five elastically movable connection terminals 118 on the right side.

As shown in FIG. 79, when the micro USB 3.0 plug 115 is normally inserted into the connection slot 45, the one row of connection terminals 117 of the micro USB 3.0 plug 115 are electrically connected to one row of second contact portions 71 on the bottom of tongue 50, and the other row of connection terminals 118 of the micro USB 3.0 plug 115 are electrically connected to one row of third contact portions 101 on the bottom of the tongue 510.

As shown in FIG. 81, the 35th embodiment of the invention is a micro USB 3.0 socket for bidirectional insertion and connection of the micro USB 3.0 plug. The structure of this embodiment is almost the same as that of the 34th embodiment except that the chambers above and below the second tongue 510 are compatible and symmetrical, and the chambers on the left and right sides of the connection slot 45 are also compatible and symmetrical. The structure of this embodiment further has one row of five fourth terminals 105 fixed to the plastic base 30. The fourth terminals 105 have fourth contacts 106 separately arranged on the top surface of

the second tongue **510** and have pins extending out of the plastic base. The one row of first contacts **61** and the at least one row of third contacts **101** pertain to the same connection interface and have oppositely arranged serial numbers. As shown in FIG. **81**, the one row of first contacts **61** have the serial numbers of 10, 9, 8, 7 and 6 from left to right, and the one row of third contacts **101** have the serial numbers of 6, 7, 8, 9 and 10 from left to right. The one row of second contacts **71** and the one row of fourth contacts **106** pertain to the same connection interface and have oppositely arranged serial numbers. The one row of second contacts **71** have the serial numbers of 1, 2, 3, 4 and 5 from left to right, and the one row of fourth contacts **106** have the serial numbers of 5, 4, 3, 2 and 1 from left to right.

In addition, each of the top and bottom plates of the metal housing **40** is prodded to form with elastic pressing sheet **410** symmetrically arranged on the left and right sides. A positioning projection **412** and a guide-in slant sheet **411** are formed near two lateral sides. The elastic pressing sheet **410** extends inwards. Two sides of the two positioning projections **412** are separated from the metal housing **40**, and the front and rear ends of the two positioning projections **412** are connected to the metal housing **40**. When the micro USB 3.0 plug **115** is normally inserted into the connection slot **45**, the two guide-in slant sheets **411** may assist in guiding the plug.

As shown in FIG. **82**, when the micro USB 3.0 plug **115** is normally inserted into the connection slot **45**, the one row of connection terminals **117** of the micro USB 3.0 plug **115** are electrically connected to one row of second contact portions **71** on the bottom of the tongue **50**. The other row of connection terminals **118** of the micro USB 3.0 plug **115** are electrically connected to one row of third contact portions **101** on the bottom of the tongue **510**. The ten connection terminals are correspondingly electrically connected to the contact portions, wherein the connection terminal and the contact portion connected together have the same serial number. At this time, the elastic pressing sheet **410** and the positioning projection **412** of the top plate of the metal housing **40** may rest against the micro USB 3.0 plug **115** to form the better positioning effect. The positioning projection **412** of the bottom plate of the metal housing **40** may be positioned on one side of the micro USB 3.0 plug **115**.

As shown in FIG. **83**, when the micro USB 3.0 plug **115** is oppositely inserted into the connection slot **45**, the one row of connection terminals **117** of the micro USB 3.0 plug **115** are electrically connected to one row of fourth contact portions **106** on the top of the tongue **510**. The other row of connection terminals **118** of the micro USB 3.0 plug **115** are electrically connected to the one row of first contact portions **61** on the top of the tongue **50**. The ten connection terminals are correspondingly electrically connected to the contact portions, wherein the connection terminal and the contact portion connected together have the same serial number. At this time, the elastic pressing sheet **410** and the positioning projection **412** of the bottom plate of the metal housing **40** may rest against the micro USB 3.0 plug **115** to form the better positioning effect. The positioning projection **412** of the top plate of the metal housing **40** may be positioned on one side of the micro USB 3.0 plug **115**.

As shown in FIGS. **84** and **85**, the 36th embodiment of the invention is a micro USB 3.0 socket for bidirectional insertion and connection of the micro USB 3.0 plug. The structure of this embodiment is almost the same as the 35th embodiment except that this embodiment does not have the guide-in slant sheet, and only has the positioning projection

412. The positioning projection **412** has two sides connected to the metal housing **40**, and front and rear ends separated from the metal housing **40**.

Two surfaces of the tongue of the invention are formed with contacts, so there are many terminals arranged densely, and the high-frequency requirement is highly needed. The factors affecting the high frequency include the electroconductivity of the terminal, the cross-sectional area of the terminal, and the length of the terminal. In order to achieve the proper high frequency, the cross-sectional area and the length of the terminal need to be changed and then the high-frequency test has to be performed to obtain the desired high-frequency value.

Taking the USB 3.0 socket for bidirectional insertion and connection as an example, as shown in FIGS. **86** and **87**, when the high-frequency test does not reach the standard, the plate widths or the plate thicknesses of the two rows of first terminals **60** and **65** and the two rows of second terminals **70** and **90** may be increased so as to increase the frequency. As shown in FIGS. **88** and **89**, when the high-frequency test exceeds the standard, the plate widths or the plate thicknesses of the two rows of first terminals **60** and **65** and the two rows of second terminals **70** and **90** may be decreased, or the terminals may be curved to increase the lengths so as to decrease the frequency.

While the invention has been described by way of examples and in terms of preferred embodiments, it is to be understood that the invention is not limited thereto. To the contrary, it is intended to cover various modifications. Therefore, the scope of the appended claims should be accorded the broadest interpretation so as to encompass all such modifications.

What is claimed is:

[1. A socket structure with duplex electrical connection, the socket structure comprising:

- a plastic base;
- a connection slot, which is disposed in front of the plastic base and may be connected to a plug having at least one row of connection terminals;
- a tongue, which has a first surface and a second surface disposed opposite the first surface, and is disposed on one end of the plastic base and within the connection slot, such that chambers of the connection slot on two sides of the tongue make the plug be normally and oppositely inserted and positioned into the connection slot;
- at least one row of first contacts separately arranged on the first surface of the tongue, wherein each of the first contacts is electrically connected to a first pin extending out of the plastic base; and
- at least one row of second contacts separately arranged on the second surface of the tongue, wherein:
 - each of the second contacts is electrically connected to a second pin extending out of the plastic base;
 - when the plug is normally inserted into the connection slot with the at least one row of connection terminals of the plug are electrically connected to the at least one row of second contacts; and
 - when the plug is oppositely inserted into the connection slot with the at least one row of connection terminals of the plug facing the first surface of the tongue, the at least one row of connection terminals of the plug are electrically connected to the at least one row of first contacts.]

[2. The socket structure according to claim 1, wherein the at least one row of first contacts and the first pins are formed on at least one row of first terminals; the first terminal is

integrally formed with the first contact, a first extension, a first fixing portion and the first pin; the at least one row of second contacts and the second pins are formed on at least one row of second terminals; and the second terminal is integrally formed with the second contact, a second extension, a second fixing portion and the second pin.]

[3. The socket structure according to claim 2, wherein the first contacts of the row of first terminals and the second contacts of the row of second terminals respectively project beyond one of the surfaces of the tongue.]

[4. The socket structure according to claim 1, wherein the chambers of the connection slot on the two sides of the tongue are formed with compatible profiles, the at least one row of connection terminals are formed on only one of the surfaces of the plug, and the at least one row of connection terminals of the plug are electrically connected to only one of the rows of contacts on one of the surfaces of the tongue.]

[5. The socket structure according to claim 1, further comprising a metal housing covering the plastic base, wherein the tongue and the plastic base are integrally formed.]

[6. The socket structure according to claim 3, wherein the tongue is formed with through slots separately arranged, and the first contacts of the first terminals and the second contacts of the second terminals are elastically moved in correspondence with the through slots.]

[7. The socket structure according to claim 6, wherein the first contact of the first terminal and the second contact of the second terminal corresponding to the same one of the through slots are aligned with each other in a front to rear direction.]

[8. The socket structure according to claim 6, wherein the first contact of the first terminal and the second contact of the second terminal are parallel to each other in a left to right direction.]

[9. The socket structure according to claim 3, wherein:
the first contact of the first terminal is prodded and projects beyond a plate surface of the first extension, and one end of the first contact is connected to the first extension and gradually protrudes to the other end from front to rear and is opened; and
the second contact of the second terminal is prodded and projects beyond a plate surface of the second extension, and one end of the second contact is connected to the second extension and gradually protrudes to the other end from front to rear and is opened.]

[10. The socket structure according to claim 9, wherein the row of first terminals and the row of second terminals pertain to the same connection interface and have oppositely arranged serial numbers, and the first contact and the second contact are vertically aligned with each other.]

[11. The socket structure according to claim 1, wherein:
the tongue is a circuit board, first traces are formed on a top side of the tongue, and the first trace has the first contact on a front section of the tongue and a first connection terminal on a rear section of the tongue, the first connection terminal is electrically connected to the first pin; and
second traces are formed on a bottom side of the tongue, the second trace has the second contact on the front section of the tongue and a second connection terminal on the rear section of the tongue, and the second connection terminal is electrically connected to the second pin.]

[12. The socket structure according to claim 1, wherein the plug has a plastic base and a metal housing, the metal housing covers the plastic base, a chamber is formed

between the metal housing and the plastic base, and the chamber is fitted with the tongue when the plug is inserted into the connection slot.]

[13. The socket structure according to claim 1, wherein the plug does not have a metal housing, and when the plug is inserted into the connection slot, the plug may be connected to a top side or a bottom side of the tongue so that two plugs may be simultaneously connected to the top and bottom sides of the tongue.]

[14. The socket structure according to claim 1, wherein the at least one row of first contacts and the at least one row of second contacts pertain to the same connection interface and have oppositely arranged serial numbers, and the plug may be normally and oppositely inserted for electrical connection with the connection terminals of the plug facing upward or downward.]

[15. The socket structure according to claim 14 being a universal serial bus (USB) socket, wherein there are four rows of the first contacts and four rows of the second contacts.]

[16. The socket structure according to claim 14 being a mini universal serial bus (USB) socket, wherein there are five rows of the first contacts and five rows of the second contacts.]

[17. The socket structure according to claim 1, wherein the at least one row of first contacts and the at least one row of second contacts pertain to different connection interfaces, and may be respectively electrically connected to the plug and the other plug, which have the different connection interfaces.]

[18. The socket structure according to claim 1, wherein the tongue is disposed at a middle within the connection slot so that the connection slot is formed with symmetric profiles in up, down, left and right chambers of the tongue.]

[19. The socket structure according to claim 5, wherein at least one side of the metal housing projects inwardly to form at least one laterally elastically movable elastic sheet, and when the plug is inserted into the connection slot, the at least one elastic sheet may rest against the plug or the tongue to prevent the plug from turning.]

[20. The socket structure according to claim 19, wherein the at least one elastic sheet is a middle elastic sheet disposed at a middle height on one side of the connection slot, the plug does not have a metal housing, the plug may be connected to a top side or a bottom side of the tongue when the plug is inserted into the connection slot, and the middle elastic sheet rests against one of the surfaces of the plug formed with the connection terminals.]

[21. The socket structure according to claim 19, wherein the at least one elastic sheet comprises two outer elastic sheets, which are disposed above and below of the tongue on one side of the connection slot, the plug has a plastic base and a metal housing covering the plastic base, a chamber is formed between the metal housing and the plastic base, and when the plug is inserted into the connection slot, the chamber is fitted with the tongue, an elastic sheet on one side of the metal housing is pushed away by the plug, and the other elastic sheet rests against one of the surfaces of the plug.]

[22. The socket structure according to claim 21, wherein the at least one elastic sheet further comprises two inner elastic sheets disposed on inner sides of the two outer elastic sheets, and the two inner elastic sheets respectively rest against top and bottom surfaces on one side of the tongue.]

[23. The socket structure according to claim 21, wherein the at least one elastic sheet further comprises a middle elastic sheet disposed on an inner side of the two outer

21

elastic sheets and disposed at a middle height on one side of the connection slot, and when the plug does not have the metal housing, the plug inserted into the connection slot may be connected to a top side or a bottom side of the tongue, and the middle elastic sheet rests against one of the surfaces of the plug formed with the connection terminals.]

[24. The socket structure according to claim 19, wherein one end of the elastic sheet is connected to one side of the metal housing near a front end of the metal housing and extends inwardly in an arced manner, the elastic sheet has a projection, and the elastic sheet is elastically moved outwardly when the projection is pressed.]

[25. The socket structure according to claim 19, wherein one end of the elastic sheet is connected to a side plate surface of the metal housing and extends outwardly in an arced manner, the elastic sheet has a projection, and the elastic sheet is elastically moved outwardly when the projection is pressed.]

[26. The socket structure according to claim 3, wherein a front end of the first contact has a first guide-in sheet, a front end of the second contact has a second guide-in sheet, the first contact and the second contact are vertically aligned with each other, and the first guide-in sheet and second guide-in sheet are staggered in a left to right direction.]

[27. The socket structure according to claim 1, wherein the plastic base is further formed with at least another connection slot, and the another connection slot has at least one row of terminals to be connected to another plug.]

[28. The socket structure according to claim 14, wherein top and bottom ends of the connection slot are narrower than a middle section of the connection slot so that four corners of a profile of the connection slot have sloped edges.]

[29. The socket structure according to claim 28, wherein each of the four sloped edges on the front end of the connection slot is formed with a slant guiding plate expanding outwardly, and when the plug is inserted into the connection slot to touch the slant guiding plate, the plug is guided toward a center of the connection slot.]

[30. The socket structure according to claim 28 being a micro USB 2.0 socket, wherein each of the at least one row of first contacts and the at least one row of second contacts is a row of five connection terminals, which cannot be elastically moved.]

[31. The socket structure according to claim 1, further comprising:

a second tongue disposed within the connection slot, wherein the second tongue and the tongue are located on the same level and in parallel;

at least one row of third contacts separately arranged on one surface of the second tongue, wherein each of the third contacts is electrically connected to a pin extending out of the plastic base; and

at least one row of fourth contacts separately arranged on the other surface of the second tongue, wherein each of the fourth contacts is electrically connected to a pin extending out of the plastic base;

wherein the at least one row of first contacts and the at least one row of third contacts pertain to the same connection interface and have oppositely arranged serial numbers, the at least one row of second contacts and the at least one row of fourth contacts pertain to the same connection interface and have oppositely arranged serial numbers.]

[32. The socket structure according to claim 31 being a micro USB 3.0 socket, wherein each of the at least one row of first contacts, the at least one row of second contacts, the at least one row of third contacts and the at least one row of

22

fourth contacts has one row of five connection terminals, which cannot be elastically moved.]

[33. The socket structure according to claim 14, further comprising:

a second tongue disposed within the connection slot, wherein the second tongue and the tongue are located on the same level and in parallel; and

at least one row of third contacts separately arranged on one surface of the second tongue, wherein each of the third contacts is electrically connected to a pin extending out of the plastic base.]

34. A socket structure with duplex electrical connection, the socket structure comprising:

a plastic base;

a connection slot, which is disposed in front of the plastic base and configured to be connected to a plug having at least one row of connection terminals;

a tongue, which has a first surface with grooves, and a second surface with grooves, the second surface disposed opposite the first surface, the tongue being disposed on one end of the plastic base and within the connection slot, such that chambers of the connection slot on two sides of the tongue allow the plug to be normally and oppositely inserted and positioned into the connection slot;

at least one row of first contacts separately arranged on the first surface of the tongue, wherein each of the first contacts is electrically connected to a respective first pin extending out of the plastic base; and

at least one row of second contacts separately arranged on the second surface of the tongue, wherein:

each of the second contacts is electrically connected to a respective second pin extending out of the plastic base; the socket structure is operative to simultaneously electrically connect via the first and second contacts;

the at least one row of first contacts has a functional reverse mirror configuration relative to the at least one row of second contacts, and the socket structure is thereby configured for two separate operational states:

a first operational state when the plug is normally inserted into the connection slot with the at least one row of connection terminals of the plug facing the second surface of the tongue, the at least one row of connection terminals of the plug are electrically connected to the at least one row of second contacts and the tongue is disposed within the connection slot, wherein the connection slot is symmetric with symmetric up and down chambers, and symmetric left and right chambers around the tongue; and

a second operational state when the plug is oppositely inserted into the connection slot with the at least one row of connection terminals of the plug facing the first surface of the tongue, the at least one row of connection terminals of the plug are electrically connected to the at least one row of first contacts, and the tongue is disposed within the connection slot, wherein the connection slot is symmetric with symmetric up and down chambers, and symmetric left and right chambers around the tongue.

35. The socket structure of claim 34, wherein the tongue only contacts an interior portion of the plug when the plug is inserted.

36. The socket structure of claim 35, wherein a thickness of the tongue is less than a third of a height of the connection slot.

37. The socket structure of claim 34, wherein a portion of each of the first contacts, in the at least one row of first contacts, is coplanar with a portion of the first surface of the tongue.

38. The socket structure of claim 37, wherein a portion of each of the second contacts, in the at least one row of second contacts, is coplanar with a portion of the second surface of the tongue.

39. The socket structure of claim 34, further comprising a metal housing at least partially covering the plastic base.

40. The socket structure of claim 34, wherein the socket structure is a universal serial bus socket structure.

41. The socket structure of claim 34, wherein the tongue and the plastic base are integrally formed.

42. The socket structure of claim 34, wherein each contact of the first and second contacts is a portion of a respective terminal.

43. The socket structure of claim 34, wherein each of the first contacts is electrically connected to the respective first pin extending out of the plastic base through a rear cover and each of the second contacts is electrically connected to the respective second pin extending out of the plastic base through the rear cover.

44. The socket structure of claim 34, wherein at least two of the first contacts are not in electrical communication with one another, and at least two of the second contacts are not in electrical communication with one another.

45. The socket structure of claim 34, further comprising a rear cover attached to the plastic base.

46. The socket structure of claim 45, wherein each of the first contacts is electrically connected to the respective first pin extending out of the plastic base through the rear cover.

47. The socket structure of claim 45, wherein each of the second contacts is electrically connected to the respective second pin extending out of the plastic base through the rear cover.

48. The socket structure of claim 34, wherein the socket structure is operatively connected to the plug, and wherein the socket structure is operative to simultaneously electrically connect via the first and second contacts.

49. The socket structure of claim 34, wherein at least two of the first contacts are not in electrical communication with one another.

50. The socket structure of claim 34, wherein at least two of the second contacts are not in electrical communication with one another.

51. The socket structure of claim 34, wherein the at least one row of first contacts and respective first pins are located at ends of respective ones of a row of first terminals and the at least one row of second contacts and respective second pins are located at ends of respective ones of a row of second terminals.

52. The socket structure of claim 34, wherein a portion of a first contact projects beyond one surface of the tongue, and a portion of a second contact projects beyond another surface of the tongue.

53. The socket structure of claim 34, wherein a portion of one of the first contacts is at least partially included in the first surface with grooves.

54. The socket structure of claim 34, wherein a portion of one of the second contacts is at least partially included in the second surface with grooves.

55. An electrical connection system comprising the socket structure with the duplex electrical connection of claim 34 and the plug.

56. A socket structure with duplex electrical connection, the socket structure comprising:

a plastic base;

a connection slot, which is disposed in front of the plastic base and configured to be connected to a plug having at least one row of connection terminals;

a tongue, which has a top side with a first surface with grooves, and bottom side with a second surface with grooves, the second surface disposed opposite the first surface, the tongue being disposed on one end of the plastic base and within the connection slot, such that chambers of the connection slot on two sides of the tongue allow the plug to be normally and oppositely inserted and positioned into the connection slot;

at least one row of first contacts separately arranged on the first surface of the tongue, wherein each of the first contacts is electrically connected to a respective first pin extending out of the plastic base; and

at least one row of second contacts separately arranged on the second surface of the tongue, wherein:

each of the second contacts is electrically connected to a respective second pin extending out of the plastic base; the socket structure is operative to simultaneously electrically connect on the top and the bottom side of the tongue;

the at least one row of first contacts has a functional reverse mirror configuration relative to the at least one row of second contacts, and the socket structure is thereby configured for two separate operational states:

a first operational state when the plug is normally inserted into the connection slot with the at least one row of connection terminals of the plug facing the second surface of the tongue, the at least one row of connection terminals of the plug are electrically connected to the at least one row of second contacts; and a second operational state when the plug is oppositely inserted into the connection slot with the at least one row of connection terminals of the plug facing the first surface of the tongue, the at least one row of connection terminals of the plug are electrically connected to the at least one row of first contacts.

57. An electrical connection system comprising the socket structure with the duplex electrical connection of claim 56 and the plug, wherein the socket structure is operatively connected to the plug, and wherein the socket structure is operative to simultaneously electrically connect via the first and second contacts.

58. The socket structure of claim 56, wherein the tongue and the plastic base are integrally formed.

59. The socket structure of claim 58, further comprising a metal housing at least partially covering the plastic base.

60. The socket structure of claim 59, wherein at least two of the first contacts are not in electrical communication with one another and at least two of the second contacts are not in electrical communication with one another.

61. The socket structure of claim 60, wherein the grooves in the first surface of the tongue each include a portion of one of the first contacts, and the grooves in the second surface of the tongue each include a portion of one of the second contacts.

62. The socket structure of claim 61, wherein the at least one row of first contacts includes at least five contacts, and the at least one row of second contacts includes at least five contacts.

63. The socket structure of claim 62, wherein the tongue has chamfered corners on two sides of the tongue.

64. The socket structure of claim 63, wherein a tip of the tongue is tapered.

25

65. The socket structure of claim 64, wherein a thickness of the tongue is less than third of a height of the connection slot.

66. The socket structure of claim 65, wherein the socket structure is a universal serial bus socket structure.

67. A socket structure with duplex electrical connection, the socket structure comprising:

a plastic base;

a connection slot, which is disposed in front of the plastic base and configured to be connected to a plug having at least one row of connection terminals;

a tongue, which has a first surface with grooves, and a second surface with grooves, disposed opposite the first surface, the tongue being disposed on one end of the plastic base and within the connection slot, such that chambers of the connection slot on two sides of the tongue allow the plug to be normally and oppositely inserted and positioned into the connection slot based on an operational state when the socket structure is connected to the plug;

at least one row of first contacts separately arranged on the first surface of the tongue, wherein each of the first contacts is electrically connected to a respective first pin extending out of the plastic base; and

at least one row of second contacts separately arranged on the second surface of the tongue, wherein:

each of the second contacts is electrically connected to a respective second pin extending out of the plastic base; the at least one row of first contacts includes at least six contacts,

the at least one row of second contacts includes at least six contacts,

the socket structure is operative to simultaneously electrically connect via the first and second contacts;

the at least one row of first contacts has a reverse mirror configuration relative to the at least one row of second contacts, and the socket structure is thereby configured for two separate operational states:

a first operational state when the plug is normally inserted into the connection slot with the at least one row of connection terminals of the plug facing the second surface of the tongue, the at least one row of connection terminals of the plug are electrically connected to the at least one row of second contacts and the tongue is disposed within the connection slot, wherein the connection slot is symmetric with symmetric up and down chambers, and symmetric left and right chambers around the tongue; and

a second operational state when the plug is oppositely inserted into the connection slot with the at least one row of connection terminals of the plug facing the first surface of the tongue, the at least one row of connection terminals of the plug are electrically connected to the at least one row of first contacts, and the tongue is disposed within the connection slot, wherein the connection slot is symmetric with symmetric up and down chambers, and symmetric left and right chambers around the tongue.

68. An electrical connection system comprising the socket structure with the duplex electrical connection of claim 67 and the plug, wherein the socket structure is operatively connected to the plug, and wherein the socket structure is operative to simultaneously electrically connect via the first and second contacts.

69. The socket structure of claim 67, wherein the tongue and the plastic base are integrally formed.

26

70. The socket structure of claim 69, further comprising a metal housing at least partially covering the plastic base.

71. The socket structure of claim 70, wherein at least two of the first contacts are not in electrical communication with one another and at least two of the second contacts are not in electrical communication with one another.

72. The socket structure of claim 71, wherein the grooves in the first surface of the tongue each include a portion of one of the first contacts, and the grooves in the second surface of the tongue each include a portion of one of the second contacts.

73. The socket structure of claim 72, wherein the tongue has chamfered corners on two sides of the tongue.

74. The socket structure of claim 73, wherein a portion of the tongue opposite the plastic base is tapered.

75. The socket structure of claim 74, wherein a thickness of the tongue is less than third of a height of the connection slot.

76. The socket structure of claim 75, wherein the socket structure is a universal serial bus socket structure.

77. The socket structure of claim 76, wherein each of the first contacts is electrically connected to the respective first pin extending out of the plastic base through the rear cover, and each of the second contacts is electrically connected to the respective second pin extending out of the plastic base through the rear cover.

78. A socket structure with duplex electrical connection, the socket structure comprising:

a plastic base having a metal housing;

a connection slot, which is disposed in front of the plastic base and configured to be connected to a plug having at least one row of connection terminals;

a tongue, which has a first surface with grooves, and a second surface with grooves, disposed opposite the first surface, the tongue being disposed on one end of the plastic base and within the connection slot, such that chambers of the connection slot on two sides of the tongue allow the plug to be normally and oppositely inserted and positioned into the connection slot based on an operational state when the socket structure is connected to the plug;

at least one row of first contacts separately arranged on the first surface of the tongue, wherein each of the first contacts is electrically connected to a respective first pin extending out of the plastic base; and

at least one row of second contacts separately arranged on the second surface of the tongue, wherein:

each of the second contacts is electrically connected to a respective second pin extending out of the plastic base; the at least one row of first contacts includes at least four contacts,

the at least one row of second contacts includes at least four contacts,

the socket structure is operative to simultaneously electrically connect via the first and the second contacts;

the at least one row of first contacts has a reverse mirror configuration relative to the at least one row of second contacts, and the socket structure is thereby configured for two separate operational states:

a first operational state when the plug is normally inserted into the connection slot with the at least one row of connection terminals of the plug facing the second surface of the tongue, the at least one row of connection terminals of the plug are electrically connected to the at least one row of second contacts and the tongue is disposed at a central location within the connection slot, wherein the connection slot is symmet-

27

ric with symmetric up and down chambers, and symmetric left and right chambers around the tongue; and a second operational state when the plug is oppositely inserted into the connection slot with the at least one row of connection terminals of the plug facing the first surface of the tongue, the at least one row of connection terminals of the plug are electrically connected to the at least one row of first contacts, and the tongue is disposed at a central location within the connection slot, wherein the connection slot is symmetric with symmetric up and down chambers, and symmetric left and right chambers around the tongue.

79. An electrical connection system comprising the socket structure with the duplex electrical connection of claim 78 and the plug, wherein the socket structure is operatively connected to the plug, and wherein the socket structure is operative to simultaneously electrically connect via the first and second contacts.

80. The socket structure of claim 78, wherein the tongue and the plastic base are integrally formed.

81. The socket structure of claim 80, wherein the metal housing at least partially covers the plastic base.

82. The socket structure of claim 81, wherein at least two of the first contacts are not in electrical communication with one another and at least two of the second contacts are not in electrical communication with one another.

83. The socket structure of claim 82, wherein the grooves in the first surface of the tongue each include a portion of one of the first contacts, and the grooves in the second surface of the tongue each include a portion of one of the second contacts.

84. The socket structure of claim 83, wherein the tongue has chamfered corners on two sides of the tongue.

85. The socket structure of claim 84, wherein a portion of the tongue opposite the plastic base is tapered.

86. The socket structure of claim 85, wherein a thickness of the tongue is less than third of a height of the connection slot.

87. The socket structure of claim 86, wherein the socket structure is a universal serial bus socket structure and each of the first contacts is electrically connected to the respective first pin extending out of the plastic base through the rear cover, and each of the second contacts is electrically connected to the respective second pin extending out of the plastic base through the rear cover.

88. A socket structure with duplex electrical connection, the socket structure comprising:

a plastic base;

a connection slot, which is disposed in front of the plastic base and configured to be connected to a plug having at least one row of connection terminals;

a tongue, which has a first surface with grooves, and a second surface with grooves, the second surface disposed opposite the first surface, the tongue being disposed on one end of the plastic base and within the connection slot, such that chambers of the connection slot on two sides of the tongue allow the plug to be normally and oppositely inserted and positioned into the connection slot based on an operational state when the socket structure is connected to the plug;

at least one row of first contacts separately arranged on the first surface of the tongue, wherein each of the first contacts is electrically connected to a respective first pin extending out of the plastic base; and

at least one row of second contacts separately arranged on the second surface of the tongue, wherein:

28

each of the second contacts is electrically connected to a respective second pin extending out of the plastic base; the at least one row of first contacts includes more than four contacts,

the at least one row of second contacts includes more than four contacts,

the socket structure is operative to simultaneously electrically connect via the first and second contacts;

the at least one row of first contacts has a reverse mirror configuration relative to the at least one row of second contacts, and the socket structure is thereby configured for two separate operational states:

a first operational state when the plug is normally inserted into the connection slot with the at least one row of connection terminals of the plug facing the second surface of the tongue, the at least one row of connection terminals of the plug are electrically connected to the at least one row of second contacts and the tongue is disposed at a central location within the connection slot, wherein the connection slot is symmetric with symmetric up and down chambers, and symmetric left and right chambers around the tongue; and a second operational state when the plug is oppositely inserted into the connection slot with the at least one row of connection terminals of the plug facing the first surface of the tongue, the at least one row of connection terminals of the plug are electrically connected to the at least one row of first contacts, and the tongue is disposed at a central location within the connection slot, wherein the connection slot is symmetric with symmetric up and down chambers, and symmetric left and right chambers around the tongue.

89. An electrical connection system comprising the socket structure with the duplex electrical connection of claim 88 and the plug, wherein the socket structure is operatively connected to the plug, and wherein the socket structure is operative to simultaneously electrically connect via the first and second contacts.

90. The socket structure of claim 88, wherein the tongue and the plastic base are integrally formed.

91. The socket structure of claim 90, wherein the metal housing at least partially covers the plastic base.

92. The socket structure of claim 91, wherein at least two of the first contacts are not in electrical communication with one another and at least two of the second contacts are not in electrical communication with one another.

93. The socket structure of claim 92, wherein the grooves in the first surface of the tongue each include a portion of one of the first contacts, and the grooves in the second surface of the tongue each include a portion of one of the second contacts.

94. The socket structure of claim 93, wherein the tongue has chamfered corners on two sides of the tongue.

95. The socket structure of claim 94, wherein a portion of the tongue opposite the plastic base is tapered.

96. The socket structure of claim 95, wherein a thickness of the tongue is less than third of a height of the connection slot.

97. The socket structure of claim 96, wherein: the socket structure is a universal serial bus socket structure and each of the first contacts is electrically connected to the respective first pin extending out of the plastic base through the rear cover, and each of the second contacts is electrically connected to the respective second pin extending out of the plastic base through the rear cover,

29

the tongue only contacts an interior portion of the plug when the plug is inserted, each contact of the first and second contacts is a portion of a respective terminal, a portion of a first contact projects beyond one surface of the tongue, and a portion of a second contact projects beyond another surface of the tongue, the grooves in the first surface of the tongue each include a portion of one of the first contacts, and the grooves in the second surface of the tongue each include a portion of one of the second contacts.

98. A socket structure with duplex electrical connection, the socket structure comprising:

- a plastic base;
- a connection slot, which is disposed in front of the plastic base and configured to be connected to a plug having at least one row of connection terminals;
- a tongue, which has a first surface with grooves, and a second surface with grooves, the second surface disposed opposite the first surface, the tongue being disposed on one end of the plastic base and within the connection slot, such that chambers of the connection slot on two sides of the tongue allow the plug to be normally and oppositely inserted and positioned into the connection slot based on an operational state when the socket structure is connected to the plug;
- at least one row of first contacts separately arranged on the first surface of the tongue, wherein each of the first contacts is electrically connected to a respective first pin extending out of the plastic base; and
- at least one row of second contacts separately arranged on the second surface of the tongue, wherein:
 - each of the second contacts is electrically connected to a respective second pin extending out of the plastic base;
 - the socket structure is operative to simultaneously electrically connect via the first and second contacts;
 - the at least one row of first contacts has a functional reverse mirror configuration relative to the at least one row of second contacts, and the socket structure is thereby configured for two separate operational states: a first operational state when the plug is normally inserted into the connection slot with the at least one row of connection terminals of the plug facing the second surface of the tongue, the at least one row of connection terminals of the plug are electrically connected to the at least one row of second contacts and the tongue is disposed at a central location within the connection slot, wherein the connection slot is symmetric with symmetric up and down chambers, and symmetric left and right chambers around the tongue; and a second operational state when the plug is oppositely inserted into the connection slot with the at least one row of connection terminals of the plug facing the first surface of the tongue, the at least one row of connection terminals of the plug are electrically connected to the at least one row of first contacts, and the tongue is disposed at a central location within the connection slot, wherein the connection slot is symmetric with symmetric up and down chambers, and symmetric left and right chambers around the tongue.

99. An electrical connection system comprising the socket structure with the duplex electrical connection of claim 98 and the plug, wherein the socket structure is operatively connected to the plug, and wherein the socket structure is operative to simultaneously electrically connect via the first and second contacts.

30

100. The socket structure of claim 98, wherein the tongue and the plastic base are integrally formed.

101. The socket structure of claim 100, wherein the metal housing at least partially covers the plastic base.

102. The socket structure of claim 101, wherein at least two of the first contacts are not in electrical communication with one another and at least two of the second contacts are not in electrical communication with one another.

103. The socket structure of claim 102, wherein the grooves in the first surface of the tongue each include a portion of one of the first contacts, and the grooves in the second surface of the tongue each include a portion of one of the second contacts.

104. The socket structure of claim 103, wherein the tongue has chamfered corners on two sides of the tongue.

105. The socket structure of claim 104, wherein a portion of the tongue opposite the plastic base is tapered.

106. The socket structure of claim 105, wherein a thickness of the tongue is less than third of a height of the connection slot.

107. The socket structure of claim 106, wherein: the socket structure is a universal serial bus socket structure and each of the first contacts is electrically connected to the respective first pin extending out of the plastic base through the rear cover, and each of the second contacts is electrically connected to the respective second pin extending out of the plastic base through the rear cover, the tongue only contacts an interior portion of the plug when the plug is inserted, each contact of the first and second contacts is a portion of a respective terminal, a portion of a first contact projects beyond one surface of the tongue, and a portion of a second contact projects beyond another surface of the tongue, the grooves in the first surface of the tongue each include a portion of one of the first contacts, and the grooves in the second surface of the tongue each include a portion of one of the second contacts.

108. A socket structure with duplex electrical connection, the socket structure comprising:

- a plastic base;
- a metal housing at least partially covering the plastic base;
- a connection slot, which is disposed in front of the plastic base and configured to be connected to a plug having at least one row of connection terminals;
- a tongue, which has a first surface with grooves, and a second surface with grooves, the second surface disposed opposite the first surface, the tongue being disposed on one end of the plastic base and within the connection slot, such that chambers of the connection slot on two sides of the tongue allow the plug to be normally and oppositely inserted and positioned into the connection slot based on an operational state when the socket structure is connected to the plug;
- at least one row of first contacts separately arranged on the first surface of the tongue, wherein each of the first contacts is electrically connected to a respective first pin extending out of the plastic base; and
- at least one row of second contacts separately arranged on the second surface of the tongue; wherein:
 - each of the second contacts is electrically connected to a respective second pin extending out of the plastic base;
 - the socket structure is operative to simultaneously electrically connect via the first and second contacts;

31

the at least one row of first contacts has a functional reverse mirror configuration relative to the at least one row of second contacts, and the socket structure is thereby configured for two separate operational states:

a first operational state when the plug is normally inserted into the connection slot with the at least one row of connection terminals of the plug facing the second surface of the tongue, the at least one row of connection terminals of the plug are electrically connected to the at least one row of second contacts and the tongue is disposed at a central location within the connection slot, wherein the connection slot is symmetric with symmetric up and down chambers, and symmetric left and right chambers around the tongue; and

a second operational state when the plug is oppositely inserted into the connection slot with the at least one row of connection terminals of the plug facing the first surface of the tongue, the at least one row of connection terminals of the plug are electrically connected to the at least one row of first contacts, and the tongue is disposed at a central location within the connection slot, wherein the connection slot is symmetric with symmetric up and down chambers, and symmetric left and right chambers around the tongue,

the socket structure is a universal serial bus socket structure and each of the first contacts is electrically connected to the respective first pin extending out of the plastic base through a rear cover, and each of the second contacts is electrically connected to the respective second pin extending out of the plastic base through the rear cover,

the tongue only contacts an interior portion of the plug when the plug is inserted,

each contact of the first and second contacts is connected to a respective portion of a respective terminal,

the grooves in the first surface of the tongue each include a at least a portion of respective ones of the first contacts, and

the grooves in the second surface of the tongue each include at least a portion of respective ones of the second contacts.

109. An electrical connection socket and plug comprising the socket structure of claim 108 and the plug, wherein the socket structure is operatively connected to the plug, and wherein the socket structure is operative to simultaneously electrically connect via the first and second contacts.

110. A socket structure with duplex electrical connection, the socket structure comprising:

a plastic base;

a metal housing at least partially covering the plastic base;

a connection slot, which is disposed in front of the plastic base and configured to be connected to a plug having at least one row of connection terminals;

a tongue, which has a top side with a first surface with grooves, and a bottom side with a second surface with grooves, the second surface disposed opposite the first surface, the tongue being disposed on one end of the plastic base and within the connection slot, such that chambers of the connection slot on two sides of the tongue allow the plug to be normally and oppositely inserted and positioned into the connection slot based on an operational state when the socket structure is connected to the plug;

at least one row of first contacts separately arranged on the first surface of the tongue, wherein each of the first

32

contacts is electrically connected to a respective first pin extending out of the plastic base; and

at least one row of second contacts separately arranged on the second surface of the tongue, wherein:

each of the second contacts is electrically connected to a respective second pin extending out of the plastic base;

the socket structure is operative to simultaneously electrically connect on the top and the bottom side of the tongue;

the at least one row of first contacts has a reverse mirror configuration relative to the at least one row of second contacts, and the socket structure is thereby configured for two separate operational states:

a first operational state when the plug is normally inserted into the connection slot with the at least one row of connection terminals of the plug facing the second surface of the tongue, the at least one row of connection terminals of the plug are electrically connected to the at least one row of second contacts and the tongue is disposed at a central location within the connection slot, wherein the connection slot is symmetric with symmetric up and down chambers, and symmetric left and right chambers around the tongue; and

a second operational state when the plug is oppositely inserted into the connection slot with the at least one row of connection terminals of the plug facing the first surface of the tongue, the at least one row of connection terminals of the plug are electrically connected to the at least one row of first contacts, and the tongue is disposed at a central location within the connection slot, wherein the connection slot is symmetric with symmetric up and down chambers, and symmetric left and right chambers around the tongue,

the socket structure is a universal serial bus socket structure and each of the first contacts is electrically connected to the respective first pin extending out of the plastic base through a rear cover, and each of the second contacts is electrically connected to the respective second pin extending out of the plastic base through the rear cover,

the tongue only contacts an interior portion of the plug when the plug is inserted,

each contact of the first and second contacts is a portion of a respective terminal,

the grooves in the first surface of the tongue each include a respective portion of respective ones of the first contacts,

the grooves in the second surface of the tongue each include a portion of respective ones of the second contacts,

a portion of the tongue opposite the plastic base is tapered, and

the tongue has chamfered edges on two opposite sides of the tongue.

111. An electrical connection socket and plug comprising the socket structure of claim 110 and the plug, wherein the socket structure is operatively connected to the plug, and wherein the socket structure is operative to simultaneously electrically connect via the first and second contacts.

112. A socket structure with duplex electrical connection, the socket structure comprising:

a plastic base;

a metal housing at least partially covering the plastic base;

a connection slot, which is disposed in front of the plastic base and configured to be connected to a plug having at least one row of connection terminals;

33

a tongue, which has a top side with a first surface with grooves, and bottom side with a second surface with grooves, the second surface disposed opposite the first surface, the tongue being disposed on one end of the plastic base and within the connection slot, such that chambers of the connection slot on two sides of the tongue allow the plug to be normally and oppositely inserted and positioned into the connection slot based on an operational state when the socket structure is connected to the plug;

at least one row of first contacts separately arranged on the first surface of the tongue, wherein each of the first contacts is electrically connected to a respective first pin extending out of the plastic base; and

at least one row of second contacts separately arranged on the second surface of the tongue, wherein:

each of the second contacts is electrically connected to a respective second pin extending out of the plastic base; the socket structure is operative to simultaneously electrically connect on the top and the bottom side of the tongue;

the at least one row of first contacts has a functional reverse mirror configuration relative to the at least one row of second contacts, and the socket structure is thereby configured for two separate operational states:

a first operational state when the plug is normally inserted into the connection slot with the at least one row of connection terminals of the plug facing the second surface of the tongue, the at least one row of connection terminals of the plug are electrically connected to the at least one row of second contacts and the tongue is disposed at a central location within the connection slot, wherein the connection slot is symmetric with symmetric up and down chambers, and symmetric left and right chambers around the tongue; and

a second operational state when the plug is oppositely inserted into the connection slot with the at least one row of connection terminals of the plug facing the first surface of the tongue, the at least one row of connection terminals of the plug are electrically connected to the at least one row of first contacts, and the tongue is disposed at a central location within the connection slot, wherein the connection slot is symmetric with symmetric up and down chambers, and symmetric left and right chambers around the tongue,

the socket structure is a universal serial bus socket structure and each of the first contacts is electrically connected to the respective first pin extending out of the plastic base through a rear cover, and each of the second contacts is electrically connected to the respective second pin extending out of the plastic base through the rear cover,

the tongue only contacts an interior portion of the plug when the plug is inserted,

each contact of the first and second contacts is connected to a portion of a respective terminal,

the grooves in the first surface of the tongue each include at least a portion of respective ones of the first contacts, the grooves in the second surface of the tongue each include at least a portion of respective ones of the second contacts,

a portion of the tongue opposite the plastic base is tapered,

a thickness of the tongue, in at least one portion, is less than third of a height of the connection slot, and

the tongue has chamfered edges on two opposite sides of the tongue.

34

113. An electrical connection socket and plug comprising the socket structure of claim 112 and the plug, wherein the socket structure is operatively connected to the plug, and wherein the socket structure is operative to simultaneously electrically connect via the first and second contacts.

114. A socket structure with duplex electrical connection, the socket structure comprising:

a plastic base;

a connection slot, which is disposed in front of the plastic base and configured to be connected to a plug having at least one row of connection terminals;

a tongue, which has a first surface and a second surface disposed opposite the first surface and is disposed on one end of the plastic base and within the connection slot, such that chambers of the connection slot on two sides of the tongue allow the plug to be normally and oppositely inserted and positioned into the connection slot based on an operational state when the socket structure is connected to the plug;

at least one row of first contacts separately arranged on the first surface of the tongue, wherein each of the first contacts is electrically connected to a respective first pin extending out of the plastic base; and

at least one row of second contacts separately arranged on the second surface of the tongue, wherein:

each of the second contacts is electrically connected to a respective second pin extending out of the plastic base; the socket structure is operative to simultaneously electrically connect via the first and second contacts;

the at least one row of first contacts has a functional reverse mirror configuration relative to the at least one row of second contacts, and the socket structure is thereby configured for two separate operational states:

a first operational state when the plug is normally inserted into the connection slot with the at least one row of connection terminals of the plug facing the second surface of the tongue, the at least one row of connection terminals of the plug are electrically connected to the at least one row of second contacts and the tongue is centrally located within the connection slot, wherein the connection slot is symmetric with up, down, left and right chambers around the tongue; and

a second operational state when the plug is oppositely inserted into the connection slot with the at least one row of connection terminals of the plug facing the first surface of the tongue, the at least one row of connection terminals of the plug are electrically connected to the at least one row of first contacts, and the tongue is centrally located within the connection slot, wherein the connection slot is symmetric with symmetric up and down chambers, and symmetric left and right chambers around the tongue.

115. A socket structure with duplex electrical connection, the socket structure comprising:

a plastic base;

a connection slot, which is disposed in front of the plastic base and configured to be connected to a plug having at least one row of connection terminals;

a tongue, which has a top side with a first castellated surface and bottom side with a second castellated surface disposed opposite the first castellated surface and is disposed on one end of the plastic base and within the connection slot, such that chambers of the connection slot on two sides of the tongue allow the plug to be normally and oppositely inserted and positioned into the connection slot based on an operational state when the socket structure is connected to the plug;

35

at least one row of first contacts separately arranged on the first castellated surface of the tongue, wherein each of the first contacts is electrically connected to a respective first pin extending out of the plastic base; and

at least one row of second contacts separately arranged on the second castellated surface of the tongue, wherein:

each of the second contacts is electrically connected to a respective second pin extending out of the plastic base, the socket structure is operative to electrically connect on the top side, the bottom side, and the top side and the bottom side of the tongue; and

the socket structure is thereby configured for two separate operational states:

a first operational state when the plug is normally inserted into the connection slot with the at least one row of connection terminals of the plug facing the second castellated surface of the tongue, the at least one row of connection terminals of the plug are electrically connected to the at least one row of second contacts and the tongue is centrally located within the connection slot, wherein the connection slot is symmetric with up, down, left and right chambers around the tongue; and

a second operational state when the plug is oppositely inserted into the connection slot with the at least one row of connection terminals of the plug facing the first castellated surface of the tongue, the at least one row of connection terminals of the plug are electrically connected to the at least one row of first contacts, and the tongue is centrally located within the connection slot, wherein the connection slot is symmetric with symmetric up and down chambers, and symmetric left and right chambers around the tongue.

116. A socket structure with duplex electrical connection, the socket structure comprising:

a plastic base;

a connection slot, which is disposed in front of the plastic base and configured to be connected to a plug having at least one row of connection terminals;

a tongue, which has a first surface and a second surface disposed opposite the first surface and is disposed on one end of the plastic base and within the connection slot, such that chambers of the connection slot on two sides of the tongue allow the plug to be normally and oppositely inserted and positioned into the connection slot based on an operational state when the socket structure is connected to the plug;

at least one row of first contacts separately arranged on the first surface of the tongue, wherein each of the first contacts is electrically connected to a respective first pin extending out of the plastic base, wherein a first portion of each of the first contacts is proud of a top-most surface of the tongue; and

at least one row of second contacts separately arranged on the second surface of the tongue, wherein a second portion of each of the second contacts is proud of a bottom-most surface of the tongue, and

the socket structure is operative to simultaneously electrically connect on both sides of the tongue via the first and second contacts, wherein:

each of the second contacts is electrically connected to a respective second pin extending out of the plastic base; and

the socket structure is thereby configured for two separate operational states:

36

a first operational state when the plug is normally inserted into the connection slot with the at least one row of connection terminals of the plug facing the second surface of the tongue, the at least one row of connection terminals of the plug are electrically connected to the at least one row of second contacts and the tongue is disposed at a middle within the connection slot, wherein the connection slot is symmetric with symmetric up and down chambers, and symmetric left and right chambers around the tongue; and

a second operational state when the plug is oppositely inserted into the connection slot with the at least one row of connection terminals of the plug facing the first surface of the tongue, the at least one row of connection terminals of the plug are electrically connected to the at least one row of first contacts, and the tongue is disposed at within the connection slot, wherein the connection slot is symmetric with symmetric up and down chambers, and symmetric left and right chambers around the tongue.

117. A socket structure with duplex electrical connection, the socket structure comprising:

a plastic base;

a connection slot, which is disposed in front of the plastic base and configured to be connected to a plug having at least one row of connection terminals;

a tongue, which has a top side with a first surface and bottom side with a second surface disposed opposite the first surface, and the tongue is disposed on one end of the plastic base and within the connection slot, such that chambers of the connection slot on two sides of the tongue allow the plug to be normally and oppositely inserted and positioned into the connection slot based on an operational state when the socket structure is connected to the plug;

at least one row of first contacts separately arranged on the first surface of the tongue, wherein each of the first contacts is electrically connected to a respective first pin extending out of the plastic base; and

at least one row of second contacts separately arranged on the second surface of the tongue, wherein:

each of the second contacts is electrically connected to a respective second pin extending out of the plastic base; the socket structure is operative to electrically connect on the top side, the bottom side, and the top side and the bottom side of the tongue; and

the socket structure is thereby configured for two separate operational states:

a first operational state when the plug is normally inserted into the connection slot with the at least one row of connection terminals of the plug facing the second surface of the tongue, the at least one row of connection terminals of the plug are electrically connected to the at least one row of second contacts and the tongue is centrally located within the connection slot, wherein the connection slot is symmetric with symmetric up and down chambers, and symmetric left and right chambers around the tongue; and

a second operational state when the plug is oppositely inserted into the connection slot with the at least one row of connection terminals of the plug facing the first surface of the tongue, the at least one row of connection terminals of the plug are electrically connected to the at least one row of first contacts, and the tongue is centrally located within the connection, wherein the

37

connection slot is symmetric with symmetric up and down chambers, and symmetric left and right chambers around the tongue.

118. A socket structure with duplex electrical connection, the socket structure comprising:

a plastic base;

a connection slot, which is disposed in front of the plastic base and configured to be connected to a plug having at least one row of connection terminals;

a tongue, which has a top side with a first surface and a bottom side with a second surface disposed opposite the first surface, and the tongue is disposed on one end of the plastic base and within the connection slot, such that chambers of the connection slot on two sides of the tongue allow the plug to be normally and oppositely inserted and positioned into the connection slot based on an operational state when the socket structure is connected to the plug;

at least one row of first contacts separately arranged on the first surface of the tongue, wherein each of the first contacts is electrically connected to a respective first pin extending out of the plastic base; and

at least one row of second contacts separately arranged on the second surface of the tongue, wherein:

each of the second contacts is electrically connected to a respective second pin extending out of the plastic base; the at least one row of first contacts has a functional reverse mirror configuration relative to the at least one row of second contacts;

the socket structure is operative to electrically connect on the top side, the bottom side, and the top side and the bottom side of the tongue; and

the socket structure is thereby configured for two separate operational states:

a first operational state when the plug is normally inserted into the connection slot with the at least one row of connection terminals of the plug facing the second surface of the tongue, the at least one row of connection terminals of the plug are electrically connected to the at least one row of second contacts and the tongue is centrally located within the connection slot, wherein the connection slot is symmetric with symmetric up and down chambers, and symmetric left and right chambers around the tongue; and

a second operational state when the plug is oppositely inserted into the connection slot with the at least one row of connection terminals of the plug facing the first surface of the tongue, the at least one row of connection terminals of the plug are electrically connected to the at least one row of first contacts, and the tongue is centrally located within the connection slot, wherein the connection slot is symmetric with symmetric up and down chambers, and symmetric left and right chambers around the tongue.

119. A socket structure with duplex electrical connection, the socket structure comprising:

a plastic base;

a connection slot, which is disposed in front of the plastic base and configured to be connected to a plug having at least one row of connection terminals;

a tongue, which has a top side a first surface and a bottom side with a second surface disposed opposite the first surface, and the tongue is disposed on one end of the plastic base and within the connection slot, such that chambers of the connection slot on two sides of the tongue allow the plug to be normally and oppositely

38

inserted and positioned into the connection slot based on an operational state when the socket structure is connected to the plug;

at least one row of first contacts separately arranged on the first surface of the tongue, wherein each of the first contacts is electrically connected to a first pin extending out of the plastic base; and

at least one row of second contacts separately arranged on the second surface of the tongue, wherein:

each of the second contacts is electrically connected to a second pin extending out of the plastic base; the socket structure is operative to electrically connect on the top side, the bottom side, and the top side and the bottom side of the tongue; and

the socket structure is thereby configured for two separate operational states:

a first operational state when the plug is normally inserted into the connection slot with the at least one row of connection terminals of the plug facing the second surface of the tongue, the at least one row of connection terminals of the plug are electrically connected to the at least one row of second contacts and the tongue is disposed at a middle within the connection slot, wherein the connection slot is symmetric with symmetric up and down chambers, and symmetric left and right chambers around the tongue; and

a second operational state when the plug is oppositely inserted into the connection slot with the at least one row of connection terminals of the plug facing the first surface of the tongue, the at least one row of connection terminals of the plug are electrically connected to the at least one row of first contacts, and the tongue is disposed at within the connection slot, wherein the connection slot is symmetric with symmetric up and down chambers, and symmetric left and right chambers around the tongue.

120. A socket structure with duplex electrical connection, the socket structure comprising:

a plastic base;

a connection slot, which is disposed in front of the plastic base and configured to be connected to a plug having at least one row of connection terminals;

a tongue, which has a top side with a first surface and a bottom side with a second surface disposed opposite the first surface, and the tongue is disposed on one end of the plastic base and within the connection slot, such that chambers of the connection slot on two sides of the tongue allow the plug to be normally and oppositely inserted and positioned into the connection slot based on an operational state when the socket structure is connected to the plug;

at least one row of first contacts separately arranged on the first surface of the tongue, wherein each of the first contacts is electrically connected to a first pin extending out of the plastic base; and

at least one row of second contacts separately arranged on the second surface of the tongue, wherein:

each of the second contacts is electrically connected to a second pin extending out of the plastic base; the socket structure is operative to electrically connect on the top side, the bottom side, and the top side and the bottom side of the tongue; and

the socket structure is thereby configured for two separate operational states:

a first operational state when the plug is normally inserted into the connection slot with the at least one row of connection terminals of the plug facing the

second surface of the tongue, the at least one row of connection terminals of the plug are electrically connected to the at least one row of second contacts and the tongue is centrally located within the connection slot, wherein the connection slot is symmetric with symmetric up and down chambers, and symmetric left and right chambers around the tongue; and

a second operational state when the plug is oppositely inserted into the connection slot with the at least one row of connection terminals of the plug facing the first surface of the tongue, the at least one row of connection terminals of the plug are electrically connected to the at least one row of first contacts, and the tongue is centrally located within the connection slot, wherein the connection slot is symmetric with symmetric up and down chambers, and symmetric left and right chambers around the tongue.

121. A socket structure configured for a duplex electrical connection, the socket structure comprising:

- a plastic base;
- a connection slot, which is disposed in front of the plastic base and configured to be connected to a plug having at least one row of connection terminals;
- a tongue, which has a first surface and a second surface disposed opposite the first surface, and is disposed on one end of the plastic base and within the connection slot, such that chambers of the connection slot on two sides of the tongue allow the plug to be normally and oppositely inserted and positioned into the connection slot,
- at least one row of first contacts separately arranged on the first surface of the tongue, wherein each of the first contacts is electrically connected to a respective first pin extending out of the plastic base; and
- at least one row of second contacts separately arranged on the second surface of the tongue, wherein:
 - each of the second contacts is electrically connected to a respective second pin extending out of the plastic base;
 - the at least one row of first contacts have increasing assigned serial numbers in a first direction and the at least second row of second contacts have decreasing assigned serial numbers in the first direction;
- when the plug is normally inserted into the connection slot with the at least one row of connection terminals of the plug facing the second surface of the tongue, the at least one row of connection terminals of the plug are electrically connected to the at least one row of second contacts, and the tongue is disposed at central location within the connection slot so that the connection slot is formed with up and down chambers, and left and right chambers around the tongue with the up and down chambers being symmetrical, and the left and right chambers being symmetrical; and
- when the plug is oppositely inserted into the connection slot with the at least one row of connection terminals of the plug facing the first surface of the tongue, the at least one row of connection terminals of the plug are electrically connected to the at least one row of first contacts, and the tongue is disposed at the middle within the connection slot so that the connection slot is formed with symmetric profiles in up, down, left and right chambers around the tongue with the up and down chambers being symmetrical, and the left and right chambers being symmetrical; and
- the tongue operative for signal transmission on one side when connected in a first configuration, and operative

for signal transmission simultaneously on both sides when connected in a second configuration.

122. The socket structure of claim 121, wherein the first and the second surfaces of the tongue are castellated, and wherein the first contacts are at least partially on a grooved portion of the first surface such that at least a portion of the first contacts are proud of the first surface, and the second contacts are at least partially on a grooved portion of the second surface such that at least a portion of the second contacts are proud of the second surface.

123. The socket structure of claim 121, wherein a thickness of the tongue is less than third of a height of the connection slot.

124. A socket structure configured for a duplex electrical connection, the socket structure comprising:

- a plastic base;
- a connection slot, which is disposed in front of the plastic base and configured to be connected to a plug having at least one row of connection terminals;
- a tongue, which has a first surface and a second surface disposed opposite the first surface, and is disposed on one end of the plastic base and within the connection slot, such that chambers of the connection slot on two sides of the tongue allow the plug to be normally and oppositely inserted and positioned into the connection slot,
- at least one row of first contacts separately arranged on the first surface of the tongue, wherein each of the first contacts is electrically connected to a respective first pin extending out of the plastic base; and
- at least one row of second contacts separately arranged on the second surface of the tongue; wherein:
 - each of the second contacts is electrically connected to a respective second pin extending out of the plastic base;
 - the at least one row of first contacts have increasing assigned serial numbers in a first direction and the at least second row of second contacts have decreasing assigned serial numbers in the first direction;
- when the plug is normally inserted into the connection slot with the at least one row of connection terminals of the plug facing the second surface of the tongue, the at least one row of connection terminals of the plug are electrically connected to the at least one row of second contacts, and the tongue is disposed at central location within the connection slot so that the connection slot is formed with up and down chambers, and left and right chambers around the tongue with the up and down chambers being symmetrical, and the left and right chambers being symmetrical; and
- when the plug is oppositely inserted into the connection slot with the at least one row of connection terminals of the plug facing the first surface of the tongue, the at least one row of connection terminals of the plug are electrically connected to the at least one row of first contacts, and the tongue is disposed at the middle within the connection slot so that the connection slot is formed with symmetric profiles in up, down, left and right chambers around the tongue with the up and down chambers being symmetrical, and the left and right chambers being symmetrical; and
- the tongue is operative for signal transmission on one side when connected in a first configuration, and operative for signal transmission simultaneously on both sides when connected in a second configuration; and
- the socket structure is further operative to receive one of two different types of universal serial bus plugs.

41

125. The socket structure of claim 124, wherein the first and the second surfaces of the tongue are castellated, and wherein the first contacts are at least partially placed in grooves of the first surface such that at least a portion of the first contacts are proud of the first surface, and the second contacts are at least partially placed in grooves of the second surface such that at least a portion of the second contacts are proud of the second surface.

126. The socket structure of claim 124, wherein a thickness of the tongue is less than third of a height of the connection slot.

127. A socket structure configured for a duplex electrical connection, the socket structure comprising:

a plastic base;

a connection slot, which is disposed in front of the plastic base and configured to be connected to a plug having at least one row of connection terminals;

a tongue, which has a first surface and a second surface disposed opposite the first surface, and is disposed on one end of the plastic base and within the connection slot, such that chambers of the connection slot on two sides of the tongue allow the plug to be normally and oppositely inserted and positioned into the connection slot,

at least one row of first contacts separately arranged on the first surface of the tongue, wherein each of the first contacts is electrically connected to a respective first pin extending out of the plastic base; and

at least one row of second contacts separately arranged on the second surface of the tongue, wherein:

each of the second contacts is electrically connected to a respective second pin extending out of the plastic base; the at least one row of first contacts have increasing assigned serial numbers in a first direction and the at least second row of second contacts have decreasing assigned serial numbers in the first direction;

when the plug is normally inserted into the connection slot with the at least one row of connection terminals of the plug facing the second surface of the tongue, the at least one row of connection terminals of the plug are electrically connected to the at least one row of second contacts, and the tongue is disposed at central location within the connection slot so that the connection slot is formed with up and down chambers, and left and right chambers around the tongue with the up and down chambers being symmetrical, and the left and right chambers being symmetrical; and

when the plug is oppositely inserted into the connection slot with the at least one row of connection terminals of the plug facing the first surface of the tongue, the at least one row of connection terminals of the plug are electrically connected to the at least one row of first contacts, and the tongue is disposed at the middle within the connection slot so that the connection slot is formed with symmetric profiles in up, down, left and right chambers around the tongue with the up and down chambers being symmetrical, and the left and right chambers being symmetrical; and

the tongue is operative for signal transmission on one side when connected in a first configuration, and operative for signal transmission simultaneously on both sides when connected in a second configuration; and

the socket structure is further operative to receive one of two different styles of universal serial bus plugs.

128. The socket structure of claim 127, wherein the first and the second surfaces of the tongue are castellated, and

42

wherein the first contacts are at least partially placed in grooves of the first surface such that at least a portion of the first contacts are proud of the first surface, and the second contacts are at least partially placed in grooves of the second surface such that at least a portion of the second contacts are proud of the second surface.

129. The socket structure of claim 127, wherein a thickness of the tongue is less than third of a height of the connection slot.

130. A socket structure with duplex electrical connection, the socket structure comprising:

a plastic base;

a connection slot, which is disposed in front of the plastic base and configured to be connected to a plug having at least one row of connection terminals;

a tongue, which has a first surface with recesses, and a second surface with recesses, the second surface disposed opposite the first surface, the tongue being disposed on one end of the plastic base and within the connection slot, such that chambers of the connection slot on two sides of the tongue allow the plug to be normally and oppositely inserted and positioned into the connection slot;

at least one row of first contacts separately arranged on the first surface of the tongue, wherein each of the first contacts is electrically connected to a respective first pin extending out of the plastic base; and

at least one row of second contacts separately arranged on the second surface of the tongue, wherein:

each of the second contacts is electrically connected to a respective second pin extending out of the plastic base; the socket structure is operative to simultaneously electrically connect via the first and second contacts;

the at least one row of first contacts has a functional reverse mirror configuration relative to the at least one row of second contacts, and the socket structure is thereby configured for two separate operational states:

a first operational state when the plug is normally inserted into the connection slot with the at least one row of connection terminals of the plug facing the second surface of the tongue, the at least one row of connection terminals of the plug are electrically connected to the at least one row of second contacts and the tongue is disposed within the connection slot, wherein the connection slot is symmetric with symmetric up and down chambers, and symmetric left and right chambers around the tongue; and

a second operational state when the plug is oppositely inserted into the connection slot with the at least one row of connection terminals of the plug facing the first surface of the tongue, the at least one row of connection terminals of the plug are electrically connected to the at least one row of first contacts, and the tongue is disposed within the connection slot, wherein the connection slot is symmetric with symmetric up and down chambers, and symmetric left and right chambers around the tongue.

131. A socket structure with duplex electrical connection, the socket structure comprising:

a plastic base;

a connection slot, which is disposed in front of the plastic base and configured to be connected to a plug having at least one row of connection terminals;

a tongue, which has a top side with a first surface with grooves, and bottom side with a second surface with grooves, the second surface disposed opposite the first surface, the tongue being disposed on one end of the

plastic base and within the connection slot, such that chambers of the connection slot on two sides of the tongue allow the plug to be normally and oppositely inserted and positioned into the connection slot;

at least one row of first contacts separately arranged on the first surface of the tongue, wherein each of the first contacts is electrically connected to a first pin extending out of the plastic base; and

at least one row of second contacts separately arranged on the second surface of the tongue, wherein:

each of the second contacts is electrically connected to a second pin extending out of the plastic base;

the socket structure is operative to simultaneously electrically connect on the top and the bottom side of the tongue;

the at least one row of first contacts has a functional reverse mirror configuration relative to the at least one row of second contacts, and the socket structure is thereby configured such that:

when the plug is normally inserted into the connection slot with the at least one row of connection terminals of the plug facing the second surface of the tongue, the at least one row of connection terminals of the plug are electrically connected to the at least one row of second contacts; and

when the plug is oppositely inserted into the connection slot with the at least one row of connection terminals of the plug facing the first surface of the tongue, the at least one row of connection terminals of the plug are electrically connected to the at least one row of first contacts.

132. A socket structure with duplex electrical connection, the socket structure comprising:

a plastic base;

a connection slot, which is disposed in front of the plastic base and configured to be connected to a plug having at least one row of connection terminals;

a tongue, which has a top side with a first surface with grooves, and bottom side with a second surface with grooves, the second surface disposed opposite the first surface, the tongue being disposed on one end of the plastic base and within the connection slot, such that chambers of the connection slot on two sides of the tongue allow the plug to be normally and oppositely inserted and positioned into the connection slot;

at least one row of first contacts separately arranged on the first surface of the tongue, wherein each of the first contacts is electrically connected to a first pin extending out of the plastic base; and

at least one row of second contacts separately arranged on the second surface of the tongue, wherein:

each of the second contacts is electrically connected to a second pin extending out of the plastic base;

the socket structure is operative to simultaneously electrically connect on the top and the bottom side of the tongue;

the at least one row of first contacts has a functional reverse mirror configuration relative to the at least one row of second contacts, and the socket structure is thereby configured for reversable connection such that:

when the plug is normally inserted into the connection slot with the at least one row of connection terminals of the plug facing the second surface of the tongue, the at least one row of connection terminals of the plug are electrically connected to the at least one row of second contacts; and

when the plug is oppositely inserted into the connection slot with the at least one row of connection terminals of the plug facing the first surface of the tongue, the at least one row of connection terminals of the plug are electrically connected to the at least one row of first contacts.

133. A socket structure with duplex electrical connection, the socket structure comprising:

a plastic base;

a connection slot, which is disposed in front of the plastic base and configured to be connected to a plug having at least one row of connection terminals;

a tongue, which has a first surface with recesses, and a second surface with recesses, the second surface disposed opposite the first surface, the tongue being disposed on one end of the plastic base and within the connection slot, such that chambers of the connection slot on two sides of the tongue allow the plug to be normally and oppositely inserted and positioned into the connection slot;

at least one row of first contacts separately arranged on the first surface of the tongue, wherein each of the first contacts is electrically connected to a respective first pin extending out of the plastic base; and

at least one row of second contacts separately arranged on the second surface of the tongue, wherein:

each of the second contacts is electrically connected to a respective second pin extending out of the plastic base;

the socket structure is operative to simultaneously electrically connect via the first and second contacts;

some of the at least one row of first contacts has a functional reverse mirror configuration relative to some of the at least one row of second contacts, and the socket structure is thereby configured for two operational states:

a first operational state when the plug is normally inserted into the connection slot with the at least one row of connection terminals of the plug facing the second surface of the tongue, the at least one row of connection terminals of the plug are electrically connected to the at least one row of second contacts and the tongue is disposed within the connection slot, wherein the connection slot is symmetric with symmetric up and down chambers, and symmetric left and right chambers around the tongue; and

a second operational state when the plug is oppositely inserted into the connection slot with the at least one row of connection terminals of the plug facing the first surface of the tongue, the at least one row of connection terminals of the plug are electrically connected to the at least one row of first contacts, and the tongue is disposed within the connection slot, wherein the connection slot is symmetric with symmetric up and down chambers, and symmetric left and right chambers around the tongue.

134. A socket structure with duplex electrical connection, the socket structure comprising:

a plastic base;

a connection slot, which is disposed in front of the plastic base and configured to be connected to a plug having at least one row of connection terminals;

a tongue, which has a top side with a first surface with grooves, and bottom side with a second surface with grooves, the second surface disposed opposite the first surface, the tongue being disposed on one end of the plastic base and within the connection slot, such that chambers of the connection slot on two sides of the

45

tongue allow the plug to be normally and oppositely inserted and positioned into the connection slot;
at least one row of first contacts separately arranged on the first surface of the tongue, wherein each of the first contacts is electrically connected to a first pin extending out of the plastic base; and
at least one row of second contacts separately arranged on the second surface of the tongue, wherein:
each of the second contacts is electrically connected to a second pin extending out of the plastic base;
the socket structure is operative to simultaneously electrically connect on the top and the bottom side of the tongue;
at least some of the at least one row of first contacts has a functional reverse mirror configuration relative to at least some of the at least one row of second contacts, and the socket structure is thereby configured such that:
when the plug is normally inserted into the connection slot with the at least one row of connection terminals of the plug facing the second surface of the tongue, the at least one row of connection terminals of the plug are electrically connected to the at least one row of second contacts; and
when the plug is oppositely inserted into the connection slot with the at least one row of connection terminals of the plug facing the first surface of the tongue, the at least one row of connection terminals of the plug are electrically connected to the at least one row of first contacts.
 135. A socket structure with duplex electrical connection, the socket structure comprising:
a plastic base;
a connection slot, which is disposed in front of the plastic base and configured to be connected to a plug having at least one row of connection terminals;
a tongue, which has a top side with a first surface with grooves, and bottom side with a second surface with

46

grooves, the second surface disposed opposite the first surface, the tongue being disposed on one end of the plastic base and within the connection slot, such that chambers of the connection slot on two sides of the tongue allow the plug to be normally and oppositely inserted and positioned into the connection slot;
at least one row of first contacts separately arranged on the first surface of the tongue, wherein each of the first contacts is electrically connected to a respective first pin extending out of the plastic base; and
at least one row of second contacts separately arranged on the second surface of the tongue, wherein:
each of the second contacts is electrically connected to a respective second pin extending out of the plastic base;
the socket structure is operative to simultaneously electrically connect on the top and the bottom side of the tongue;
a portion of the at least one row of first contacts has a reverse mirror configuration relative to a portion of the at least one row of second contacts, and the socket structure is thereby configured for reversible connection such that:
when the plug is normally inserted into the connection slot with the at least one row of connection terminals of the plug facing the second surface of the tongue, the at least one row of connection terminals of the plug are electrically connected to the at least one row of second contacts; and
when the plug is oppositely inserted into the connection slot with the at least one row of connection terminals of the plug facing the first surface of the tongue, the at least one row of connection terminals of the plug are electrically connected to the at least one row of first contacts.

* * * * *