



(22) Date de dépôt/Filing Date: 2008/11/12  
 (41) Mise à la disp. pub./Open to Public Insp.: 2009/05/13  
 (45) Date de délivrance/Issue Date: 2016/01/05  
 (30) Priorité/Priority: 2007/11/13 (EP07291356.9)

(51) Cl.Int./Int.Cl. *A47K 10/32* (2006.01),  
*A47K 10/36* (2006.01), *B65H 35/00* (2006.01)

(72) Inventeurs/Inventors:  
 CATTACIN, GILLES, FR;  
 POMMIER, NICOLAS, FR;  
 LINSTEDT, BRIAN K., US;  
 STARK, SALLY ANN, US;  
 ROTHWELL, TIMOTHY C., US;  
 STONIS, LUKE C., US

(73) Propriétaire/Owner:  
 GEORGIA-PACIFIC CONSUMER PRODUCTS LP, US

(74) Agent: NORTON ROSE FULBRIGHT CANADA  
 LLP/S.E.N.C.R.L., S.R.L.

(54) Titre : SYSTEME PERMETTANT D'AMELIORER LA RESISTANCE A L'EAU D'UN DISTRIBUTEUR DE ROULEAUX DE PAPIER

(54) Title: SYSTEM FOR ENHANCING WATER RESISTANCE OF A ROLL DISPENSER

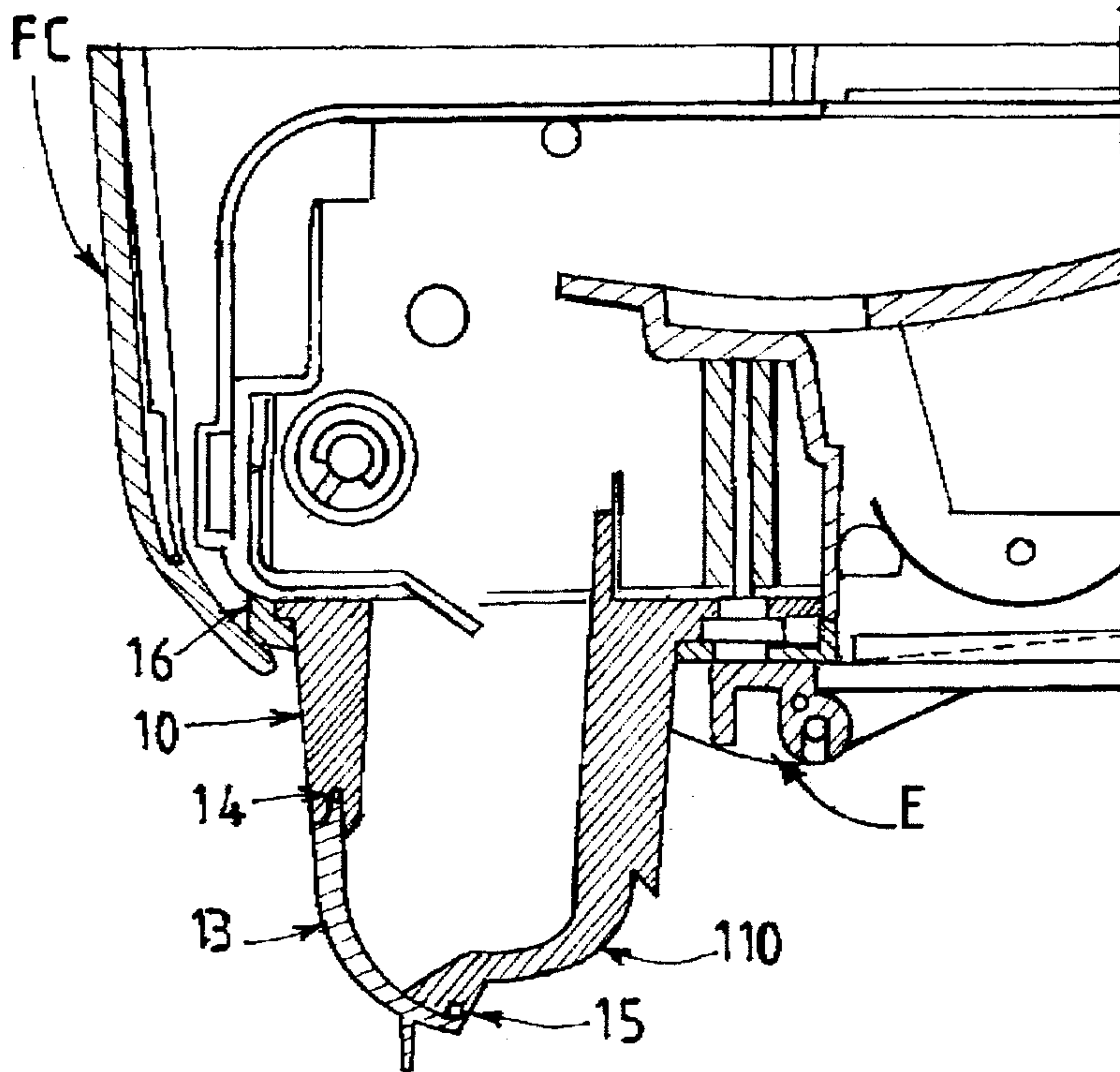

(57) Abrégé/Abstract:

A system for enhancing the water resistance of a roll dispenser, to be attached to the dispenser opening, said system comprising:  
 - a means (10) for housing the paper, attached to the periphery of the dispenser opening; - a repositionable chute door (13) movable between an open and a closed position; - at least a door seal (14, 15) between the housing means and the chute door.

## ABSTRACT

A system for enhancing the water resistance of a roll dispenser, to be attached to the dispenser opening , said system comprising :

- a means (10) for housing the paper, attached to the periphery of the dispenser opening ;

- a repositionable chute door (13) movable between an open and a closed position ;

- at least a door seal (14, 15) between the housing means and the chute door.

Figure 5

## SYSTEM FOR ENHANCING WATER RESISTANCE OF A ROLL DISPENSER

This invention relates to the field of dispenser for roll web product, such  
5 as roll towel product. In particular it relates to an improvement for such  
dispensers, which render them resistant to water penetration during cleaning  
procedures.

Roll dispensers are often provided in public or commercial facilities,  
and subjected to cleaning by a pressure spray of water or other more  
10 aggressive component (detergent, cleaning solution).

Figure 1 shows this kind of washing which can take place in industrial  
food preparation facilities, public washrooms, outside wet environments ...  
where strong spraying occurs against the dispenser.

Moreover in such circumstances, washing can occur one or more times  
15 per day. It is often aimed to prevent the inadvertent spread of bacteria and/or  
diseases.

During the washing, liquid may penetrate and leak into the dispensers,  
resulting in products placed in said dispenser to become wet.

If the product is a roll of paper towel, it is wasted ; jamming can  
20 occur ... the roll has to be removed and disposed by the maintenance people.  
This is costly.

Furthermore components in the dispenser may be damaged by a dried  
cleaning solution which has leaked inside ... The dispenser is less likely to  
operate properly.

25 Also water and/or liquid cleaning solution which leaks inside the  
dispenser may carry bacteria or other pathogens as well.

Due to these problems, there is a need for an easy way to enhance  
water or liquid resistance to a standard dispenser.

To overcome said main problems, many workers have resorted to  
30 removing the standard dispenser before each washdown and remounting it to  
the wall thereafter.

But this is a strong constraint.

Some technical solutions are known : EP 0 967 908 B1 discloses a  
water-resistant roll web dispenser provided with a perimeter groove on the  
35 front housing portion, which cooperates with a perimeter lip on the back  
housing portions to form together a labyrinthine seal structure when front  
housing portion is closed on said back housing portion.

This solution allows both portions to suitably seal together. As far as  
the dispensing slot is concerned, this prior document relates to a deflection

shield to deflect liquid spray from virtually any spray angle, except a vertical spray directly into the dispensing slot.

Thus this solution does not preclude neither vertical spray nor any wet environment (atmosphere) that can wet and damage the inside of the dispenser.

To overcome the problem of washdown operation and wet environments, specific solutions are also known :

For example US 4,662,664 deals with a lock for a paper towel dispenser, made of molded plastic material.

US 5,273,184 discloses a dispenser with a lower and central nozzle protected with an external shield to protect the nozzle from liquid directed towards it. However, an access opening is provided and remains open even if washdown. It may thus happen that a vertical spray enters through said opening and damages the interior of the dispenser.

EP 1 230 886 discloses a solution where ribs in the lower part of the dispenser hold the dispensing towel off of the wet surfaces it would otherwise contact . This is a low cost and non secure solution to washdown .

The present invention overcomes the problem of washdown and wet environments of dispenser for roll web product, by eliminating liquid penetration into said dispenser in a very simple and reliable way.

In other words, the invention is a system adapted for use with a dispenser to render said dispenser fully and securely water resistant.

As used herein :

- the term "dispenser opening" is the opening of a standard dispenser ; it is placed in the bottom face of the dispenser when this latter is fixed on a vertical wall ;

- the term "chute door" is the element that closes the system when a washdown occurs ;

- the term "housing means" refers to an element attached to the dispenser bottom face, which contains and guides the paper out of the dispenser opening ;

- the term "paper" means a sheet material such as paper tissue, paper toweling, toilet paper, label rolls ..., which exhibits a relatively flat planar configuration and is flexible to permit folding, rolling, stacking and the like.

In response to the difficulties and problems discussed above, the invention relates to a system for enhancing the water resistance of a roll dispenser, to be attached to the dispenser opening ;

said system comprising :

- a means for housing the paper, attached to the periphery of the dispenser opening ;

- a repositionable chute door movable between an open and a closed position ;

5 - a paper chute seal between the housing means and the dispenser opening ;

- at least a door seal between the housing means and the chute door.

Such a system is releasably coupled to a standard roll dispenser.

Preferably, the chute door is rotatable.

10 More precisely, said housing means comprises :

- a semi cylindrical portion prolonged by a parallelepipedic over portion ;

15 - two flanges provided with lock detents cooperating with protrusions of the chute door ; and with an outer protrusion used as a rotation axle for the chute door.

Furthermore, the flanges are provided with grooves between lock detents, to guide the chute door between the open and the closed position.

Moreover, the chute housing is provided with an outer recess for sliding (placing) said chute door at the open position.

20 Advantageously, the chute door is provided with a holding means, for manually displacing it between said open and said closed positions.

According to another feature of the invention, the chute door cooperates with a first elongated door seal when in open position, and with both said first and a second elongated door seal when in closed position.

25 This cooperation makes the system quite reliable as far as the sealing is concerned, whatever the outside conditions are.

Preferably, the door seals are made of foamed rubber. Other convenient material can be used.

30 Conveniently, the door seals are housed in elongated outer grooves of the chute housing.

Furthermore, a paper chute seal is provided, and compressed between the under peripheric surface of the system and the upper surface of the dispenser opening and/or the upper surface of the front cover.

35 Others details, advantages and characteristics of the invention will now appear from the following detailed description, with reference to the following drawings :

- figure 2A is a perspective view of a dispenser with a system according to the invention in the normal operating position ;

- figure 2B is a perspective view of a dispenser with a system according to the invention in a washdown position ;

- figure 3A is a side elevation view of the system in the normal operating position ;

5 - figure 3B is a side elevation view of the system in a washdown position ;

- figure 4 is an exploded view of a preferred embodiment of the invention; and

- figure 5 is a section of a system according to the invention, as  
10 attached to a standard dispenser.

Figures 2A and 2B show a known dispenser D to which is attached a system S according to the invention.

As visible, figure 2A relates to the system S in a normal operating position i.e. a dispensing position ; whereas figure 2B deals with the  
15 washdown position when the system S is fully closed and sealed to the dispenser D.

The system S can have various shapes. It is necessary sealingly attached to the usual opening of the dispenser which is currently disposed under the dispenser. Other layouts of the opening are within the scope of the  
20 invention.

On figures 3A and 3B as well as on figure 4, one can see the different means (pieces) which constitute an embodiment according to the invention.

More precisely, there is a means 10 for housing the paper. It is attached to the periphery of the dispenser opening (not referenced) by any  
25 means known per se.

According to a preferred embodiment, the housing means 10 has a semi cylindrical portion 11 prolonged by a parallelepipedic (8) over portion 12 directly attached to the dispenser opening. The portion 12 is necessary if the system is used with an electronic dispenser which is able to dispense sheets  
30 of paper as soon as it detects the proximity of a hand for example. In such a case, at least a sheet can be dispensed when the system is in a closed (washdown) position, and the sheet dispensed correctly, without any jam.

The system enables at least a sheet to be dispensed and temporary stored in the system when in a closed position.

35 Besides, according to an embodiment , a rotatable chute door 13 is provided, cooperating with the housing means 10, and movable between an open and a closed position.

The open position is shown on figure 3A whereas the closed position is the one disclosed on figure 3B.

Globally, the chute door 13 comprises a portion of cylinder 130 and two lateral semi circular flanges 131, 132.

The chute door 13 is provided with a holding means 133 for manually displacing it between the open and the closed positions. It rotates around an axle determined by protuberances in the flange of the housing 10. The protuberances cooperates with respective holes 134, 135 in each flange 131, 132 of the chute door 13.

Each flange 131, 132 of the chute door 13 is further provided with a protrusion (not referenced) cooperating with a semi circular groove of the flange of the housing means. Additionally, each semi circular groove ends through a hole for positioning a protrusion of the chute door either in the open or in the closed position.

Theses means respectively guide and position the chute door 13 with respect of the chute housing 10. Any means which fulfil these functions are within the scope of the invention.

According to another feature, the semi-cylindrical portion 11 of the housing means 10 is provided with an outer recess 110 for positioning said chute door at the open position. The recess 110 allows an outer compact shape of the system, when the chute door is in the open position as well as when it is in the closed position.

At least a door seal is provided between the housing means 10 and the chute door 13.

This seal 14, further called "door seal-upper" is aimed to limit the direct water infiltrations inside the chute housing 10. It can be made of foamed rubber, and it has for example a square or circular cross section. It is preferably housed in a groove made in the chute housing, and it runs parallelly to the upper edge of the chute door 13.

Another seal 15 can be provided at the lowest part of the chute housing 10, between said chute housing 10 and the chute door 13. It is aimed to avoid water from the wall behind the system to enter inside the system when the chute door is in the closed position.

The second seal 15 can be made of foamed rubber, with a square or circular cross section. It can be housed in a groove, or not.

According to another embodiment, the above described seals can be over molded :

In this respect, the main piece i.e. the chute door for example is, in a first step, molded through injection. It is provided with small "linking" holes. Then it is transferred to a second mold where the seal is added , positioned

and linked thanks to introduction of some of its portions into said "linking" holes of the molded chute door.

Another technical process is the "bi injection" wherein the molding press is provided with two separate nozzles each injecting either the material of the door (polypropylen for example) or the material of the seal (foam for example).

These are different processes for manufacturing either on a single equipment or on different equipments : the chute door, the housing means and their associated seals.

Other seals can be provided, between the system and elements in direct contact with it : for example between the front cover of the dispenser and the system ; and between the lower back part of the dispenser and the system.

In particular, a paper chute seal 16 as fully illustrated on figure 4, can be provided in this respect.

Figure 5 illustrates an example of connection between a system according to the invention and a known dispenser.

The system is placed at the lowest part of the dispenser ; it is an additional means that encloses the usual opening. The system rests on existing edges E of the opening and on the front cover FC of the dispenser. It is attached to the dispenser by any means known per se.

As seen on figure 5, the system S according to the invention is tightly fixed under the existing dispenser, and it forms a closed and sealed box when the chute door 13 is closed. Furthermore it is a safe and seal space for storing any sheet that could be dispensed when the chute door 13 is closed.

The above advantages and features render the invention very appropriate for washdowns of dispensers.

## CLAIMS

1. A sheet product dispenser comprising:
  - a housing comprising a dispenser opening for dispensing sheet product; and
  - a water resistance means attached to a periphery of the dispenser opening, the water resistance means comprising:
    - a means for housing the sheet product,
    - a repositionable chute door movable between an open and a closed position,
    - a chute seal between the housing means and the dispenser opening, and
    - at least one door seal between the housing means and the chute door;wherein the housing means comprises:
  - a semi cylindrical portion prolonged by a parallelepipedic over portion,
  - two flanges provided with lock detents cooperating with protrusions of the chute door, and
  - with an outer protrusion used as a rotation axle for the chute door.
2. The sheet product dispenser according to claim 1, wherein the flanges are further provided with grooves between lock detents, to guide the chute door between the open and the closed position.
3. The sheet product dispenser according to claim 1 or 2, wherein the chute housing is provided with an outer recess for positioning the chute door at the open position.
4. The sheet product dispenser according to any one of claims 1 to 3, wherein the chute door is rotatable.
5. The sheet product dispenser according to any one of claims 1 to 4, wherein said chute door is provided with a holding means for manually displacing it between said open and said closed positions.
6. The sheet product dispenser according to any one of claims 1 to 5, wherein the at least one door seal includes first and second elongated door

seals, said chute door cooperating with said first elongated door seal when in the open position, and with both said first and second elongated door seals when in the closed position.

7. The sheet product dispenser according to any one of claims 1 to 6, wherein the at least one door seal is made of an elastomeric material.

8. The sheet product dispenser according to claim 7, wherein the elastomeric material is foamed rubber.

9. The sheet product dispenser according to any one of claims 1 to 8, wherein each of the at least one door seals is housed in an elongated outer groove of the chute housing.

10. The sheet product dispenser according to any one of claims 1 to 9, wherein the paper chute seal is compressed between an under peripheric surface of the system and an upper surface of the dispenser opening.

11. The sheet product dispenser according to any one of claims 1 to 9, wherein the paper chute seal is compressed between an under peripheric surface of the system and an upper surface of a front cover.

12. A sheet product dispenser comprising:

a housing comprising a dispenser opening for dispensing sheet product disposed within the housing; and

a water resistance apparatus attached to the housing at a periphery of the dispenser opening, the water resistance apparatus comprising:

a body portion comprising a body portion opening, the body portion being disposed for guiding the sheet product dispensed out of the dispenser opening through the body portion opening,

a repositionable chute door movable between an open and a closed position relative to the body portion opening,

a first seal disposed between the body portion and the housing,

and

at least a second seal disposed between the body portion and the chute door;

wherein the body portion comprises:

two flanges provided with lock features cooperating with mating lock features of the chute door, and provided with a pivot feature used as a rotation axle for the chute door.

13. The sheet product dispenser according to claim 12, wherein the two flanges each further comprise grooves extending between the respective lock features to guide the chute door between the open and the closed position.

14. The sheet product dispenser according to claim 12 or 13, wherein the body portion further comprises an outer recess for positioning the chute door at the open position.

15. A water resistance apparatus adapted for attachment to a housing of a sheet product dispenser at a periphery of a dispenser opening of the housing, the sheet product dispenser being adapted for holding and dispensing sheet product disposed within the housing, the water resistance apparatus comprising:

a body portion comprising a body portion opening, the body portion being disposed for guiding the sheet product dispensed out of the dispenser opening through the body portion opening,

a repositionable chute door movable between an open and a closed position relative to the body portion opening,

a first seal disposed between the body portion and the housing, and

at least a second seal disposed between the body portion and the chute door;

wherein the body portion comprises:

two flanges provided with lock features cooperating with mating lock features of the chute door, and provided with a pivot feature used as a rotation axle for the chute door.

16. The water resistance apparatus according to claim 15, wherein the two flanges each further comprise grooves extending between the respective lock features to guide the chute door between the open and the closed position.

17. The water resistance apparatus according to claim 15 or 16, wherein the body portion further comprises an outer recess for positioning the chute door at the open position.

1/4

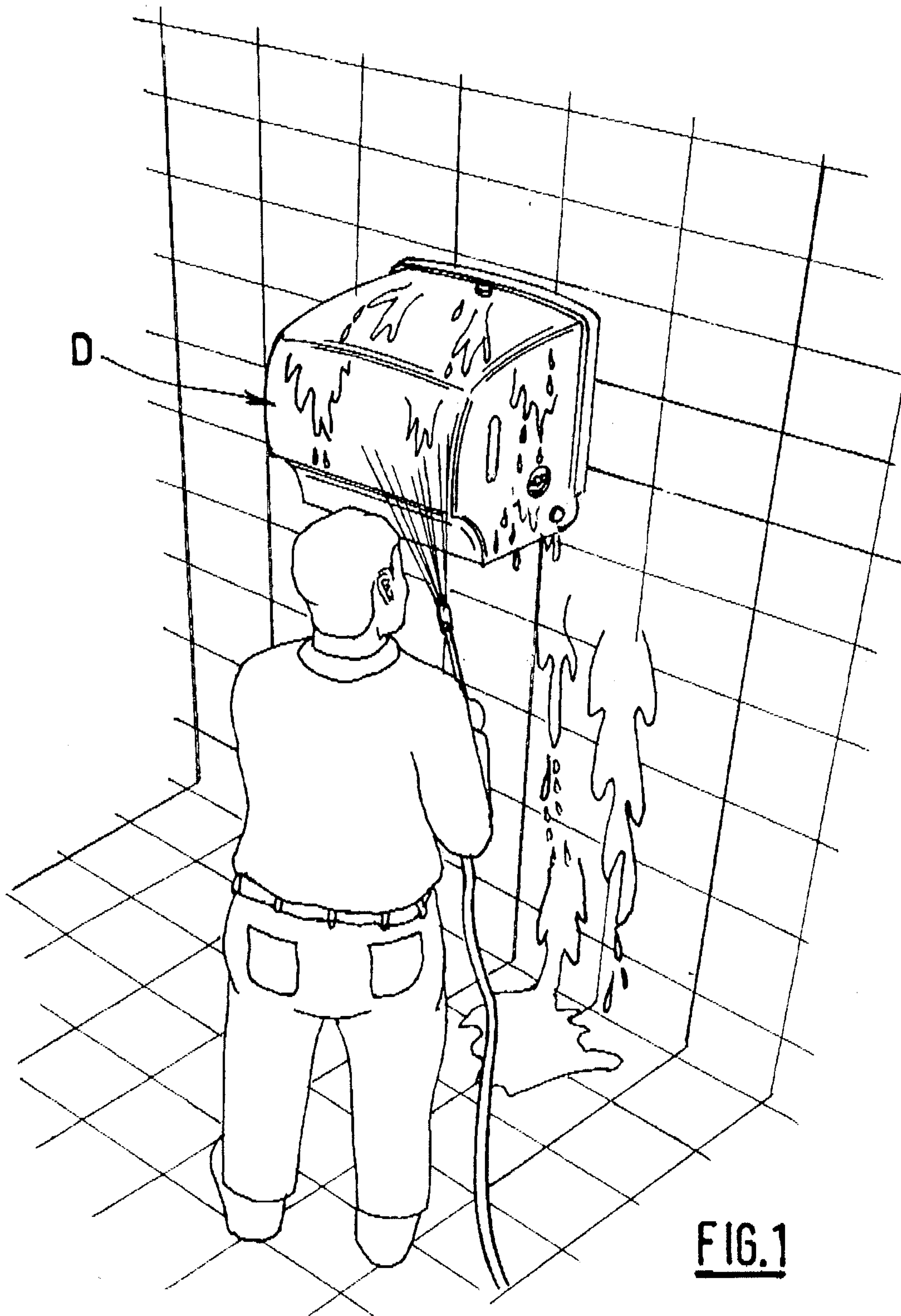

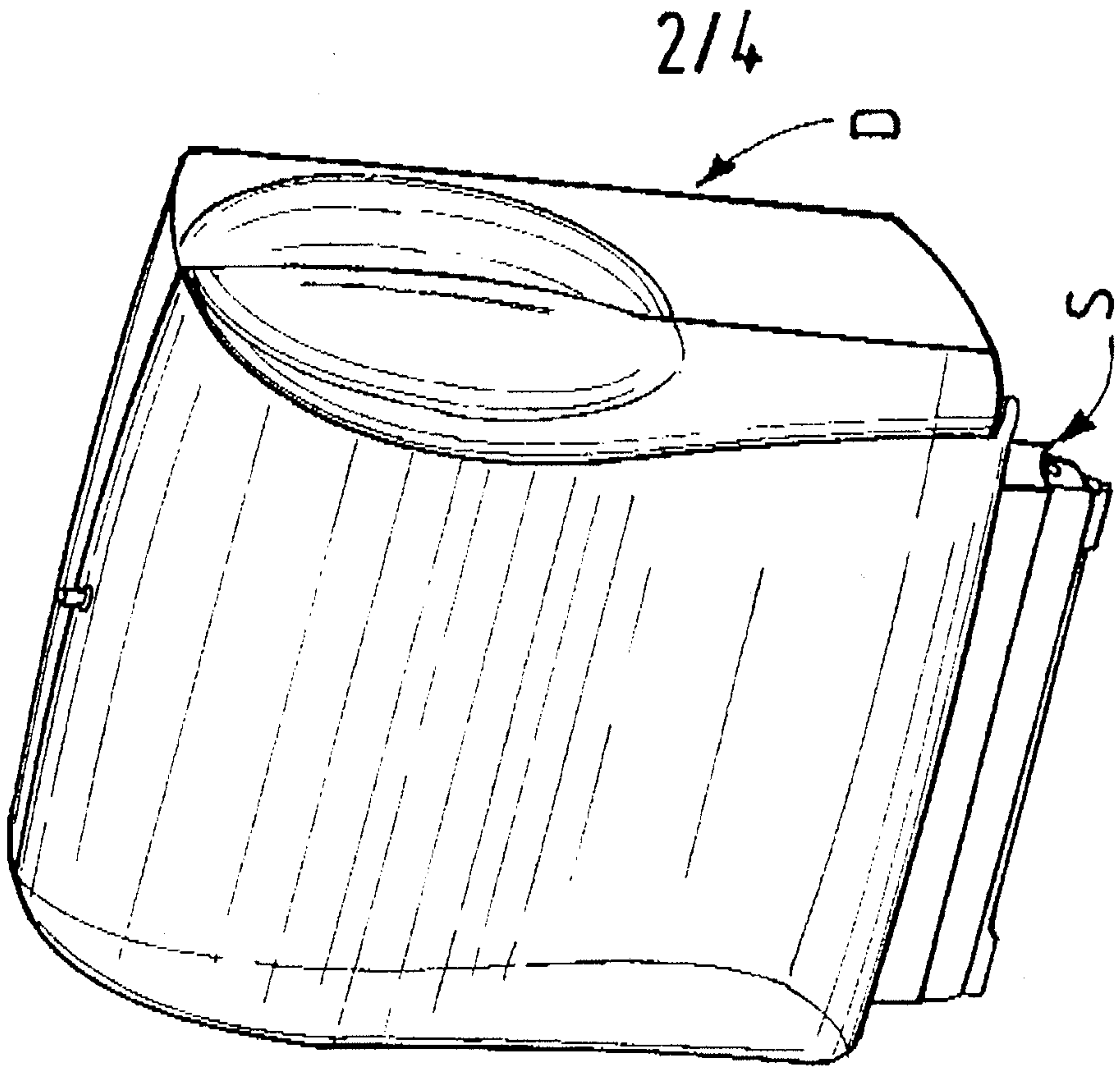

FIG. 2B

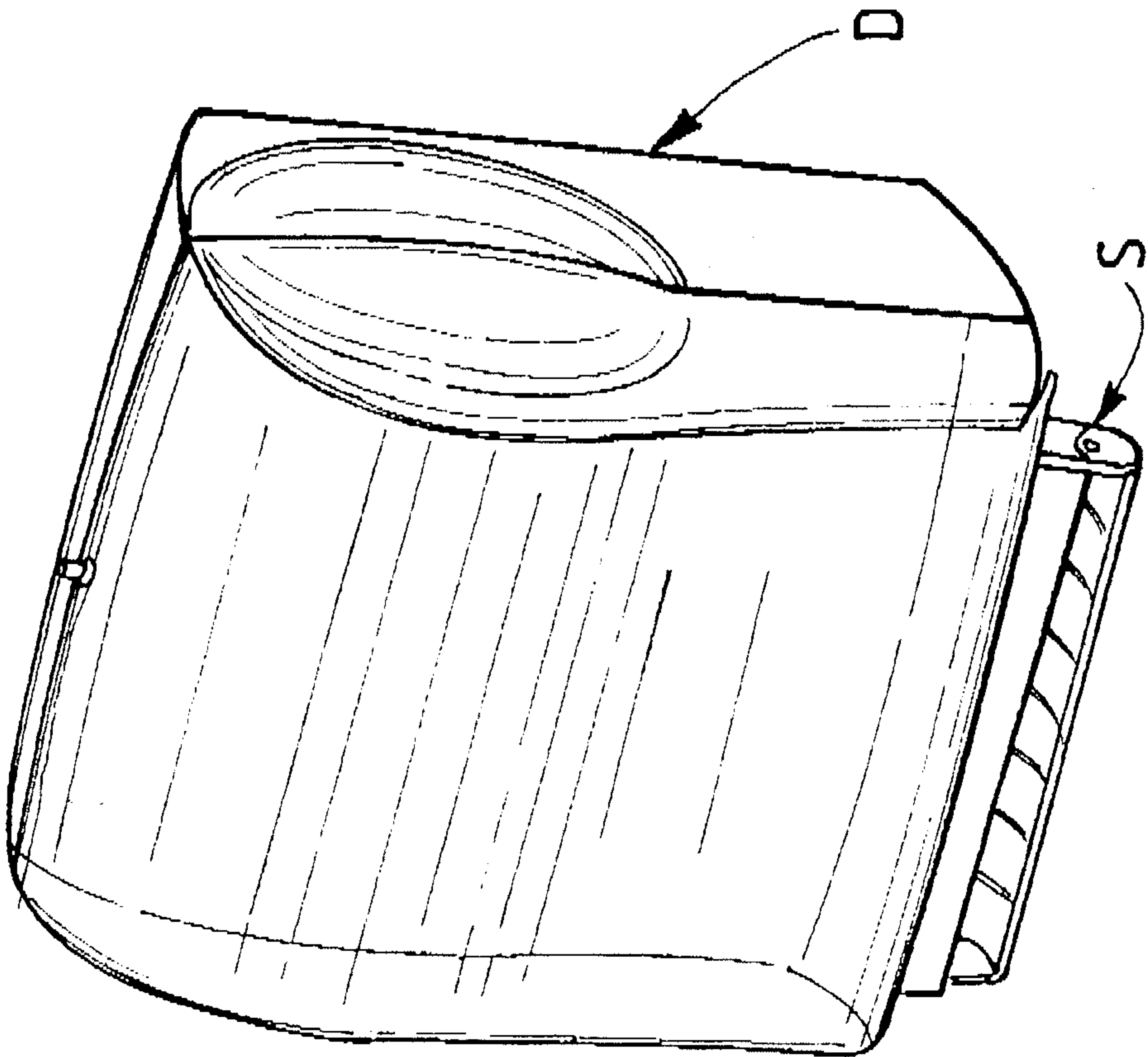

FIG. 2A

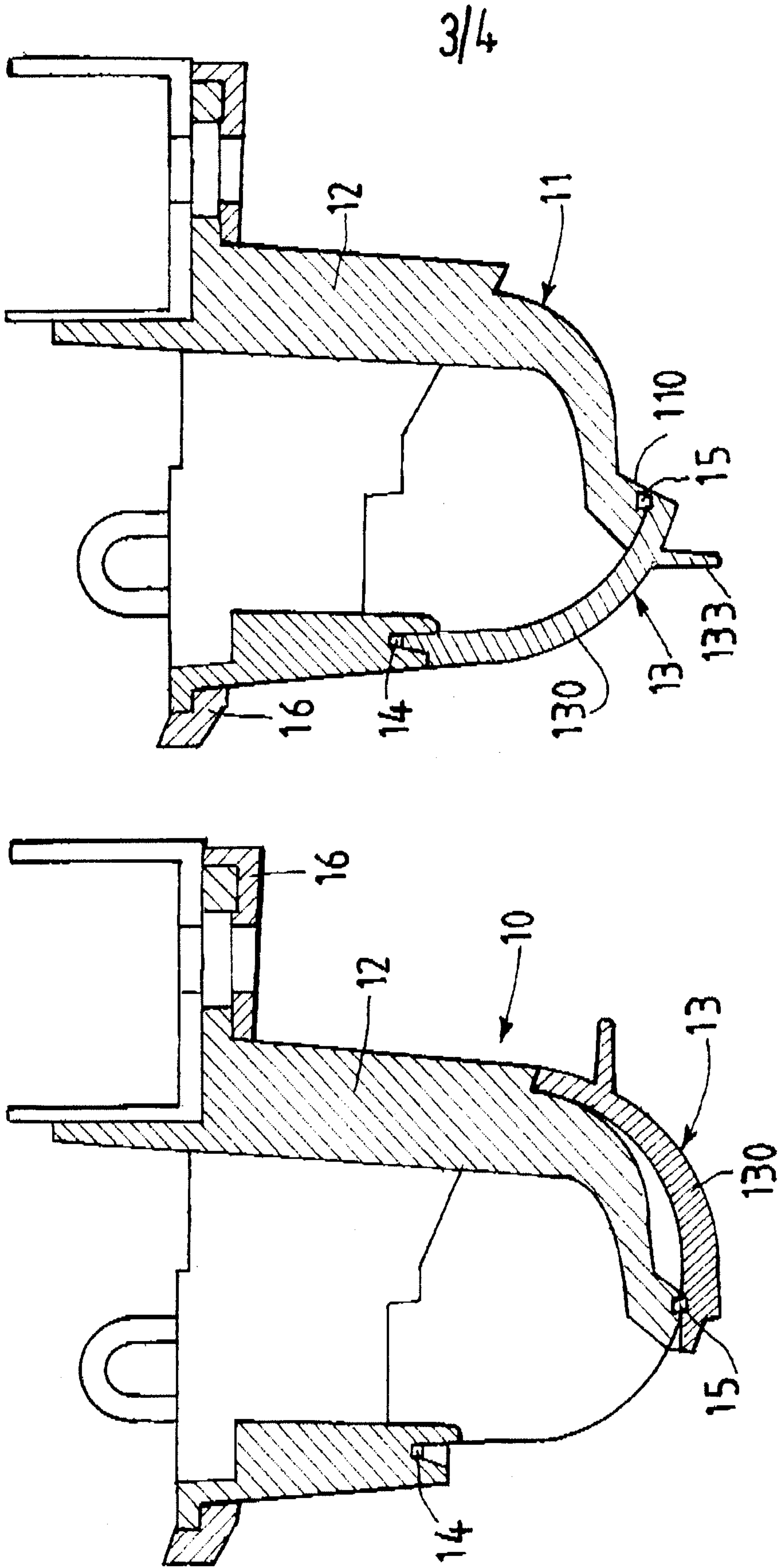

FIG. 3B

FIG. 3A

