

J. W. CROOKS.
 ACCENTING DEVICE FOR PNEUMATIC PIANO PLAYER ACTIONS.
 APPLICATION FILED MAR. 31, 1910.

1,000,377.

Patented Aug. 15, 1911.

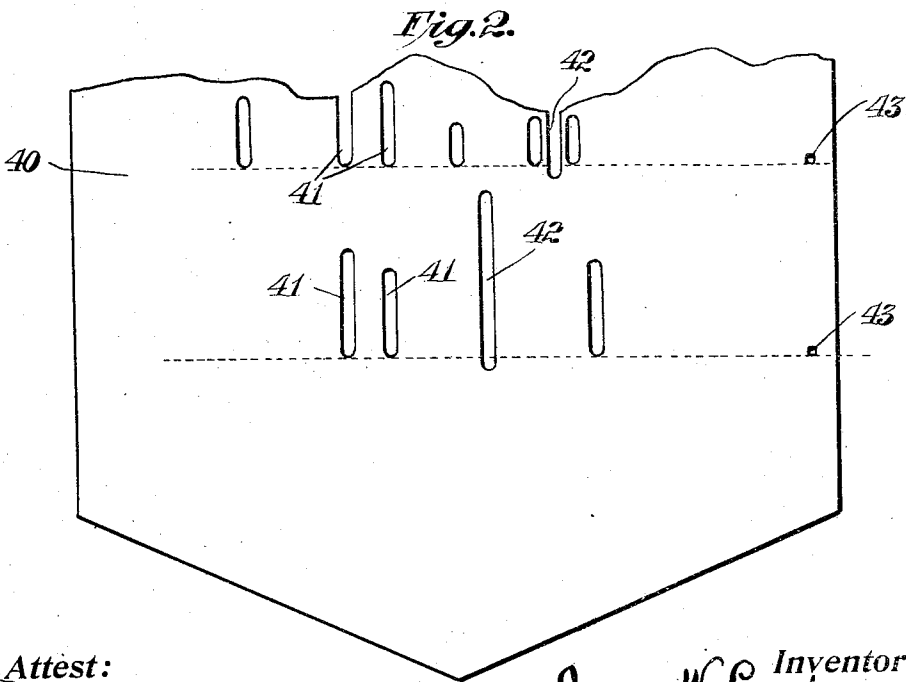
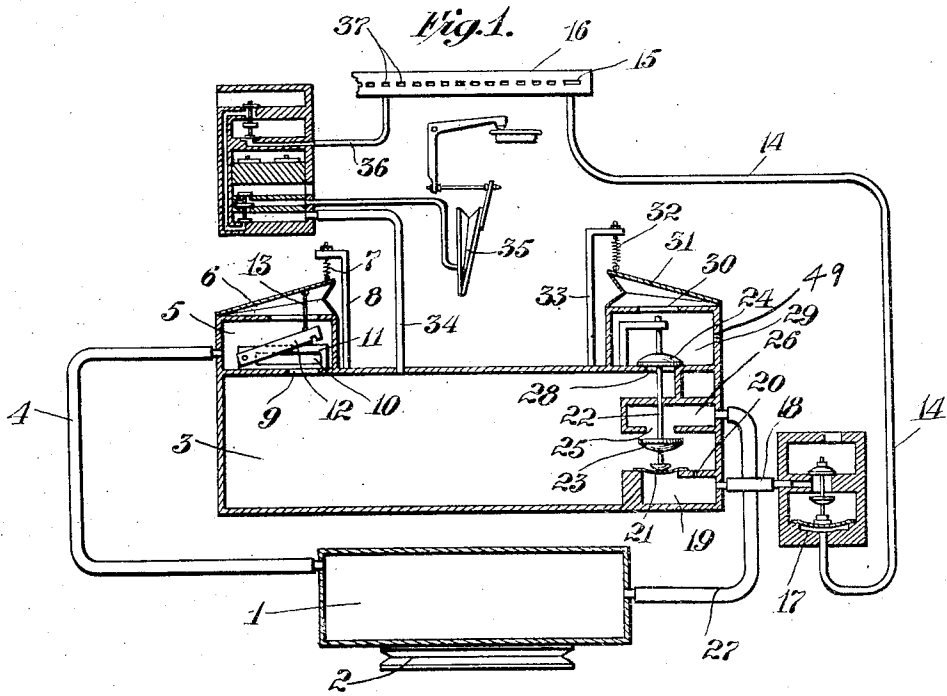

Attest:
Raymond Richardson

Inventor:
James W. Crooks
 by *Robert T. Perry* Atty

UNITED STATES PATENT OFFICE.

JAMES W. CROOKS, OF MOUNT VERNON, NEW YORK.

ACCENTING DEVICE FOR PNEUMATIC-PIANO-PLAYER ACTIONS.

1,000,377.

Specification of Letters Patent. Patented Aug. 15, 1911.

Application filed March 31, 1910. Serial No. 552,489.

To all whom it may concern:

Be it known that I, JAMES W. CROOKS, a citizen of the United States, and resident of Mount Vernon, in the county of Westchester and State of New York, have invented certain new and useful Improvements in Accenting Devices for Pneumatic-Piano-Player Actions, of which the following is a specification.

The object of my invention is to provide a new and improved accenting device for pneumatic piano player actions to be used in conjunction with perforated note sheets, having supplemental perforations, for the purpose of emphasizing or giving expression to the theme or melody notes while playing the accompaniment notes normally or softly, which device is simple in construction, compact, reliable and effective in use and action.

In the accompanying drawings in which like letters of reference indicate like parts in all the figures: Figure 1 is a diagrammatic view of my improved accenting device for pneumatic piano player actions. Fig. 2 is a face view of the perforated music sheet to be used in conjunction therewith.

The high pressure wind chest 1 is exhausted by means of the exhaust-bellows 2 of conventional construction and this high pressure wind chest is connected with the action wind chest 3 by two separate connections which will now be described.

A duct or passage 4 leads from the high pressure wind chest 1 to a chamber 5 in communication with the collapsible bellows or pneumatic 6 which is connected by a spring 7 with a suitable support 8. A port 9 leads from the chamber 5 to the action wind chest 3 and this port terminates within the chamber 5 in a slot 10 in the side of a block 11 to which is pivoted a knife valve 12 connected by a link or other suitable connection 13 with the movable board of the bellows 6, so that as the bellows is collapsed the knife valve closes, to a greater or less extent, the slot 10, thereby decreasing the effective opening establishing communication between the action chest 3 and the conduit 4 in accordance with the position of this valve.

A tube 14 leads from the supplemental duct or opening 15 in the tracker board 16 to a primary pneumatic valve 17 of conventional construction from which the tube 18 leads to a chamber 19 having a bleed hole 20 and closed at its top by a diaphragm 21

upon which rests the valve stem 22 carrying two valves 23 and 24. The valve 23 serves to close the opening 25 in the bottom of the chamber 26 connected by a conduit 27 with the high pressure wind chest 1. The valve 24 when lowered serves to close the port 28 in the bottom of the chamber 29 connected by a port 30 with the bellows or expandible device 31 which is held expanded by the spring 32 on the standard 33.

The music sheet 40 shown in Fig. 2 is provided with a series of slots for the notes representing the accompaniment and the melody, the accompaniment note slots being marked 41 and the melody note slots 42. It will be observed that the front ends of the melody note slots 42 are slightly ahead of the front ends of the accompaniment note slots 41. By front ends I mean those ends of the slots that first reach the tracker. It will also be observed that at the side edge of the note sheet there is a row of supplemental apertures 43 which are in line with the front ends of the accompaniment note slots 41 and therefore slightly to the rear of the front end of the melody note slots 42. The action wind chest 3 is connected by ducts 34 with the striker pneumatics 35 and the primary and secondary valves of the same are connected by ducts 36 with the note openings or ducts 37 of the tracker in the conventional manner. Normally the valve 23 is lowered and there is thus a direct connection between the action wind chest 3 and the high wind chest 1 and there will be high tension wind in this action wind chest 3.

In a transverse row of note slots the front end of the slot 42 for the note to be accented reaches the ducts in the tracker board ahead of, or before the front ends of the slots for the accompaniment notes or notes not to be accented and before the corresponding side aperture 43 in the note sheet reaches the supplemental duct 15 thus it follows that the note slots for the melody will be sounded with full force on high wind as there is at the time high tension in the action wind chest 3. Instantly thereafter the corresponding side aperture 43 registers with the supplemental duct 15 of the tracker board, admitting atmospheric air to the primary valve 17 through which in turn atmospheric air is admitted through the duct 18 into the chamber 19 and the valve stem 22 is raised and the valve 23 is seated to close the port 25 thereby

closing the direct communication between the high wind chest 1 and the action wind chest 3. At the same time the valve 24 is lifted off this seat and opens the port 28 thus bringing the bellows 31 into communication with the chest 3 in which latter high tension exists and this high tension of course instantly collapses the bellows 31 against the tension of the spring 32 and this necessarily causes a material reduction of tension of air in the chest 3 as the energy in the high tension air in the chest 3 has been spent to a great extent in collapsing the bellows 31, and thus the bellows 31 is a tension relieving chamber or air tension reducer, the purpose being to promptly aid the regulator 6 in bringing the previous condition of high tension in the action chest 3 to the standard regulator tension. At the same time also, the bellows 6 is collapsed by the high wind in the chamber 5 and the knife valve 12 closes the slot 10 to a greater or less extent, thus reducing the effective area of communication between the wind chest 1 and the action wind chest 3 through the duct 4 so that when the slots 41 for the normal notes or accompaniment notes reach their ducts of the tracker board the tension of the wind in the chest 3 has been reduced to such an extent that the accompanying notes are sounded with less force than the melody notes. As soon as the supplemental aperture 43 of the note sheet has passed the supplemental duct 15 of the tracker board the chamber 19 is exhausted through the bleed hole 20 and direct communication is established through the chamber 26 and duct 27 between the high tension wind chest 1 and action wind chest 3 and at the same time the valve 24 is seated and the chamber 29 is filled with atmospheric air through the bleed hole 49, and the spring 32 expands the bellows 31. Also at the same time the spring 7 expands the bellows 6 causing the knife valve 12 to open the slot 10 fully, and so on.

Of course it is evident that the supplemental openings 43 must be provided in the music sheet for each transverse row of note slots in which one or more notes are to be sounded normal. When the single note of the transverse line or all the notes of a transverse line on the music sheet are to be sounded loud there is no need of a supplemental opening 43.

Having described my invention what I claim as new and desire to secure by Letters Patent is:

1. In an automatic piano playing action controlled by a perforated music sheet, the combination with a tracker, a main wind chest and means for exhausting air from the same, of an action wind chest, means connecting the same with the main wind chest, a valve controlling the communication be-

tween the two chests, pneumatic means for operating said valve from the tracker board, a tension relieving chamber communicating with the action chest, means establishing communication between the tension relieving chamber and the atmosphere, and a valve controlling the communication between the tension relieving chamber and the action chest, and means for controlling this valve from the tracker, substantially as set forth.

2. In an automatic piano playing action controlled by a perforated music sheet, the combination with a tracker, a main wind chest and means for exhausting air from the same, of an action wind chest, means connecting the same with the main wind chest, a valve controlling the communication between the two chests, pneumatic means for operating said valve from the tracker board, a tension relieving chamber communicating with the action chest, means establishing communication between the tension relieving chamber and the atmosphere, and a valve controlling the communication between the tension relieving chamber and the action chest connected and operating with the above mentioned valve that controls the communication between the main wind chest and the action wind chest, substantially as set forth.

3. In an automatic piano playing action controlled by a perforated music sheet, the combination with a tracker, a main wind chest and means for exhausting air from the same, of an action wind chest, means connecting the same with the main wind chest, a valve controlling the communication between the two chests, pneumatic means for operating said valve from the tracker board, a tension relieving chamber communicating with the action wind chest, means establishing communication between the tension relieving chamber and the atmosphere, a valve controlling the communication between the tension relieving chamber and the action windchest, a collapsible chamber connected with said tension relieving chamber and a spring connected with said collapsible part, substantially as set forth.

4. In an automatic piano playing action controlled by a perforated music sheet, the combination with a tracker, a main wind chest and means for exhausting air from the same, of an action wind chest, two independent connections between the said two wind chests, an automatic controlling valve controlling one of these communications, a valve controlling the other communication, means operated from the tracker board for actuating the second valve, a tension relieving chamber connected with the action wind chest, means establishing communication between the tension relieving chamber and the atmosphere, a valve for controlling the com-

munication between the main wind chest and the tension relieving chamber and means for operating said valve from the tracker, substantially as set forth.

5 5. In an automatic piano playing action controlled by a perforated music sheet, the combination with a tracker, a main wind chest and means for exhausting air from the same, of an action wind chest, a duct estab-
 10 lishing communication between the two wind chests, a normally open valve controlling the communication between said two wind chests, a tension relieving chamber connected with the action wind chest, means

establishing communication between the 15 tension relieving chamber and the atmosphere, a normally closed valve controlling the communication between the action wind chest and the tension relieving chamber, and means for operating said valves from 20 the tracker board, substantially as set forth.

Signed at New York city in the county of New York and State of New York this 23rd day of March A. D. 1910.

JAMES W. CROOKS.

Witnesses:

E. R. JOHNSON,
 A. W. HUMPHREYS.

Copies of this patent may be obtained for five cents each, by addressing the "Commissioner of Patents, Washington, D. C."