

No. 862,926.

PATENTED AUG. 13, 1907.

M. & H. E. MORTON.
WORK HOLDER FOR SHAPERS OR PLANERS.
APPLICATION FILED MAR. 10, 1906.

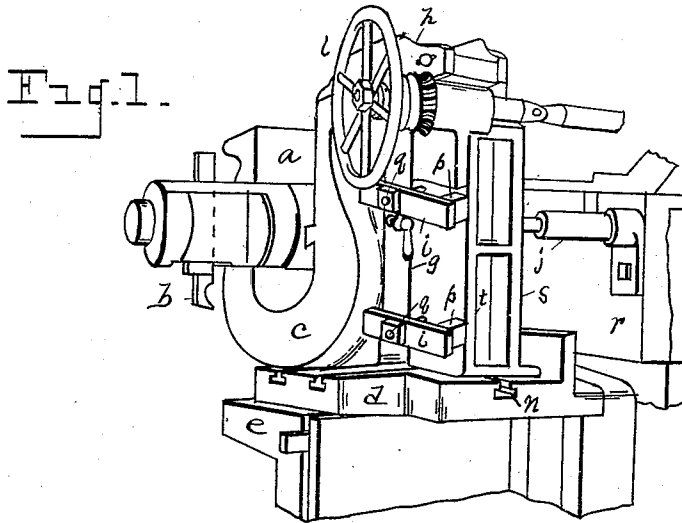

Fig. 2.

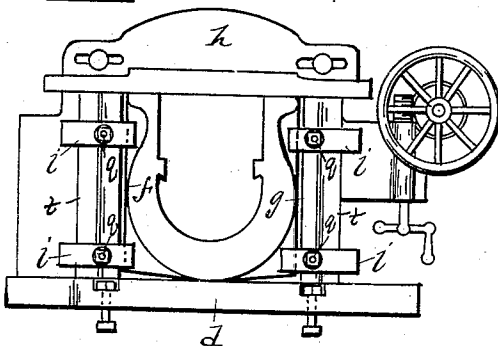

Fig. 3.

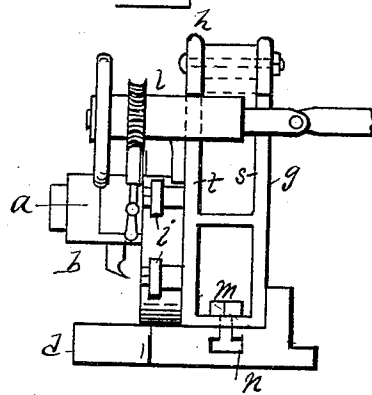
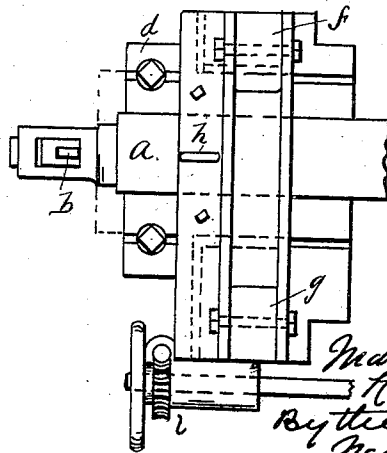

Fig. 4.



—Witnesses—

O. B. Baenziger,
e. m. Spielburg.

—Inventors—

Matthew Morton
Henry E. Morton
By their Attorney
Newell S. Wright.

UNITED STATES PATENT OFFICE.

MATTHEW MORTON AND HENRY E. MORTON, OF MUSKEGON HEIGHTS, MICHIGAN.

WORK-HOLDER FOR SHAPERS OR PLANERS.

No. 862,926.

Specification of Letters Patent.

Patented Aug. 13, 1907.

Application filed March 10, 1906. Serial No. 305,258.

To all whom it may concern:

Be it known that we, MATTHEW MORTON and HENRY E. MORTON, citizens of the United States, residing at Muskegon Heights, county of Muskegon, State of Michigan, have invented a certain new and useful Improvement in Work-Holders for Shapers or Planers, of which the following is a specification, reference being had to the accompanying drawings, which form a part of this specification.

Our invention has for its object a work holding device for a shaper or planer for finishing the interior of driving boxes for locomotives.

Our invention is especially designed and adapted to be used in connection with a shaper or planer for crowning and finishing locomotive driving boxes embodied in an application filed by us May 15, 1905, Serial Number 260,538. It is well understood, as stated in said application, that since the adoption of the large locomotives now in common use, and the heavy duty which they are called upon to perform, resort has been made to steel driving boxes which are very hard to finish by any of the old methods heretofore employed.

We carry out our invention as hereinafter described and claimed and illustrated in the accompanying drawings, in which,

Figure 1 is a view in perspective illustrating our invention. Fig. 2 is an end view of the mechanism for holding the work for finishing the inside of a locomotive driving box. Fig. 3 is a view in side elevation. Fig. 4 is a view in plan illustrating our invention.

In the drawings *a* represents a ram of a draw cut shaper carrying a cutting tool *b*. A driving box to be shaped is indicated at *c*. The work holding device comprises essentially a base plate *d*, the same being attached to a bed *e* of the machine. The base plate supports thereupon cheek plates *f* and *g* laterally adjustable upon said base plate toward and from the work in any suitable manner, as by bolts *m* engaged in a T shaped slot *n*. A cross piece *h* is adjustably engaged upon the top of the cheek pieces and extends over the work to hold the work rigidly in place in planing the same in various directions. The cheek pieces are provided also with clamping devices *i* to clamp against the work, the same being provided with backing blocks *p* under the

outer ends of said devices. These clamping devices may be set and held in place by bolts *g*. Back bearings are shown at *j* engaged upon the frame *r* of the machine to take the thrust of the cut. Against these the corresponding cheek plates contact, the back bearing serving a very important function in holding the work holding device in place in operating upon the work.

The back bearings *j*, it will be understood, are located between the frame *r* of the machine and the work holding device or cheek plates one on each side.

Rotary feeding mechanism is shown at *l* carried by one of the cheek plates. Said feeding mechanism being embodied, more particularly, in a pending application filed by us May 15, 1905, Serial #260,538, for shaper for grinding and finishing driving boxes on locomotives, &c.

The cheek plates are formed with broad front and rear flanges shown at *s* and *t*.

What we claim as our invention is:

1. A work holding device for a shaper or planing machine having in combination a support forwardly and rearwardly adjustable upon the bed of the machine, cheek pieces laterally adjustable upon said support, a cross piece adjustably engaged with the upper ends of the cheek pieces, clamping devices adjustably engaged with the cheek pieces to engage against the work, and backing blocks under the outer ends of said clamping devices to hold the clamping devices in given position.

2. The combination with a support of cheek pieces laterally adjustable upon the support, means to connect the upper ends of said cheek pieces, clamping devices adjustably engaged with said cheek pieces to engage the work, and backing blocks under the outer ends of said clamping devices to hold the clamping devices in given position.

3. A work holding device for a shaper or planing machine having in combination a support forwardly and rearwardly adjustable upon the bed of the machine, cheek pieces laterally adjustable upon said support, a cross piece adjustably engaged with the upper ends of the cheek pieces, clamping devices adjustably engaged with the cheek pieces to engage against the work, and means to hold the clamping devices in given position.

In testimony whereof, we have signed this specification in the presence of two subscribing witnesses.

MATTHEW MORTON.
HENRY E. MORTON.

Witnesses:

PERRY A. RANDALL,
FAY P. RANDALL.