



## INTERNATIONAL APPLICATION PUBLISHED UNDER THE PATENT COOPERATION TREATY (PCT)

<b>(51) International Patent Classification <sup>6</sup> :</b>  <b>G02B 5/18</b>	<b>A2</b>	<b>(11) International Publication Number:</b> <b>WO 97/26569</b>  <b>(43) International Publication Date:</b> 24 July 1997 (24.07.97)
<b>(21) International Application Number:</b> PCT/US97/00854 <b>(22) International Filing Date:</b> 17 January 1997 (17.01.97)  <b>(30) Priority Data:</b> 08/591,231              18 January 1996 (18.01.96)      US  <b>(71) Applicant:</b> THE BOARD OF TRUSTEES OF THE LELAND STANFORD JUNIOR UNIVERSITY [US/US]; Stanford, CA 94305 (US).  <b>(72) Inventors:</b> BLOOM, David, M.; 140 Golden Oak Drive, Portola Valley, CA 95025 (US). HUIBERS, Andrew; 118A Escondido Village, Stanford, CA 94305 (US).  <b>(74) Agent:</b> HAMRICK, Claude, A., S.; Bronson, Bronson & McKinnon L.L.P, Suite 600, Ten Almaden Boulevard, San Jose, CA 95113 (US).		<b>(81) Designated States:</b> CA, JP, European patent (AT, BE, CH, DE, DK, ES, FI, FR, GB, GR, IE, IT, LU, MC, NL, PT, SE).  <b>Published</b> <i>Without international search report and to be republished upon receipt of that report.</i>
<b>(54) Title:</b> METHOD AND APPARATUS FOR USING AN ARRAY OF GRATING LIGHT VALVES TO PRODUCE MULTICOLOR OPTICAL IMAGES  <b>(57) Abstract</b>  <p>A multicolor optical image-generating device comprised of an array of grating light valves (GLVs) organized to form light-modulating pixel units for spatially modulating incident rays of light. The pixel units are comprised of three subpixel components each including a plurality of elongated, equally spaced apart reflective grating elements arranged parallel to each other with their light-reflective surfaces also parallel to each other. Each subpixel component includes means for supporting the grating elements in relation to one another, and means for moving alternate elements relative to the other elements and between a first configuration wherein the component acts to reflect incident rays of light as a plane mirror, and a second configuration wherein the component diffracts the incident rays of light as they are reflected from the grating elements. The three subpixel components of each pixel unit are designed such that when red, green and blue light sources are trained on the array, colored light diffracted by particular subpixel components operating in the second configuration will be directed through a viewing aperture, and light simply reflected from particular subpixel components operating in the first configuration will not be directed through the viewing aperture.</p>		

**FOR THE PURPOSES OF INFORMATION ONLY**

Codes used to identify States party to the PCT on the front pages of pamphlets publishing international applications under the PCT.

AM	Armenia	GB	United Kingdom	MW	Malawi
AT	Austria	GE	Georgia	MX	Mexico
AU	Australia	GN	Guinea	NE	Niger
BB	Barbados	GR	Greece	NL	Netherlands
BE	Belgium	HU	Hungary	NO	Norway
BF	Burkina Faso	IE	Ireland	NZ	New Zealand
BG	Bulgaria	IT	Italy	PL	Poland
BJ	Benin	JP	Japan	PT	Portugal
BR	Brazil	KE	Kenya	RO	Romania
BY	Belarus	KG	Kyrgystan	RU	Russian Federation
CA	Canada	KP	Democratic People's Republic of Korea	SD	Sudan
CF	Central African Republic	KR	Republic of Korea	SE	Sweden
CG	Congo	KZ	Kazakhstan	SG	Singapore
CH	Switzerland	LI	Liechtenstein	SI	Slovenia
CI	Côte d'Ivoire	LK	Sri Lanka	SK	Slovakia
CM	Cameroon	LR	Liberia	SN	Senegal
CN	China	LT	Lithuania	SZ	Swaziland
CS	Czechoslovakia	LU	Luxembourg	TD	Chad
CZ	Czech Republic	LV	Latvia	TG	Togo
DE	Germany	MC	Monaco	TJ	Tajikistan
DK	Denmark	MD	Republic of Moldova	TT	Trinidad and Tobago
EE	Estonia	MG	Madagascar	UA	Ukraine
ES	Spain	ML	Mali	UG	Uganda
FI	Finland	MN	Mongolia	US	United States of America
FR	France	MR	Mauritania	UZ	Uzbekistan
GA	Gabon			VN	Viet Nam

1  
2  
3  
4  
5  
6  
7  
8  
9  
10  
11  
12  
13  
14  
15  
16  
17  
18  
19  
20  
21  
22  
23  
24  
25  
26  
27  
28  
29  
30  
31

## Specification

### METHOD AND APPARATUS FOR USING AN ARRAY OF GRATING LIGHT VALVES TO PRODUCE MULTICOLOR OPTICAL IMAGES

#### RELATED CASES

This application is a continuation-in-part of United States Patent Application Serial No. 08/404,139 filed on March 13, 1995, which is a division of U.S. Patent Application Serial No. 08/062,688 filed on May 20, 1993, which is a continuation-in-part of U.S. Patent Application Serial No. 07/876,078 filed on April 28, 1992.

#### BACKGROUND OF THE INVENTION

##### Field of the Invention

This invention relates generally to display apparatus for producing optical images, and more particularly to a method and apparatus using an array of sets of grating light valves and a plurality of colored light sources to provide a multicolor image that can be directly viewed or projected onto a screen.

This invention was made with Government support under contract DAAL03-88-K-0120 awarded by the U.S. Army Research Office. The Government has certain rights in this invention.

##### Brief Description of the Prior Art

Devices which modulate a light beam, e.g. by altering the amplitude, frequency or phase of the light, find a number of applications. An example of such a device is a spatial light modulator (SLM) which is an electronically or optically controlled device that consists of one or two-dimensional reconfigurable patterns of pixel elements, each of which can

1 individually modulate the amplitude, phase or polarization of  
2 an optical wavefront.

3       These devices have been extensively developed,  
4 particularly for applications in the areas of optical  
5 processing and computing. They can perform a variety of  
6 functions such as: analog multiplication and addition, signal  
7 conversion (electrical-to-optical, incoherent-to-coherent,  
8 amplification, etc.), nonlinear operations and short term  
9 storage. Utilizing these functions, SLMs have seen many  
10 different applications from display technology to optical  
11 signal processing. For example, SLMs have been used as optical  
12 correlators (e.g., pattern recognition devices, programmable  
13 holograms), optical matrix processors (e.g., matrix  
14 multipliers, optical cross-bar switches with broadcast  
15 capabilities, optical neural networks, radar beam forming),  
16 digital optical architectures (e.g., highly parallel optical  
17 computers) and displays.

18       The requirements for SLM technology depend strongly on  
19 the application in mind: for example, a display requires low  
20 bandwidth but a high dynamic range while optical computers  
21 benefit from high response times but don't require such high  
22 dynamic ranges. Generally, systems designers require SLMs with  
23 characteristics such as: high resolution, high speed (kHz  
24 frame rates), good gray scale high contrast ratio or modulation  
25 depth, optical flatness, VLSI compatible, easy handling  
26 capability and low cost. To date, no one SLM design can  
27 satisfy all the above requirements. As a result, different  
28 types of SLMs have been developed for different applications,  
29 often resulting in trade-offs.

30       A color video imaging system utilizing a cathode ray  
31 device with a target comprising an array of electrostatically  
32 deflectable light valves is disclosed in U.S. Patent No.  
33 3,896,338 to Nathanson et al. The light valve structure and

1 the arrangement of light valves as an array permits sequential  
2 activation of the light valves in response to a specific  
3 primary color video signal. The light valves are arranged in  
4 three element groupings, and a schlieren optical means is  
5 provided having respective primary color transmissive portions  
6 through which the light reflected from the deflected light  
7 valves is passed to permit projection of a color image upon a  
8 display screen.

9 Texas Instruments has developed a "Deformable Mirror  
10 Device (DMD)" that utilizes an electromechanical means of  
11 deflecting an optical beam. The mechanical motions needed for  
12 the operation of the DMD result in bandwidths limited to tens  
13 of kilohertz. However, this device generally provides better  
14 contrast ratios than the technologies previously described,  
15 provides acceptable "high resolution" and is compatible with  
16 conventional semiconductor processing techniques, such as CMOS.

17 Nematic and ferroelectric liquid crystals have also been  
18 used as the active layer in several SLMs. Since the electro-  
19 optic effect in liquid crystals is based on the mechanical  
20 reorientation of molecular dipoles, it is generally found that  
21 liquid crystals are faster than the DMD-type devices.  
22 Modulators using ferroelectric liquid crystals have exhibited  
23 moderate switching speeds (150  $\mu$ sec to 100 nsec), low-power  
24 consumption, VLSI compatible switching voltages (5-10 V), high  
25 extinction ratios, high resolution and large apertures.  
26 However, these devices suffer from the drawbacks of limited  
27 liquid crystal lifetimes and operating temperature ranges. In  
28 addition, the manufacturing process is complicated by alignment  
29 problems and film thickness uniformity issues.

30 Magneto-optic modulation schemes have been used to  
31 achieve faster switching speeds and to provide an optical  
32 pattern memory cell. Although these devices, in addition to  
33 achieving fast switching speeds, can achieve large contrast

1 ratios, they suffer from a low (<10%) throughput efficiency and  
2 are, therefore, often unsuitable for many applications.

3 The need is therefore for a light modulation device which  
4 overcomes these drawbacks.

5 Beside SLMs, another area of use of light modulators is  
6 in association with fiber optics apparatus. Fiber optic  
7 modulators are electronically controlled devices that modulate  
8 light intensity and are designed to be compatible with optical  
9 fibers. For high speed communication applications, lithium  
10 niobate ( $\text{LiNbO}_3$ ) traveling wave modulators represent the state-  
11 of-the-art, but there is a need for low power, high efficiency,  
12 low loss, inexpensive fiber optic modulators, that can be  
13 integrated with silicon sensors and electronics, for data  
14 acquisition and medical applications. A typical use of a  
15 modulator combined with fiber optic technology, for example, is  
16 a data acquisition system on an airplane which consists of a  
17 central data processing unit that gathers data from remote  
18 sensors. Because of their lightweight and electro-magnetic  
19 immunity characteristics, fiber optics provide an ideal  
20 communication medium between the processor and the sensors  
21 which produce an electrical output that must be converted to an  
22 optical signal for transmission. The most efficient way to do  
23 this is to have a continuous wave laser at the processor and a  
24 modulator operating in reflection at the sensor. In this  
25 configuration, it is also possible to deliver power to the  
26 sensor over the fiber.

27 In this type of application the modulator should operate  
28 with high contrast and low insertion loss to maximize the  
29 signal to noise ratio and have low power consumption. It  
30 should further be compatible with silicon technology because  
31 the sensors and signal conditioning electronics used in these  
32 systems are largely implemented in silicon.

1 Another use of a modulator combined with fiber optic  
2 technology is in the monitoring of sensors that are surgically  
3 implanted in the human body. Here optical fibers are preferred  
4 to electrical cables because of their galvanic isolation, and  
5 any modulator used in these applications should exhibit high  
6 contrast combined with low insertion loss because of signal to  
7 noise considerations. Furthermore, as size is important in  
8 implanted devices, the modulator must be integratable with  
9 silicon sensors and electronics.

10 Modulators based on the electro-optic, Franz-Keldysh,  
11 Quantum-Confined-Stark or Wannier-Stark effect in III-V  
12 semiconductors have high contrast and low insertion loss, but  
13 are expensive and not compatible with silicon devices.  
14 Waveguide modulators employing glass or epi-layers on silicon,  
15 require too much area and too complex fabrication to be easily  
16 integratable with other silicon devices. Silicon modulators  
17 that do not employ waveguides and that are based on the plasma  
18 effect, require high electrical drive power and do not achieve  
19 high contrast.

20 A need therefore exists for improved light modulator  
21 apparatus having low power requirements, high efficiency, low  
22 loss, low cost and compatibility with silicon technology.

23 A need also exists for a multicolor display device using  
24 light modulator technology of the type described herein.

25

26

#### SUMMARY OF THE INVENTION

##### Objects of the Invention

28 An object of the present invention is thus to provide a  
29 novel display apparatus using grating light valve modulators  
30 that respond to electronic input signals and generate images  
31 that can be viewed directly or projected onto a viewing screen.

32 Another object of this invention is to provide a light-  
33 modulating display device that exhibits the following

1 characteristics: high resolution, high speed (kHz frame  
2 rates), high contrast ratio or modulation depth, optical  
3 flatness, VLSI compatible, easy handling capability and low  
4 cost.

5 A further object of this invention is to provide a light-  
6 modulating, visual image-generating device that has a tolerance  
7 for high optical power and good optical throughput.

8 Another object of the present invention is to provide an  
9 optical display device using groupings of grating light valves  
10 as light-modulating, pixel-forming elements.

11 Yet another object of this invention is to provide a  
12 light modulator which is compatible with semiconductor  
13 processing.

14 Still another object of this invention is to provide a  
15 light modulator capable of use with fiber optic technology.

16 Yet another object of this invention is to provide a  
17 light modulator which is capable of modulating white light to  
18 produce colored light.

19

## 20 Summary

21 Briefly, a presently preferred embodiment of this  
22 invention includes a visual image-generating device comprised  
23 of an array of grating light valves (GLVs) organized to form  
24 light-modulating pixel units for spatially modulating incident  
25 rays of light. The pixel units are comprised of three subpixel  
26 components, each including a plurality of elongated, equally  
27 spaced apart reflective grating elements arranged parallel to  
28 each other with their light-reflective surfaces also parallel  
29 to each other. Each subpixel component includes means for  
30 supporting the grating elements in relation to one another  
31 wherein alternate elements are configured to be movable  
32 relative to other elements which are non-movable, and between a  
33 first configuration wherein the component acts to reflect

1 incident rays of light as a plane mirror, and a second  
2 configuration wherein the component diffracts the incident rays  
3 of light as they are reflected from the grating elements. In  
4 operation, the light-reflective surfaces of the elements of  
5 each subpixel component remain parallel to each other in both  
6 the first and the second configurations, and the perpendicular  
7 spacing at rest between the planes of the reflective surfaces  
8 of adjacent elements is equal to  $m/4$  times the wavelength of  
9 the incident rays of light, wherein  $m$  = an even whole number  
10 or zero when the elements are in the first configuration and  $m$   
11 = an odd number when the elements are in the second  
12 configuration.

13 The three subpixel components of each pixel unit are  
14 designed such that when red, green and blue light sources are  
15 trained on the array, colored light diffracted by particular  
16 subpixel components operating in the second configuration will  
17 be directed through a viewing aperture, and light simply  
18 reflected from particular subpixel components operating in the  
19 first configuration will not be directed through the viewing  
20 aperture.

21 It will be appreciated by one of ordinary skill in the  
22 art that the fundamentals of the present invention can be  
23 similarly implemented by diffracting the light away from the  
24 viewing aperture and reflecting to the aperture.

25 One embodiment of the invention includes an array of  
26 deformable grating light valves with grating amplitudes that  
27 can be controlled electronically, and is comprised of a  
28 reflective substrate with a plurality of the deformable grating  
29 elements suspended above it. The deformable grating elements  
30 are implemented in silicon technology, using micromachining and  
31 sacrificial etching of thin films to fabricate the gratings.  
32 Typically the gratings are formed by lithographically etching a  
33 film made of silicon nitride, aluminum, silicon dioxide or any

1 other material which can be lithographically etched. Circuitry  
2 for addressing and multiplexing the light valves is fabricated  
3 on the same silicon substrate and is thus directly integrated  
4 with the light-modulating mechanisms.

5 Direct integration with electronics provides an important  
6 advantage over non-silicon based technologies like liquid  
7 crystal oil-film light valves and electro-optic SLMs, because  
8 the device can be made smaller and with greater accuracy.  
9 Moreover, the device demonstrates simplicity of fabrication and  
10 can be manufactured with only a few lithographic steps.

11 A further advantage of the present invention is that  
12 since the grating light valves utilize diffraction rather than  
13 deflection of the light beam as the modulating mechanism, the  
14 required mechanical motions are reduced from several microns  
15 (as in deformable mirror devices) to tenths of a micron, thus  
16 allowing for a potential three orders of magnitude increase in  
17 operational speed over other SLM technology. This speed is  
18 comparable to the fastest liquid crystal modulators, but  
19 without the same complexity in the manufacturing process.

20 A still further advantage of the present invention is  
21 that it provides a miniature means for converting video data to  
22 an optical image that can be viewed directly, or can be  
23 projected onto a screen or film, or the data can be coupled  
24 into a fiberoptic cable for optical transmission to a remote  
25 location.

26 These and other objects and advantages of the present  
27 invention will no doubt become apparent to those skilled in the  
28 art after having read the following detailed description of the  
29 preferred embodiment which is illustrated in the several  
30 figures of the drawing.

31

32

IN THE DRAWING

1 FIG. 1 is an isometric, partially cut-away view of a  
2 single grating light valve or modulator;

3 FIGS. 2(a)-(d) are cross-sections through a silicon  
4 substrate illustrating the manufacturing process of the  
5 modulator illustrated in FIG. 1;

6 FIG. 3 illustrates the operation of the modulator of FIG.  
7 1 in its "non-diffracting" mode;

8 FIG. 4 illustrates the operation of the modulator of FIG.  
9 3 in its "diffracting" mode;

10 FIG. 5 is a graphical representation of the modulation of  
11 a laser beam by the modulator of FIG. 1;

12 FIG. 6 is an illustration of one way in which one  
13 modulator can be combined with other modulators to form a  
14 complex modulator;

15 FIG. 7 illustrates the operation of the modulator in the  
16 modulation of white light to produce colored light;

17 FIG. 8 is a cross-section similar to that in FIG. 3,  
18 illustrating an alternative embodiment of the modulator in its  
19 "non-diffracting" mode;

20 FIG. 9 is a cross-section similar to that in FIG. 4,  
21 illustrating the modulator of FIG. 8 in its "diffracting" mode;

22 FIG. 10 is a pictorial view illustrating a further  
23 embodiment of a modulator;

24 FIG. 11 is a cross-section taken along line 11-11 in FIG.  
25 10;

26 FIGS. 12a to 20 are sections illustrating further  
27 embodiments of the modulator;

28 FIGS. 21, 22 and 28 are schematic diagrams illustrating  
29 embodiments of the present invention using either a white light  
30 source or colored light sources;

31 FIGS. 23-26 illustrate arrays of three color pixel units  
32 and show several alternative grating element configurations in  
33 accordance with the present invention; and

1 FIG. 27 is a partially broken perspective view of a  
2 pager-style communication device in accordance with the present  
3 invention.

4

5

#### DESCRIPTION OF PREFERRED EMBODIMENTS

6

##### First Embodiment

7 The grating light valve (GLV) or modulator is generally  
8 indicated at 10 in FIG. 1. The modulator 10 includes a number  
9 of elongated beam-like elements 18 which define a grating that,  
10 as will be later explained, can be used to spatially modulate  
11 an incident light beam. The elements 18 are formed integrally  
12 with an encompassing frame 21 which provides a relatively rigid  
13 supporting structure and maintains the tensile stress within  
14 the elongated elements 18. This structure defines a grating 20  
15 which is supported by a partially etched silicon dioxide film  
16 12 at a predetermined distance of 213 nm above the surface of a  
17 silicon substrate 16.

18 Before commencing the description of how the modulator 10  
19 is fabricated, it should be noted that, in this case, each of  
20 the elements 18 are 213 nm thick and are suspended a distance  
21 of 213 nm clear of the substrate 16. This means that the  
22 distance from the top of each element to the top of the  
23 substrate is 426 nm. This distance is known as the grating  
24 amplitude.

25 One method of fabricating the modulator 10 is illustrated  
26 in FIG. 2(a)-(d).

27 The first step, as illustrated in FIG. 2(a), is the  
28 deposition of an insulating layer 11 made of stoichiometric  
29 silicon nitride topped with a buffer layer of silicon dioxide.  
30 This is followed by the deposition of a sacrificial silicon  
31 dioxide film 12 and a low-stress silicon nitride film 14, both  
32 213 nm thick, on a silicon substrate 16. The low-stress  
33 silicon nitride film 14 is achieved by incorporating extra

1 silicon (beyond the stoichiometric balance) into the film,  
2 during the deposition process. This reduces the tensile stress  
3 in the silicon nitride film to roughly 200 MPa.

4 In the second step, which is illustrated in FIG. 2(b),  
5 the silicon nitride film 14 is lithographically patterned and  
6 dry-etched into a grid of grating elements in the form of  
7 elongated beam-like elements 18. After this lithographic  
8 patterning and etching process a peripheral silicon nitride  
9 frame 21 remains around the entire perimeter of the upper  
10 surface of the silicon substrate 16. In an individual  
11 modulator, all of the elements are of the same dimension and  
12 are arranged parallel to one another with the spacing between  
13 adjacent elements equal to the width thereof. Depending on the  
14 design of the modulator, however, elements could typically be  
15 1, 1.5 or 2 $\mu$ m wide with a length that ranges from 10 $\mu$ m to  
16 120 $\mu$ m.

17 After the patterning process of the second step, the  
18 sacrificial silicon dioxide film 12 is etched in hydrofluoric  
19 acid, resulting in the configuration illustrated in FIG. 2(c).

20 It can be seen that each element 18 now forms a free standing  
21 silicon nitride bridge, 213 nm thick, which is suspended a  
22 distance of 213 nm (this being the thickness of the etched away  
23 sacrificial film 12) clear of the silicon substrate. As can  
24 further be seen from this figure, the silicon dioxide film 12  
25 is not entirely etched away below the frame 21, and so the  
26 frame is supported, at a distance of 213 nm, above the silicon  
27 substrate 16 by this remaining portion of the silicon dioxide  
28 film 12. The elements 18 are stretched within the frame and  
29 kept straight by the tensile stress imparted to the silicon  
30 nitride film 14 during the deposition of that film.

31 The last fabrication step, illustrated in FIG. 2(d), is  
32 sputtering, through a stencil mask, of a 50 nm thick aluminum  
33 film 22 to enhance the reflectance of both the elements 18 and

1 the substrate 16 and to provide a first electrode for applying  
2 a voltage between the elements and the substrate. A second  
3 electrode is formed by sputtering an aluminum film 24, of  
4 similar thickness, onto the base of the silicon substrate 16.

5 It should be realized that the above described  
6 manufacturing process illustrates only one type of modulator  
7 and only one fabrication process. A more detailed description  
8 of other fabrication possibilities will be given below with  
9 reference to FIGS. 12 to 18.

10 The operation of the modulator 10 is illustrated with  
11 respect to FIGS. 3 and 4.

12 In FIG. 3 the modulator 10 is shown with no voltage  
13 applied between the substrate 16 and the individual elements 18  
14 and with a lightwave, generally indicated as 26, of a  
15 wavelength  $\lambda = 852$  nm is incident upon the it. The grating  
16 amplitude of 426 nm is therefore equal to half of the  
17 wavelength of the incident light with the result that the total  
18 path length difference for the light reflected from the  
19 elements and from the substrate equals the wavelength of the  
20 incident light. Consequently, light reflected from the  
21 elements and from the substrate add in phase and the modulator  
22 10 acts to reflect the light as a flat mirror.

23 However, as illustrated in FIG. 4, when a voltage is  
24 applied between the elements 18 and the substrate 16 the  
25 electrostatic forces pull the elements 18 down onto the  
26 substrate 16, with the result that the distance between the top  
27 of the elements and the top of the substrate is now 213 nm. As  
28 this is one quarter of the wavelength of the incident lights,  
29 the total path length difference for the light reflected from  
30 the elements and from the substrate is now one half of the  
31 wavelength (426 nm) of the incident light and the reflections  
32 interfere destructively, causing the light to be diffracted, as  
33 indicated at 28.

1        Thus, if this modulator is used in combination with a  
2 system, for detecting the diffracted light, which has a  
3 numerical aperture sized to detect one order of diffracted  
4 light from the grating e.g., the zero order, it can be used to  
5 modulate the reflected light with high contrast.

6        The electrical, optical and mechanical characteristics of  
7 a number of modulators, similar in design to the modulator  
8 illustrated above but of different dimensions were investigated  
9 by using a Helium Neon laser (of 633 nm wavelength) focused to  
10 a spot size of 36 $\mu$ m on the center portion of each modulator.  
11 This spot size is small enough so that the curvature of the  
12 elements in the region where the modulator was illuminated can  
13 be neglected, but is large enough to allow the optical wave to  
14 be regarded as a plane wave and covering enough grating periods  
15 to give good separation between the zero and first order  
16 diffraction modes resulting from the operation of the  
17 modulator. It was discovered that grating periods (i.e., the  
18 distance between the centerlines of two adjacent elements in  
19 the grating) of 2,3 and 4  $\mu$ m and a wavelength of 633 nm  
20 resulted in first order diffraction angles of 18 $^\circ$ , 14 $^\circ$  and 9 $^\circ$   
21 respectively.

22        One of these first order diffracted light beams was  
23 produced by using a grating modulator with 120  $\mu$ m-long and 1.5  
24  $\mu$ m-wide elements at atmospheric pressure together with a HeNe  
25 light beam modulated at a bit rate of 500 kHz detected by a  
26 low-noise photoreceiver and viewed on an oscilloscope. The  
27 resulting display screen 27 of the oscilloscope is illustrated  
28 in FIG. 5.

29        However, before proceeding with a discussion of the  
30 features illustrated in this figure, the resonant frequency of  
31 the grating elements should first be considered.

1       The resonant frequency of the mechanical structure of the  
2 diffraction grating of the modulator was measured by driving  
3 the modulator with a step function and observing the ringing  
4 frequency. The area of the aluminum on the modulator is  
5 roughly  $0.2 \text{ cm}^2$ , which corresponds to an RC limited 3-dB  
6 bandwidth of 1 MHz with roughly 100 ohms of series resistance.

7       This large RC time constant slowed down the step function,  
8 however, enough power existed at the resonant frequency to  
9 excite vibrations, even in the shorter elements. Although the  
10 ringing could be observed in normal atmosphere, the Q-factor  
11 was too low (approximately 1.5) for accurate measurements, so  
12 the measurements were made at a pressure of 150 mbar. At this  
13 pressure, the Q-factor rose to 8.6, demonstrating that air  
14 resistance is the major damping mechanism, for a grating of  
15 this nature, in a normal atmosphere.

16       Nonetheless, it was found that due to the high tensile  
17 stress in the beam-like elements, tension is the dominant  
18 restoring force, and the elements could therefore be modeled as  
19 vibrating strings. When this was done and the measured and  
20 theoretically predicted resonance frequencies were compared, it  
21 was found that the theory was in good agreement with the  
22 experimental values, particularly when considering the  
23 uncertainty in tensile stress and density of the elements. As  
24 it is known that the bandwidth of forced vibrations of a  
25 mechanical structure is simply related to the resonance  
26 frequency and Q-factor, a Q-factor of 1.5 yields a 1.5 dB  
27 bandwidth of the deformable grating modulator 1.4 times larger  
28 than the resonance frequency. The range of bandwidths for  
29 these gratings is therefore from 1.8 MHz for the deformable  
30 grating modulator with  $120 \mu\text{m}$  long elements to 6.1 MHz for the  
31 deformable grating modulator with  $40 \mu\text{m}$  long elements.

32       Returning now to FIG. 5, it should be noted that with an  
33 applied voltage swing of 3 V, a contrast of 16dB for the 120

1  $\mu\text{m}$ -long bridges could be observed. Here the term "modulation  
2 depth" is taken to mean the ratio of the change in optical  
3 intensity to peak intensity.

4 The input (lower trace 29a) on the screen 27 represents a  
5 pseudo-random bit stream switching between 0 and -2.7 V across  
6 a set of grating devices on a 1 cm by 1 cm die. The observed  
7 switching transient with an initial fast part followed by a RC  
8 dominated part, is caused by the series resistance of the  
9 deformable grating modulator, which is comparable to a 50 ohm  
10 source resistance.

11 The output (upper trace 29b) on the screen corresponds to  
12 the optical output of a low-noise photoreceiver detecting the  
13 first diffraction order of the grating used. The output (upper  
14 trace 29b) from the photoreceiver is inverted relative to the  
15 light detected from the deformable grating and is high when the  
16 elements are relaxed and low when the elements are deflected.  
17 Ringing is observed only after the rising transient, because of  
18 the quadratic dependence of the electro-static force on the  
19 voltage (during switching from a voltage of -2.7 V to 0 V, the  
20 initial, faster part of the charging of the capacitor  
21 corresponds to a larger change in electro-static force, than  
22 when switching the opposite way). This ringing in the received  
23 signal indicates a decay close to critical damping.

24 Furthermore, it was found that because the capacitance  
25 increases as the beam-like elements are pulled toward the  
26 substrate, the voltage needed for a certain deflection is not a  
27 linearly increasing function of this deflection. At a certain  
28 applied voltage condition, an incremental increase in the  
29 applied voltage causes the elements to be pulled spontaneously  
30 to the substrate (to latch) and this voltage is known as the  
31 "switching voltage" of the modulator. The switching voltage  
32 was found to be 3.2 V for gratings with 120  $\mu\text{m}$  long elements  
33 and, if it is assumed that tension dominates the restoring

1 forces, the switching voltage is inversely proportional to the  
2 element length and therefore, the predicted switching voltage  
3 for 40  $\mu\text{m}$  long elements will be 9.6 V.

4       The importance of the switching voltage is that below  
5 this voltage, the deformable grating modulator can be operated  
6 in an analog fashion, however, if a voltage greater than the  
7 switching voltage is applied to the modulator it acts in a  
8 digital manner. Nonetheless, it is important to note that  
9 operating the modulator to the point of contact is desirable  
10 from an applications point of view, because as discussed above  
11 when the elements are deflected electrostatically, an  
12 instability exists once the element deflection goes beyond the  
13 one-third point. This results in hysteretic behavior which  
14 will "latch" the element in the down position. This latching  
15 feature gives the modulator the advantages of an active matrix  
16 design without the need for active components. A further  
17 advantage of this latching feature is that once the element has  
18 "latched" it requires only a very small "holding voltage", much  
19 smaller than the original applied voltage, to keep the element  
20 in its latched configuration. This feature is particularly  
21 valuable in low power applications where efficient use of  
22 available power is very important.

23       The use of the modulator of this invention in displays  
24 requires high yield integration of individual modulator units  
25 into 2-D arrays such as that illustrated in FIG. 6. This  
26 figure shows a plurality of contiguous grating modulator units  
27 which can be used to provide a gray-scale operation. Each of  
28 the individual modulators consists of a different number of  
29 elements, and gray-scale can be obtained by addressing each  
30 modulator in a binary-weighted manner. The hysteresis  
31 characteristic for latching (as described above) can be used  
32 to provide gray-scale variation without analog control of the  
33 voltage supplied to individual grating modulator elements.

1           In FIG. 7 the use of the GLV, in combination with other  
2 gratings (GLVs), for modulating white light to produce colored  
3 light is illustrated. This approach takes advantage of the  
4 ability of a GLV to separate or disperse a light spectrum into  
5 its constituent colors. By constructing an array of pixel  
6 units, each including separate but contiguous red, green and  
7 blue modulation units of GLVs, each with a grating period  
8 designed to diffract the appropriate color into a single  
9 optical system, a color display that is illuminated by white  
10 light can be achieved. This approach may be attractive for  
11 large area projection displays.

12

### 13 Alternative Embodiments

14           In FIGS. 8 and 9 an alternative embodiment of the  
15 diffraction modulator 30 of the invention is illustrated. In  
16 this embodiment the modulator 30 consists of a plurality of  
17 equally spaced, equally sized, fixed elements 32 and a  
18 plurality of equally spaced, equally sized, movable beam-like  
19 elements 34 in which the movable elements 34 lie in the spaces  
20 between the fixed elements 32. Each fixed element 32 is  
21 supported on and held in position by a body of supporting  
22 material 36 which runs the entire length of the fixed element  
23 32. The bodies of material 36 are formed during a lithographic  
24 etching process in which the material between the bodies 36 is  
25 removed.

26           As can be seen from FIG. 8 the fixed elements 32 are  
27 arranged to be coplanar with the movable elements 34 and  
28 present a flat upper surface which is coated with a reflective  
29 layer 38. As such the modulator 30 acts as a flat mirror when  
30 it reflects incident light, however, when a voltage is applied  
31 between the elements and an electrode 40 at the base of the  
32 modulator 30 the movable elements 34 move downwards as is  
33 illustrated in FIG. 9. By applying different voltages the

1 resultant forces on the elements 34 and, therefore, the amount  
2 of deflection of the movable elements 34 can be varied.  
3 Accordingly, when the grating amplitude (defined as the  
4 perpendicular distance  $d$  between the reflective layers 38 on  
5 adjacent elements) is  $m/4$  times the wavelength of the light  
6 incident on the grating 30, the modulator 30 will act as a  
7 plane mirror when  $m = 0, 2, 4...$  (i.e., an even number or zero)  
8 and as a reflecting diffraction grating when  $m = 1, 3, 5...$   
9 (i.e., an odd number). In this manner the modulator 30 can  
10 operate to modulate incident light in the same manner as the  
11 modulator illustrated as the first embodiment.

12 Yet another embodiment of the modulator of the invention  
13 is illustrated in FIGS. 10 and 11. As with the other  
14 embodiments, this modulator 41 consists of a sacrificial  
15 silicon dioxide film 42, a silicon nitride film 44 and a  
16 substrate 46. In this embodiment, however, the substrate 46  
17 has no reflective layer formed thereon and only the silicon  
18 nitride film 44 has a reflective coating 45 formed thereon. As  
19 is illustrated in FIG. 10 the deformable elements 48 are  
20 coplanar in their undeformed state and lie close to one another  
21 so that together they provide a substantially flat reflective  
22 surface. The elements 48 are, however, formed with a neck 50  
23 at either end, which is off-center of the longitudinal center  
24 line of each of the elements 48.

25 When a uniformly distributed force, as a result of an  
26 applied voltage for example, is applied to the elements 48 the  
27 resultant force  $F$ , for each element 48, will act at the  
28 geometric center 52 of that element. Each resultant force  $F$  is  
29 off-set from the axis of rotation 54 (which coincides with the  
30 centerline of each neck 50), resulting a moment of rotation or  
31 torque being applied to each element 48. This causes a  
32 rotation of each element 48 about its axis 54 to the position

1 48' indicated in broken lines. This is known as "blazing" a  
2 diffraction grating.

3 As can be seen from FIG. 11, the reflective planes 56 of  
4 the elements 48 remain parallel to each other even in this  
5 "blazed" configuration and therefore, the grating amplitude  $d$   
6 is the perpendicular distance between the reflective surfaces  
7 of adjacent elements. This "blazed grating" will operate to  
8 diffract light in the same manner as a sawtooth grating.

9 The basic fabrication procedure of yet another embodiment  
10 of the modulator 68 is illustrated in FIGS. 12(a)-(c). First,  
11 132 nm of silicon dioxide layer 70 followed by 132 nm of  
12 silicon nitride layer 72 are deposited on a boron-doped wafer  
13 74 using low pressure chemical vapor deposition techniques.  
14 The tensile stress in the silicon nitride layer 72 ranges from  
15 40 to 800 MPa, depending on the ratio of the dichlorosilane and  
16 ammonia gases present during the deposition process. Tensile  
17 stress effects the performance of the modulator of the  
18 invention as higher tensile stress results in stiffer elements  
19 and, therefore, faster switching speeds but also requires  
20 higher voltages to operate the modulator.

21 Thereafter a photoresist (not shown) is layered onto the  
22 silicon nitride layer 72 and patterned after which the silicon  
23 nitride layer 72 is dry-etched down to the silicon dioxide  
24 layer 70 (FIG. 12(a)). The oxide layer 70 is also partially  
25 dry-etched as shown in FIG. 12(b). Then the photoresist is  
26 stripped.

27 Photoresist removal is followed by a buffered oxide etch  
28 which isotropically undercuts the silicon dioxide 70 from  
29 beneath the silicon nitride. Since the nitride frame (not  
30 shown) is wider than the remaining nitride elements 76, some  
31 oxide is left beneath it to act as an oxide spacer. Processing  
32 is completed when 30 nm layer of aluminum is evaporated onto

1 the elements 76 and the substrate 74 to form the top and bottom  
2 electrodes and to enhance the reflectivity.

3 Typically the elongated elements formed by this process  
4 would be either 1.0, 1.25 or 1.50  $\mu\text{m}$  wide, which respectively  
5 can be used for blue, green and red light modulators.

6 It is possible that, when the released element structures  
7 are dried, the surface tension forces of the solvents could  
8 bring the elements down and cause them to stick. In addition,  
9 when the modulators are operated the elements could come down  
10 into intimate contact with the substrate and stick.

11 Various methods could be used to prevent the sticking of  
12 the nitride elements to the substance: freeze-drying, dry  
13 etching of a photoresist-acetone sacrificial layer, and OTS  
14 monolayer treatments. These techniques seek to limit stiction  
15 by reducing the strength of the sticking-specific-force (that  
16 is, force per unit of contact area). Furthermore, the use of  
17 stiffer elements by using shorter elements and tenser nitride  
18 films, is possible.

19 Since the force causing the elements to stick to the  
20 underlying material is the product of the contact area between  
21 the two surfaces and the specific force, however, other methods  
22 to reduce sticking could include:

23 (a) reducing the area of contact by roughening or  
24 corrugating; and

25 (b) reducing the specific force by changing the chemical  
26 nature of the surfaces.

27 One method of reducing the contact area could be by  
28 providing a composite element in which the top of the element  
29 is aluminum to enhance reflectivity, the second layer is  
30 stressed nitride to provide a restoring force, and the third  
31 layer is coarse-grained polysilicon to reduce effective contact  
32 area.

1 Still other methods of reducing the contact area between  
2 the bottoms of the elements and the substrate exist and are  
3 described below with reference to FIGS. 13(a)-15(c).

4 As is illustrated in FIGS. 13(a) and (b), contact area  
5 can be reduced by patterning lines 79 on the substrate or on  
6 the bottoms of the elements. These lines 79 are typically 1  $\mu\text{m}$   
7 wide, 200 $\text{\AA}$  high and spaced at 5  $\mu\text{m}$  centers. As shown, the  
8 lines are arranged perpendicular to the direction of the  
9 elements and located on the substrate. Alternatively the lines  
10 could be parallel to the direction of the elements.

11 The procedure is to first pattern and dry etch a blank  
12 silicon wafer. Then a low temperature oxide layer 80 or other  
13 planar film is deposited followed by processing as above to  
14 yield the configuration in FIG. 13(b).

15 A different way of obtaining the same result is  
16 illustrated in FIGS. 14(a) and (b), in which oxide is grown on  
17 a bare silicon substrate 94, and patterned and dry or wet  
18 etched to form grooves 89, 1  $\mu\text{m}$  wide on 5  $\mu\text{m}$  centers, 200 $\text{\AA}$  deep  
19 after which processing continues as described above. This  
20 yields the final structure shown in FIG. 14(b).

21 Yet another method of reducing the geometric area of  
22 contacting surfaces is illustrated in FIGS. 15(a)-(c).

23 After photoresist removal (FIG. 15(a)), a second layer  
24 100 of about 50 nm nitride is deposited. As shown in FIG.  
25 15(b), this second layer also coats the side-walls, such that a  
26 following anisotropic plasma etch which removes all of the  
27 second layer nitride 100 in the vertically exposed areas,  
28 leaves at least one side-wall 102 that extends below the bottom  
29 of each nitride element 104. It is at this point that the  
30 buffered oxide etch can be done to release the elements to  
31 yield the structure of FIG. 15(c). With the side-wall spacer  
32 acting as inverted rails for lateral support, contact surfaces  
33 are minimized preventing sticking. In operation, it is

1 believed that the elements, when deformed downwards, will only  
2 contact the substrate at the areas of the downwardly protruding  
3 rails.

4 As the adhesion forces are proportional to the area in  
5 contact, they are substantially reduced by this configuration  
6 resulting in operational gratings with elements having a  
7 tensile stress on the order 200 MPa and being up to 30  $\mu\text{m}$  long.

8 The rail structures also operate to maintain optically flat  
9 surfaces and have the advantage of not requiring additional  
10 masking steps during their manufacture.

11 Sticking can also be addressed by changing the materials  
12 of the areas that will come into contact. It is thought that  
13 although the level of sticking between different materials will  
14 be similar, the surface roughness of films differs  
15 significantly, effectively changing the contact area.

16 One method of achieving this is that the element material  
17 can be changed to polycrystalline silicon. This material will  
18 have to be annealed to make it tensile. It can also use  
19 silicon dioxide as its sacrificial layer underneath.

20 Another method is to use a metallic element material  
21 (e.g. aluminum) and an organic polymer such as polyamide as the  
22 sacrificial layer.

23 Yet another method is to use polymorphic element  
24 material. This results in an initial multilayer structure  
25 which can be patterned, as described in FIGS. 16(a)-16(c) to  
26 form a element structure mostly made of silicon nitride but  
27 which has contact areas of other engineered materials.

28 This is done by:

29 (i) First depositing a substrate 108 covering layer 110  
30 with low or high-stress silicon nitride or fine- or course-  
31 grained polymorphic element material. This layer should be  
32 approximately  $100\text{\AA}$  and acts as a first (lower) contact  
33 surface.

1           (ii) Depositing a layer 112 of low temperature oxide at  
2 400°C.

3           (iii) Depositing a second contacting surface layer 114.  
4 This layer should be thin (about 100Å) so as not to change the  
5 mechanical properties of the silicon nitride element.

6           (iv) Finally, depositing the silicon nitride element  
7 material 116, after which dry-etching and undercutting similar  
8 to that described above is done.

9           One slight variation on the above process, which is  
10 illustrated in FIGS. 17(a)-(e), is to deposit on the substrate  
11 a layer 120 of silicon dioxide over which a layer 122 of  
12 tungsten can be selectively deposited (e.g. by depositing only  
13 over exposed silicon surfaces). Instead of fully releasing the  
14 elements, as before, the oxide layer 120 is only partially  
15 removed by timing the etch to leave a thin column 124 of  
16 material supporting the structures from underneath (see FIG.  
17 17(c)). Thereafter the wafers are placed back into a selective  
18 tungsten deposition chamber to get a layer 126 of tungsten  
19 covering the exposed silicon areas but not on the oxide columns  
20 124 nor on the silicon nitride elements 128.

21           After depositing a thin layer 126 of tungsten as a new  
22 contact area, the oxide etch can be continued to fully release  
23 the elements 128 which, when deflected will come down onto a  
24 tungsten base.

25           Individual diffraction grating modulators in all of the  
26 above embodiments are approximately 25 μm square. To produce a  
27 device capable of modulating colored light (which contains red,  
28 green, and blue modulator regions) would therefore require a  
29 device 25 x 75 μm<sup>2</sup>. To reduce this to a square device, each of  
30 the individual modulators must be reduced to 25 x 8 μm<sup>2</sup> by  
31 shortening the elements. Reduction of size in the other  
32 dimension is not possible because of diffraction limitations.

1           However, calculations reveal that 8  $\mu\text{m}$  elements would, if  
2 constructed as described above, be too stiff to switch with  
3 practical voltages. A possible solution to this, as  
4 illustrated in FIGS. 18(a)-18(b), is the use of cantilever  
5 elements 130 rather than elements which are supported at either  
6 end. This is because elements that are supported at both ends  
7 are twice as stiff as cantilevers, which are supported at only  
8 one end.

9           Two-dimensional arrays of diffraction gratings may be  
10 constructed by defining two sets of conductive electrodes: the  
11 top, which are constructed as in the one-dimensional arrays out  
12 of metal or conductive silicon lithographically defined on the  
13 element, and the bottom. Two methods may be used to define the  
14 bottom electrodes.

15           In the first method, illustrated in FIGS. 19(a) and (b),  
16 an oxide layer 140 is grown or deposited on a bare P- or N-type  
17 silicon wafer 142. The oxide is patterned and the wafer 142  
18 subjected to a dopant diffusion of the opposite conductivity  
19 type, respectively N- or P-type, to produce a doped region 144.

20           The beam-like elements are then fabricated on top of the  
21 diffused areas as previously described and aluminum is  
22 evaporated onto the surfaces as before. The diffused regions  
23 are held at ground and the PN junction formed with the  
24 substrate is reverse biased. This isolates the diffused  
25 regions from one another.

26           A second method shown in FIG. 20 is to use a non-  
27 conductive substrate 150 and pattern a refractory metal such as  
28 tungsten 152 over it. The wafer is then thermally oxidized and  
29 nitride or other element material is deposited over it. The  
30 elements are then patterned and released as above.

31           In summary, the reflective, deformable grating light  
32 modulator or GLV is a device which exhibits high resolution (25  
33 by 8  $\mu\text{m}^2$  to 100  $\mu\text{m}^2$ ); high response times/large bandwidth (2 to

1 10 MHz); high contrast ratio (close to 100% modulation with a  
2 3V switching voltage); is polarization independent and easy to  
3 use. This device also has tolerance for high optical power,  
4 has good optical throughput, is simple to manufacture,  
5 semiconductor-processing compatible, and has application in a  
6 wide range of fields including use as an SLM and with fiber  
7 optic technology.

8 As generally described above, and as depicted in  
9 simplistic fashion in FIG. 21 of the drawing, a combination of  
10 GLVs can be used to provide a visual display by exploiting the  
11 grating dispersion of white light to isolate the three primary  
12 color components of each pixel in a color display system. This  
13 type of schlieren optical system employs an array 160 of pixel  
14 units 161, each including three subpixel grating components  
15 (162, 164, 166) respectively having different grating periods  
16 selected to diffract red, green and blue spectral illumination  
17 from a white light source 168 through a slit 169 placed at a  
18 specific location relative to the source and the array. For  
19 each pixel unit in the array only a small but different part of  
20 the optical spectrum will be directed by each of the three  
21 subpixel components of each pixel unit through the slit 169 to  
22 the viewer. As a result, the three color constituents of each  
23 pixel unit will be integrated by the viewer's eye so that the  
24 viewer perceives a color image that spans the face of the  
25 entire array 160. In this implementation, all of the subpixel  
26 components have gratings with beam-like elements that are  
27 oriented in the same direction. The optical system can thus be  
28 analyzed in a single plane that passes through the source 168,  
29 the center of the pixel unit 161 under consideration, and the  
30 center of the viewer's pupil. Suitable lenses (not shown)  
31 could also be used to ensure that the light diffracted and  
32 reflected from the array is focused onto the plane of the slit

1 (aperture) and that the pixel plane is imaged onto the viewer's  
2 retina or onto a projection screen.

3 The array could be implemented to include fixed grating  
4 elements fabricated using photolithographic techniques to in  
5 effect "program" each pixel unit. Alternatively, the array 160  
6 can be implemented as an active device in which appropriately  
7 routed address lines extend to each subpixel so that each such  
8 subpixel can be dynamically programmed by the application of  
9 suitable voltages to the subpixel components as described  
10 above.

11 It should also be noted that whereas three subpixel  
12 components are needed for generating a full-color pixel unit,  
13 only two subpixel components are needed to generate a multi-  
14 colored pixel, *i.e.*, a pixel that can display a first color, a  
15 second color, a third color which is a combination of the first  
16 and second colors, or no color.

17 In an embodiment depicted in FIG. 22, instead of varying  
18 the periods of the gratings and using a white light source to  
19 generate color, each pixel unit is comprised of three subpixel  
20 grating components of substantially equal period but of  
21 different angular orientation, and each subpixel component is  
22 operatively combined with one of three primary color light  
23 sources. More particularly, the array 170 includes a plurality  
24 of pixel units 171, each of which is comprised of subpixel  
25 components 172, 174 and 176, oriented at  $120^\circ$  angles relative  
26 to each other. At least three monochromatic light sources are  
27 then positioned and trained on the array such that when a  
28 corresponding subpixel component of any pixel unit is in its  
29 diffraction mode, it will cause light from a particular source  
30 to be diffracted and directed through a viewing aperture. Red  
31 light from a red source 178 might for example be diffracted  
32 from subpixel component 172 and directed through aperture 184;  
33 blue light generated by a source 180 might be diffracted by a

1 subpixel component 176 through aperture 184; and green light  
2 from a source 182 might be diffracted by a subpixel component  
3 174 and directed through the opening 184 to the viewer's pupil.

4 This system is an improvement over previously described  
5 implementations requiring a slit, because the viewing aperture  
6 184 can be widened significantly, for example, at least 10X.  
7 Suitable lenses (not shown) could also be used in the  
8 embodiments of FIGS. 21 and 22 to ensure that the light  
9 diffracted and reflected from the array focuses onto the plane  
10 of the slit (aperture) and that the pixel plane is imaged onto  
11 the viewer's retina or onto a projection screen.

12 The GLV layout of array 170 is more clearly depicted in  
13 FIG. 23 wherein sets of the three rhombus-configured subpixel  
14 components 172, 174 and 176 are collectively joined to form  
15 hexagonal pixel units 171 which can be tiled into a silicon  
16 chip array with a 100% filling factor. The grating elements of  
17 the three subpixel components 172, 174 and 176 are oriented 120  
18 ° relative to each other as depicted and, except for the  
19 rhombus-shaped grating in the outer boundary, all have grating  
20 elements configured as described above.

21 Other angular separations of subpixel gratings can also  
22 be chosen, as depicted in FIGS. 24, 25 and 26. In FIG. 24, an  
23 alternative three-component pixel unit 200 is illustrated,  
24 including three subpixel components 202, 204, and 206 aligned  
25 in a row and including grating elements which have relative  
26 angular separations of vertical, horizontal and 45°. While  
27 this configuration does not have the uniform grating element  
28 length advantage of the previous embodiment, it is based on the  
29 conventional rectangular coordinate system and is easier to  
30 manufacture than other embodiments. There are some possible  
31 GLV implementations, such as one in which an underlying mirror

1 is the movable element rather than the grating elements, for  
2 which this design would be excellent.

3 A hybrid compromise scheme is to use angular orientation  
4 to distinguish between red-green and green-blue. Red and blue  
5 would still be distinguished by their different grating  
6 periods. In this scheme, the slit or aperture can be made  
7 significantly wider (by a factor of approximately 2).

8 Exemplary layouts of such schemes are shown in FIGS. 25 and 26.

9 In FIG. 25, note that there are twice as many green subpixel  
10 components (210) as red (212) and blue (214) subpixel  
11 components. This would actually be desirable in certain small  
12 direct-view devices, since LEDs would be used as the mono-  
13 chromatic illumination sources. Presently, red and blue LEDs  
14 are much brighter than green LEDs, thus one would want to  
15 design the display with more green area to compensate and have  
16 the colors balance.

17 The layout depicted in FIG. 26 has equal numbers of red,  
18 green and blue subpixels. Three subpixel components can be  
19 combined into one L-shaped, full color pixel unit. An  
20 advantage of both of these systems is that they use right-angle  
21 geometry, thereby simplifying design.

22 Referring now to FIG. 27, an actual implementation of a  
23 small communication apparatus embodying the present invention  
24 is depicted at 220. The device includes a housing 222 about  
25 the size of that of a standard telephone pager. As  
26 illustrated, the housing 222 is partially broken away to reveal  
27 a viewing aperture 224 and the various internal components  
28 comprising a GLV chip 226, including an array of pixel units  
29 having subpixel grating components as described above, a  
30 suitable support and lead frame structure 228 for supporting  
31 the chip 226 and providing addressable electrical connection to  
32 each grating thereof, an electronic module 230 for receiving  
33 communicated data and generating drive signals for input to the

1 chip 226, a red LED 232, a blue LED 234, and a pair of green  
2 LEDs 236 and 238, an LED-powering module 240, and a power  
3 supply battery 242. As suggested above with regard to FIGS. 21  
4 and 22, appropriate lenses (not shown) may also be included.

5 The relative positioning of the LEDs 232-238 is of course  
6 determined by the grating configuration as suggested above.  
7 Two green LEDs are used in this embodiment to ensure that the  
8 green light output is roughly equivalent to the output  
9 intensity of the red and blue light sources. In the preferred  
10 embodiment, a typical distance between the chip 226 and the  
11 aperture 224 might be on the order of 2-10cm, the aperture 224  
12 might have a diameter in the range of 3mm-1.5cm, and suitable  
13 lens structures may be used in association with the LEDs, the  
14 chip face and/or the aperture.

15

16 In the embodiment depicted in FIG. 28, instead of using a  
17 white light source to generate color, each subpixel component  
18 is operatively combined with one of three primary color light  
19 sources. More particularly, the array 250 includes a plurality  
20 of pixel units 251, each of which is comprised of three  
21 subpixel components 252, 254, and 256 having gratings with  
22 beam-like elements that are oriented in the same direction. At  
23 least three monochromatic light sources 258, 260, and 262 are  
24 positioned and trained on the array. The sources and the  
25 aperture 264 are coplanar. Each of the three subpixel  
26 components (252, 254, and 256) has a different grating period  
27 selected to cause light from a particular source (258, 260, and  
28 262 respectively) to be diffracted and directed through the  
29 aperture 264 to the viewer when such subpixel component is in  
30 its diffraction mode. For example, blue light from a blue  
31 source 258 might be diffracted from subpixel component 252 and  
32 directed through aperture 264, green light generated by a  
33 source 260 might be diffracted from subpixel component 254

1 through aperture 264, and red light from a source 262 might be  
2 diffracted from subpixel component 256 through the opening 264  
3 to the viewer's pupil. This implementation is an improvement  
4 over previously described implementations using a white light  
5 source and a slit, because fewer grating elements are required  
6 to generate color, the dimensions of the grating elements are  
7 less critical, the aperture can be significantly larger than  
8 the slit and the viewing angle can be widened significantly,  
9 for example, at least 3X. Suitable lenses (not shown) could  
10 also be used in this embodiment to ensure that the light  
11 diffracted and reflected from the array focuses onto the plane  
12 of the aperture and that the pixel plane is imaged onto the  
13 viewer's retina or onto a projection screen.

14 It should be noted that in the embodiments of FIGS. 21  
15 through 28 whereas three subpixel components and at least three  
16 sources having different colors are needed for generating a  
17 full-color pixel unit, only two subpixel components and two  
18 light sources are needed to generate a multi-colored pixel,  
19 i.e., a pixel that can display a first color, a second color, a  
20 third color which is a combination of the first and second  
21 colors, or no color.

22 In operation, data communicated to the device 220 will be  
23 received and processed by the module 230 and used to actuate  
24 the subpixel grating components in chip 226. Light diffracted  
25 from the pixel units of the GLV array will be directed through  
26 the aperture 224 to generate an image that can be viewed by the  
27 eye of an observer, input to a camera, or projected onto a  
28 screen. The image will be full color and can either be static  
29 for a fixed or selectable duration, or dynamic in that it  
30 changes with time and can even be a video-type image.

31 Although the actual implementation depicted is a pager-  
32 like communications viewer and can alternatively perform in a  
33 projection mode, it will be appreciated that the same technique

1 can be employed in a goggle application to provide a display  
2 for one or both eyes of a user. Moreover, by using two  
3 coordinated units, goggles can be provided for generating  
4 three-dimensional video images to create a virtual reality  
5 implementation. Quite clearly, such apparatus would also find  
6 utility as a viewing device for many remote manipulation,  
7 positioning and control applications.

8         Still another application of the present invention is to  
9 use the array of pixel units as a static information storage  
10 medium which can be "read out" by either sweeping a trio of  
11 colored layer beams across its surface, or by fixing the trio  
12 of light sources and moving the storage medium relative  
13 thereto, or by using any combination of moving lights and  
14 moving media.

15         Although the present invention has been described above  
16 in terms of specific embodiments, it is anticipated that  
17 alterations and modifications thereof will no doubt become  
18 apparent to those skilled in the art. It is therefore intended  
19 that the following claims be interpreted as covering all such  
20 alterations and modifications as fall within the true spirit  
21 and scope of the invention.

22         What is claimed is:

CLAIMS

1 1. Display apparatus for generating multi-colored optical  
2 images, comprising:  
3 housing means having an optical aperture through which  
4 light may be passed;  
5 light valve means disposed within said housing means and  
6 forming an array of discrete light-modulating pixel units, each  
7 including a plurality of subpixel components having elongated  
8 grating elements, the grating elements of at least two subpixel  
9 components of each pixel unit being oriented such that the  
10 grating elements of a first of said two subpixel components  
11 extend in a direction different from that of the grating  
12 elements of a second of said two subpixel components, each said  
13 subpixel component being adapted to selectively have a  
14 reflective state and a diffractive state; and  
15 a plurality of colored light sources respectively  
16 positioned to illuminate particular subpixel components of each  
17 pixel unit of said array such that no light reflected from any  
18 of said subpixel components in a reflective state passes  
19 through said aperture, but such that light diffracted from  
20 corresponding ones of said subpixel components of each said  
21 pixel unit in a diffractive state is directed through said  
22 aperture.

1 2. Display apparatus as recited in claim 1 wherein the  
2 grating elements of a first of said subpixel components of each  
3 said pixel unit have a first orientation and the grating  
4 elements of a second of said subpixel components of each said  
5 pixel unit have a second orientation which is at 90 degrees  
6 relative to the first orientation.

1 3. Display apparatus as recited in claim 2 wherein each said  
2 pixel unit has a third subpixel component, and wherein the  
3 grating elements of said third subpixel component of each said  
4 pixel unit have an orientation that is neither said first  
5 orientation nor said second orientation.

1 4. Display apparatus as recited in claim 3 wherein the  
2 grating periods of the grating elements of the three subpixel  
3 components of each pixel unit are equal.

1 5. Display apparatus as recited in claim 1 wherein the  
2 grating elements of the first of said subpixel components of  
3 each said pixel unit have a first orientation and a first  
4 grating period, wherein the grating elements of the second  
5 subpixel component of each said pixel unit have a second  
6 orientation which is at 90 degrees relative to the first  
7 orientation and said first grating period, and wherein the  
8 grating elements of a third subpixel component of each said  
9 pixel unit have said first orientation and a second grating  
10 period different from said first grating period.

1 6. Display apparatus as recited in claim 1 wherein the  
2 grating elements of the first subpixel component of each said  
3 pixel unit have a first angular orientation, wherein the  
4 grating elements of the second subpixel component of each said  
5 pixel unit have a second angular orientation relative to the  
6 grating elements of said first subpixel component, and wherein  
7 the grating elements of a third subpixel component of each said  
8 pixel unit have a third angular orientation relative to the  
9 angular orientations of the grating elements of said first and  
10 second subpixel components.

1 7. Display apparatus as recited in claim 6 wherein said  
2 first angular orientation, said second angular orientation and  
3 said third angular orientation are respectively separated by  
4 angles of  $120^\circ$ .

1 8. Display apparatus as recited in claim 7 wherein said  
2 first, second and third subpixel components each have rhombic  
3 perimetric boundaries and are positioned contiguous to each  
4 other, such that the collective perimetric boundary of each  
5 pixel unit has a generally hexagonal shape.

1 9. Display apparatus as recited in any one of claims 1-8  
2 wherein the grating elements of each said subpixel component  
3 are arranged parallel to each other, with the light-reflective  
4 surfaces of the grating elements normally lying in a first  
5 plane, and wherein each said subpixel component includes  
6 means for supporting alternate ones of the grating  
7 elements in a fixed position, and  
8 means for moving the remaining grating elements relative  
9 to the fixed grating elements and between a first configuration  
10 wherein all of the grating elements lie in the first plane and  
11 the subpixel component acts to reflect incident light as a  
12 plane mirror, and a second configuration wherein said remaining  
13 grating elements lie in a second plane parallel to the first  
14 plane and the subpixel component diffracts incident light as it  
15 is reflected from the planar surfaces of the grating elements.

1 10. Display apparatus as recited in claim 9 wherein said  
2 means for moving said remaining grating elements includes means  
3 for applying an electrostatic force to said remaining grating  
4 elements.

1 11. Display apparatus as recited in claim 9 and further  
2 comprising electronic communication means for receiving  
3 transmitted data and for generating signals for causing certain  
4 ones of said subpixel components to assume a reflective state  
5 and other ones of said subpixel components to assume a  
6 diffractive state.

1 12. Display apparatus for generating multi-colored optical  
2 images, comprising:  
3 housing means having an optical aperture through which  
4 light may be passed;  
5 light valve means disposed within said housing means and  
6 forming an array of discrete light-modulating pixel units each  
7 including a plurality of subpixel components having elongated  
8 grating elements, the grating elements of at least two subpixel  
9 components of each pixel unit being oriented such that the  
10 grating elements of a first of said two subpixel components  
11 extend in a direction different from that of the grating  
12 elements of a second of said two subpixel components, each said  
13 subpixel component being adapted to selectively have a  
14 reflective state and a diffractive state; and  
15 a plurality of colored light sources respectively  
16 positioned to illuminate particular subpixel components of each  
17 pixel unit of said array such that no light diffracted from any  
18 of said subpixel components in a diffractive state passes  
19 through said aperture, but such that light reflected from  
20 corresponding ones of said subpixel components of each said  
21 pixel unit in a reflective state is directed through said  
22 aperture.

1 13. Display apparatus as recited in claim 12 wherein the  
2 grating elements of the first of said subpixel components of

3 each said pixel unit have a first orientation and the grating  
4 elements of the second of said subpixel components of each said  
5 pixel unit have a second orientation which is at 90 degrees  
6 relative to the first orientation.

1 14. Display apparatus as recited in claim 13 wherein each  
2 said pixel unit has a third subpixel component, wherein the  
3 grating elements of said third subpixel component of each said  
4 pixel unit have an orientation that is neither said first  
5 orientation nor said second orientation.

1 15. Display apparatus as recited in claim 14 wherein the  
2 grating periods of the grating elements of the three subpixel  
3 components of each pixel unit are equal.

1 16. Display apparatus as recited in claim 12 wherein the  
2 grating elements of the first of said subpixel components of  
3 each said pixel unit have a first orientation and a first  
4 grating period, wherein the grating elements of the second  
5 subpixel component of each said pixel unit have a second  
6 orientation which is at 90 degrees relative to the first  
7 orientation and said first grating period, and wherein the  
8 grating elements of a third subpixel component of each said  
9 pixel unit have said first orientation and a second grating  
10 period different from said first grating period.

1 17. Display apparatus as recited in claim 12 wherein the  
2 grating elements of the first subpixel component of each said  
3 pixel unit have a first angular orientation, wherein the  
4 grating elements of the second subpixel component of each said  
5 pixel unit have a second angular orientation relative to the  
6 grating elements of said first subpixel component, and wherein  
7 the grating elements of a third subpixel component of each said

8 pixel unit have a third angular orientation relative to the  
9 angular orientations of the grating elements of said first and  
10 second subpixel components.

1 18. Display apparatus as recited in claim 17 wherein said  
2 first angular orientation, said second angular orientation and  
3 said third angular orientation are respectively separated by  
4 angles of  $120^\circ$ .

1 19. Display apparatus as recited in claim 18 wherein said  
2 first, second and third subpixel components each have rhombic  
3 perimetric boundaries and are positioned contiguous to each  
4 other, such that the collective perimetric boundary of each  
5 pixel unit has a generally hexagonal shape.

1 20. Display apparatus as recited in any one of claims 12-19  
2 wherein the grating elements of each said subpixel component  
3 are arranged parallel to each other, with the light-reflective  
4 surfaces of the grating elements normally lying in a first  
5 plane, and wherein each said subpixel component includes  
6 means for supporting alternate ones of the grating  
7 elements in a fixed position, and  
8 means for moving the remaining grating elements relative  
9 to the fixed grating elements and between a first configuration  
10 wherein all of the grating elements lie in the first plane and  
11 the subpixel component acts to reflect incident light as a  
12 plane mirror, and a second configuration wherein said remaining  
13 grating elements lie in a second plane parallel to the first  
14 plane and the subpixel component diffracts incident light as it  
15 is reflected from the planar surfaces of the grating elements.

1 21. Display apparatus as recited in claim 20 wherein said  
2 means for moving said remaining grating elements includes means

3 for applying an electrostatic force to said remaining grating  
4 elements.

1 22. Display apparatus as recited in claim 20 and further  
2 comprising electronic communication means for receiving  
3 transmitted data and for generating signals for causing certain  
4 ones of said subpixel components to assume a reflective state  
5 and other ones of said subpixel components to assume a  
6 diffractive state.

1 23. Apparatus for generating a multi-colored optical image,  
2 comprising:  
3 means forming an optical aperture through which light may  
4 be passed;  
5 means forming an array of discrete light-modulating pixel  
6 units, each including a plurality of subpixel components having  
7 elongated grating elements, the grating elements of at least  
8 two subpixel components of each said pixel unit being oriented  
9 such that the grating elements of a first of said two subpixel  
10 components extend in a direction different from that of the  
11 grating elements of a second of said two subpixel components,  
12 each said subpixel component having a fixed configuration,  
13 wherein said subpixel component either completely reflects  
14 incident light, completely diffracts incident light, or  
15 partially diffracts and partially reflects incident light; and  
16 a plurality of colored light sources respectively  
17 positioned to simultaneously illuminate at least one pixel unit  
18 of said array such that no light reflected from any illuminated  
19 subpixel component in a reflective state passes through said  
20 aperture, but such that light diffracted from any illuminated  
21 subpixel component in a diffractive state is directed through  
22 said aperture.

1 24. Apparatus for generating a multi-colored optical image,  
2 comprising:

3 means forming an optical aperture through which light may  
4 be passed;

5 means forming an array of discrete light-modulating pixel  
6 units, each including a plurality of subpixel components having  
7 elongated grating elements, the grating elements of at least  
8 two subpixel components of each said pixel unit being oriented  
9 such that the grating elements of a first of said two subpixel  
10 components extend in a direction different from that of the  
11 grating elements of a second of said two subpixel components,  
12 each said subpixel component having a fixed configuration in  
13 either a reflective state or a refractive state, wherein said  
14 subpixel component either completely reflects incident light,  
15 completely diffracts incident light, or partially diffracts and  
16 partially reflects incident light; and

17 a plurality of colored light sources respectively  
18 positioned to simultaneously illuminate at least one pixel unit  
19 of said array such that no light diffracted from any  
20 illuminated subpixel component in a diffractive state passes  
21 through said aperture, but such that light reflected from any  
22 illuminated subpixel component in a reflective state is  
23 directed through said aperture.

1 25. Apparatus as recited in claim 23 or 24 wherein the  
2 grating elements of the first of said subpixel components of  
3 each said pixel unit have a first orientation and the grating  
4 elements of the second of said subpixel components of each said  
5 pixel unit have a second orientation which is at 90 degrees  
6 relative to the first orientation.

1 26. Apparatus as recited in claim 25 wherein each said pixel  
2 unit has a third subpixel component, wherein the grating

3 elements of said third subpixel component of each said pixel  
4 unit have an orientation that is neither said first orientation  
5 nor said second orientation.

1 27. Apparatus as recited in claim 26 wherein the grating  
2 periods of the grating elements of the three subpixel  
3 components of each pixel unit are equal.

1 28. Apparatus as recited in claim 23 or 24 wherein the  
2 grating elements of the first of said subpixel components of  
3 each said pixel unit have a first orientation and a first  
4 grating period, wherein the grating elements of the second  
5 subpixel component of each said pixel unit have a second  
6 orientation which is at 90 degrees relative to the first  
7 orientation and said first grating period, and wherein the  
8 grating elements of a third subpixel component of each said  
9 pixel unit have said first orientation and a second grating  
10 period different from said first grating period.

1 29. Display apparatus as recited in claim 23 or 24 wherein  
2 the grating elements of the first subpixel component of each  
3 said pixel unit have a first angular orientation, wherein the  
4 grating elements of the second subpixel component of each said  
5 pixel unit have a second angular orientation relative to the  
6 grating elements of said first subpixel component, and wherein  
7 the grating elements of a third subpixel component of each said  
8 pixel unit have a third angular orientation relative to the  
9 angular orientations of the grating elements of said first and  
10 second subpixel components.

1 30. Display apparatus as recited in claim 29 wherein said  
2 first angular orientation, said second angular orientation and

3 said third angular orientation are respectively separated by  
4 angles of  $120^\circ$ .

1 31. Display apparatus as recited in claim 30 wherein said  
2 first, second and third subpixel components each have rhombic  
3 perimetric boundaries and are positioned contiguous to each  
4 other, such that the collective perimetric boundary of each  
5 pixel unit has a generally hexagonal shape.

1 32. A method of generating multi-colored optical images,  
2 comprising the steps of:

3 providing an optical aperture through which light may be  
4 passed;

5 forming an array of discrete light-modulating pixel  
6 units, each including a plurality of subpixel components having  
7 elongated grating elements, the grating elements of at least  
8 two subpixel components of each pixel unit being oriented such  
9 that the grating elements of a first of said two subpixel  
10 components extend in a direction different from that of the  
11 grating elements of a second of said two subpixel components,  
12 each said subpixel component being adapted to selectively have  
13 a reflective state and a diffractive state;

14 causing each said subpixel component to assume either  
15 said reflective state or said diffractive state; and

16 positioning a plurality of colored light sources to  
17 respectively illuminate particular subpixel components of each  
18 pixel unit of said array such that no light reflected from any  
19 of said subpixel components in a reflective state passes  
20 through said aperture, but such that light diffracted from  
21 subpixel components in a diffractive state is directed through  
22 said aperture, whereby an optical image corresponding to the  
23 states of said pixel units is viewable through said optical  
24 aperture.

1 33. A method as recited in claim 32 including causing the  
2 grating elements of the first of said subpixel components of  
3 each said pixel unit to have a first orientation and causing  
4 the grating elements of the second of said subpixel components  
5 of each said pixel unit to have a second orientation which is  
6 at 90 degrees relative to the first orientation.

1 34. A method as recited in claim 33 including causing each  
2 said pixel unit to have a third subpixel component, and causing  
3 the grating elements of said third subpixel component of each  
4 said pixel unit to have an orientation that is different from  
5 the orientations of said first and second subpixel components.

1 35. A method as recited in claim 34 and further including  
2 causing the grating periods of the grating elements of the  
3 three subpixel components of each pixel unit to be equal.

1 36. A method as recited in claim 32 including causing the  
2 grating elements of the first of said subpixel components of  
3 each said pixel unit to have a first orientation and a first  
4 grating period, causing the grating elements of the second  
5 subpixel component of each said pixel unit to have a second  
6 orientation which is at 90 degrees relative to the first  
7 orientation and said first grating period, and causing the  
8 grating elements of a third subpixel component of each said  
9 pixel unit to have said first orientation and a second grating  
10 period different from said first grating period.

1 37. A method as recited in claim 32 including causing the  
2 grating elements of the first subpixel component of each said  
3 pixel unit to have a first angular orientation, causing the  
4 grating elements of the second subpixel component of each said

5 pixel unit to have a second angular orientation relative to the  
6 grating elements of said first subpixel component, and causing  
7 the grating elements of a third subpixel component of each said  
8 pixel unit to have a third angular orientation relative to the  
9 angular orientations of the grating elements of said first and  
10 second subpixel components.

1 38. A method as recited in claim 37 wherein said first  
2 angular orientation, said second angular orientation and said  
3 third angular orientation are respectively separated by angles  
4 of  $120^\circ$ .

1 39. A method as recited in claim 38 and further including  
2 causing said first, second and third subpixel components to  
3 each have rhombic perimetric boundaries and to be positioned  
4 contiguous to each other, such that the collective perimetric  
5 boundary of each pixel unit has a generally hexagonal shape.

1 40. A method for generating multi-colored optical images,  
2 comprising the steps of:  
3 providing a housing means having an optical aperture  
4 through which light may be passed;  
5 disposing a light valve means disposed within said  
6 housing means and forming an array of discrete light-modulating  
7 pixel units, each including a plurality of subpixel components  
8 having elongated grating elements, the grating elements of at  
9 least two subpixel components of each pixel unit being oriented  
10 such that the grating elements of a first of said two subpixel  
11 components extend in a direction different from that of the  
12 grating elements of a second of said two subpixel components,  
13 each said subpixel component being adapted to selectively have  
14 a reflective state and a diffractive state; and

15 positioning a plurality of colored light sources to  
16 respectively illuminate particular subpixel components of each  
17 pixel unit of said array such that no light reflected from any  
18 of said subpixel components in a reflective state passes  
19 through said aperture, but such that light diffracted from  
20 corresponding ones of said subpixel components of each said  
21 pixel unit in a diffractive state is directed through said  
22 aperture.

1 41. A method as recited in any one of claims 32-40 wherein  
2 the grating elements of each said subpixel component are  
3 arranged parallel to each other, with the light-reflective  
4 surfaces of the grating elements normally lying in a first  
5 plane, and further including  
6 supporting alternate ones of the grating elements in a  
7 fixed position, and  
8 moving the remaining grating elements relative to the  
9 fixed grating elements and between a first configuration  
10 wherein all of the grating elements lie in the first plane and  
11 the subpixel component acts to reflect incident light as a  
12 plane mirror, and a second configuration wherein said remaining  
13 grating elements lie in a second plane parallel to the first  
14 plane and the subpixel component diffracts incident light as it  
15 is reflected from the planar surfaces of the grating elements.

1 42. A method of generating multi-colored optical images,  
2 comprising the steps of:  
3 providing an optical aperture through which light may be  
4 passed;  
5 forming an array of discrete light-modulating pixel  
6 units, each including a plurality of subpixel components having  
7 elongated grating elements, the grating elements of at least  
8 two subpixel components of each pixel unit being oriented such

9 that the grating elements of a first of said two subpixel  
10 components extend in a direction different from that of the  
11 grating elements of a second of said two subpixel components,  
12 each said subpixel component being adapted to selectively have  
13 a reflective state and a diffractive state;

14 causing each said subpixel component to assume either  
15 said reflective state or said diffractive state; and

16 positioning a plurality of colored light sources to  
17 respectively illuminate particular subpixel components of each  
18 pixel unit of said array such that no light diffracted from any  
19 of said subpixel components in a diffractive state passes  
20 through said aperture, but such that light reflected from  
21 subpixel components in a reflective state is directed through  
22 said aperture, whereby an optical image corresponding to the  
23 states of said pixel units is viewable through said optical  
24 aperture.

1 43. A method as recited in claim 42 including causing the  
2 grating elements of the first of said subpixel components of  
3 each said pixel to have a first orientation and causing the  
4 grating elements of the second of said subpixel components of  
5 each said pixel unit to have a second orientation which is at  
6 90 degrees relative to the first orientation.

1 44. A method as recited in claim 43 including causing each  
2 said pixel unit to have a third subpixel component, and causing  
3 the grating elements of said third subpixel component of each  
4 said pixel unit to have an orientation that is different from  
5 the orientations of said first and second subpixel components.

1 45. A method as recited in claim 44 and further including  
2 causing the grating periods of the grating elements of the  
3 three subpixel components of each pixel unit to be equal.

1 46. A method as recited in claim 42 including causing the  
2 grating elements of the first of said subpixel components of  
3 each said pixel unit to have a first orientation and a first  
4 grating period, causing the grating elements of the second  
5 subpixel component of each said pixel unit to have a second  
6 orientation which is at 90 degrees relative to the first  
7 orientation and said first grating period, and causing the  
8 grating elements of a third subpixel component of each said  
9 pixel unit to have said first orientation and a second grating  
10 period different from said first grating period.

1 47. A method as recited in claim 42 including causing the  
2 grating elements of the first subpixel component of each said  
3 pixel unit to have a first angular orientation, causing the  
4 grating elements of the second subpixel component of each said  
5 pixel unit to have a second angular orientation relative to the  
6 grating elements of said first subpixel component, and causing  
7 the grating elements of a third subpixel component of each said  
8 pixel unit to have a third angular orientation relative to the  
9 angular orientations of the grating elements of said first and  
10 second subpixel components.

1 48. A method as recited in claim 47 wherein said first  
2 angular orientation, said second angular orientation and said  
3 third orientation are respectively separated by angles of 120  
4 degrees.

1 49. A method as recited in claim 48 and further including  
2 causing said first, second and third subpixel components to  
3 each have rhombic perimetric boundaries and to be positioned  
4 contiguous to each other, such that the collective perimetric  
5 boundary of each pixel unit has a generally hexagonal shape.

1 50. A method for generating multi-colored optical images,  
2 comprising the steps of:  
3 providing a housing means having an optical aperture  
4 through which light may be passed;  
5 disposing a light valve means within said housing means  
6 and forming an array of discrete light-modulating pixel units,  
7 each including a plurality of subpixel components having  
8 elongated grating elements, the grating elements of at least  
9 two subpixel components of each pixel unit being oriented such  
10 that the grating elements of a first of said two subpixel  
11 components extend in a direction different from that of the  
12 grating elements of a second of said two subpixel components,  
13 each said subpixel component being adapted to selectively have  
14 a reflective state and a diffractive state; and  
15 positioning a plurality of colored light sources to  
16 respectively illuminate particular subpixel components of each  
17 pixel unit of said array such that no light diffracted from any  
18 of said subpixel components in a diffractive state passes  
19 through said aperture, but such that light reflected from  
20 corresponding ones of said subpixel components of each said  
21 pixel unit in a reflective state is directed through said  
22 aperture.

1 51. A method as recited in any one of claims 42-50 wherein  
2 the grating elements of each said subpixel component are  
3 arranged parallel to each other, with the light-reflective  
4 surfaces of the grating elements normally lying in a first  
5 plane, and further including  
6 supporting alternate ones of the grating elements in a  
7 fixed position, and  
8 moving the remaining grating elements relative to the  
9 fixed grating elements and between a first configuration

10 wherein all of the grating elements lie in a first plane and  
11 the subpixel component acts to reflect incident light as a  
12 plane mirror, and a second configuration wherein said remaining  
13 grating elements lie in a second plane parallel to the first  
14 plane and the subpixel component diffracts incident light as it  
15 is reflected from the planar surfaces of the grating elements.

1 52. Display apparatus for generating multi-colored optical  
2 images, comprising:

3 means forming an optical aperture through which light may  
4 be passed;

5 light valve means disposed with a predetermined  
6 relationship to said aperture and consisting of an array of  
7 discrete light-modulating pixel units, each including at least  
8 two subpixel components having elongated grating elements, each  
9 said subpixel component being adapted to selectively have a  
10 reflective state and a diffractive state; and

11 at least two different colored light sources positioned  
12 to illuminate the pixel units of said array,

13 the apparatus being characterized in that the grating  
14 elements of each subpixel component of each pixel unit  
15 selectively cause light from a particular source to be  
16 diffracted and directed through said aperture when in said  
17 diffractive state or to be reflected away from said aperture  
18 when in said reflective state.

1 53. Display apparatus for generating multi-colored optical  
2 images, comprising:

3 means forming an optical aperture through which light may  
4 be passed;

5 light valve means disposed with a predetermined  
6 relationship to said aperture and consisting of an array of  
7 discrete light-modulating pixel units, each including at least

8 two subpixel components having elongated grating elements, each  
9 said subpixel component being adapted to selectively have a  
10 reflective state and a diffractive state; and

11 at least two different colored light sources positioned  
12 to illuminate the pixel units of said array,

13 the apparatus being characterized in that the grating  
14 elements of each subpixel component of each pixel unit  
15 selectively cause light from a particular source to be  
16 reflected through said aperture when in said reflective state  
17 or to be diffracted and directed away from said aperture when  
18 in said diffractive state.

1 54. Display apparatus for generating multi-colored optical  
2 images, comprising:

3 means forming an optical aperture through which light may  
4 be passed;

5 light valve means disposed with a predetermined  
6 relationship to said aperture and consisting of an array of  
7 discrete light-modulating pixel units, each including at least  
8 two subpixel components having elongated grating elements, each  
9 said subpixel component being configured to have either a  
10 reflective state or a diffractive state; and

11 at least two different colored light sources positioned  
12 to illuminate the pixel units of said array,

13 the apparatus being characterized in that the grating  
14 elements of each subpixel component of each pixel unit having  
15 said diffractive state cause light from a particular source to  
16 be diffracted and directed through said aperture and subpixel  
17 components having said reflective state cause light from the  
18 particular source to be reflected away from said aperture.

1 55. Display apparatus as recited in any one of claims 52-54  
2 wherein the grating elements of each subpixel component extend

3 in a different direction relative to the grating elements of  
4 the other subpixel components of the same pixel unit.

1 56. Display apparatus as recited in any one of claims 52-54  
2 wherein the subpixel components of each pixel unit have  
3 different grating periods.

1/13

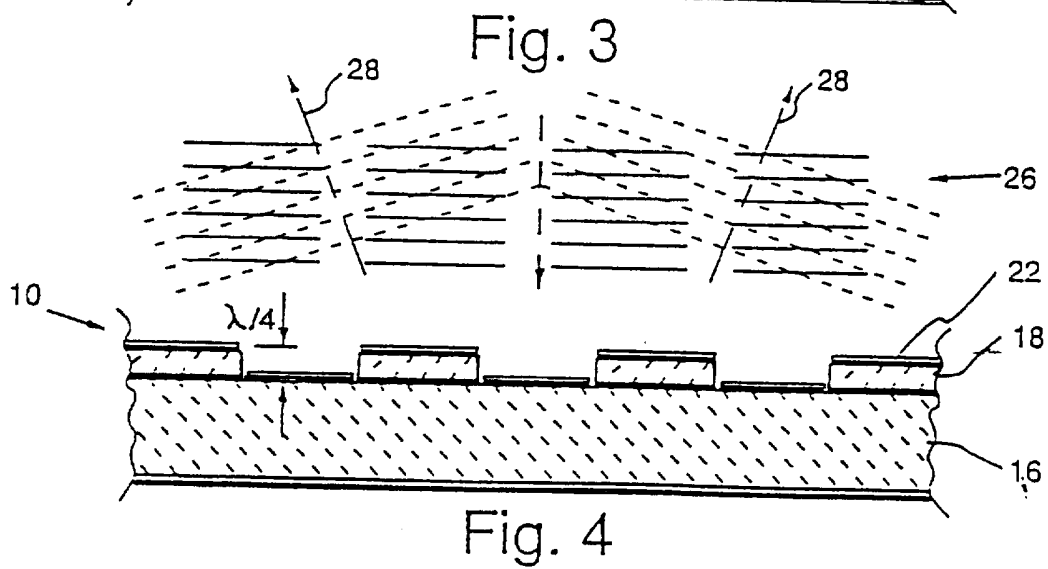
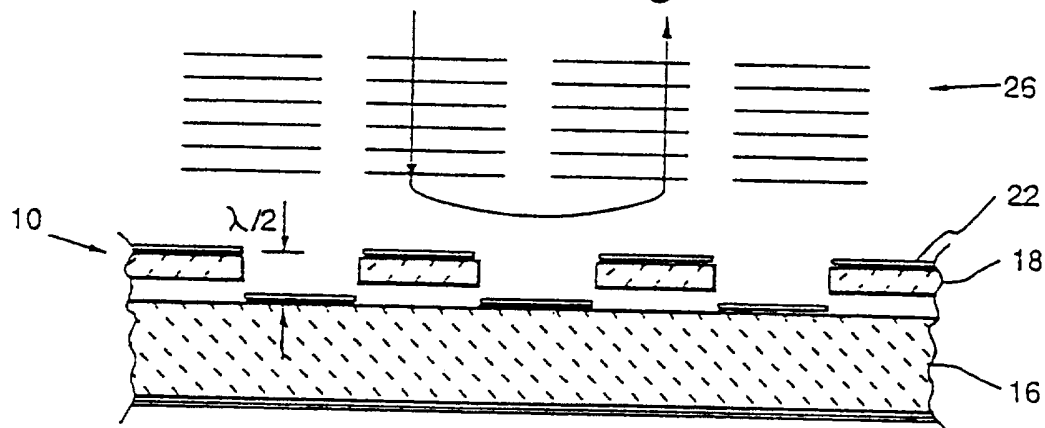
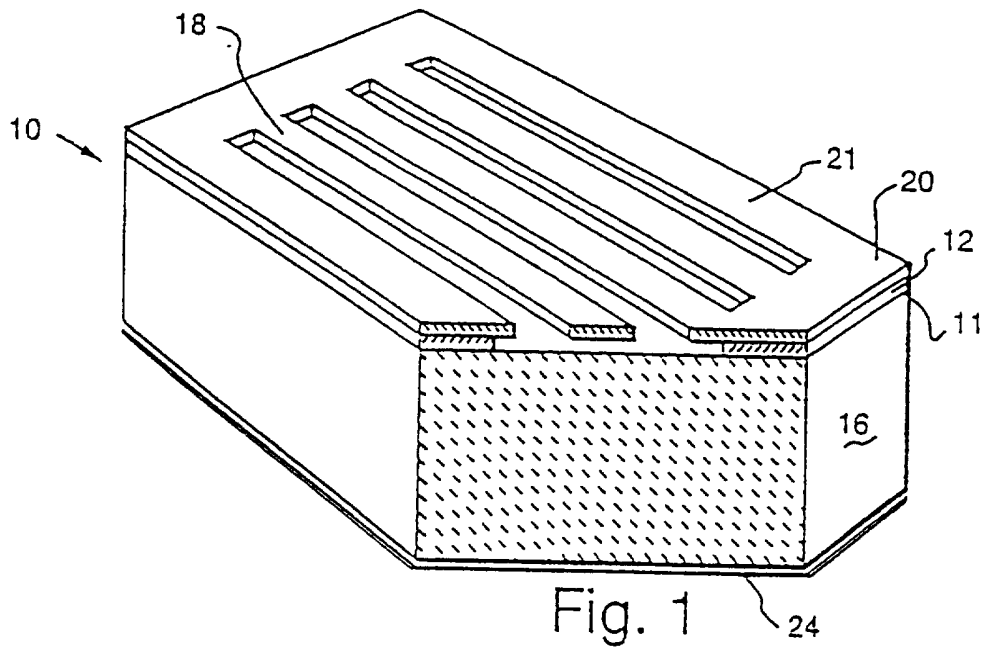

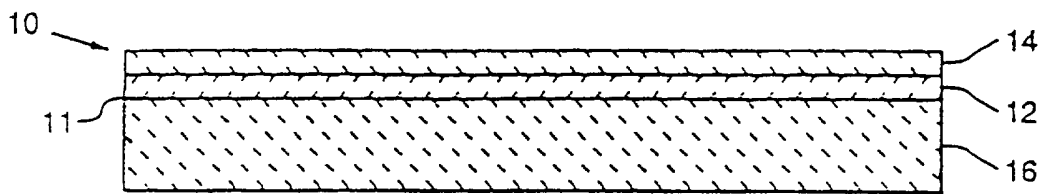

Fig. 2(a)

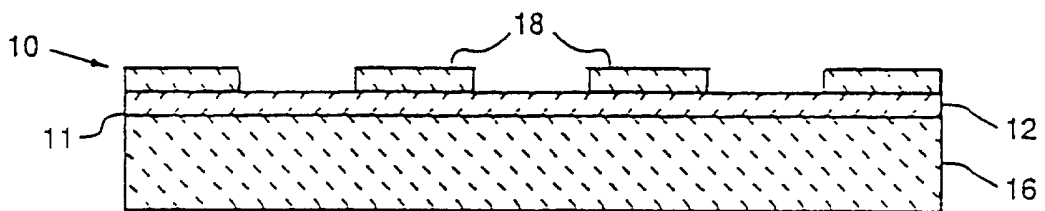

Fig. 2(b)

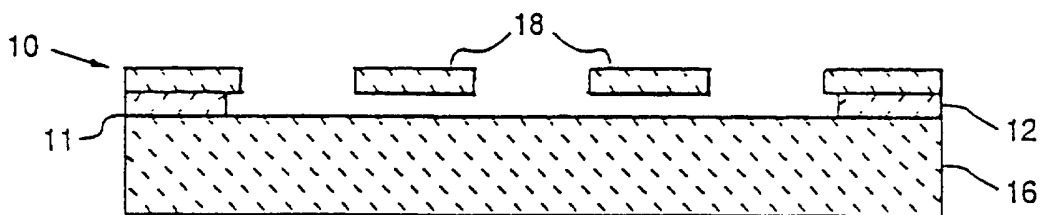

Fig. 2(c)

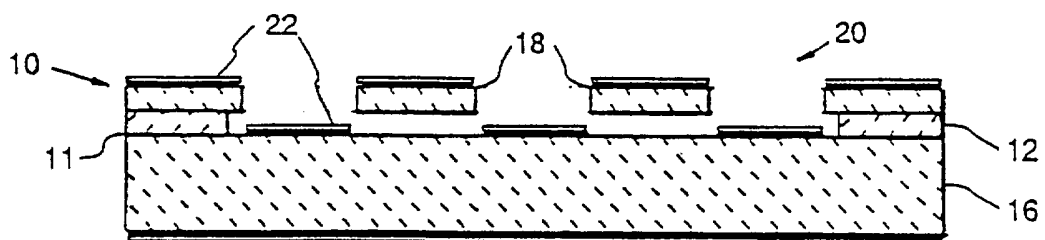

Fig. 2(d)

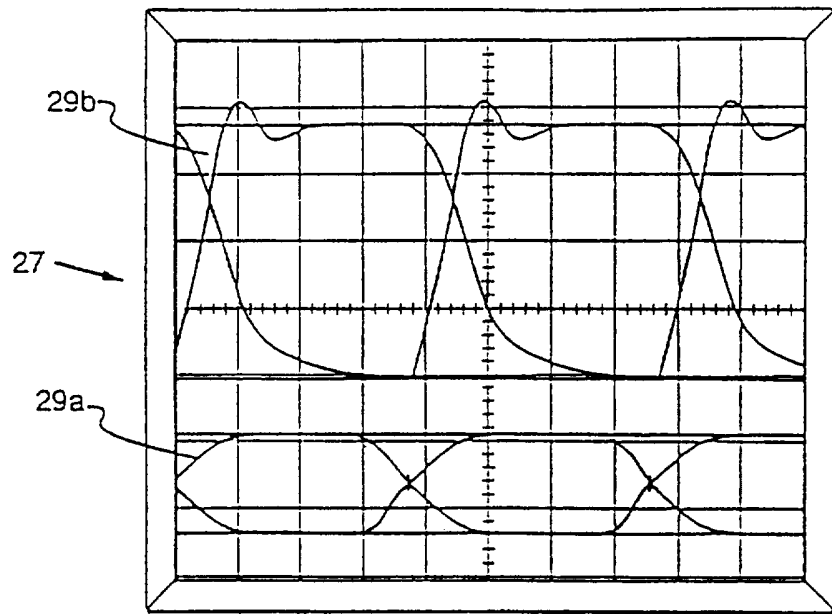

Fig. 5

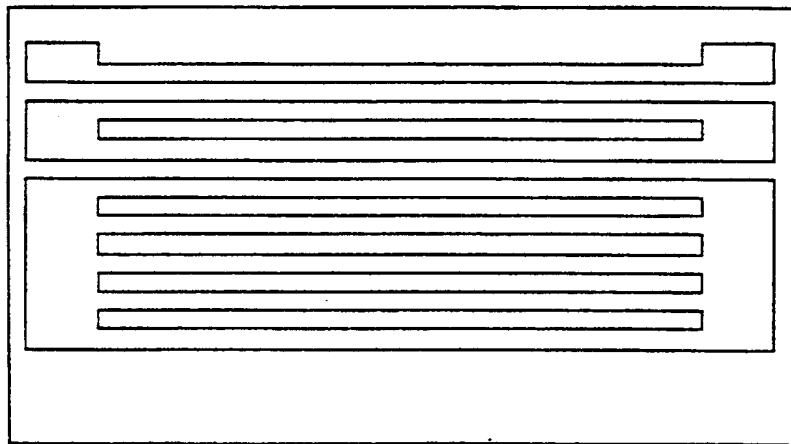

Fig. 6

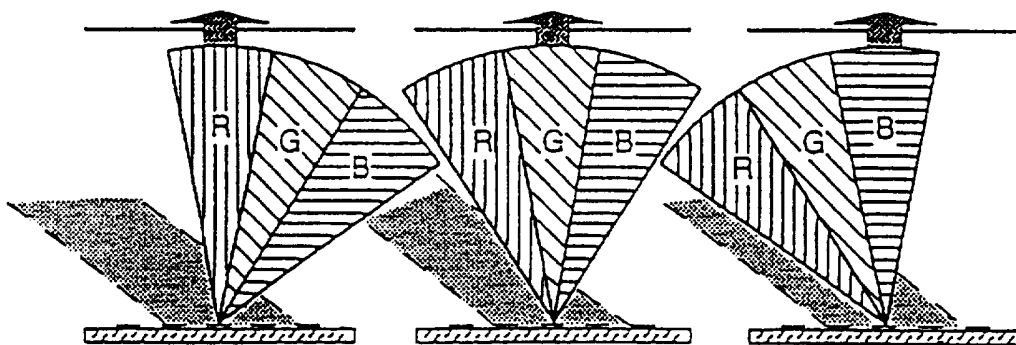

Fig. 7



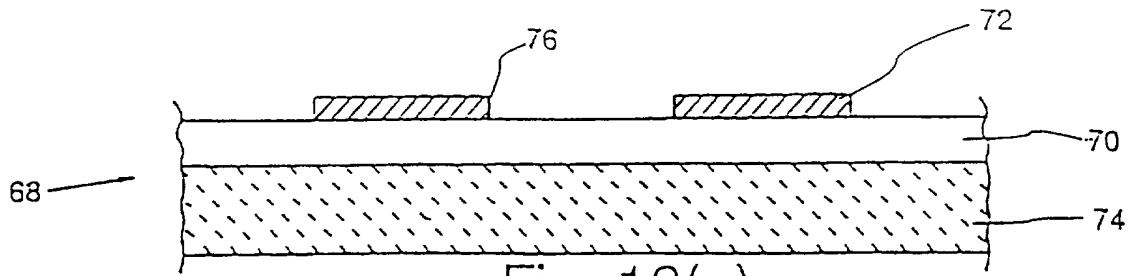

Fig. 12(a)

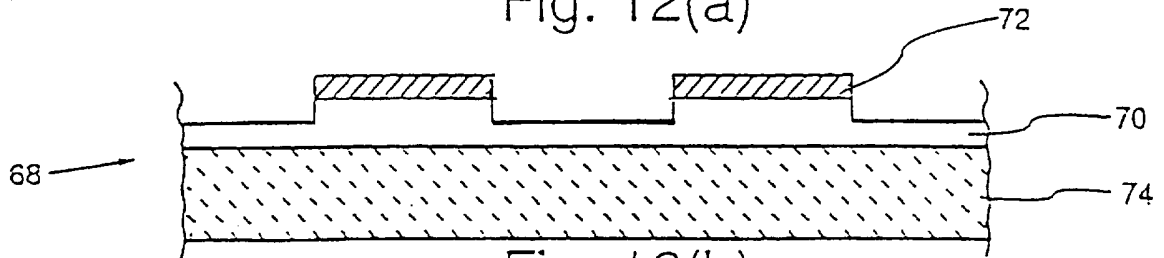

Fig. 12(b)

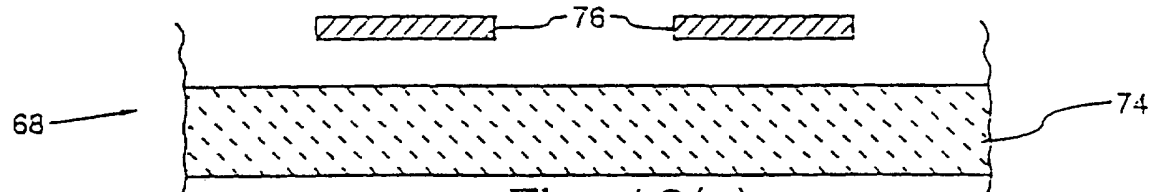

Fig. 12(c)

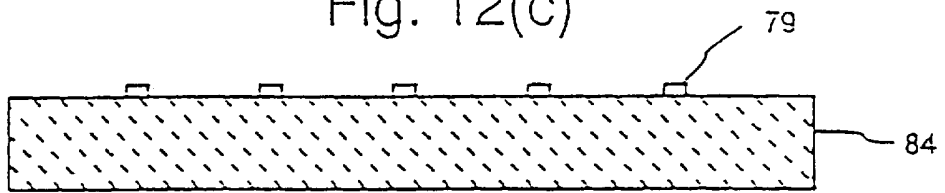

Fig. 13(a)

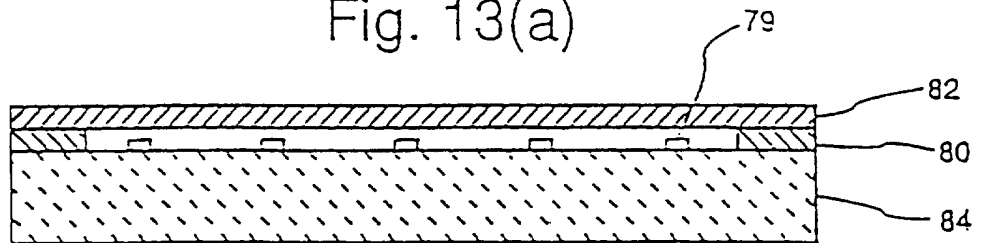

Fig. 13(b)

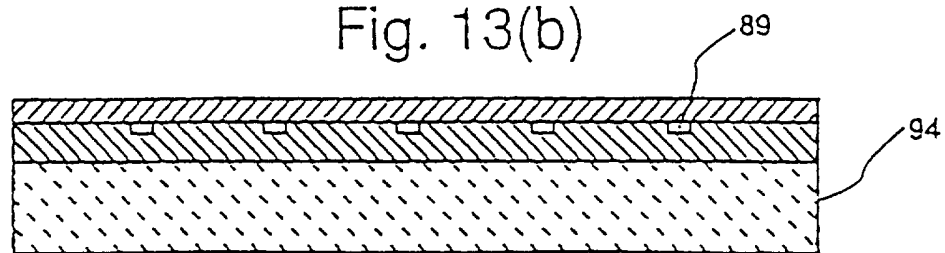

Fig. 14(a)

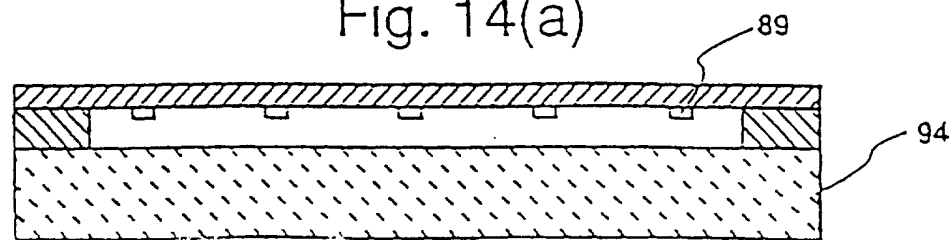

Fig. 14(b)

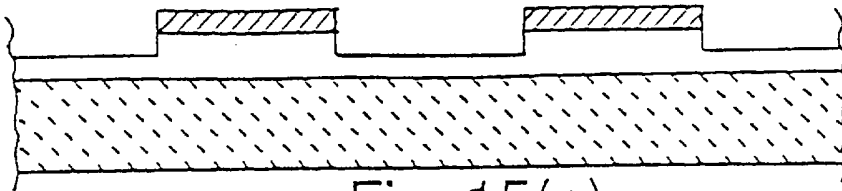

Fig. 15(a)

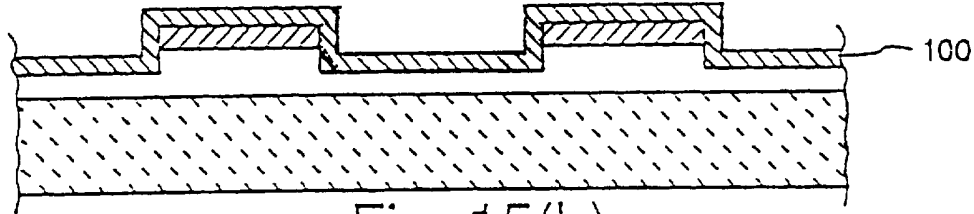

Fig. 15(b)

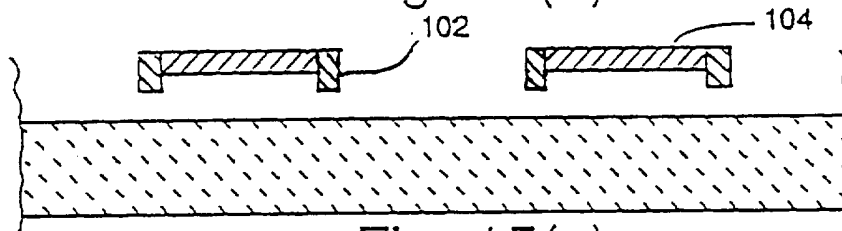

Fig. 15(c)

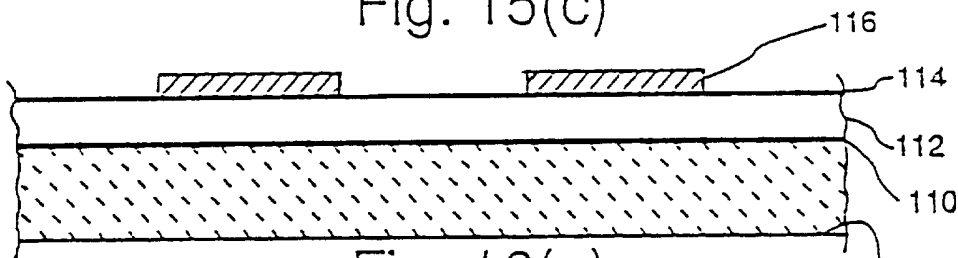

Fig. 16(a)

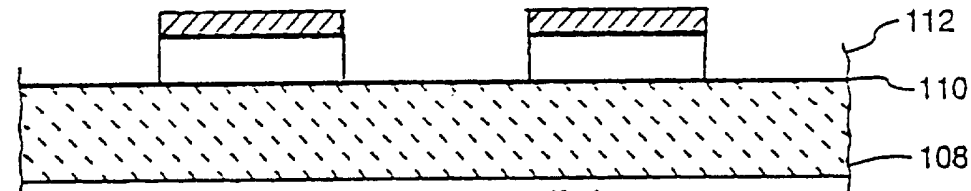

Fig. 16(b)

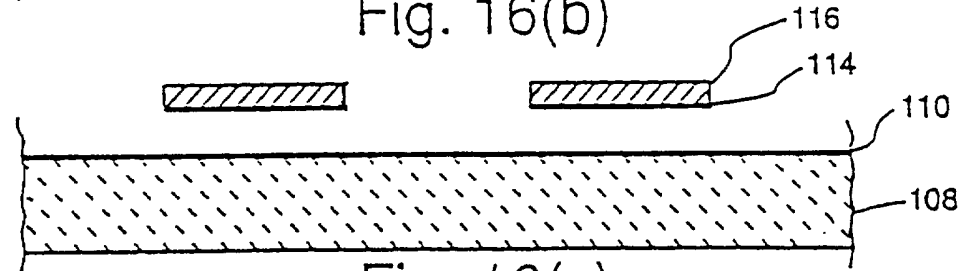

Fig. 16(c)

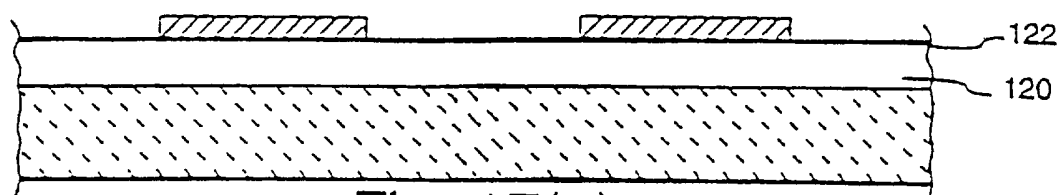

Fig. 17(a)

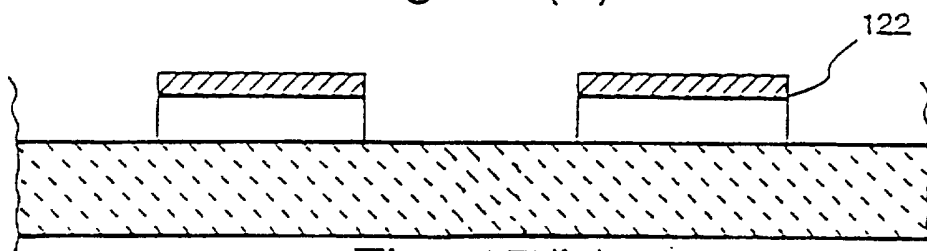

Fig. 17(b)

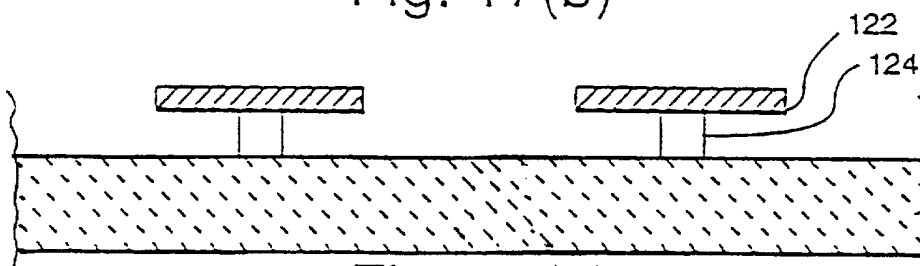

Fig. 17(c)

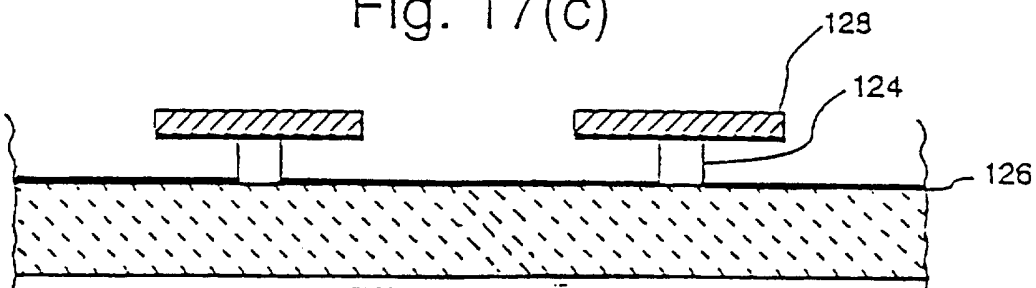

Fig. 17(d)

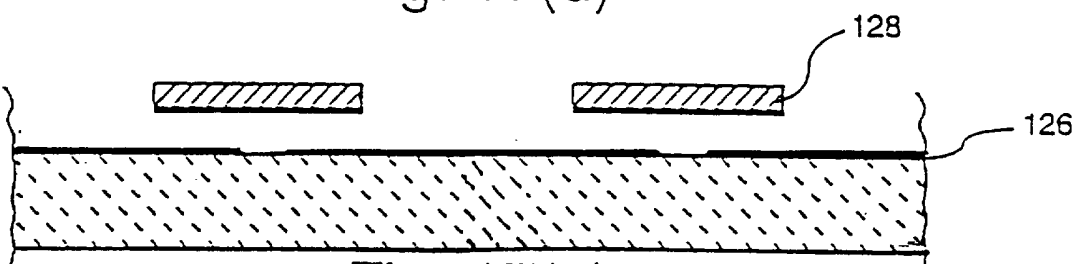

Fig. 17(e)

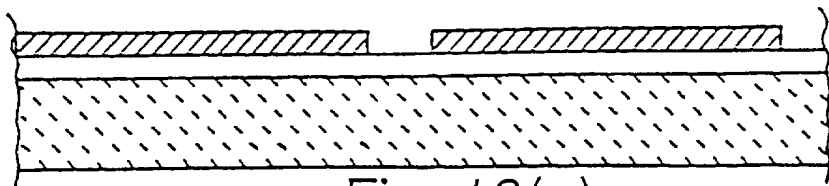

Fig. 18(a)

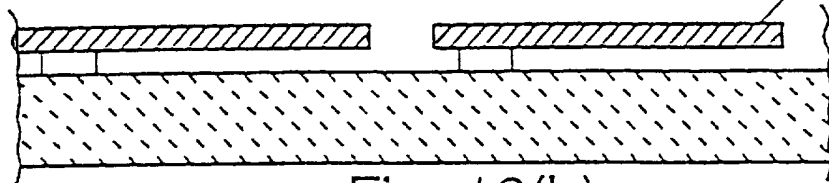

Fig. 18(b)

130



Fig. 19(a)

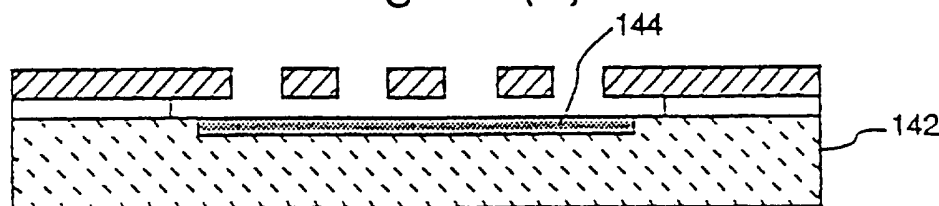

Fig. 19(b)

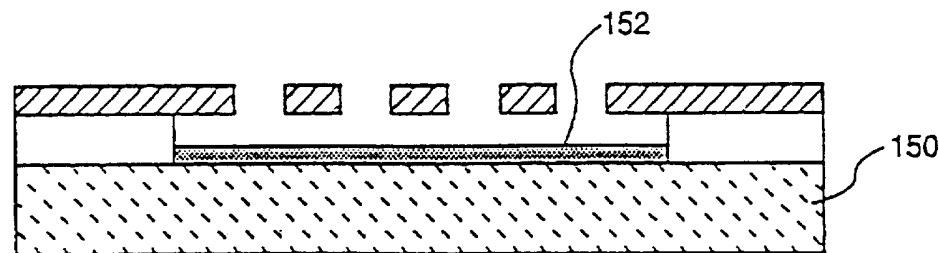
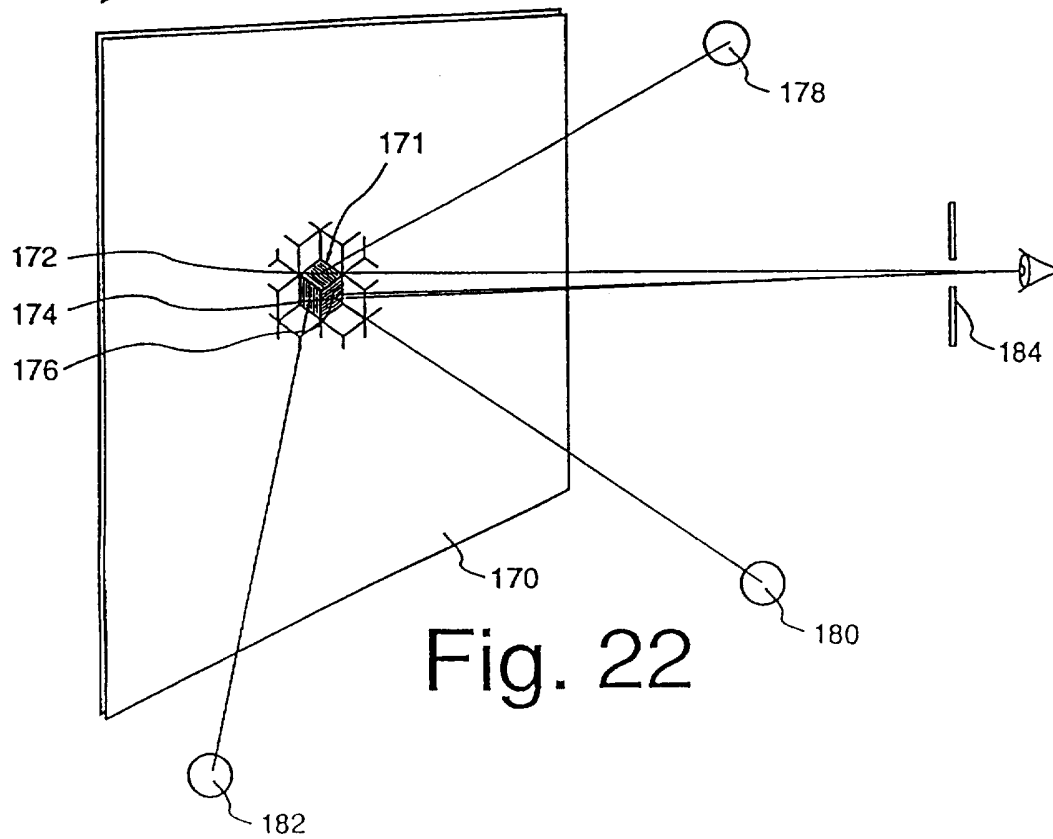
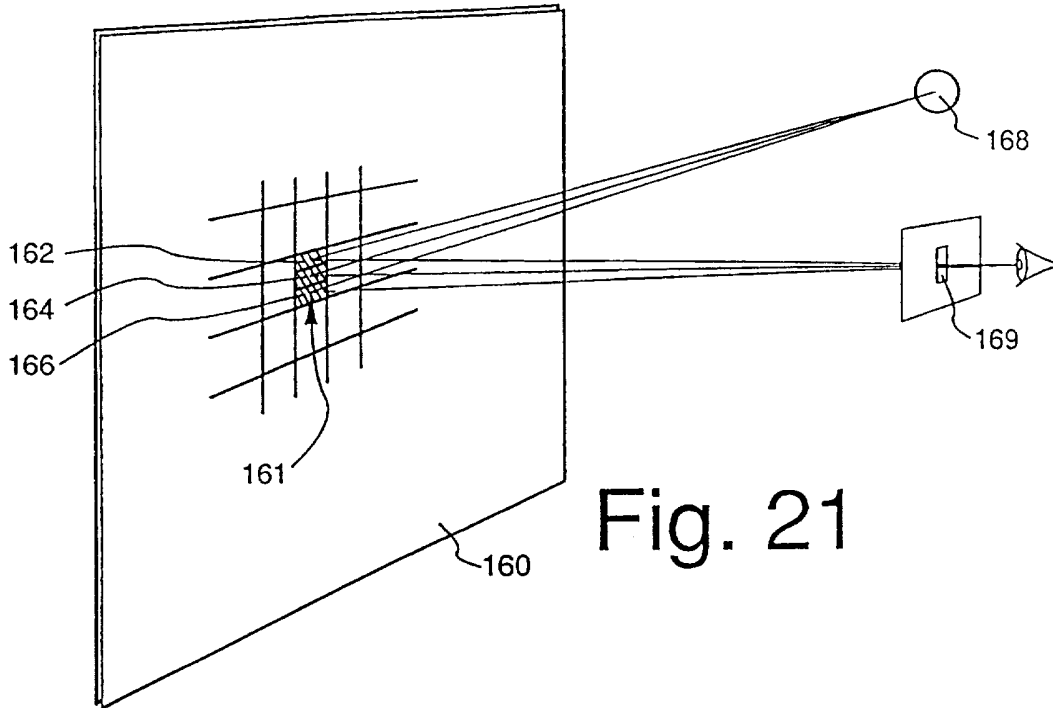

Fig. 20



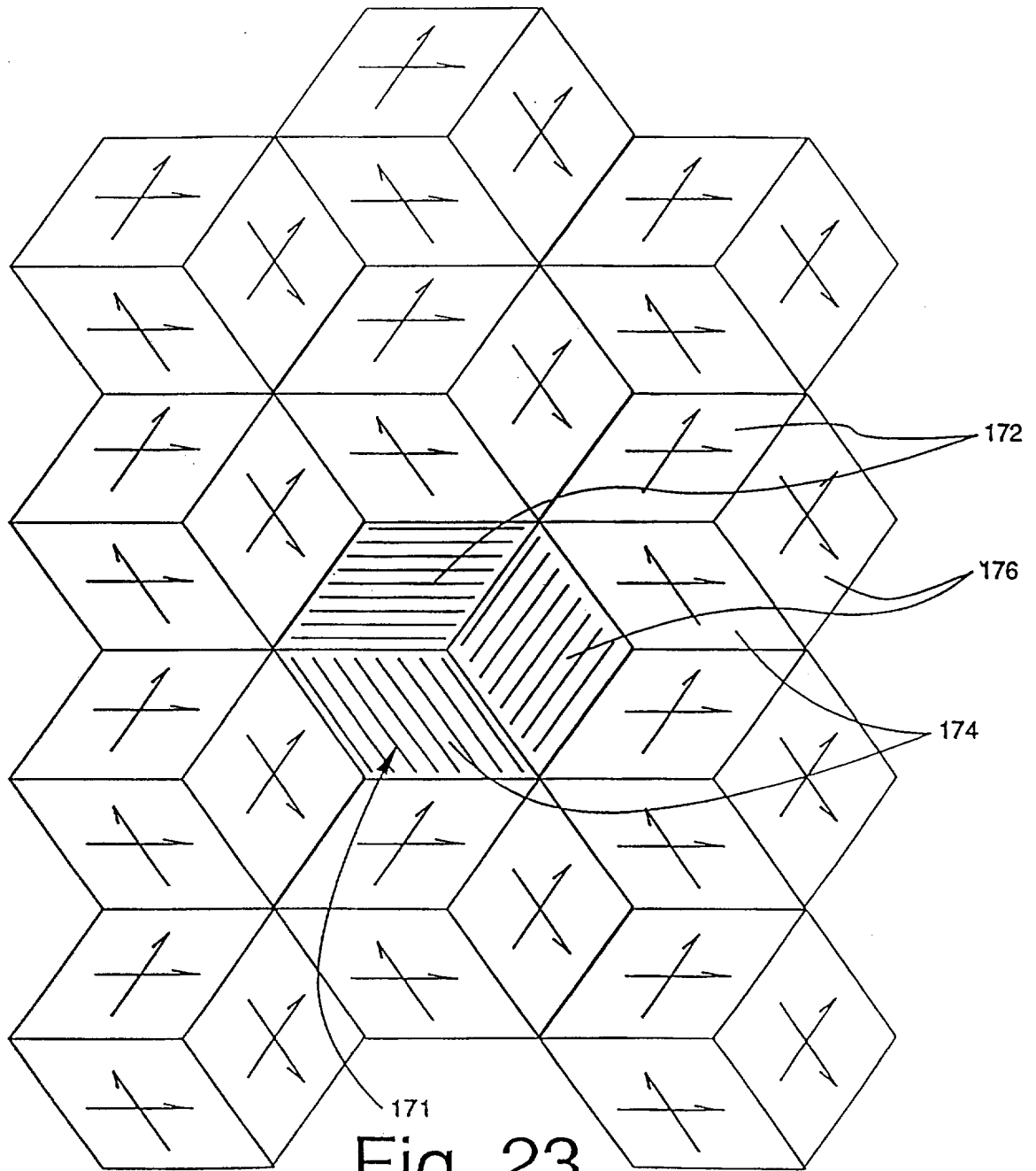

Fig. 23

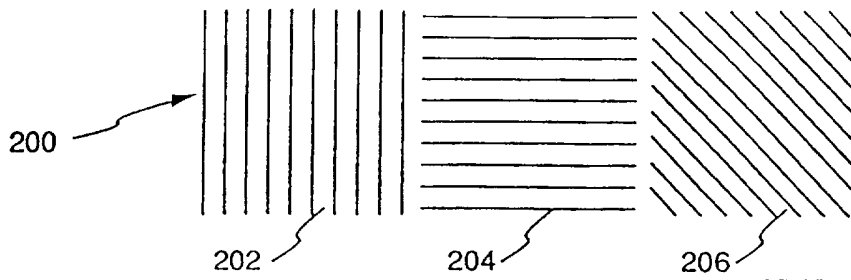

Fig. 24

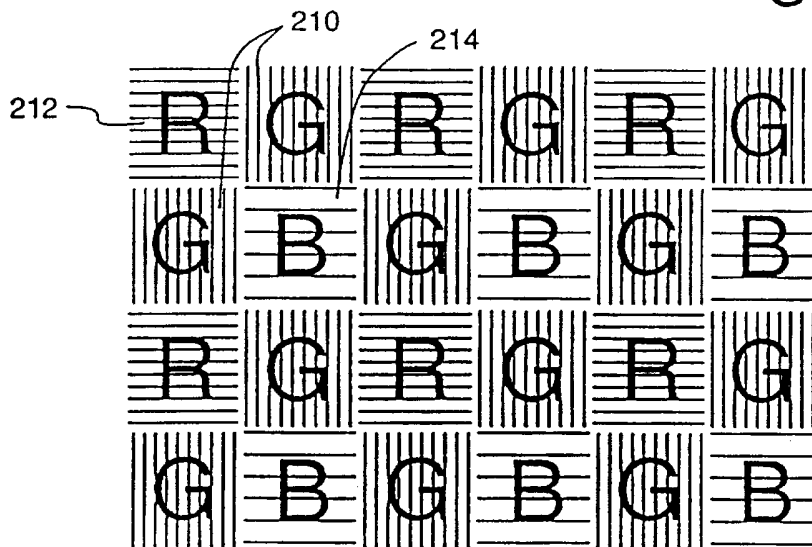

Fig. 25

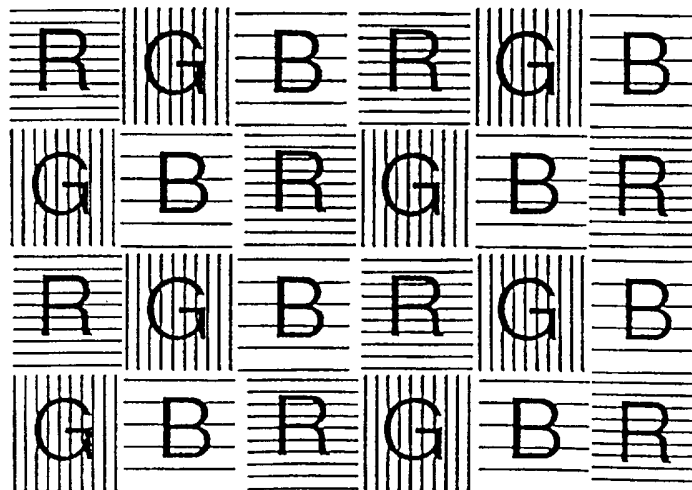

Fig. 26

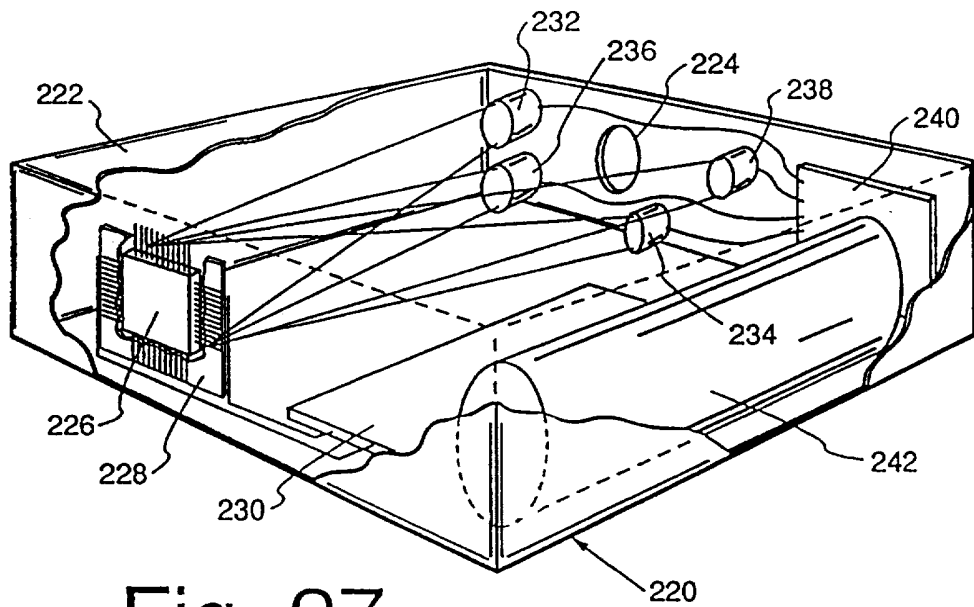

Fig. 27

