

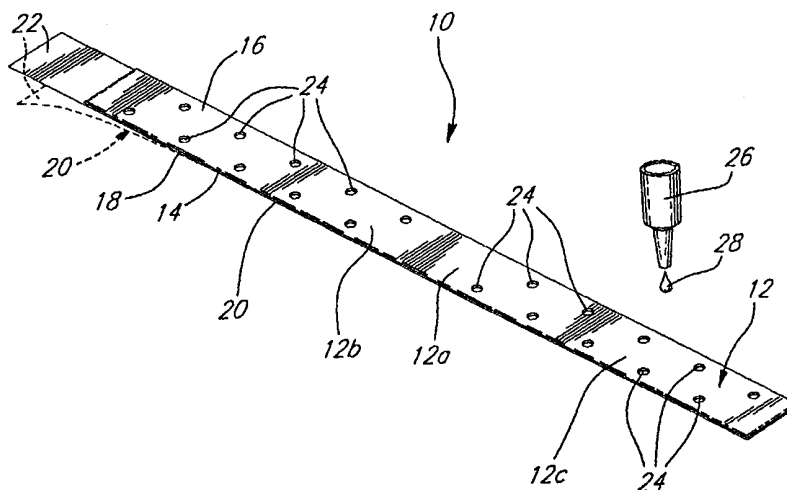

INTERNATIONAL APPLICATION PUBLISHED UNDER THE PATENT COOPERATION TREATY (PCT)

<p>(51) International Patent Classification ⁷ : A61F 13/02, A47G 1/17, A61B 17/20, A61F 13/15, 15/00, A61B 17/08</p>	A1	<p>(11) International Publication Number: WO 00/49983</p> <p>(43) International Publication Date: 31 August 2000 (31.08.00)</p>
<p>(21) International Application Number: PCT/CA00/00163</p> <p>(22) International Filing Date: 16 February 2000 (16.02.00)</p> <p>(30) Priority Data: 2,262,408 23 February 1999 (23.02.99) CA</p> <p>(71) Applicant (for all designated States except US): ADVANCED THERAPEUTIC TECHNOLOGIES AT2 INC. [CA/CA]; Suite 405, 2984 Taschereau Boulevard, Greenfield Park, Québec J4V 2G9 (CA).</p> <p>(72) Inventors; and (75) Inventors/Applicants (for US only): TETREAULT, Stephane [CA/CA]; 374 De Jumonville Str., Boucherville, Québec J4B 1K2 (CA). PHANEUF, Simon [CA/CA]; 541 Des Alouettes Str., Longueuil, Québec J4G 2N3 (CA). BENCHABANE, Mahmed [CA/CA]; 1281 Ladouceur Str., Joliette, Québec J6E 3X3 (CA).</p> <p>(74) Agents: CARRIER, Robert et al.; Swabey Ogilvy Renault, Suite 1600, 1981 McGill College Avenue, Montréal, Québec H3A 2Y3 (CA).</p>		<p>(81) Designated States: AE, AL, AM, AT, AU, AZ, BA, BB, BG, BR, BY, CH, CN, CR, CU, CZ, DE, DK, DM, EE, ES, FI, GB, GD, GE, GH, GM, HR, HU, ID, IL, IN, IS, JP, KE, KG, KP, KR, KZ, LC, LK, LR, LS, LT, LU, LV, MA, MD, MG, MK, MN, MW, MX, NO, NZ, PL, PT, RO, RU, SD, SE, SG, SI, SK, SL, TJ, TM, TR, TT, TZ, UA, UG, US, UZ, VN, YU, ZA, ZW, ARIPO patent (GH, GM, KE, LS, MW, SD, SL, SZ, TZ, UG, ZW), Eurasian patent (AM, AZ, BY, KG, KZ, MD, RU, TJ, TM), European patent (AT, BE, CH, CY, DE, DK, ES, FI, FR, GB, GR, IE, IT, LU, MC, NL, PT, SE), OAPI patent (BF, BJ, CF, CG, CI, CM, GA, GN, GW, ML, MR, NE, SN, TD, TG).</p> <p>Published With international search report.</p>

(54) Title: WOUND CLOSURE SYSTEM



(57) Abstract

A wound closure system (10) for closing a wound on a patient comprises an elongated flexible backing strip (12) having a length and width sufficient to secure facing edges of the wound in close juxtaposition to one another, the backing strip comprising a first portion disposed between the ends and adapted to overlies the facing edges of the wound, and second and third portions disposed on either side of the first portion and each provided with a predetermined number of spaced-apart apertures extending through the backing strip from one surface thereof to the other; and a first pressure-sensitive adhesive (18) coated on at least part of the first surface of the backing strip (12) including the second and third portions thereof, to adhere the backing strip to the patient with the facing edges of the wound being in close juxtaposition. The wound closure system of the invention further includes a flowable, moisturecurable surgical adhesive (28) for application into the apertures to strengthen the adhesion of the second and third portions of the backing strip to the patient.

FOR THE PURPOSES OF INFORMATION ONLY

Codes used to identify States party to the PCT on the front pages of pamphlets publishing international applications under the PCT.

AL	Albania	ES	Spain	LS	Lesotho	SI	Slovenia
AM	Armenia	FI	Finland	LT	Lithuania	SK	Slovakia
AT	Austria	FR	France	LU	Luxembourg	SN	Senegal
AU	Australia	GA	Gabon	LV	Latvia	SZ	Swaziland
AZ	Azerbaijan	GB	United Kingdom	MC	Monaco	TD	Chad
BA	Bosnia and Herzegovina	GE	Georgia	MD	Republic of Moldova	TG	Togo
BB	Barbados	GH	Ghana	MG	Madagascar	TJ	Tajikistan
BE	Belgium	GN	Guinea	MK	The former Yugoslav Republic of Macedonia	TM	Turkmenistan
BF	Burkina Faso	GR	Greece	ML	Mali	TR	Turkey
BG	Bulgaria	HU	Hungary	MN	Mongolia	TT	Trinidad and Tobago
BJ	Benin	IE	Ireland	MR	Mauritania	UA	Ukraine
BR	Brazil	IL	Israel	MW	Malawi	UG	Uganda
BY	Belarus	IS	Iceland	MX	Mexico	US	United States of America
CA	Canada	IT	Italy	NE	Niger	UZ	Uzbekistan
CF	Central African Republic	JP	Japan	NL	Netherlands	VN	Viet Nam
CG	Congo	KE	Kenya	NO	Norway	YU	Yugoslavia
CH	Switzerland	KG	Kyrgyzstan	NZ	New Zealand	ZW	Zimbabwe
CI	Côte d'Ivoire	KP	Democratic People's Republic of Korea	PL	Poland		
CM	Cameroon	KR	Republic of Korea	PT	Portugal		
CN	China	KZ	Kazakstan	RO	Romania		
CU	Cuba	LC	Saint Lucia	RU	Russian Federation		
CZ	Czech Republic	LI	Liechtenstein	SD	Sudan		
DE	Germany	LK	Sri Lanka	SE	Sweden		
DK	Denmark	LR	Liberia	SG	Singapore		
EE	Estonia						

"WOUND CLOSURE SYSTEM"

Technical Field

5 The present invention pertains to improvements in the field of wound care. More particularly, the invention relates to a wound closure system for closing a wound on a patient.

Background Art

10

When closing a wound, it is necessary to join and keep together the facing edges of the wound. If the separated skin sections are sewn, unesthetic scars may remain, and if they are stapled, such scars generally remain.

15

Cyanoacrylate-based adhesives have been suggested as an alternative to sutures. When a cyanoacrylate adhesive is employed, the separated skin sections are joined and the adhesive is applied on top of the joined sections under sterile conditions. The cyanoacrylate adhesive bonds to the skin and polymerizes so as to keep together the joined sections.

20

Although cyanoacrylate adhesives successfully bind the skin, the use of such adhesives as suture replacements can be accompanied by occasional adhesion failure resulting in wound reopening which requires closure by sutures. Fear of wound reopening is one of the reasons physicians have been reluctant to use any adhesive including cyanoacrylate based adhesives instead of sutures.

25

U.S. Patent No. 5,254,132 proposes a method of treating suturable wounds by first suturing or stapling the wound and then joining the skin between sutures or staples with a cyanoacrylate adhesive. According to this method, the wound is sutured or stapled so that the sutures or staples are separated from each other by no more than about 1.2 centimeter and no less than about 0.6 centimeter. Butyl 2-cyanoacrylate is then applied to the opposing and still separated skin sections between the sutures or staples in an amount sufficient so that upon polymerization the skin sections are joined; the application is conducted so that contact of the cyanoacrylate adhesive with the sutures or staples is avoided. The adjacent

30

35

separated skin sections are thereafter contacted under conditions that permit the adhesive to polymerize so as to join the separated skin sections. Such a method is not only time-consuming and requires particular skill to practice, but also delays healing of the wound if cyanoacrylate adhesive penetrates in
5 between the skin sections.

Surgical adhesive strips for closing wounds are also known. These strips generally do not have much tensile strength so that their use is limited to shallow wounds requiring little tension to close. Another major disadvantage resides in their permeability to water, causing the strips to
10 become unstuck upon contact with water or moisture and thereby preventing the wounded area from being washed.

U.S. Patent No. 5,259,835 discloses a wound closure device that employs a porous bonding member adapted to receive a flowable moisture-curable surgical adhesive. The bonding member is positioned by a
15 carrier member which is used to achieve initial apposition of the wound and which may later be removed. Since the adhesive flows into the bonding member and the latter serves as a matrix for the adhesive, the bonding member becomes rigid as the adhesive therein undergoes curing so that it loses flexibility. Part of the surgical adhesive also flows through the
20 bonding member and may enter into the wound.

Disclosure of the Invention

It is therefore an object of the present invention to overcome
25 the above drawbacks and to provide a wound closure system for closing wounds.

In accordance with the invention, there is provided a wound closure system for closing a wound on a patient, comprising:

30 an elongated, flexible backing strip having opposite ends, first and second surfaces facing away from one another and a length and width sufficient to secure facing edges of the wound in close juxtaposition to one another, the backing strip comprising a first portion disposed between the ends and adapted to overlie the facing edges of the wound, and second and third portions disposed on either side of the first portion and each provided

with a predetermined number of spaced-apart apertures extending through the backing strip from one surface thereof to the other;

5 a first pressure-sensitive adhesive coated on at least part of the first surface of the backing strip including the second and third portions thereof, to adhere at least the second and third portions of the backing strip to the patient with the facing edges of the wound being in close juxtaposition;

10 a first protective member removably attached to the backing strip and covering the pressure-sensitive adhesive; and

10 a flowable, moisture-curable surgical adhesive for application into the apertures to strengthen the adhesion of the second and third portions of the backing strip to the patient.

15 After removal of the protective member to expose the pressure-sensitive adhesive, application of the backing strip with the exposed pressure-sensitive adhesive onto the patient to secure the facing edges of the wound in close juxtaposition and application of the surgical adhesive into the apertures, the surgical adhesive flows through the apertures and upon curing forms discrete bonding sites cooperating with the backing strip to maintain the facing edges of the wound in close
20 juxtaposition without the cured adhesive adversely affecting the flexibility of the backing strip.

25 Applicant has found quite unexpectedly that by using a flexible backing strip having a non-perforated first portion disposed between the ends thereof and perforated second and third portions disposed on either side of the first portions, and a pressure-sensitive adhesive coated on at least part of the first surface of the backing strip including the second and third portions thereof, and applying a flowable, moisture-curable surgical adhesive into the apertures or perforations defined in the second and third portions, after application of the backing strip with the exposed
30 pressure-sensitive adhesive onto the patient to secure the facing edges of the wound in close juxtaposition, the surgical adhesive flows through the apertures and upon curing forms discrete bonding sites strengthening the adhesion of the second and third portions of the backing strip to the patient and cooperating with the backing strip to maintain the facing edges of the
35 wound in close juxtaposition without the cured adhesive adversely affecting

the flexibility of the backing strip. Since the surgical adhesive is applied on either side of the first portion of the backing strip which overlies the facing edges of the wound, the surgical adhesive does not enter into the wound so that healing of the wound is not delayed. On the other hand, since the flexibility of the backing strip is not adversely affected by the cured adhesive, the strip remains flexible and can thus follow movements of the skin.

Preferably, the backing strip comprises a sheet of polymer such as polyurethane or nylon. It can also comprise a web of fabric material such as cotton, rayon, acrylic or polyester fibers. The protective member, on the other hand, preferably comprises a film of high density polyethylene or a sheet of wax paper.

According to a preferred embodiment of the invention, the apertures are perforations having a circular cross-section with a diameter ranging from 0.5 to 3 mm, preferably from 1 to 2 mm. For a backing strip with the first or second surface thereof defining an area of about 12 cm², the number of perforations defined in each of the second and third portions can vary between 4 and 20, and preferably ranges from 8 to 12. Preferably, a second protective member having a second pressure-sensitive adhesive coated on one side thereof is removably attached to the backing strip and covers the second surface thereof, the strip being disposed between the first and second protective members. The second protective member is provided with a corresponding number of perforations registering with the perforations defined in the second and third portions of the backing strip, and being in flow communication therewith. The provision of such a second protective member prevents the surgical adhesive from contacting the second surface of the backing strip during its application so that when the second protective member together with the second pressure-sensitive adhesive are removed from the backing strip following application of the surgical adhesive, there is no surgical adhesive on the second surface, which upon curing could adversely affect the flexibility of the backing strip. The second protective member preferably comprises a film of low density polyethylene. Instead of using a second pressure-sensitive adhesive, it is also possible to removably attach the second protective member to the backing strip by heat or pressure application.

According to another preferred embodiment, the second and third portions of the backing strip each have an end edge and a pair of opposite side edges, and the apertures are U-shaped notches defined along the side and end edges of each of the second and third portions. Preferably, a removable second protective member similar to the one described above, but having perforations registering with the notches and being in flow communication therewith, covers the second surface of the backing strip.

According to a further preferred embodiment, the second and third portions of the backing strip are each provided with at least one fold line extending transversely of the strip between the apertures to increase the flexibility of the backing strip.

According to yet another preferred embodiment, the second and third portions of the backing strip are each provided with a plurality of spaced-apart anchoring elements disposed between the apertures and projecting outwardly from the first surface. These anchoring elements assist in securing the facing edges of the wound in close juxtaposition.

Brief Description of Drawings

Further features and advantages of the present invention will become more readily apparent from the following description of preferred embodiments as illustrated by way of examples in the accompanying drawings, in which:

Figure 1 is a top perspective view of a wound closure system according to a preferred embodiment of the invention;

Figure 2 is a top perspective view of a wound closure system similar to that illustrated in Fig. 1, but with the backing strip provided with a plurality of spaced-apart transversely extending fold lines;

Figure 3 is a fragmentary bottom perspective view of a wound closure system similar to that illustrated in Fig. 2, but with the backing strip provided with a plurality of spaced-apart downwardly extending anchoring elements;

Figure 4 is a top perspective view of a wound closure system similar to that illustrated in Fig. 1, but with the backing strip provided with a second protective member;

Figure 5 is a top perspective view of a wound closure system according to another preferred embodiment of the invention;

Figure 6 is a top perspective view of a wound closure system similar to that illustrated in Fig. 5, but with the backing strip provided with a plurality of spaced-apart transversely extending fold lines;

Figure 7 is a fragmentary bottom perspective view of a wound closure system similar to that illustrated in Fig. 6, but with the backing strip provided with a plurality of spaced-apart downwardly extending anchoring elements; and

Figure 8 is a top perspective view of a wound closure system similar to that illustrated in Fig. 5, but with the backing strip provided with a second protective member.

Modes for Carrying out the Invention

Referring first to Fig. 1, there is illustrated a wound closure system which is generally designated by reference numeral 10 and used for closing a wound on a patient (not shown). The wound closure system 10 comprises an elongated flexible backing strip 12 having surfaces 14 and 16 facing away from one another with the surface 14 being coated with a pressure-sensitive adhesive 18. The backing strip 12 has a length and width sufficient to secure facing edges of the wound in close juxtaposition to one another. A protective member 20 is removably attached to the backing strip 12 and covers the adhesive 18. The protective member 20 extends beyond an end edge of the backing strip 12 to define a finger-grip tab 22. The backing strip 12 has a substantially central portion 12a adapted to overlie the facing edges of the wound, and two portions 12b, 12c disposed on either side of portion 12a and each provided with a predetermined number of spaced-apart circular perforations 24 extending through the backing strip from one surface to the other.

The wound closure system 10 further includes a source 26 of flowable, moisture-curable surgical adhesive 28 for application into the perforations 24. Examples of suitable surgical adhesives which can be used include cyanoacrylates such as n-butyl 2-cyanoacrylate and octyl 2-cyanoacrylate.

In use, the protective member 20 is first peeled-off to expose the pressure-sensitive adhesive 18 and one of the portions 12b,12c of the backing strip 12 with the exposed adhesive 18 is adhered to one of the separated skin sections, which is then pulled in a direction towards the other separated skin section to bring the facing edges of the wound in close juxtaposition to one another, and the other portion of the strip 12 is adhered to the other skin section, thereby closing the wound and securing the facing edges thereof in close juxtaposition. The surgical adhesive 28 is then applied into the perforations 24 defined in the portions 12b,12c of the backing strip 12 to strengthen the adhesion of the portions 12b and 12c to the patient's skin. The adhesive 28 flows through the perforations 24 and upon curing forms discrete bonding sites cooperating with the strip 12 to maintain the facing edges of the wound in close juxtaposition without the cured adhesive adversely affecting the flexibility of the strip 12.

The wound closure system 10A illustrated in Fig. 2 is similar to the one shown in Fig. 1, with the exception that the backing strip is provided with a plurality of spaced-apart transversely extending fold lines 30 to increase the flexibility of the strip 12. As shown, the fold lines 30 extend between the perforations 24.

The wound closure system 10B which is partially illustrated in Fig. 3 is similar to the one shown in Fig. 2, with the exception that each of the portions 12b,12c of the backing strip 12 is provided with a plurality of spaced-apart hook-shaped elements 32 disposed between the perforations 24 and projecting outwardly from the surface 14. The anchoring elements 32 assist in securing the facing edges of the wound in close juxtaposition.

The wound closure system 10C illustrated in Fig. 4 is similar to the one shown in Fig. 1, with the exception that a second protective member 34 having a pressure-sensitive adhesive (not shown) coated on one side thereof is removably attached to the backing strip 12 and covers the surface 16, the strip 12 being disposed between the protective members 20 and 34. The protective member 34 is provided with perforations 36 whose number is the same as the number of perforations 24 defined in the portions 12b,12c of the strip 12. The perforations 36 register with the perforations 24 and are in flow communication therewith. The protective member 34 extends beyond an end edge of the backing strip to define a finger-grip tab

38 which is free of adhesive. The provision of such a protective member 34 prevents the surgical adhesive 28 from contacting the surface 16 of the backing strip during its application so that when the protective member 34 together with the pressure-sensitive adhesive coated thereon are removed from the backing strip 12 following application of the surgical adhesive 28, there is no surgical adhesive 28 on the surface 16, which upon curing could adversely affect the flexibility of the backing strip 12.

Turning to Fig. 5, there is illustrated another wound closure system which is generally designated by reference numeral 100 and comprises an elongated flexible backing strip 102 having surfaces 104 (shown in Fig. 7) and 106 facing away from one another with the surface 104 being coated with a pressure-sensitive adhesive 108 (shown in Fig. 7). The backing strip has a length and width sufficient to secure facing edges of a wound (not shown) in close juxtaposition to one another. A protective member 110 is removably attached to the backing strip and covers the adhesive 108. The protective member 110 extends beyond an end edge of the backing strip 102 to define a finger-grip tab 112. The backing strip has a substantially central portion 102a adapted to overlie the facing edges of the wound, and two portions 102b, 102c disposed on either side of portion 102a. A plurality of spaced-apart generally U-shaped notches 114 are defined along the side and end edges of each of the portions 102b, 102c.

The wound closure system 100 further includes a source 116 of flowable, moisture curable adhesive 118 which is the same as the adhesive 28 shown in Figs 1-4, for application into the notches 114. It is used in the same manner as the wound closure system 10 shown in Fig. 1 to close a wound.

The wound closure system 100A illustrated in Fig. 6 is similar to the one shown in Fig. 5, with the exception that the backing strip 102 is provided with a plurality of spaced-apart transversely extending fold lines 120 to increase the flexibility of the strip 102. As shown, the fold lines 120 extend between the notches 114.

The wound closure system 100B which is partially illustrated in Fig. 7 is similar to the one shown in Fig. 6, with the exception that each of the portions 102b, 102c of the backing strip 102 is provided with a plurality of spaced-apart hook-shaped anchoring elements 122 projecting

outwardly from the surface 104. The anchoring elements 122 serve the same purpose as the anchoring elements 32 shown in Fig. 3.

The wound closure system 100C illustrated in Fig. 8 is similar to the one shown in Fig. 5, with the exception that a second protective member 124 having a pressure-sensitive adhesive (not shown) coated on one side thereof is removably attached to the backing strip 102 and covers the surface 106, the strip 102 being disposed between the protective members 110 and 124. The protective member 124 is provided with square perforations 126 whose number is the same as the number of notches 114. The perforations 126 register with the notches 114 and are in flow communication therewith. The protective member 124 extends beyond one of the end edges of the backing strip 102 to define a finger-grip tab 128 which is free of adhesive. The protective member 124 also extends beyond the other end edge of the strip 102 and side edges thereof to define an end portion 130 and lateral portions 132,134. Similarly, the protective member 110 extends beyond the other end edge of the strip 102 and side edges thereof to define an end portion 136 and lateral portions 138,140. The end portions 130,136 and lateral portions 132,138 and 134,140 face one another and are releasably bonded together by the adhesive coated on the protective member 124. The member 124 serves the same purpose as the member 34 shown in Fig. 4. It also serves to confine the surgical adhesive 118 in the notches 114 during curing of the adhesive 118.

Claims

1. A wound closure system for closing a wound on a patient, comprising:
 - 5 an elongated flexible backing strip having opposite ends, first and second surfaces facing away from one another and a length and width sufficient to secure facing edges of the wound in close juxtaposition to one another, said backing strip comprising a first portion disposed between said ends and adapted to overlie the facing edges of said wound, and second and
10 third portions disposed on either side of said first portion and each provided with a predetermined number of spaced-apart apertures extending through said backing strip from said first surface to second surface;
 - a first pressure-sensitive adhesive coated on at least part of the first surface of said backing strip including said second and third portions
15 thereof, to adhere at least said second and third portions of said backing strip to the patient with the facing edges of said wound in said close juxtaposition;
 - a first protective member removably attached to said backing strip and covering said pressure-sensitive adhesive; and
 - a flowable, moisture-curable surgical adhesive for application
20 into said apertures to strengthen the adhesion of said second and third portions of said backing strip to the patient;whereby after removal of said protective member to expose said pressure-sensitive adhesive, application of said backing strip with the exposed pressure-sensitive adhesive onto said patient to secure the facing edges of said wound in
25 said close juxtaposition and application of said surgical adhesive into said apertures, said surgical adhesive flows through said apertures and upon curing forms discrete bonding sites cooperating with said backing strip to maintain the facing edges of said wound in said close juxtaposition without the cured adhesive adversely affecting the flexibility of said backing strip.
30
2. A wound closure system according to claim 1, wherein said backing strip comprises a web of fabric material.
3. A wound closure system according to claim 1, wherein said
35 backing strip comprises a sheet of polymer selected from the group consisting of polyurethane and nylon.

4. A wound closure system according to claim 1, wherein said apertures are perforations defined in said second and third portions of said backing strip.
- 5
5. A wound closure system according to claim 4, wherein said perforations have a circular cross-section with a diameter ranging from 0.5 to 3 mm.
- 10
6. A wound closure system according to claim 5, wherein said perforations have a diameter between 1 and 2 mm.
7. A wound closure system according to claim 5 or 6, wherein the number of perforations defined in each of said second and third portions ranges from 4 to 20 when the first or second surface of said backing strip has an area of about 12 cm².
- 15
8. A wound closure system according to claim 7, wherein the number of perforations is between 8 and 12.
- 20
9. A wound closure system according to any one of claims 4 to 8, wherein a second protective member having a second pressure-sensitive adhesive coated on one side thereof is removably attached to said backing strip and covers said second surface, said strip being disposed between said first and second protective members, and wherein said second protective member is provided with a corresponding number of perforations registering with the perforations defined in said second and third portions of said backing strip, and being in flow communication therewith.
- 25
- 30
10. A wound closure system according to any one of claims 4 to 8, wherein a second protective member is removably attached to said backing strip by heat or pressure application and covers said second surface, said strip being disposed between said first and second protective members, and wherein said second protective member is provided with a corresponding number of perforations registering with the perforations defined in said second and third portions said backing strips, and being in flow communication therewith.
- 35

11. A wound closure system according to claim 1, wherein said second and third portions of said backing strip each have an end edge and a pair of opposite side edges, and wherein said apertures are notches defined
5 along the side and end edges of each of said second and third portions.

12. A wound closure system according to claim 11, wherein said notches are U-shaped.

10 13. A wound closure system according to claim 11 or 12, wherein a second protective member having a second pressure-sensitive adhesive coated on one side thereof is removably attached to said backing strip and covers said second surface, said strip being disposed between said first and second protective members, and wherein said second protective member is provided
15 with a corresponding number of perforations registering with said notches and being in flow communication therewith.

14. A wound closure system according to claims 11 or 12, wherein a second protective member is removably attached to said backing strip by heat
20 or pressure application and covers said second surface, said strip being disposed between said first and second protective members, and wherein said second protective member is provided with a corresponding number of perforations registering with said notches and being in flow communication therewith

25 15. A wound closure system according to any one of claims 9, 11, 13 and 14, wherein said second protective member comprises a film of low density polyethylene.

30 16. A wound closure system according to any one of claims 1 to 15, wherein said first protective member comprises a film of high density polyethylene or a sheet of wax paper.

35 17. A wound closure system according to any one of claims 1 to 16, wherein said second and third portions of said backing strip are each provided

with at least one fold line extending transversely of said strip between said apertures to increase the flexibility of said backing strip.

18. A wound closure system according to any one of claims 1 to 14,
5 wherein said second and third portions of said backing strip are each provided with a plurality of spaced-apart anchoring elements disposed between said apertures and projecting outwardly from said first surface.

19. A wound closure system according to claim 18, wherein said
10 anchoring elements are hook-shaped.

20. A wound closure system according to any one of claims 1 to 19,
wherein said surgical adhesive comprises a cyanoacrylate.

15 21. A wound closure system according to claim 20, wherein said cyanoacrylate is n-butyl 2-cyanoacrylate or octyl 2-cyanoacrylate.

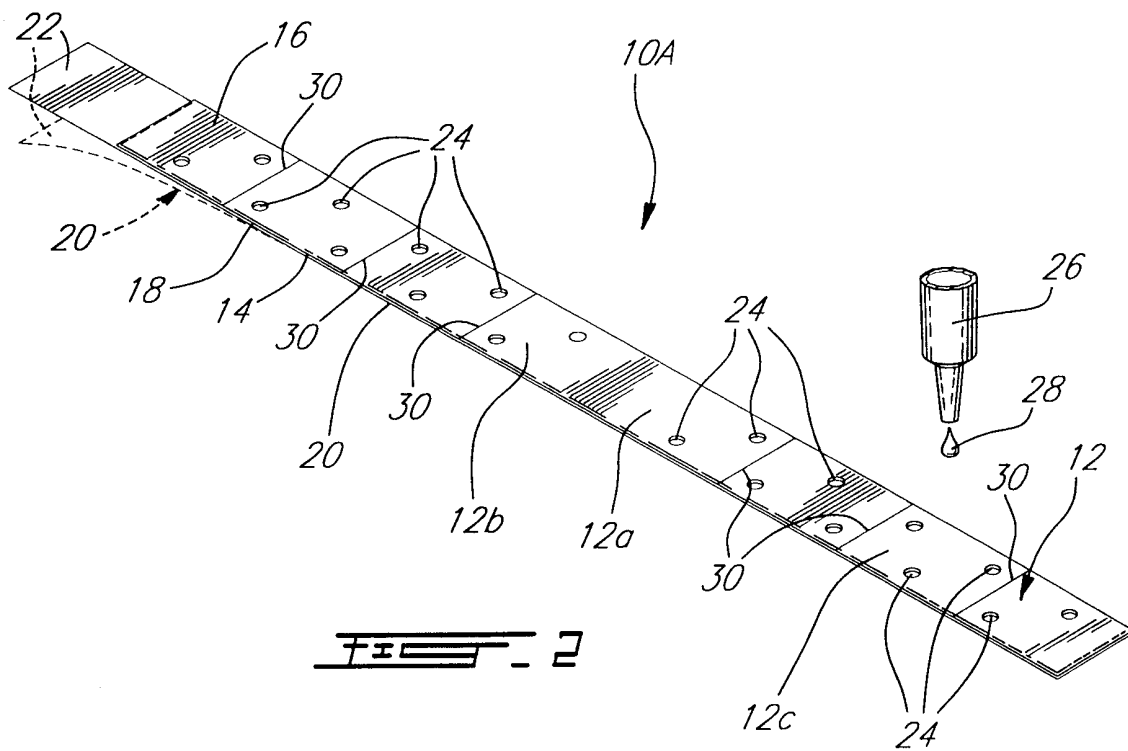
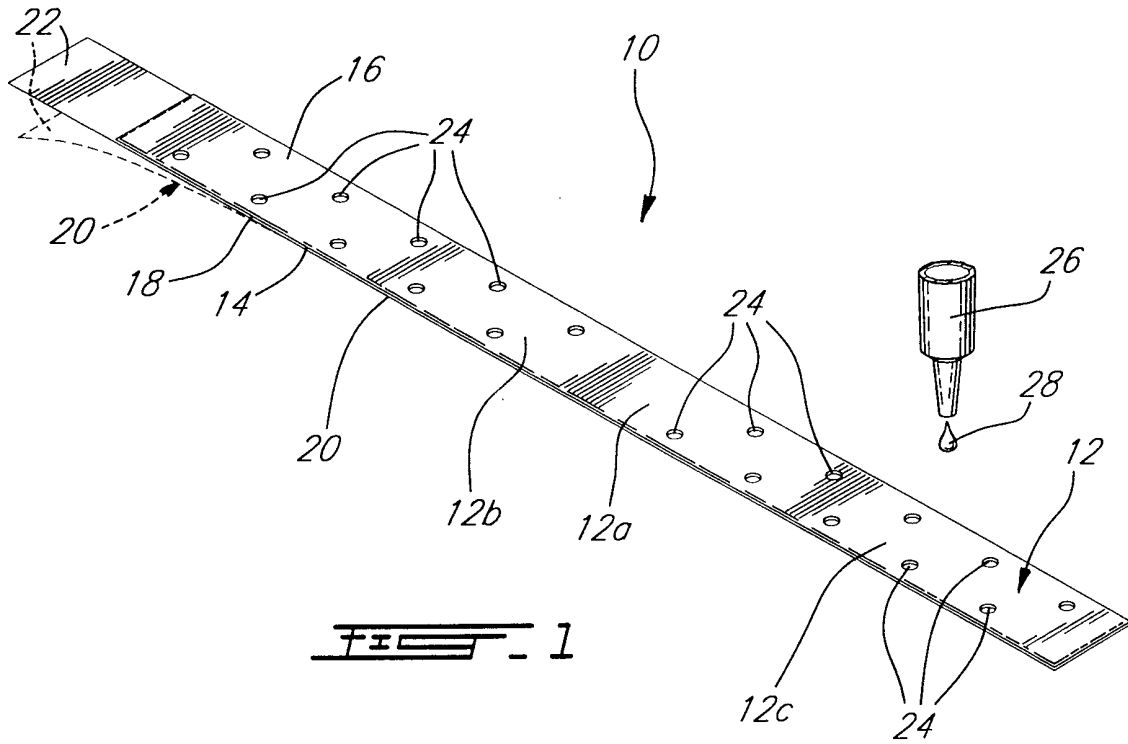

2 / 4

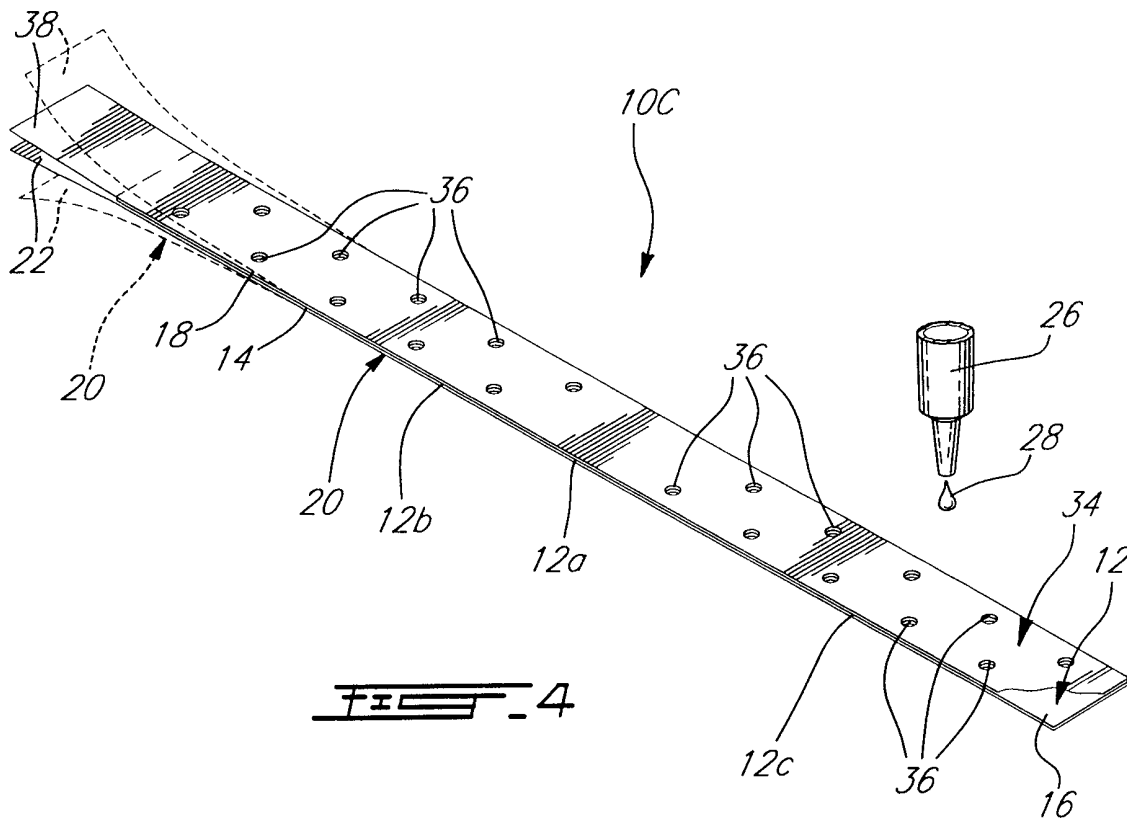
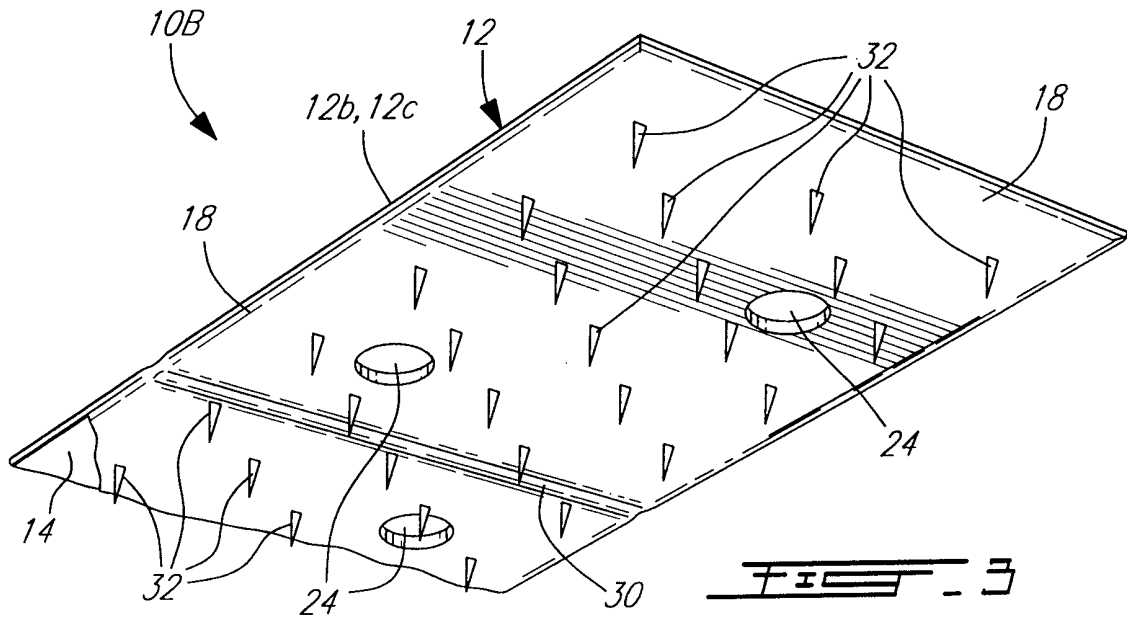

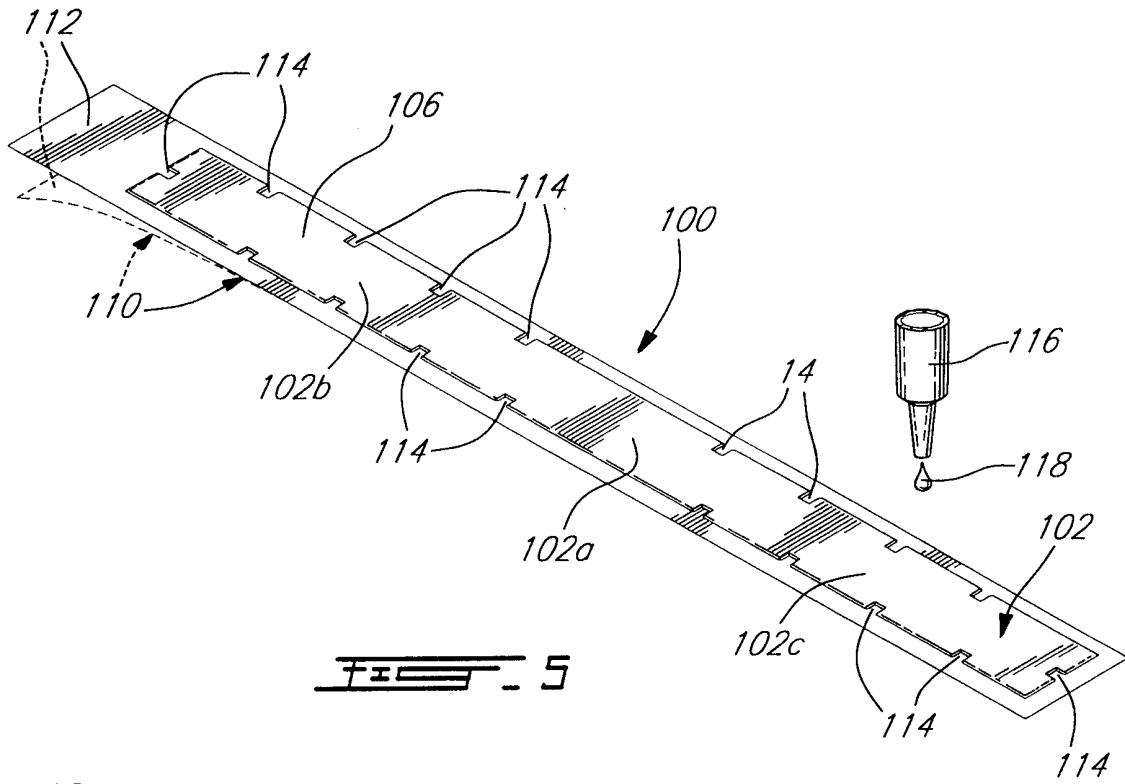

FIG. 5

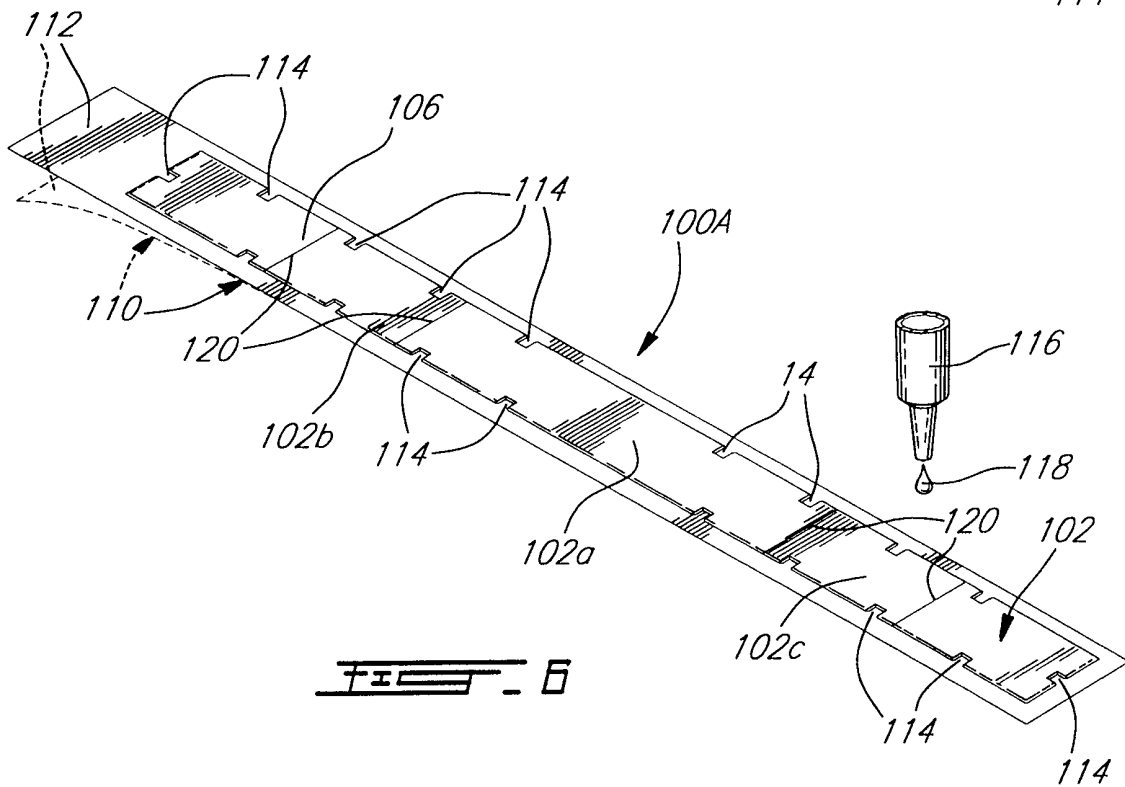
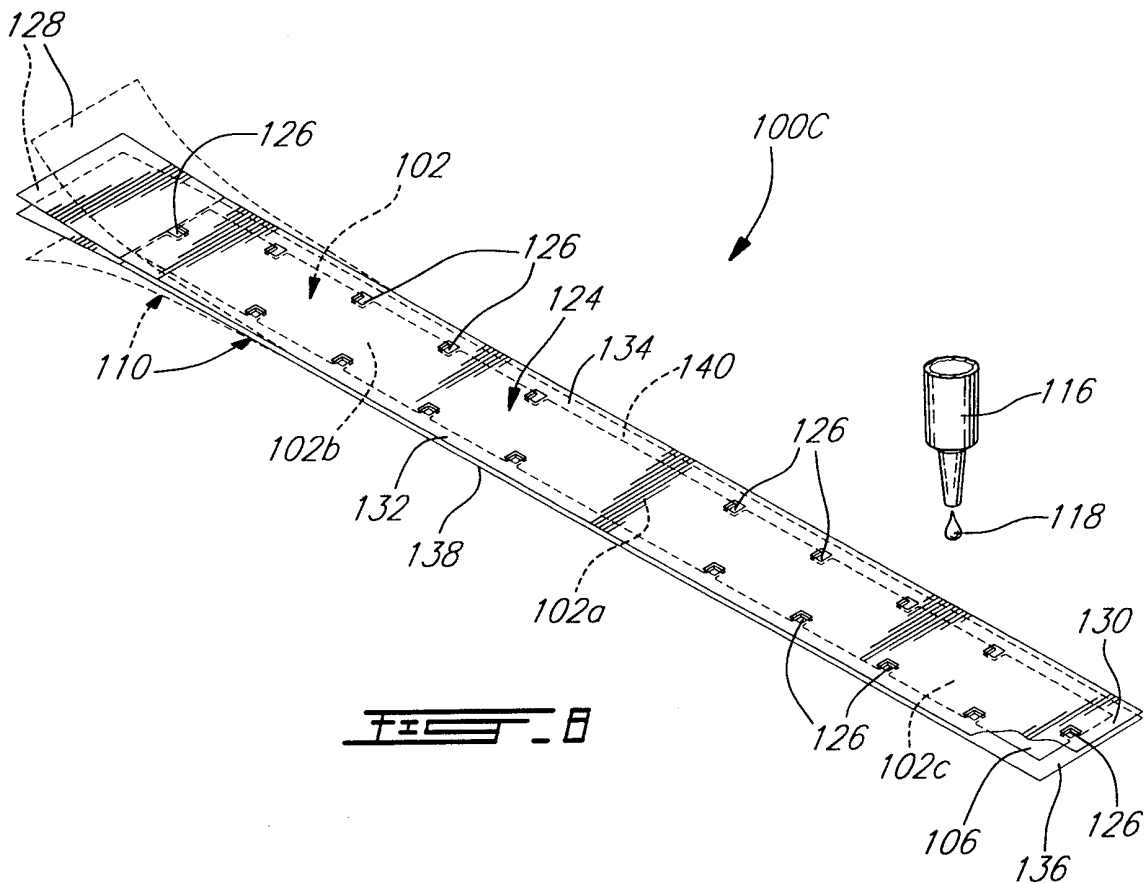
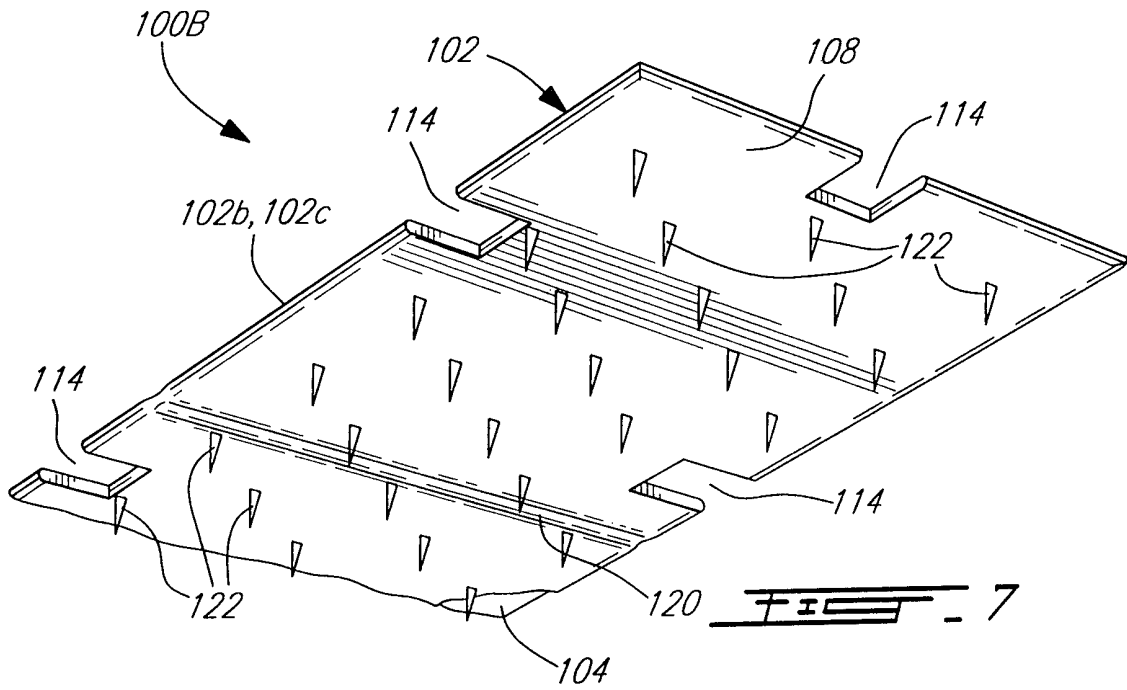

FIG. 6

4/4



INTERNATIONAL SEARCH REPORT

International Application No
PCT/CA 00/00163

A. CLASSIFICATION OF SUBJECT MATTER

IPC 7 A61F13/02 A47G1/17 A61B17/20 A61F13/15 A61F15/00
A61B17/08

According to International Patent Classification (IPC) or to both national classification and IPC

B. FIELDS SEARCHED

Minimum documentation searched (classification system followed by classification symbols)

IPC 7 A61F A47G A61B

Documentation searched other than minimum documentation to the extent that such documents are included in the fields searched

Electronic data base consulted during the international search (name of data base and, where practical, search terms used)

C. DOCUMENTS CONSIDERED TO BE RELEVANT

Category °	Citation of document, with indication, where appropriate, of the relevant passages	Relevant to claim No.
X	US 5 259 835 A (CLARK JEFFREY G ET AL) 9 November 1993 (1993-11-09)	1,4-8, 20,21 2,3,16, 17
Y	column 3, line 30 -column 5, line 31 column 9, line 55 -column 10, line 16 figures 6,26 ---	
Y	EP 0 300 815 A (ETHICON INC) 25 January 1989 (1989-01-25) page 2, line 40-46 ---	2
Y	US 4 600 001 A (GILMAN THOMAS) 15 July 1986 (1986-07-15) column 3, line 35-47 ---	3
	-/--	

Further documents are listed in the continuation of box C.

Patent family members are listed in annex.

° Special categories of cited documents :

- "A" document defining the general state of the art which is not considered to be of particular relevance
- "E" earlier document but published on or after the international filing date
- "L" document which may throw doubts on priority claim(s) or which is cited to establish the publication date of another citation or other special reason (as specified)
- "O" document referring to an oral disclosure, use, exhibition or other means
- "P" document published prior to the international filing date but later than the priority date claimed

- "T" later document published after the international filing date or priority date and not in conflict with the application but cited to understand the principle or theory underlying the invention
- "X" document of particular relevance; the claimed invention cannot be considered novel or cannot be considered to involve an inventive step when the document is taken alone
- "Y" document of particular relevance; the claimed invention cannot be considered to involve an inventive step when the document is combined with one or more other such documents, such combination being obvious to a person skilled in the art.
- "&" document member of the same patent family

Date of the actual completion of the international search

15 May 2000

Date of mailing of the international search report

30/05/2000

Name and mailing address of the ISA

European Patent Office, P.B. 5818 Patentlaan 2
NL - 2280 HV Rijswijk
Tel. (+31-70) 340-2040, Tx. 31 651 epo nl,
Fax: (+31-70) 340-3016

Authorized officer

Bichlmayer, K-P

INTERNATIONAL SEARCH REPORT

International Application No

PCT/CA 00/00163

C.(Continuation) DOCUMENTS CONSIDERED TO BE RELEVANT

Category	Citation of document, with indication, where appropriate, of the relevant passages	Relevant to claim No.
A	EP 0 641 553 A (SQUIBB & SONS INC) 8 March 1995 (1995-03-08) column 3, line 37-47 column 6, line 16-21 figure 1 ----	1
A	US 4 498 655 A (TENDLER ROBERT K) 12 February 1985 (1985-02-12) abstract; figures 12,14 ----	1
A	US 4 161 176 A (HARRIS FREDERICK E ET AL) 17 July 1979 (1979-07-17) column 2, line 1-25 figure 1 ----	9,10,13, 14
A	EP 0 870 488 A (HOLLISTER INC) 14 October 1998 (1998-10-14)	11
Y	column 5, line 27,28 figure 1 ----	16
Y	EP 0 700 674 A (PROCTER & GAMBLE) 13 March 1996 (1996-03-13) column 1, line 35-37 ----	16
Y	US 4 360 020 A (HITCHCOCK JR JAMES R ET AL) 23 November 1982 (1982-11-23) abstract; figure 5 -----	17

INTERNATIONAL SEARCH REPORT

Information on patent family members

International Application No

PCT/CA 00/00163

Patent document cited in search report	Publication date	Patent family member(s)	Publication date
US 5259835 A	09-11-1993	AU 660714 B	06-07-1995
		AU 2547992 A	05-04-1993
		CA 2116447 A	01-03-1993
		EP 0601086 A	15-06-1994
		JP 6509966 T	10-11-1994
		WO 9304650 A	18-03-1993
		US 5445597 A	29-08-1995
EP 0300815 A	25-01-1989	AT 80991 T	15-10-1992
		AU 605890 B	24-01-1991
		AU 1925388 A	27-01-1989
		BR 8803668 A	14-02-1989
		CA 1322504 A	28-09-1993
		DE 3875001 A	05-11-1992
		DE 3875001 T	15-04-1993
		IN 169554 A	09-11-1991
		JP 1043253 A	15-02-1989
		JP 2752380 B	18-05-1998
		MX 170202 B	11-08-1993
		NZ 225477 A	26-06-1990
		US 4999235 A	12-03-1991
		ZA 8805375 A	28-03-1990
US 4600001 A	15-07-1986	NONE	
EP 0641553 A	08-03-1995	US 5437623 A	01-08-1995
		AT 174500 T	15-01-1999
		AU 678257 B	22-05-1997
		AU 6885494 A	09-02-1995
		CA 2129323 A	03-02-1995
		DE 69415241 D	28-01-1999
		DE 69415241 T	09-09-1999
		JP 7163621 A	27-06-1995
		NO 942870 A	03-02-1995
		ZA 9405760 A	02-02-1996
US 4498655 A	12-02-1985	US 4309016 A	05-01-1982
US 4161176 A	17-07-1979	NONE	
EP 0870488 A	14-10-1998	US 5902260 A	11-05-1999
		CA 2228726 A	14-09-1998
		CA 2228833 A	14-09-1998
		EP 0864311 A	16-09-1998
		JP 10263006 A	06-10-1998
		JP 10263007 A	06-10-1998
		US 5891077 A	06-04-1999
EP 0700674 A	13-03-1996	NONE	
US 4360020 A	23-11-1982	AU 7176981 A	07-12-1981
		BR 8108612 A	06-04-1982
		CA 1161716 A	07-02-1984
		DE 3173175 D	23-01-1986
		EP 0051658 A	19-05-1982
		IT 1135792 B	27-08-1986
		JP 57500680 T	22-04-1982
		WO 8103283 A	26-11-1981

INTERNATIONAL SEARCH REPORT

Information on patent family members

International Application No

PCT/CA 00/00163

Patent document cited in search report	Publication date	Patent family member(s)	Publication date
US 4360020 A		US 4519795 A	28-05-1985
		AU 547736 B	31-10-1985
		BE 888786 A	28-08-1981
		ZA 8102757 A	28-04-1982
