

(No Model.)

E. G. HASTINGS.  
ROLLING WINDOW SCREEN.

No. 522,660.

Patented July 10, 1894.

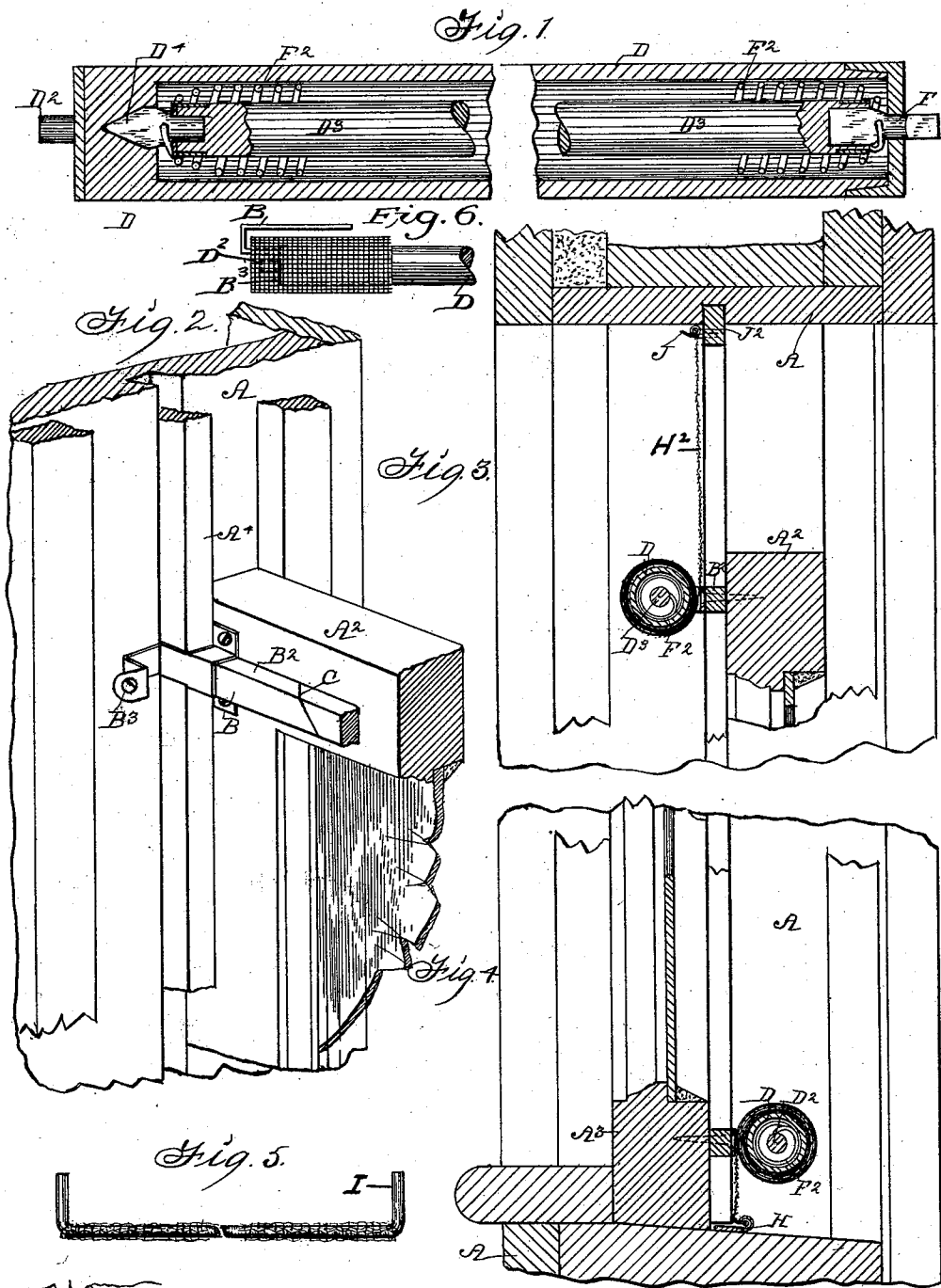

Witnesses:  
 Charles F. Wilcox.  
 C. H. Orwig.

Inventor: Edwin G. Hastings.  
 By Thomas S. Orwig, and  
 J. Ralph Orwig, Atty's.

# UNITED STATES PATENT OFFICE.

EDWIN G. HASTINGS, OF DES MOINES, IOWA.

## ROLLING WINDOW-SCREEN.

SPECIFICATION forming part of Letters Patent No. 522,660, dated July 10, 1894.

Application filed January 5, 1894. Serial No. 495,883. (No model.)

*To all whom it may concern:*

Be it known that I, EDWIN G. HASTINGS, a citizen of the United States of America, residing at Des Moines, in the county of Polk and State of Iowa, have invented an Improved Rolling Window-Screen, of which the following is a specification.

The object of my invention is to provide an improved rolling window screen adapted to be attached to the sliding sash of a window by means of brackets constructed so as to admit journals on the ends of said rollers and permit the screen or netting on said rollers to completely overlap the parting stop fixed to the window frame and to provide a strip at the top of the lower sash adapted to close the space between the sash and roller and capable of having its central portion removed to permit insects on said screen to escape outside of the window.

To this end my invention consists in details in the construction of the brackets for supporting the rollers in the device for closing the space between the rollers and the sashes and in certain other details of construction of parts as hereinafter set forth, pointed out in my claims and illustrated in the accompanying drawings, in which—

Figure 1 is a longitudinal sectional view of the roller. Fig. 2 a detail perspective view of a portion of a window frame and a top sash therein, showing the device for securing the roller to the sash. Fig. 3 is a transverse sectional view of the top portion of a window frame with the top sash therein and a roller attached thereto and the screen covering the space between the sash and frame. Fig. 4 is a like view of the bottom of a window frame and lower sash showing a roller connected with the sash and the screen attached to the frame. Fig. 5 is a top view of a modified form of device for attaching the screen to the window frame. Fig. 6 is a detail view showing the rollers in position upon the bracket and the netting wound thereupon and overlapping the bracket.

Referring to the accompanying drawings the reference letter A is used to designate a window frame of the ordinary kind and A<sup>2</sup> an upper sliding sash therein and A<sup>3</sup> a lower sliding sash, A<sup>4</sup> being a parting stop between the said sashes. Brackets B are secured to

the opposite sides of the inner face of the upper sash to support the roller as follows: B<sup>2</sup> is a supporting stop secured to the said sash and of a thickness corresponding to that of the parting stop and the bracket B overlaps this stop and is secured to the window sash extended outwardly to the window frame overlapping the parting strip, bent from thence parallel with the window frame a sufficient distance to allow the roller to clear the window sash and is then bent inwardly a short distance and again parallel with the window frame and provided with an angular opening B<sup>3</sup> adapted to admit a roller, a like bracket is on each side of the sash. It will be obvious that the journals on the ends of the rollers may be passed through the openings in said brackets and the screen netting be extended beyond the ends of the rollers so as to completely overlap the parting stops of the window frame.

The aforesaid strip B<sup>2</sup> is preferably extended completely across the window sash and the central portion made detachable by being cut in a bevel at C so that said central portion may be removed to allow flies and other insects on the window to escape to the outside atmosphere.

The roller proper designated by the letter D is composed of a hollow wooden roller having a round projection D<sup>2</sup> at one end. D<sup>3</sup> is a wooden rod within said roller. D<sup>4</sup> is a flat wedge-shaped device with a rounded inner end adapted to be placed in a bore in the end of the said rod to allow the rod to rotate relative thereto, and F is a device to be placed in the other end of the rod having a flat part adapted to enter a cut in said rod, which may be made by sawing, and the outer end of said part F is angular to enter one of the brackets B. F<sup>2</sup> is a coil spring wound upon said rod and having its ends passed through the parts D<sup>4</sup> and F. Thus a simple, cheap and easily constructed roller is provided that will automatically roll and unroll as the window-sash is moved.

H designates a sheet metal strip fastened to the end of the screen H<sup>2</sup> and having inward projections at its ends adapted to be slipped under the parting stop and thus produce a detachable connection between the screen and window frame. A modified form

of this device is found in Fig. 5 and consists of a wire I bent at its ends to pass beneath the parting stop, and adapted to have the lower end of the screen H<sup>2</sup> attached to its central portion.

The upper screen is secured to the top of the window frame by means of a straight wire J fixed in the screen and adapted to rest upon the hooks J<sup>2</sup> driven in the top parting stop, as shown in Fig. 3. Either of said methods of attaching the screen may be used interchangeably although preferably used as shown.

In practical use it will be obvious that the rollers with the screens wound thereupon may be easily and quickly inserted in the brackets secured to the window sash. The ends of the screens may be connected with the window frame in the manner shown and when the sashes are moved relative to the frame the screens will automatically cover the space between the sashes and frame and will automatically roll up when the sashes are closed and by reason of the peculiar formation of the brackets for supporting the rollers, the edges of the screen will overlap the parting stop and lie close to the sides of the window frame and thereby securely close the space between the window frame and the screen.

Having thus described my invention, what I claim as new therein, and desire to secure by Letters Patent of the United States therefor, is—

1. The combination with a window frame having a sliding sash therein and two stops or guides projecting inwardly from the frame to engage the edges of the sash, of two brackets adapted to be attached to the sliding sash, bent outwardly therefrom to overlap the sides of said stops or guides, bent from thence parallel with the window frame then inwardly a short distance and then at right angles and

provided with suitable openings in their ends, a spring actuated roller having journals on its ends adapted to enter said openings in the brackets and a roll of screen netting wound upon said roller to project beyond the ends of the roller and overlap the said stops and adapted to be attached to the window frame substantially as, and for the purposes, stated.

2. In combination with a rolling window screen, a strip secured to the top of a sliding sash, a roll of screening secured to the said sash and in close engagement with said strip, and beveled cuts in said strip, near its ends, whereby its central portion may be removed or held in position against downward or outward pressure, for the purposes stated.

3. An improved rolling window screen comprising the following elements in combination, to wit, a window frame A, sashes A<sup>2</sup>, and A<sup>3</sup> therein, the parting stop A<sup>4</sup> between them, a strip B<sup>2</sup> secured to the top sash and having the removable central portion, as set forth, brackets B secured to said strip, and having the notches B<sup>2</sup> in their ends, the hollow wooden roller D having the projection D<sup>2</sup> at one end, the wooden rod D<sup>3</sup> in said roller the devices D<sup>4</sup> and F arranged as shown, the coil spring F<sup>2</sup> wound around said rod and attached to the parts D<sup>4</sup> and F, and means for securing the end of the screen to the top of the window frame, a like roll of screening attached to the outer lower sash in a similar manner and the strip secured to the lower end of the netting and adapted to be slipped under the parting stop, all substantially as, and for the purposes, stated.

EDWIN G. HASTINGS.

Witnesses:

J. C. SWEET,

J. RALPH ORWIG.