

(19) World Intellectual Property Organization
International Bureau



(43) International Publication Date
17 August 2006 (17.08.2006)

PCT

(10) International Publication Number
WO 2006/086466 A2

- (51) International Patent Classification:
G02B 6/34 (2006.01)
- (21) International Application Number:
PCT/US2006/004419
- (22) International Filing Date: 9 February 2006 (09.02.2006)
- (25) Filing Language: English
- (26) Publication Language: English
- (30) Priority Data:
11/056,507 11 February 2005 (11.02.2005) US
- (71) Applicant (for all designated States except US):
WASATCH PHOTONICS, INC. [US/US]; 1305 North
1000 West, Suite 120, Logan, Utah 84321 (US).

- (72) Inventors; and
- (75) Inventors/Applicants (for US only): **CIFELLI, Dan**
[US/US]; 712 Bancroft Road, Suite 332, Walnut Creek,
California 94598 (US). **DICKSON, Leroy David**
[US/US]; 988 Bonanza Road, PO Box 461177, Leeds,
Utah 84746 (US). **RALLISON, Richard** [US/US]; 8501
South 400 West, PO Box 142, Paradise, Utah 84328 (US).
PEARSON, Elroy [US/US]; 1495 Maple Drive, Logan,
Utah 84321 (US).

(74) Agent: **AUSTIN, Wesley L.**; Madson & Austin, 15 West
South Temple, Suite 900, Salt Lake City, Utah 84101 (US).

(81) Designated States (unless otherwise indicated, for every
kind of national protection available): AE, AG, AL, AM,
AT, AU, AZ, BA, BB, BG, BR, BW, BY, BZ, CA, CH, CN,
CO, CR, CU, CZ, DE, DK, DM, DZ, EE, EG, ES, FI,
GB, GD, GE, GH, GM, HR, HU, ID, IL, IN, IS, JP, KE,
KG, KM, KN, KP, KR, KZ, LC, LK, LR, LS, LT, LU, LV,
LY, MA, MD, MG, MK, MN, MW, MX, MZ, NA, NG, NI,
NO, NZ, OM, PG, PH, PL, PT, RO, RU, SC, SD, SE, SG,
SK, SL, SM, SY, TJ, TM, TN, TR, TT, TZ, UA, UG, US,
UZ, VC, VN, YU, ZA, ZM, ZW.

(84) Designated States (unless otherwise indicated, for every
kind of regional protection available): ARIPO (BW, GH,
GM, KE, LS, MW, MZ, NA, SD, SL, SZ, TZ, UG, ZM,
ZW), Eurasian (AM, AZ, BY, KG, KZ, MD, RU, TJ, TM),
European (AT, BE, BG, CH, CY, CZ, DE, DK, EE, ES, FI,
FR, GB, GR, HU, IE, IS, IT, LT, LU, LV, MC, NL, PL, PT,
RO, SE, SI, SK, TR), OAPI (BF, BJ, CF, CG, CI, CM, GA,
GN, GQ, GW, ML, MR, NE, SN, TD, TG).

Published:
— without international search report and to be republished
upon receipt of that report

For two-letter codes and other abbreviations, refer to the "Guid-
ance Notes on Codes and Abbreviations" appearing at the begin-
ning of each regular issue of the PCT Gazette.

(54) Title: HIGH DISPERSION DIFFRACTION GRATING INCLUDING MULTIPLE HOLOGRAPHIC OPTICAL ELEMENTS

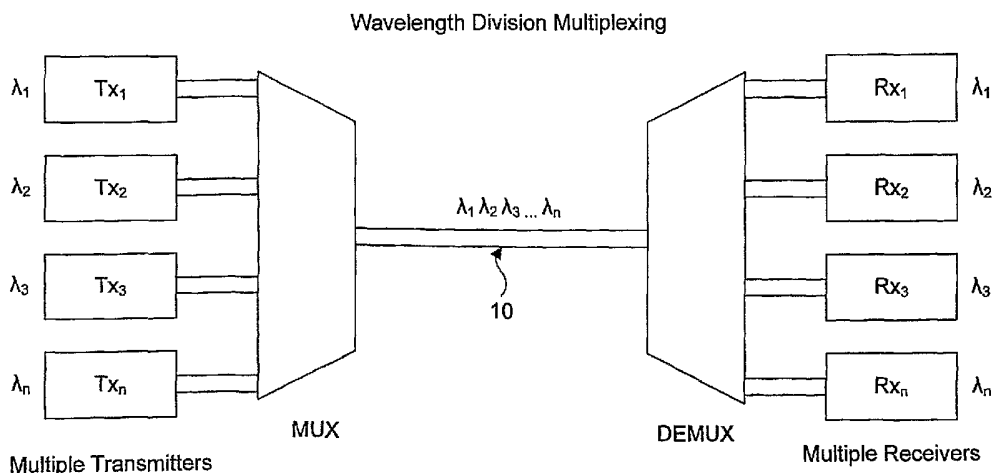

(57) Abstract: A diffraction grating having multiple holographic optical elements (HOEs), including a Dickson grating and at least one other volume phase grating (VPG). In typical embodiments, the multi-HOE grating is implemented to provide high dispersion, at least substantially uniform diffraction efficiency and at least substantially equal diffraction efficiencies for all polarizations across a wide range of wavelengths. The refractive index modulations of the Dickson grating's volume phase medium preferably have significantly greater spatial frequency than those of each other VPG of the multi-HOE grating. Typical embodiments of the multi-HOE grating can be manufactured at low cost with sufficiently small size and high dispersion (for both S-polarized and P-polarized radiation) to be useful in Dense Wavelength Division Multiplexing (DWDM) applications and other applications requiring high dispersion. The multi-HOE grating can be implemented as a transmissive or reflective grating.

WO 2006/086466 A2

HIGH DISPERSION DIFFRACTION GRATING INCLUDING MULTIPLE HOLOGRAPHIC OPTICAL ELEMENTS

5 FIELD OF THE INVENTION

The invention pertains to diffraction gratings (e.g., volume phase gratings implemented as holograms) and holographic optical elements ("HOEs"). In preferred embodiments, the invention is a diffraction grating that has high dispersion and includes multiple HOEs.

10

BACKGROUND OF THE INVENTION

The telecommunications industry is growing rapidly as a result of the expanding need for the transmitting and receiving of greater amounts of information. The industry, in order to meet the needs of the market, has developed a number of technologies that make use of the inherent broadband capabilities of fiber optics. One of these technologies is Wavelength
15 Division Multiplexing, or WDM.

WDM allows many signals to be transmitted simultaneously along a single optical fiber by sending each signal on a different carrier. Each carrier is a light beam of a slightly different wavelength than that of all of the other carriers. In order to combine these individual
20 carrier beams into a single beam at the input of the fiber, an optical multiplexer (MUX) must be employed. To separate the carriers at the receiving end of the fiber, an optical demultiplexer (DEMUX) must be employed. To be effective and economically practical, a MUX or a DEMUX must be capable of separating a multi-wavelength light beam into its individual wavelength components with a minimum amount of insertion loss and a minimum
25 amount of Polarization Dependent Loss (PDL) and be relatively inexpensive and relatively compact.

The primary function of a DEMUX is to separate the carrier beams by wavelength. There are four basic means of providing this function: (1) thin film filters, (2) arrayed waveguides, (3) fiber Bragg gratings, and (4) diffraction gratings. Thin film filters use
30 multiple filters, each tuned to a different wavelength. Separation occurs at each filter along the light propagation path. This method is effective for systems with a small number of channels (one channel corresponds to one carrier wavelength). For systems with large numbers of channels (e.g., 16 or more) thin film filters are not suitable because the insertion loss is excessive and the overall system becomes too complex.

Arrayed waveguides use an array of different length waveguides. A light beam consisting of multiple carriers, each at a different wavelength, exiting an input fiber is spread out so that it enters all of the waveguides in the array. The wavelength of each carrier in each waveguide, and the length of that waveguide, will determine its phase relative to the light of the same wavelength exiting all of the other waveguides. This phase relationship, in turn, will establish the overall phase distribution of the exiting wavefront for that particular wavelength. That phase distribution will then determine the output port to which this carrier wave will be directed.

Arrayed waveguides are very complex so that large arrays are difficult to make and some means of temperature control is generally required. This complexity places a practical upper limit on the number of channels that can be delivered with arrayed waveguides. Typically, arrayed waveguides also have high insertion loss.

Fiber Bragg gratings are similar to thin film filters except that the filtering is done by a grating created within the fiber. The wavelength selection is done at each grating within the fiber. Fiber Bragg gratings have the same insertion loss problem as thin film filters - the insertion loss becomes excessive for large numbers of channels and, as with thin film filters, the overall system becomes unacceptably complex for a large number of channels.

All three of the above technologies have a relatively high cost per channel as the number of channels increases.

The fourth technology, diffraction gratings, has the potential for both high performance (large number of channels and low insertion loss) and relatively low cost. A diffraction grating provides separation of a large number of discrete wavelengths by the process of dispersion. An incident beam consisting of multiple carriers of different wavelengths is dispersed by diffraction as the beam is either reflected from the grating or transmitted through the grating. Each wavelength of the exiting beam is reflected or transmitted at a different angle of diffraction so that each carrier can enter a different port. This would be the case for a DEMUX. For a MUX, the separate carriers would be combined into a single beam in a process that is essentially the reverse of that described above for a DEMUX.

The obvious advantage of diffraction gratings over the three other technologies is that a single, relatively simple device provides the complete wavelength separation function. Therefore, the cost, complexity and size of the MUX or DEMUX will all be less, yet the number of channels will be greater.

There are four types of diffraction gratings but only three are suitable for WDM applications: reflective and transmissive surface relief gratings, and transmissive volume phase gratings (transmissive "VPGs"). Surface relief gratings can have relatively high diffraction efficiencies, but generally only for one polarization. This creates a problem known as Polarization Dependent Loss ("PDL") in WDM where components of radiation incident on a diffraction grating have different polarizations, since these components will be diffracted by the grating with different diffraction efficiencies. While PDL cannot be eliminated in a surface relief grating, it can be minimized, although only at relatively low grating frequencies (roughly 600 lines per mm or less). This low grating frequency reduces the dispersion of the grating, making it more difficult to insert more channels and get good channel separation.

Transmissive VPGs can also have high diffraction efficiencies but, as in the case of surface relief gratings, this high diffraction efficiency generally occurs only for one polarization. Therefore, a conventional VPG typically exhibits high PDL. While PDL can be minimized in a conventional VPG, doing so either causes the overall diffraction efficiency to be low or the dispersion to be low, resulting in either unacceptably high insertion loss or relatively fewer available channels.

U.S. Patent 6,750,995, issued June 15, 2004, to LeRoy D. Dickson, discloses volume phase gratings (VPGs) configured to maximize both S-polarization diffraction efficiency and P-polarization diffraction efficiency (thereby minimizing insertion loss) and also to minimize polarization dependent loss (PDL). Herein, we will denote as a "Dickson grating" any VPG that is an "E-VPG" grating as described in US Patent 6,750,995. We will sometimes denote as a "non-Dickson grating" a VPG that is not a Dickson grating.

US Patent 6,750,995 teaches that the volume phase medium of a Dickson grating can be a hologram composed of dichromated gelatin ("DCG") having periodically modulated refractive index. However, US 6,750,995 does not teach how to implement a Dickson grating with sufficiently high dispersion (and sufficiently small size and low manufacturing cost) for some applications. A diffraction grating having desirable characteristics of a Dickson grating (minimized PDL, and high diffraction efficiency for both S-polarized and P-polarized radiation) but which can be manufactured (at an acceptably low cost and with sufficiently small size) to have higher dispersion (for both S-polarized and P-polarized components) than can be achieved in accordance with the teachings of US 6,750,995, would be useful in many WDM and other applications.

U.S. Patent 5,602,657, issued February 11, 1997, to LeRoy D. Dickson, et al. discloses a diffraction grating including multiple holographic optical elements (HOEs) held

together by a transparent adhesive (e.g., optical cement). Each HOE is a volume phase grating including a volume hologram and a substrate. The multi-HOE grating is designed to diffract a beam including components having different polarizations (e.g., P-polarized and S-polarized components) to produce a desired angular separation between the diffracted components of the diffracted beam. For example, the multi-HOE grating can include a pair of volume phase gratings whose volume holograms have relative orientation such that when the multi-HOE grating diffracts a beam, the angular separation between P-polarized and S-polarized components of the diffracted beam exceeds a predetermined minimum value. However, US 5,602,657 does not disclose how to implement a diffraction grating having high dispersion for both S-polarized and P-polarized components of incident radiation (e.g., incident radiation having a range of wavelengths), minimized PDL, and at least substantially uniformly high diffraction efficiency across a broad wavelength range of incident radiation for both S-polarized and P-polarized components of the incident radiation.

15 SUMMARY OF INVENTION

In a class of embodiments, the invention is a diffraction grating having at least two holographic optical elements (HOEs), including a Dickson grating and at least one other volume phase grating (VPG). The refractive index modulations of the Dickson grating's volume phase medium should have significantly greater spatial frequency than do those of each other VPG of the inventive grating, to ensure that the inventive grating has high dispersion for both S-polarized and P-polarized components of incident radiation (e.g., incident radiation having a range of wavelengths), minimized PDL, and preferably also, uniformly (or substantially uniformly) high diffraction efficiency across a broad wavelength range of incident radiation for both S-polarized and P-polarized components of the incident radiation. In a class of preferred embodiments, the refractive index modulations of the Dickson grating's volume phase medium have spatial frequency greater by at least a factor of two than do those of each other VPG of the inventive grating. In typical embodiments, the inventive grating not only has key desirable characteristics of a Dickson grating (minimized PDL, high S-polarization diffraction efficiency, and high P-polarization diffraction efficiency) but also provides higher dispersion (for both S-polarized and P-polarized components of incident radiation) than can be achieved by a Dickson grating or an optical device including a single diffraction grating (e.g., a Dickson grating) and one or more non-grating elements. Typically, the elements of the inventive grating are coupled to each other by suitable transparent adhesive. Typical embodiments of the inventive grating can be

manufactured at an acceptably low cost, with a sufficiently small size, and with sufficiently high dispersion (for both S-polarized and P-polarized components) to be useful in many WDM (and other) applications requiring high dispersion.

The inventive grating (sometimes referred to herein as a "multi-HOE" grating) can be implemented as either a symmetric or non-symmetric grating. The choice as to whether each constituent grating (Dickson grating or other VPG grating) of the inventive grating should be implemented as a symmetric or non-symmetric grating depends on the specific intended use or uses of the inventive grating. A non-symmetric grating has an angle of diffraction (AOD) that is unequal to the angle of incidence (AOI) at the illumination geometry that results in maximum diffraction efficiency. A symmetric grating has an AOD that is equal to the AOI at the illumination geometry that results in maximum diffraction efficiency.

In a class of embodiments, the inventive multi-HOE grating includes only one Dickson grating, and each holographic element of the multi-HOE grating other than the Dickson grating is not a Dickson grating. In other embodiments, the inventive multi-HOE grating includes two or more Dickson gratings. For example, one embodiment includes two and only two VPGs, each of which is a Dickson grating.

Although the presence of each VPG of the inventive multi-HOE grating (in addition to a first Dickson grating of the multi-HOE grating) reduces the inventive grating's S-polarization and P-polarization diffraction efficiency below the S-polarization and P-polarization diffraction efficiency of the first Dickson grating alone, the inventive grating can typically be implemented with acceptable diffraction efficiency. By ensuring that the refractive index modulations of the first Dickson grating's volume phase medium have significantly greater spatial frequency than do those of each other VPG of the inventive grating, the inventive grating's PDL will not significantly differ from the (minimized) value of the first Dickson grating's PDL. In a class of embodiments, the inventive grating provides significantly higher (e.g., higher by a factor of 1.5 to 3.15) dispersion than each individual VPG thereof can provide, with minimized PDL, high S-polarization diffraction efficiency, and high P-polarization diffraction efficiency. For example, one such embodiment includes a Dickson grating whose volume phase medium has 940 index modulations per mm (i.e., the Dickson grating has a spatial frequency of 940 "lines per mm") and a non-Dickson VPG having a spatial frequency of 260 lines per mm, is designed for diffracting radiation having wavelengths in a range centered at 1545 nm, and provides $7.43^\circ/40\text{nm}$ angular dispersion. This can be compared with the $3.00^\circ/40\text{nm}$ dispersion for a Dickson grating (designed for diffracting the same radiation) alone having spatial frequency of 940 lpmm.

The invention is useful for diffracting radiation having multiple wavelengths with adequate dispersion for many applications, including Dense Wavelength Division Multiplexing (DWDM) applications of the type common in the telecommunications industry.

In typical embodiments, the inventive grating is a transmissive grating. In alternative
5 embodiments, it is a reflective grating (for example, a reflective grating including at least one mirror or mirrored prism). For example, a reflective embodiment of the inventive grating can include constituent gratings having transmissive volume phase media and at least one
reflective element in the path of the diffracted beam, so as to be useful in a reflective, double
pass mode. In such a double pass mode, the overall dispersion can be increased over that of a
10 single-pass, transmissive version of the grating while still maintaining high overall diffraction efficiency and low PDL.

Each Dickson grating included in the inventive grating is preferably implemented to have uniformly (or substantially uniformly) high diffraction efficiency across a broad
wavelength range (including a nominal wavelength) for all polarizations and is implemented
15 (and oriented during use) with the bulk index and index modulation (and optionally also the thickness or effective thickness) of its volume phase grating material, and the angles of incidence and diffraction of the radiation to be diffracted thereby, having values such that its
diffraction efficiency for both S-polarization and P-polarization are simultaneously
maximized at the nominal wavelength. The volume phase material of each such Dickson
20 grating is created, coated, exposed and processed so as to obtain the desired values of the listed parameters. Typically, each constituent grating of the inventive multi-HOE grating is a holographic grating whose volume phase material is a hologram consisting essentially of dichromated gelatin ("DCG").

25

BRIEF DESCRIPTION OF THE DRAWINGS

Fig. 1 is a diagram of the Wavelength Division Multiplexing portion of a telecommunications system.

Fig. 2 is a cross-sectional view of an embodiment of the inventive grating.

30 Fig. 3 is a cross-sectional view of another embodiment of the inventive grating.

Fig. 4 is a cross-sectional view of another embodiment of the inventive grating.

Fig. 5 is a cross-sectional view of another embodiment of the inventive grating.

Fig. 6 is a cross-sectional view of an embodiment of a Dickson grating that is an element of some embodiments of the grating of the present invention.

Fig. 7 is a typical plot of the S and P diffraction efficiencies of a Volume Phase Grating as functions of the index modulation, Δn , for a given effective medium thickness, T , and a given pair of angles of incidence and diffraction, Θ_i , and Θ_d .

Fig. 8 is a plot of the S and P diffraction efficiencies of a Volume Phase Grating as functions of the index modulation, Δn , for a given effective medium thickness, T , and a given pair of angles of incidence and diffraction, Θ_i , and Θ_d , where these angles are greater than those in Fig. 7.

Fig. 9 is a plot of the S and P diffraction efficiencies of a Volume Phase Grating as functions of the index modulation, Δn , for a given effective medium thickness, T , and a given pair of angles of incidence and diffraction, Θ_i , and Θ_d , where these angles are less than those in Fig. 7.

Fig. 10 is a plot of the S and P diffraction efficiencies of a Volume Phase Grating as functions of the index modulation, Δn , for a Volume Phase Grating in which the angles of incidence and diffraction, Θ_i , and Θ_d , are selected so that the second peak of the S diffraction efficiency curve coincides with the first peak of the P diffraction efficiency curve.

Fig. 11 is a plot of the S and P diffraction efficiencies of a Volume Phase Grating as functions of the index modulation, Δn , for a Volume Phase Grating in which the angles of incidence and diffraction, Θ_i , and Θ_d , are selected so that the third peak of the S diffraction efficiency curve coincides with the second peak of the P diffraction efficiency curve.

Fig. 12 is a plot of the S and P diffraction efficiencies as functions of wavelength for the Volume Phase Grating of Fig. 10.

Fig. 13 is a plot of the S and P diffraction efficiencies as functions of the index modulation, Δn , for a Dickson grating.

Fig. 14 is a plot of the S and P diffraction efficiencies as functions of wavelength for a Dickson grating.

Fig. 15 is an embodiment of a Dickson grating in which a prism is used at the entrance and/or exit surface of the grating.

Fig. 15A is a cross-sectional view of an embodiment of the inventive grating, including two prisms (250 and 254), a Dickson grating (237), and another VPG (239).

Fig. 16 is an embodiment of a Dickson grating in which a reflective means is provided at the final surface of the exit prism.

Fig. 17 is an embodiment of a Dickson grating in which a reflective means is provided at the exit surface of the grating.

Fig. 18 is a plot of the S and P diffraction efficiencies as functions of wavelength for an embodiment of a Dickson grating in which the worst case PDL is reduced.

Fig. 19 is a plot of the S and P diffraction efficiencies as functions of the angle of incidence for an embodiment of a Dickson grating in which the Bragg sensitivity is reduced
5 for a double-pass design.

DETAILED DESCRIPTION

The term “transparent” is used herein with reference to an optical element (or component thereof) to denote transmissive to electromagnetic radiation that the optical
10 element is designed to transmit and/or reflect.

The expression “high dispersion” is used herein with reference to the inventive multi-HOE grating (e.g., to indicate that an embodiment of the inventive grating is configured to diffract incident radiation with “high dispersion”) to denote that the inventive grating diffracts incident radiation with greater dispersion than its constituent Dickson grating (or one
15 of its constituent Dickson gratings) would diffract the same radiation.

Fig. 1 is a block diagram of the Wavelength Division Multiplexing portion of a telecommunications system. The incoming beams from multiple sources (Tx_1, Tx_2, Tx_3, Tx_n) with corresponding multiple carrier wavelengths ($\lambda_1, \lambda_2, \lambda_3, \lambda_n$) are combined into a single beam in a multiplexer (MUX) and transmitted along a single optical fiber 10. At the receiving
20 end of the fiber the de-multiplexer (DEMUX) breaks the single beam up into many beams, each of a different wavelength ($\lambda_1, \lambda_2, \lambda_3, \lambda_n$), corresponding to the wavelength of each of the carrier beams at the input to the MUX. These beams are then directed to the corresponding receptor elements (Rx_1, Rx_2, Rx_3, Rx_n). A diffraction grating that embodies the present invention can perform the wavelength combining function of the MUX. Another diffraction
25 grating that embodies the present invention can perform the wavelength separation function of the DEMUX.

Fig. 2 is a cross-sectional view of an embodiment of the inventive grating that includes Dickson grating 104 (comprising substrate 106 and volume phase medium 108), VPG 105 (comprising substrate 111 and volume phase medium 109), and transparent, index
30 matched glue (or other transparent, index matched adhesive) 110 between medium 108 and medium 109. Each of media 108 and 109 is a hologram composed of dichromated gelatin (“DCG”) having a periodically modulated refractive index. Grating 105 is a non-symmetric grating. Dickson grating 104 is a non-symmetric grating having significantly greater (e.g., greater by at least a factor of 2, in a class of implementations) spatial frequency than does

grating 105, in the sense that volume phase medium 108 has refractive index modulations of significantly greater spatial frequency than the spatial frequency of the refractive index modulations of grating 105's volume phase medium 109. The Fig. 2 grating provides more dispersion than can be provided by grating 104 alone (or by a Dickson grating that is thicker than but otherwise identical to grating 104) without the need for a prism. The Fig. 2 grating can be manufactured with relaxed manufacturing parameters (relative to those for more complicated gratings, e.g., those including one or more prisms) due to its low Fresnel reflection losses for both S- and P-polarized radiation.

The Fig. 2 grating can be oriented so that the radiation to be dispersed thereby is incident either at either substrate 106 (in which case we refer to grating 104 as the "first" grating and grating 105 as the "last" grating) or substrate 111 (in which case we refer to grating 105 as the "first" grating and grating 104 as the "last" grating). The Bragg planes of media 108 and 109 should have relative orientation such that the exit beam angle of the first grating matches the entrance beam angle of the last grating. If it is desired that the exit beam aspect ratio is the same as that of the entrance beam, the exit beam angle of the last grating should match the entrance beam angle of the first grating.

Note that in typical embodiments of the inventive multi-HOE grating (including typical implementations of the Fig. 2 embodiment), the Bragg planes of the first VPG and last VPG should have relative orientation such that the entrance beam angle of the first VPG matches the exit beam angle of the last VPG (to ensure that the inventive multi-HOE grating does not change the beam aspect ratio), and also such that the exit beam angle of the first VPG matches the entrance beam angle of the last VPG .

In an exemplary implementation of the Fig. 2 grating, Dickson grating 104 has a spatial frequency of 940 lines per mm, grating 105 has a spatial frequency of 200 lines per mm, the s and p integers (described below) for Dickson grating 104 are selected so that internal angle of diffraction β satisfies below-discussed equation (6), and the Fig. 2 grating provides at least as much dispersion as a Dickson grating (designed for diffracting the same radiation) having a spatial frequency of 1140 lines per mm.

More generally, a typical embodiment of the inventive grating that includes a Dickson grating having spatial frequency "A" lines per mm (in the sense that the refractive index modulations of the Dickson grating's volume phase medium have spatial frequency "A" lines per mm) and one other VPG having spatial frequency "B" lines per mm, with the VPG in "contact with" (bonded "directly to") the Dickson grating in the sense that only a layer of transparent adhesive having uniform or substantially uniform thickness separates the two

gratings from each other, provides at least as much dispersion as a single VPG (designed and configured for diffracting the same radiation) having a spatial frequency equal (or substantially equal) to (A+B) lines per mm. In order for such embodiment of the inventive grating to have PDL that does not differ significantly from the (minimized) value of its constituent Dickson grating's PDL, the Dickson grating's spatial frequency "A" should be significantly greater than the other constituent grating's spatial frequency "B." In some embodiments, the spatial frequencies "A" and "B" satisfy the relation $B \leq (A/3)$. In other embodiments, the Dickson grating's spatial frequency "A" is not significantly greater than the other constituent grating's spatial frequency "B" (for example, $A = 902$ and $B = 448$ in one embodiment, and $A = B = 780.5$ in another embodiment).

In a variation on the Fig. 2 embodiment, the inventive grating can be implemented as a reflective grating if the optional mirror 112 (shown in phantom view in Fig. 2) is affixed to element 111 as shown, to make the grating useful in a reflective, double pass mode in which radiation propagates through elements 104 and 105, then reflects from mirror 112, and then propagates back through elements 105 and 104.

Fig. 3 is a cross-sectional view of another embodiment of the inventive grating that includes Dickson grating 124 (comprising substrate 126, volume phase medium 128, and flat cap 127), VPG 125 (comprising substrate 131, volume phase medium 129, and flat cap 130), and transparent, index matched glue (or other transparent, index matched adhesive) 128 between caps 127 and 130. Each of media 128 and 129 is a hologram composed of dichromated gelatin ("DCG") having a periodically modulated refractive index. Grating 125 is a non-symmetric, low spatial frequency grating. Dickson grating 124 is a non-symmetric grating having high spatial frequency, in the sense that volume phase medium 128 has refractive index modulations of greater spatial frequency than the spatial frequency of the refractive index modulations of grating 125's volume phase medium 129. Caps 127 and 130 are flat, transparent elements, which consist of fused silica in typical implementations.

The Fig. 3 grating can be oriented so that the radiation to be dispersed thereby is incident at either substrate 126 (in which case we refer to grating 124 as the "first" grating and grating 125 as the "last" grating) or substrate 131 (in which case we refer to grating 125 as the "first" grating and grating 124 as the "last" grating). The Bragg planes of media 128 and 129 should have relative orientation such that the exit beam angle of the first grating matches the entrance beam angle of the last grating. If it is desired that the exit beam aspect ratio is the same as that of the entrance beam, the exit beam angle of the last grating should match the entrance beam angle of the first grating.

Fig. 4 is a cross-sectional view of another embodiment of the inventive grating that includes Dickson grating 134 (comprising substrate 136, volume phase medium 138, and capping prism 137), VPG 135 (comprising substrate 141, volume phase medium 139, and capping prism 140), and transparent, index matched glue (or other transparent, index matched adhesive) 142 between prisms 137 and 140. Each of media 138 and 139 is a hologram composed of dichromated gelatin ("DCG") having a periodically modulated refractive index. Grating 135 is a non-symmetric, low spatial frequency grating. Dickson grating 134 is a non-symmetric grating having high spatial frequency, in the sense that volume phase medium 138 has refractive index modulations of greater spatial frequency than the spatial frequency of the refractive index modulations of grating 135's volume phase medium 139. Capping prisms 137 and 140 are transparent, and consist of fused silica in typical implementations.

The Fig. 4 grating can be oriented so that the radiation to be dispersed thereby is incident at either substrate 136 (in which case we refer to grating 134 as the "first" grating and grating 135 as the "last" grating) or substrate 141 (in which case we refer to grating 135 as the "first" grating and grating 134 as the "last" grating). The Bragg planes of media 138 and 139 should have relative orientation such that the exit beam angle of the first grating matches the entrance beam angle of the last grating. If it is desired that the exit beam aspect ratio is the same as that of the entrance beam, the exit beam angle of the last grating should match the entrance beam angle of the first grating.

Fig. 5 is a cross-sectional view of another embodiment of the inventive grating that includes VPG 150 (comprising substrate 152 and volume phase medium 154), Dickson grating 160 (comprising substrate 162 and volume phase medium 164), VPG 170 (comprising substrate 174 and volume phase medium 172), transparent, index matched glue (or other transparent, index matched adhesive) 151 between medium 154 and medium 164, and transparent, index matched glue (or other transparent, index matched adhesive) 161 between substrate 162 and medium 172. Each of media 154, 164, and 172 is a hologram composed of dichromated gelatin ("DCG") having a periodically modulated refractive index. Grating 105 is a non-symmetric, low spatial frequency grating. Dickson grating 104 is a non-symmetric grating having high spatial frequency, in the sense that volume phase medium 108 has refractive index modulations of greater spatial frequency than the spatial frequency of the refractive index modulations of grating 105's volume phase medium 109.

The Fig. 5 grating can be oriented so that the radiation to be dispersed thereby is incident either at substrate 152 (in which case we refer to grating 150 as the "first" grating and grating 170 as the "last" grating) or substrate 174 (in which case we refer to grating 170

as the “first” grating and grating 150 as the “last” grating). The Bragg planes of media 154, 164, and 172 should have relative orientation such that the exit beam angle of the first grating matches the entrance beam angle of grating 160 and the exit beam angle of grating 160 matches the entrance beam angle of the last grating. If it is desired that the exit beam aspect ratio is the same as that of the entrance beam, the exit beam angle of the last grating should match the entrance beam angle of the first grating.

Fig. 15A is a cross-sectional view of an embodiment of the inventive grating including prisms 250 and 254, Dickson grating 237, VPG 239, transparent, index matched glue 230 between prism 250 and grating 237, transparent, index matched glue 231 between gratings 237 and 239, and transparent, index matched glue 232 between grating 239 and prism 254. Each of gratings 237 and 239 is a hologram composed of dichromated gelatin (“DCG”) having a periodically modulated refractive index. Grating 239 is a non-symmetric grating. Dickson grating 237 is a non-symmetric grating having significantly greater spatial frequency than does grating 239, in the sense that its refractive index modulations have greater spatial frequency than the spatial frequency of the refractive index modulations of grating 239. Prisms 250 and 254 are transparent, and consist of fused silica in typical implementations. In some but not all implementations, prisms 250 and 254 of Fig. 15A are mirror images of each other (with identical prism angles and refractive indices).

In one implementation, Dickson grating 237 of Fig. 15A has a spatial frequency of 902 lines per mm and grating 239 has a spatial frequency of 448 lines per mm. This implementation provides at least as much dispersion as (and has insertion loss and PDL less than) a single Dickson grating having a spatial frequency of 1350 lines per mm and which is designed for diffracting the same radiation and so that its internal angle of diffraction β satisfies equation (7). The theoretical worst case PDL of such combination of a 902 lpmm Dickson grating and a 448 lpmm is 0.06 dB, whereas the theoretical worst case PDL of a 940 line per mm Dickson grating is about 0.05 dB and the theoretical worst case PDL of a 1350 line per mm Dickson grating is about 0.22 dB. The spatial frequency values of 902 lpmm and 448 lpmm for gratings 237 and 239 in this implementation are determined by the overall device geometry, which is such that the angle of diffraction (for radiation diffracted by grating 237) is less than the angle at which the radiation is incident at grating 237.

In another implementation, Dickson grating 237 of Fig. 15A has a spatial frequency of 780.5 lines per mm and grating 239 is also a Dickson grating having spatial frequency of 780.5 lines per mm. In this implementation, the volume phase medium of each of gratings 237 and 239 has a post-process, bulk refractive index at least substantially equal to 1.32 (or

greater) and a Bragg plane tilt relative to the surface normal of about 35 degrees, and each of prisms 250 and 254 is composed of fused silica. The PDL of this implementation is about the same as that of a double-pass symmetric Dickson grating with the external mirror normal to the exiting beam. This implementation provides at least as much dispersion as a single
 5 volume phase grating having a spatial frequency of 1561 lines per mm.

In a variation on the implementation described in the previous paragraph, grating 237 and glue 231 are omitted, and a mirror is glued to the lower right surface of prism 254. In this variation (in which Dickson grating 239 preferably has a spatial frequency of 780.5 lines per mm), the overall device is useful in a reflective, double pass mode in which radiation
 10 propagates through elements 250, 239, and 254, then reflects from the mirror, and then propagates back through elements 254, 239, and 250 (exiting the device from prism 250).

Various implementations of Fig. 15A (and other embodiments of the inventive grating that include a Dickson grating and one other volume phase grating bonded directly thereto) are designed to provide the same dispersion that can be provided by a single VPG (designed and used for diffracting the same radiation) having a spatial frequency of (A+B) lines per
 15 mm. Each such embodiment of the inventive multi-HOE device includes a Dickson grating having spatial frequency "A" lines per mm and another volume phase grating having spatial frequency "B" lines per mm. The ratio A/B decreases as the value of (A+B) increases (e.g., the ratio A/B decreases to one as the value of (A+B) increases to 1561).

In these implementations, the two gratings are in contact with (bonded directly to) each other in the sense that only a layer of transparent adhesive having uniform or substantially uniform thickness separates the two gratings from each other, with θ_1 = the entrance beam angle to the first one of the two gratings (the "first grating"), θ_2 = the exit beam angle from the first grating, θ_3 = the entrance beam angle to the last one of the two
 20 gratings (the "last grating"), and θ_4 = the exit beam angle from the last grating, with:
 25

$$\theta_3 = -\theta_2 \quad (\text{E1}).$$

It follows from the grating equation (a well-known equation) for the first grating that:

$$\lambda f_1 = \sin \theta_1 + \sin \theta_2 \quad (\text{E2}), \text{ where } f_1 \text{ is the spatial frequency of the first}$$

30 grating.

It follows from the grating equation (also a well-known equation) for the last grating that:

$$\begin{aligned}
 \lambda f_2 &= \sin \theta_3 + \sin \theta_4 \\
 &= -\sin \theta_2 + \sin \theta_4 \quad \text{from eq. (E1)} \\
 &= \sin \theta_1 - \lambda f_1 + \sin \theta_4 \quad \text{from eq. (E2)} \quad \text{(E3),}
 \end{aligned}$$

where f_2 is the spatial frequency of the last grating.

5 Thus:

$$\lambda(f_1 + f_2) = \sin \theta_1 + \sin \theta_4 \quad \text{(E5)}$$

and

10

$$\lambda(f_{eq}) = \sin \theta_1 + \sin \theta_4 \quad \text{(E6)}$$

where

$$15 \quad f_{eq} = f_1 + f_2.$$

If the exit beam aspect ratio is to be the same as the entrance beam aspect ratio then $\theta_1 = \theta_4$ and:

$$20 \quad \lambda(f_{eq}) = 2 \sin \theta_1 = 2 \sin \theta_4 \quad \text{(E7).}$$

The typical design process for implementations of Fig. 15A in the general category being described with reference to immediately preceding equations (E1)-(E7), assuming that the first grating of each such implementation is a Dickson grating, is as follows:

- 25
1. Determine the spatial frequency desired for the final dual-grating package. That is f_{eq} .
 2. Calculate θ_1 using Equation (E7). This assumes that we do not want to change the aspect ratio. If we want to change the aspect ratio we will have to calculate the desired ratio of the angles, from which we can determine θ_1 and θ_4 .

3. Determine (from well-known properties of Dickson gratings coupled with prisms, including Fresnel reflection losses) the spatial frequency of the Dickson grating and the exit angle, θ_2 .
4. Determine that the entrance angle for the last grating is $-\theta_2$, from equation (E1),
5 determine the exit angle θ_4 .
5. Apply the grating equation to the last grating, using the two angles $-\theta_2$ and θ_4 as the entrance and exit angles, to calculate the spatial frequency, f_2 for the last grating.
6. Check to see that $f_1 + f_2 = f_{eq}$

The Fig. 15A grating can be oriented so that the radiation to be dispersed thereby is
10 incident either at prism 250 (in which case we refer to grating 237 as the “first” grating and grating 239 as the “last” grating) or prism 254 (in which case we refer to grating 239 as the “first” grating and grating 237 as the “last” grating). The Bragg planes of gratings 237 and 239 should have relative orientation such that the exit beam angle of the first grating matches the entrance beam angle of the last grating. If it is desired that the exit beam aspect ratio is the
15 same as that of the entrance beam, the exit beam angle of the last grating should match the entrance beam angle of the first grating.

In various embodiments of the inventive multi-HOE grating, the constituent Dickson and non-Dickson gratings can be symmetric or non-symmetric gratings. However, in
embodiments of the inventive grating that include a Dickson grating bonded directly to a non-
20 Dickson grating, these two constituent gratings must be non-symmetric gratings. Either a Dickson or non-Dickson grating of the inventive multi-HOE grating can be the first constituent grating of the inventive grating to receive the radiation to be dispersed by the inventive grating. In typical embodiments of the inventive multi-HOE grating, each non-Dickson grating has lower spatial frequency than does each Dickson grating, but this is not
25 the case in all embodiments of the invention.

Various embodiments of the inventive multi-HOE grating have one or more of the following features:

the inventive grating includes two non-Dickson gratings having relatively low spatial frequency and a non-symmetric Dickson grating having greater spatial frequency, in an
30 arrangement in which one non-Dickson grating asserts diffracted radiation to the Dickson grating and the Dickson grating asserts further-diffracted radiation to the other non-Dickson grating;

the inventive grating includes at least one prism (or other wedge part) in place of or in addition to a non-Dickson grating of another embodiment of the inventive grating (e.g. to enhance manufacturability);

5 in the inventive grating, the characteristics of one or both of a non-Dickson grating and a non-symmetric Dickson grating are adjustable to accommodate a wide range of very high dispersive configurations;

10 the inventive grating includes one or more reflective elements (e.g., the inventive grating has a reflection geometry and includes at least one mirror or mirrored prism). For example, the Fig. 4 embodiment of the inventive grating can be implemented as a reflective grating if the optional mirror 143 (shown in phantom view in Fig. 4) is affixed to element 141 as shown, to make the grating useful in a reflective, double pass mode in which radiation propagates through elements 134, 142, and 135, then reflects from mirror 143, and then propagates back through elements 135, 142, and 134. For another example, the Fig. 15A embodiment of the inventive grating can be implemented as a reflective grating if a mirror is affixed to the appropriate outer surface of prism 254 to make the Fig. 15A grating useful in a reflective, double pass mode;

15 the inventive grating includes any of a variety of combinations of HOEs, selected to alter the diffracted beam shape and/or its exit direction. For example, the inventive grating can be implemented to receive an elliptical input beam and reshape it to a circular output beam; and

20 the inventive grating has an in-line geometry (e.g., of the type used in spectrometers) known as prism/grating/prism (PGP), to reduce undesirable "smile" and "keystoning" effects.

It is contemplated that some implementations of the inventive grating may include at least one Dickson grating (and/or at least one non-Dickson grating) whose volume phase medium has index modulation greater than that typical in the art (e.g., increased index modulation produced by a process in which the starting bulk index of the volume phase medium is increased above the value typical in the art). It is also contemplated that some implementations of the inventive grating may include optimized antireflection (AR) coatings for various parameters that may relax manufacturing tolerances.

30 The inventive multi-HOE grating can be implemented to have all (or any desired subset) of the following features:

very high dispersion (to allow devices and systems including it to be more compact and allow for easier individual wavelength handling);

very high S & P polarization diffraction efficiencies (to make the most effective use of the available radiation and minimize the need for additional devices);

very low polarization dependent losses (i.e., polarization insensitivity) so that the polarization state of the incoming radiation does not matter (this is especially important in the many systems in which the polarization state(s) of the incoming radiation is (are) not known a priori, cannot be controlled, and/or is (are) variable);

wide/flat bandwidth of operation to accommodate any single set of application parameters;

wide design bandwidth to accommodate varied sets of application parameters;

athermal performance (no, or insignificant, variability with temperature and humidity);

rugged construction (product can be handled easily, and cannot easily be scratched or contaminated);

minimal stray light (does not add any noise effects);

preserves incoming/outgoing beam shape (aspect ratio) characteristics if required (e.g., does not alter a circular beam into an elliptical beam thereby possibly increasing the difficulty of efficiently aiming/coupling the diffraction beam into optical fibers);

eliminates or reduces prism use to decrease size requirements and manufacturing costs;

minimizes surfaces for ease of manufacturing, reducing Fresnel reflections, and reducing higher diffraction orders;

reduces any etalon/resonating effects arising from parallel surfaced parts;

small component size (i.e., does not increase the size of the device in which it is installed);

easily integratable (can be designed and manufactured into many electro-optic systems);

affordable (manufacturable with low cost);

reduces device/system costs (component reduces other costs associated with the device/system or its maintenance);

multiple functionality (capable of more easily providing two or more optical functions in one grating device); and

enables new applications not otherwise possible due to some or all of the above.

Fig. 6 is a cross-sectional view of a transmissive Dickson grating (identified by reference number 20) that can be used in a class of embodiments of the invention (e.g., as

grating 125 of Fig. 3). Incident beam 22, with a free space wavelength λ is incident on first surface 24 of grating 20's cover glass 26 at an angle of incidence (relative to the normal to surface 24) of θ_i degrees. Upon entering cover glass 26, the beam is refracted in accordance with the well-known Snell's law of refraction. The refracted beam 28 propagates to the interface surface 30 between cover glass 26 and volume phase medium 32, where it is again refracted in accordance with Snell's law. This further refracted beam (beam 34) propagates in volume phase medium 32 at an angle of refraction α relative to the normal to the interface surface 30.

Within volume phase medium 32 there is a periodic modulation of refractive index Δn . The surfaces of maximum refractive index are called the Bragg surfaces 46. The period of this modulation, measured along the interface surface 30, is designated as d . A portion of beam 34 that is diffracted within volume phase medium 32 is identified as diffracted beam 36. Beam 34 is diffracted within phase medium 32 in accordance with the grating equation:

$$\lambda/nd = \sin\alpha + \sin\beta$$

where λ is the free space wavelength of the incident beam, d is the grating spacing measured along the interface surface 30, n is the average bulk refractive index of the volume phase medium 32, α is the angle of the incident beam 34 within the volume phase medium 32 relative to the normal to the interface surface 30 and β is the angle of the diffracted beam 36 within the volume phase medium 32 relative to the normal to the second interface surface 40. The effective thickness of volume phase medium 32 is T .

The diffracted beam 36 will be refracted at the interface surface 40 between the volume phase medium 32 and the substrate medium 42 in accordance with Snell's law and transmitted to the exit surface 44 of the substrate 42, where it will be once again refracted in accordance with Snell's law and will exit the substrate 42 at an angle θ_d relative to the normal to the exit surface 44.

In the special, but most common, case where the four surfaces 24, 30, 40 and 44 are plane surfaces parallel to each other and the refractive indexes of the external entrance medium and the external exit medium are the same, then the grating equation can be written as:

$$\lambda/n_0d = \sin\theta_i + \sin\theta_d$$

where n_0 is the refractive index of the entrance/exit medium.

The angle between the internal incident beam 34 and the Bragg surfaces 46 within volume phase medium 32 is designated as θ . When the angle between the internal diffracted beam 36 and the Bragg surfaces 46 within the volume phase medium 32 is also θ , then the
5 Bragg condition is said to be satisfied. In the example shown in Fig. 6, the internal angle of incidence, α , is not equal to the internal angle of diffraction, β . Therefore the Bragg surfaces will be tilted (not normal to surfaces 30 and 40) as indicated in Fig. 6.

In embodiments of the present invention that are useful for WDM applications in which the inventive grating receives (and disperses) radiation having a broad range of
10 wavelengths, the incident beam wavelength, λ , that is assumed in designing the inventive grating is the nominal, or center, wavelength of one of the telecommunications bands. One such communication band is the C band, whose center wavelength is approximately 1546 nm and whose bandwidth is approximately 37 nm. The external angle of diffraction for the center wavelength is θ_d . The angle of diffraction for other wavelengths of the particular
15 telecommunications band will be greater than or less than θ_d , in accordance with the grating equation.

Dickson grating 20 can be implemented as a holographic grating whose volume phase medium 32 is dichromated gelatin (DCG) or other VPG material. Any of several volume phase materials can be used but DCG is well suited for the construction of a Dickson grating
20 because it is capable, when properly exposed and processed, of providing very high modulation of the index of refraction, a key requirement for a good Dickson grating.

Still with reference to Fig. 6, substrate material 42 on which volume phase medium 32 is coated can be glass, fused silica, or one of any number of other well known transparent materials. The choice of the substrate material will generally be determined by the thermal
25 expansion requirements. Volume phase medium 32 is typically sandwiched between two pieces of the transparent material (e.g., substrate 42 of Fig. 6, and cover, or capping, medium 26 of Fig. 6) and secured with a transparent optical adhesive, which also acts as a sealant to protect the DCG comprising medium 32 from the environment. Cover medium 26 can be
30 glass, fused silica, or one of any number of other well known transparent materials. Either or both of elements 26 and 42 are omitted in variations on the Fig. 6 design.

The theory of volume phase gratings is well known. Several theories exist but the one most applicable for thick gratings with moderate index modulation and relatively large angles of incidence and diffraction is the Kogelnik Coupled Wave Theory. While more sophisticated and precise theories exist, they are more complex and add little of significant value to the

results obtained from the Kogelnik theory when the conditions are such that only the first order diffracted beam exists and the effective thickness of the medium is relatively large. These are the conditions that pertain to Dickson gratings.

The major VPG parameters in the Kogelnik theory are the average bulk refractive index, n , of the medium, the effective thickness, T , of the medium and the index modulation, Δn of the medium. The entering and exiting beam parameters of interest are the angle of incidence, θ_i , the angle of diffraction, θ_d , and the polarization of the incoming beam. By convention, the polarization direction is defined as the direction of the electric field in the beam.

The polarization direction of an optical beam incident on an optical surface is generally defined relative to the plane of incidence, which is defined as the plane containing the chief ray of the incident beam and the normal to the surface at the point of incidence. If the polarization direction is perpendicular to the plane of incidence, the beam is said to be S-polarized, from the German word for perpendicular - Senkrecht. If the polarization direction lies in the plane of incidence, the beam is said to be P-polarized (P = parallel). If the beam is polarized in any other direction, its polarization can always be resolved into components in these two orthogonal directions. Therefore, knowing the effects on the beam of the VPG for both the S-polarization direction and the P-polarization direction will be sufficient to provide the effects for any random polarization direction.

The major parameters of interest in the Kogelnik theory are the S and P diffraction efficiencies, E_s and E_p , where diffraction efficiency is defined as the ratio of the energy, or power, in the diffracted beam to that in the incident beam, ignoring the Fresnel reflection losses.

The Kogelnik theory provides the S and P diffraction efficiencies of a VPG as functions of the product of the index modulation, Δn , and the effective thickness, T , of the medium. Generally, either effective thickness is assumed to be constant and Δn is varied or Δn is assumed to be constant and effective thickness is varied. In practice, the first approach is the most common - the effective thickness is assumed to be constant.

The effective thickness, T , is used instead of the physical thickness, T_p , because the index modulation, in general, is not constant throughout the depth of the medium. The exposing and chemical processing of many VPG materials, such as DCG, results in a decrease of Δn with depth in the medium. It is well known in the art that this variation can be taken into account by using an effective thickness that is less than the physical thickness and then using the assumption that the Δn is constant over this reduced effective thickness.

Fig. 7 is a typical plot of the S and P diffraction efficiencies of a VPG as functions of the index modulation, Δn , for a given effective thickness, T, and a given pair of angles of incidence and diffraction. Note that the P efficiency lags the S efficiency as a function of the index modulation. This is a result of the cosine factor that exists for the P polarized diffraction efficiency in the Kogelnik theory as shown in the following discussion.

In the Kogelnik theory, a parameter ν is introduced, where ν is defined by the following equation:

$$(1) \nu = \pi \Delta n T / [\lambda \sqrt{C_R C_S}]$$

where:

λ is the nominal wavelength of the incident light beam in air,

T is the effective thickness of the VPG medium,

Δn is the peak modulation of the VPG medium,

C_R is the incident beam obliquity factor (from the Kogelnik theory),

C_S is the diffracted beam obliquity factor (from the Kogelnik theory), and

C_R and C_S are both functions of the average bulk refractive index, n, of the VPG medium.

The S-polarization diffraction efficiency is then given by the following equation:

$$(2) E_S = \sin^2 \nu$$

and the P-polarization diffraction efficiency is given by the following equation:

$$(3) E_P = \sin^2(\nu \cos 2\theta).$$

So the S-polarization diffraction efficiency is a function only of ν , whereas the P-polarization diffraction efficiency is a function of both ν and 2θ , which is the angle between the incident beam 34 and the diffracted beam 36 within volume phase medium 32. The dependence on ν of the P-polarization diffraction efficiency produces the lag of E_P relative to E_S in the graph of diffraction efficiencies versus index modulation. The angle θ is determined

by the angle of incidence, θ_i , and the angle of diffraction, θ_d . As these angles increase, the lag will increase. Fig. 8 shows the S and P diffraction efficiency curves for angles of incidence and diffraction that are larger than those in the example of Fig. 7. Eventually, when the angle of incidence, θ_i , and the angle of diffraction, θ_d , are such that the angle between the two beams inside the medium, 2θ , is 90 degrees, the amount of lag will be infinite and the P diffraction efficiency will never rise above zero, no matter how large the value of Δn . In that case, the diffracted beam will be completely S-polarized.

Since the P efficiency lags the S efficiency, the two diffraction efficiencies are not, in general, maximum at the same value of Δn . In a VPG that is intended for use in a WDM application, this will result in three possible scenarios, none of which are desirable.

First, one could reduce the P-S lag by using relatively small angles of incidence and diffraction as has been done in the prior art. The S and P diffraction efficiency curves for this case are shown in Fig. 9. Note that the S and P diffraction efficiency curves intersect at a relatively high value of diffraction efficiency. Therefore, the S and P diffraction efficiencies will be equal and both diffraction efficiencies will be relatively high. The result will be reasonably low insertion loss and relatively low PDL across a fairly broad wavelength range. (Insertion loss is inversely related to the diffraction efficiency. PDL is directly related to the difference between the S and P diffraction efficiencies). The disadvantage of this approach is that the dispersion will be relatively low because the angles are relatively small. (The dispersion of a diffraction grating is directly related to the angle between the incident and diffracted beams.)

In a second case, the angles are increased in order to get more dispersion. Then we have the S and P diffraction efficiency curves similar to those shown in Fig. 7. One can then choose to operate at the peak of the S diffraction efficiency curve so that the insertion loss for S-polarization will be low. However, since the P diffraction efficiency is low at this value of Δn , the PDL will be very high.

In a third case, the angles are increased to provide very high dispersion so that we have the situation shown in Fig. 8. However, in this case, the choice is made to operate at the crossover point of the two curves in order to minimize the PDL. But both the S and P diffraction efficiencies will be low at this value of Δn . The net result is that this approach will provide very high dispersion and low PDL but very high insertion loss.

So the three cases just described provide (1) low insertion loss and low PDL but low dispersion; (2) low insertion loss and high dispersion but large PDL; or (3) high dispersion and low PDL but very high insertion loss. None of these three situations is optimal for WDM

applications. What is desired is (a) high dispersion, and (b) low insertion loss, and (c) low PDL.

One can achieve this desired combination if the angles of incidence and diffraction are selected so that the P diffraction efficiency curve reaches its first maximum when the S diffraction efficiency curve reaches its second maximum. This situation is shown in Fig. 10. In this case, the S and P diffraction efficiencies are both equal and both maximum so that the PDL is minimized. In addition, the angles at which this equalization occurs are relatively large so that the dispersion is also large. The net result is that the insertion loss is low, the PDL is low and the dispersion is high. That is, we have the desired combination of all three major grating parameters.

One can increase the dispersion even further by increasing the angles of incidence and diffraction until S and P maxima farther out along the Δn axis coincide. For example, one can select angles of incidence and diffraction so that the third peak of the S diffraction efficiency curve coincides with the first or second peak of the P diffraction efficiency curve, as shown in Fig. 11. This will provide greater dispersion and it will also allow the effective thickness, T, to be reduced (for a given index modulation, Δn). Higher order combinations are also possible but these combinations may be more difficult to fabricate.

In order for the S and P maxima to coincide, the values of E_s and E_p from equations (2) and (3) must be simultaneously equal to 1. E_s will be equal to 1 when $\nu = \frac{2s-1}{2}\pi$ and E_p will be equal to 1 when $\nu \cos(2\theta) = \frac{2p-1}{2}\pi$, where s and p are integers, 1, 2, 3, The value of $\cos(2\theta)$ at which the E_s and E_p maxima coincide can be found by simply solving the above two equations for $\cos(2\theta)$. The result is equation (4) below:

$$(4) \cos(2\theta) = (2p-1)/(2s-1)$$

(Since the cosine of an angle cannot be greater than 1 for any real angle, the integer, p, must always be less than the integer, s, in equation (4).)

where:

s is the order of the S diffraction efficiency peak (1, 2, 3, ...) and p is the order of the P diffraction efficiency peak (1, 2, 3, ...),

θ is the angle between the incident beam and the Bragg planes inside the medium
(A Bragg plane is a plane of maximum refractive index in the medium), and

- 5 2θ is the angle between the incident beam and the diffracted beam inside the medium.

Equation (1) can be re-arranged to provide an equation for the index modulation:

$$\Delta n = \frac{\nu\lambda}{\pi T} \sqrt{C_R C_S} .$$

10

But from the derivation of Equation (4) above we know that

$$\nu = \frac{2s-1}{2} \pi$$

- 15 when E_s is maximum. Therefore, when E_s is maximum,

$$\Delta n = \frac{\lambda}{T} \left(\frac{2s-1}{2} \right) \sqrt{C_R C_S}$$

where

20

$$C_R = \cos \alpha$$

$$C_S = \cos \alpha - \frac{\lambda}{nd} \tan\left(\frac{\beta - \alpha}{2}\right)$$

- 25 (See Kogelnik, H. "Coupled Wave Theory for Thick Hologram Gratings," Bell System Technical Journal, Vol. 48, No. 9, 1969, Equation 23).

The final result is:

$$(5) \quad \Delta n = \frac{\lambda}{T} \frac{2s-1}{2} \sqrt{C_R C_S} = \frac{\lambda}{T} \left(\frac{2s-1}{2} \right) \sqrt{(\cos \alpha) \left(\cos \alpha - \frac{\lambda}{nd} \tan\left(\frac{\beta - \alpha}{2}\right) \right)}$$

where all terms have been previously defined.

So the value of the index modulation, Δn , at which the S-polarization diffraction efficiency is maximum, for a given wavelength, index of refraction of the medium and effective thickness of the medium, is given by equation (5). Therefore, when equations (4) and (5) are satisfied simultaneously, the S and P diffraction efficiencies will be maximized simultaneously.

From Figure 6 it can be seen that $\alpha + \beta = 2\theta$, so that Equation (4) can be solved for β , the internal angle of diffraction, to yield:

10

$$(6) \quad \beta = a \cos\left(\frac{2p-1}{2s-1}\right) - \alpha$$

Therefore, for given values of the bulk refractive index, n , effective thickness, T and wavelength, λ , and arbitrarily selected values of the integers s and p and the internal angle of incidence, α , the value of the internal angle of diffraction, β , established by Eq. (6) and the value of the index modulation, Δn , established by Eq. 5 will result in simultaneously maximizing the S-polarization diffraction efficiency, E_s , and the P-polarization diffraction efficiency, E_p , at a common value of the index modulation, Δn .

This coincidence of the s th peak of the S-polarization diffraction efficiency curve and the p th peak of the P-polarization diffraction efficiency curve at a common value of the index modulation, Δn , is the major novel property of the Enhanced Volume Phase Grating. Figure 11 is an example of a Dickson grating where the third peak of the S-polarization diffraction efficiency curve coincides with the second peak of the P-polarization diffraction efficiency curve at an index modulation value of 0.21.

Note that coincidence of the s th peak of the S diffraction efficiency curve and the p th peak of the P diffraction efficiency curve will also occur when the following equation for β is satisfied:

$$(7) \quad \beta = 180 - a \cos\left(\frac{2p-1}{2s-1}\right) - \alpha$$

30

That is, the S and P diffraction efficiency peaks will coincide when the angle between the incident beam and the Bragg planes inside the medium is either θ or $90-\theta$. In other words, the two angles will lie equally to either side of the zero-P-efficiency angle of 45 degrees. The second angle will generally exceed the internal angle of total internal reflection (TIR) if the substrate is parallel to the VPG medium and the external medium is air. This problem can be overcome by using a dual-prism grism design such as that shown in Fig. 15. This type of design allows the angles of incidence and diffraction inside the medium to exceed the normal TIR angle.

The required value of the index modulation, Δn , will be dependent on the effective thickness, T , the wavelength, λ , and the two obliquity factors, C_R and C_S . The values of the obliquity factors will be dependent on the bulk index of the medium and the external angles of incidence and diffraction, as established by the Kogelnik theory.

As an example of the design process for a Dickson grating, consider the simplest case, where $s = 2$ and $p = 1$. Not only is this the simplest Dickson grating design, it is also the easiest Dickson grating to fabricate.

Note that the selection of the integer values of s and p in design of a Dickson grating is completely arbitrary, so long as $s > p$. The design process would be identical for any combination of s and p integers. Dickson gratings resulting from a selection of larger values of s and p would have greater dispersion but would be more difficult to fabricate and would typically require the use of external prisms.

Each Dickson grating included in the inventive multi-HOE grating is preferably implemented to have uniformly high diffraction efficiency across a broad wavelength range (including a nominal wavelength) for all polarizations and is implemented (and oriented during use) with the bulk index and index modulation (and optionally also the thickness or effective thickness) of its volume phase material, and angles of incidence and diffraction of the radiation to be diffracted thereby, such that its diffraction efficiency for both S-polarization and P-polarization are simultaneously maximized at the nominal wavelength. The volume phase material of each such Dickson grating is created, coated, exposed and processed so as to obtain the desired values of these major parameters.

When the angles of incidence and diffraction within the substrate media are such that they exceed the TIR angle, then the multi-HOE grating must include an entrance and exit prism.

Once s and p are selected ($s = 2$ and $p = 1$ in the example), the angle of incidence, θ_i , must be selected. The angle of incidence, θ_i , can be selected to provide a symmetric grating design, where the angle of diffraction, θ_d , is equal to the angle of incidence, θ_i , or a non-symmetric grating design, where the angle of diffraction, θ_d , is not equal to the angle of incidence, θ_i . The choice is generally governed by other factors in the overall system design.

Once θ_i is established, the internal angle of incidence, α , can be determined using the well known Snell's Law and the known bulk refractive index, n , of the volume phase medium. Then, once this internal angle of incidence, α , is determined, equation (6) can be used to establish the internal angle of diffraction, β . Then Snell's Law can be used to determine the external angle of diffraction, θ_d .

Knowing the internal angle of incidence, α , the internal angle of diffraction, β , the bulk refractive index, n , of the volume phase medium and the free space wavelength, λ , of the incident beam, one can use the following equation, which is a transposition of the grating equation noted earlier, to determine the grating period, d :

$$(8) \quad d = \frac{\lambda}{n(\sin \alpha + \sin \beta)}.$$

Furthermore, knowing the external angle of incidence, θ_i , and the external angle of diffraction, θ_d , the construction illumination geometry of a Dickson grating can be established. In fact, if the application wavelength and the construction wavelength for a Dickson grating are the same, then θ_i and $180 + \theta_d$ will be the construction angles for the laser beams used in constructing the Dickson grating. If the construction wavelength is not the same as the application wavelength, as is often the case, then the construction angles must be modified in accordance with procedures that are well known in the art of fabrication of volume phase gratings (for example, following the teachings of US patents 6,085,980 and 6,112,990).

The final step in the fabrication process of a Dickson grating is to expose and process the grating so that the peak index modulation, Δn , is equal to the value calculated in equation (5). Exposure and processing methods to accomplish this are well known in the art (See, for example, Chang, M. "Dichromated Gelatin of Improved Quality", Applied Optics, Vol. 10, p.

2250, 1971 and Meyerhofer, D. "Phase Holograms in Dichromated Gelatin," RCA Review, Vol. 35, p. 110, 1972.)

Note: In an alternative design process, one can select a value for the external angle of diffraction, θ_d , and use Snell's Law to determine the internal angle of diffraction, β ,
5 equation (6) to determine the internal angle of incidence angle, α and Snell's Law to determine the external angle of incidence, θ_i . The construction process and the procedure to establish the peak index modulation, Δn , would be the same as for the case where the angle of incidence, θ_i , was selected at the outset.

Satisfying equations (5) and (6) is sufficient to obtain high diffraction efficiency for
10 both polarizations simultaneously. And the angles needed to satisfy the second of these two equations will result in high dispersion. However, there is a fourth requirement for a WDM grating. The fourth requirement is that the WDM application requires low insertion loss and low PDL across the full width of the relevant telecommunications passband. E.g., for the C band, the insertion loss and the PDL must be acceptably low over the full wavelength range
15 from 1528 nm to 1565 nm. The fourth requirement is met by Dickson gratings, having Δn on the order of 0.2 (i.e., $0.17 \leq \Delta n \leq 0.22$) or greater (e.g., $\Delta n = 0.26$), and designed in accordance with referenced U.S. Patent 6,750,995. However, the fourth requirement could not be met by conventional VPGs (that are not Dickson gratings having Δn on the order of 0.2 or greater) because of the high Bragg angle sensitivity that would result when the
20 necessary design criteria are met. Bragg angle sensitivity is the variation of diffraction efficiency as a function of either the wavelength or the angle of incidence of the incident beam.

In a conventional VPG, Δn is typically in the range of 0.05 to 0.08. In order to satisfy equation (2) an effective thickness on the order of 25 to 35 microns would be required (for
25 the volume phase medium of such a conventional VPG). It is well known that Bragg angle sensitivity is a strong function of the effective thickness of the medium. Fig. 12 shows the variation of S and P diffraction efficiencies for a conventional VPG having an effective medium thickness of 35 microns. The Bragg angle sensitivity is quite large and the resulting PDL at the ends of the passbands is totally unacceptable for WDM applications.

30 To implement a Dickson grating (whose volume phase medium is DCG) so as to solve the final problem (i.e., to achieve low insertion loss and low PDL across a wide range of wavelengths of incident radiation, for example, across the full width of a telecommunications passband, without excessive Bragg angle sensitivity), the volume phase

medium of the Dickson grating is exposed and processed to achieve a Δn on the order of 0.2 (i.e., $0.17 \leq \Delta n \leq 0.22$) or greater (e.g., $\Delta n = 0.26$). Processing procedures for DCG are well known in the art and processing for high Δn , while difficult, is an extension of known DCG processing methods. To manufacture a typical implementation of a Dickson grating that
5 solves the final problem, the volume phase medium (DCG) is spin coated on a glass or fused silica substrate to a physical thickness that is on the order of 15 microns. The volume phase medium is exposed in a conventional dual-beam holographic grating fabrication process using a laser with a wavelength to which the DCG is responsive. It is then processed in a sequence of alcohol water baths using well-known DCG processing procedures. After drying
10 and edge stripping to provide an adhesive o-ring seal when capped, the actual gratings are then diced from the larger grating, and then sealed (capped) with a cover glass. The exposure and processing of the DCG yields a final effective thickness (of the volume phase medium) of approximately 9 to 10 microns.

Fig. 13 shows the S and P diffraction efficiency curves for one example of a Dickson
15 grating whose volume phase medium is DCG (processed as explained in the preceding paragraph) having an effective thickness of 9 microns, and which is designed for use such that the angles of incidence and diffraction satisfy equation (4). The post-processing bulk refractive index of the volume phase medium is approximately 1.27, but may vary from 1.2 or less to 1.4 or greater.

Fig. 14 shows the variation of the S and P diffraction efficiencies as functions of
20 wavelength for the Dickson grating of Fig. 13. Note that both efficiencies fall off only slightly to either side of the nominal wavelength and the difference in falloff of the two polarizations is very small so that PDL will be low across the full bandwidth.

The design of the Dickson grating of Figs. 13 and 14 satisfies all of the major
25 requirements for an effective diffraction grating for WDM applications - high dispersion, low insertion loss, low PDL - all across the full passband.

Some implementations of Dickson gratings have higher numbers for p and s in
Equations 4 and 5, and thus have higher dispersion than the grating described above. Typically, higher p and s numbers will require the use of a grism design (where "grism"
30 denotes an optical element that includes a diffraction grating and at least one prism).

A Dickson grating having a grism design is shown in Fig. 15. A first prism 50 is attached to entrance surface 64 of the grating's volume phase medium 52 and a second prism 54 is attached to exit surface 68 of volume phase medium 52. The incident beam 56 may be normal to the entrance surface 58 of the prism 50 or it may be at some non-normal angle,

depending on the design requirements of the grating and the system in which it is to be used. Similarly, the exit beam 62 may be normal to the exit surface 60 of the second prism or it may be at some non-normal angle, depending on the design requirements of the grating and the system in which it is to be used. The two prisms are not necessarily equal in geometric shape or refractive index. In the extreme, the refractive index of one of the prisms could be 1, so that the two-prism embodiment becomes a single-prism embodiment.

A prism is typically required for higher order grating designs (larger values of s and p) but it may also be advantageous in the primary order design for packaging reasons or mechanical stability.

A further embodiment of a Dickson grating is shown in Fig. 16. This embodiment is similar to that shown in Fig. 15 but with the addition of a mirror 84 attached to the final surface 80 of the exit prism 74. The mirror 84 reflects the diffracted beam 89 back into the grating 72 for a second pass 90, thereby increasing the overall dispersion. The double-pass design concept for conventional (non-enhanced) volume phase gratings has been described in the prior art.

In a variation on the Fig. 16 embodiment, exit prism 74 is omitted (so that the device includes only Dickson grating 72, prism 70, and mirror 84 in contact with Dickson grating 72). In an implementation of such a variation, the spatial frequency of the Dickson grating is 780.5 lines per mm.

A further embodiment of a Dickson grating is shown in Fig. 17. This embodiment includes a mirror 98 attached to, or located in the vicinity of, the final surface 102 of the grating 92. The mirror 98 reflects the diffracted beam 91, back into the grating at, or near, normal incidence for a second pass 94, through the grating 92 thereby more than doubling the dispersion. Such a design functions like a Littrow grating, but with higher dispersion for a given grating spatial frequency.

In an implementation of the Dickson grating of Fig. 6, substrate 42 and cover 26 are both coated with an anti-reflection (AR) coating so that at the nominal wavelength, λ , the overall loss for S-polarization is slightly greater than the overall loss for P-polarization. The resultant S and P wavelength Bragg sensitivity curves are shown in Fig. 18. Note that the PDL is now non-zero at the nominal wavelength but it is also less at the wavelengths corresponding to the ends of the passband. That is, the worst-case PDL has been reduced.

In another variation on the Fig. 6 embodiment of a Dickson grating, substrate 42 and cover 26 are both coated with an AR coating so that at the nominal wavelength, λ , the overall loss for S-polarization is greater than the overall loss for P-polarization by an amount that is

greater than that of the prior extension discussed above. This additional loss improves the performance of the Dickson grating in a two-pass design. This can be seen in Fig. 19. This graph shows the variation in the S and P diffraction efficiencies as a function of the angle of incidence of the beam. In a two-pass design, the angle of incidence at the second pass through the grating varies as a function of the wavelength due to the dispersion resulting from the first pass through the grating. At the extremes of the passband, the angle of incidence will be such as to lower the S and P diffraction efficiencies. Increasing the nominal loss for the S beam, as shown, will reduce the worst case PDL.

In a preferred implementations of the Dickson grating of Fig. 6, the angle of incidence, α , in volume phase medium 32 equals the angle of diffraction, β , in volume phase medium 32 at the nominal wavelength, λ . These particular implementations have two significant advantages: (a) the dispersion will be maximized compared to other combinations of angles that satisfy equations (4) and (5); (b) the Bragg surfaces 46 will be normal to the surface 40 of the substrate 42, which simplifies the fabrication process. However, implementations in which the angles α and β are not equal may have geometric or other advantages.

Typically, each constituent grating of the inventive multi-HOE grating is a holographic grating whose volume phase material is a hologram consisting essentially of dichromated gelatin ("DCG"). Alternatively, the constituent gratings of the inventive multi-HOE grating consist of material and/or have structure other than the material and/or structure of the gratings of such typical embodiments. For example, in some embodiments, at least one constituent grating includes or consists of a suitable polymer or Lithium Niobate. In some embodiments, constituent elements of the inventive grating need not be (and are not) bonded together (e.g., by optical cement or otherwise), and/or the constituent elements (or the overall device) need not be (and are not) sealed. In various embodiments, the substrate and/or cover materials of the inventive multi-HOE grating include (or consist of) plastic, glass or other suitable material, which is typically (but need not be) transparent. In some embodiments, the inventive multi-HOE grating does not require (and does not include) a substrate and/or cover material to support and/or protect its constituent gratings.

While examples of the present invention and applications of the invention have been described herein, it will be apparent to those of ordinary skill in the art that many variations on the embodiments and applications described herein are possible without departing from the scope of the invention described and claimed herein. It should be understood that while

certain forms of the invention have been shown and described, the invention is not to be limited to the specific embodiments described and shown or the specific methods described.

WHAT IS CLAIMED IS:

1. A multi-element diffraction grating configured to diffract incident radiation with high dispersion using at least two holographic optical elements, said multi-element diffraction grating including:

a Dickson grating having refractive index modulations of a first spatial frequency, wherein the Dickson grating is one of the holographic optical elements; and

at least one additional volume phase grating, wherein each said additional volume phase grating is another one of the holographic optical elements, the Dickson grating and each said additional volume phase grating are positioned relative to each other such that the radiation propagates through and is diffracted by said Dickson grating and each said additional volume phase grating, and each said additional volume phase grating has refractive index modulations of spatial frequency significantly lower than the first spatial frequency.

2. The multi-element diffraction grating of claim 1, wherein each said additional volume phase grating is a non-Dickson grating.

3. The multi-element diffraction grating of claim 2, wherein the Dickson grating has a first polarization dependent loss, the incident radiation has both S-polarized components and P-polarized components having a range of wavelengths, and the refractive index modulations of each said non-Dickson grating have spatial frequency sufficiently lower than the first spatial frequency so that the multi-element diffraction grating has polarization dependent loss that does not differ significantly from the first polarization dependent loss and has at least substantially uniform diffraction efficiency across the range of wavelengths for the S-polarized components and the P-polarized components of the incident radiation.

4. The multi-element diffraction grating of claim 2, wherein the incident radiation includes components whose wavelengths are in a range including the wavelength 1546 nm and having bandwidth at least substantially equal to 37 nm, the multi-element diffraction grating includes only one said non-Dickson grating, the non-Dickson grating has a spatial frequency at least substantially equal to 448 lines per mm, the Dickson grating has a spatial frequency at least substantially equal to 902 lines per mm, and the multi-element diffraction grating also includes:

a first prism; and

a second prism, wherein the Dickson grating is positioned between the first prism and the second prism, and the non-Dickson grating is positioned between the first prism and the Dickson grating.

5 5. The multi-element diffraction grating of claim 1, wherein the first spatial frequency is greater by at least a factor of two than the spatial frequency of the refractive index modulations of each said additional volume phase grating.

10 6. The multi-element diffraction grating of claim 1, including only one additional volume phase grating, wherein the first spatial frequency is A lines per mm, the spatial frequency of the refractive index modulations of the additional volume phase grating is B lines per mm, and the multi-element diffraction grating is configured to diffract the incident radiation with at least as much dispersion as would a second volume phase grating designed and configured to diffract the same radiation, said second volume phase grating having
15 refractive index modulations whose spatial frequency is at least substantially equal to (A+B) lines per mm.

20 7. The multi-element diffraction grating of claim 1, wherein each of the Dickson grating and each said additional volume phase grating is a non-symmetric grating.

 8. The multi-element diffraction grating of claim 1, also including at least one prism positioned relative to the Dickson grating and each said additional volume phase grating so that the radiation propagates through each said prism.

25 9. The multi-element diffraction grating of claim 1, also including:
 a first prism; and
 a second prism, wherein the Dickson grating is positioned between the first prism and the second prism, and the additional volume phase grating is positioned between the first prism and the Dickson grating.

30 10. The multi-element diffraction grating of claim 1, wherein said multi-element diffraction grating is a transmissive grating.

11. The multi-element diffraction grating of claim 1, wherein said multi-element diffraction grating is a reflective grating.

12. The multi-element diffraction grating of claim 1, wherein each of the Dickson grating and the additional volume phase grating includes volume phase material consisting essentially of dichromated gelatin.

13. The multi-element diffraction grating of claim 1, wherein the Dickson grating comprises:

10 a volume phase medium having a thickness, T, a surface, and a bulk refractive index, wherein the bulk refractive index is periodically modulated in a direction parallel to the surface of the volume phase medium, with a peak value of refractive index equal to $n + \Delta n$, where Δn is the peak modulation of said bulk refractive index and n is a refractive index, a periodic sequence of peak values of said bulk refractive index throughout the thickness of the
15 volume phase medium provides a periodic structure of Bragg surfaces within said volume phase medium with a period, d, where the period, d, satisfies

$$d = \frac{\lambda}{n(\sin \alpha + \sin \beta)},$$

20 where λ is the nominal free-space wavelength for which said Dickson grating is designed,

$$\Delta n = \frac{\lambda}{T} \left(\frac{2s-1}{2} \right) \sqrt{(\cos \alpha) \left(\cos \alpha - \frac{\lambda}{nd} \tan \left(\frac{\beta - \alpha}{2} \right) \right)},$$

where s is a positive integer satisfying $s > p$, p is another positive integer,

25 θ_i is an arbitrary external angle of incidence, and

β is an internal angle of diffraction that satisfies

$$\beta = a \cos \left(\frac{2p-1}{2s-1} \right) - \alpha,$$

30 where $\alpha = a \sin \left(\frac{\sin \theta_i}{n} \right)$.

14. The multi-element diffraction grating of claim 1, wherein the Dickson grating comprises:

a volume phase medium having a thickness, T, a surface, and a bulk refractive index, wherein the bulk refractive index is periodically modulated in a direction parallel to the surface of the volume phase medium, with a peak value of refractive index equal to $n + \Delta n$, where Δn is the peak modulation of said bulk refractive index and n is a refractive index, a periodic sequence of peak values of said bulk refractive index throughout the thickness of the volume phase medium provides a periodic structure of Bragg surfaces within said volume phase medium with a period, d, where the period, d, satisfies

$$d = \frac{\lambda}{n(\sin \alpha + \sin \beta)},$$

where λ is the nominal free-space wavelength for which said Dickson grating is designed,

$$\Delta n = \frac{\lambda}{T} \left(\frac{2s-1}{2} \right) \sqrt{(\cos \alpha) \left(\cos \alpha - \frac{\lambda}{nd} \tan \left(\frac{\beta - \alpha}{2} \right) \right)},$$

where s is a positive integer satisfying $s > p$, p is another positive integer,

θ_i is an arbitrary external angle of incidence, and

β is an internal angle of diffraction that satisfies

$$\beta = 180 - a \cos \left(\frac{2p-1}{2s-1} \right) - \alpha,$$

where $\alpha = a \sin \left(\frac{\sin \theta_i}{n} \right)$.

15. A multi-element diffraction grating configured to diffract incident radiation with high dispersion, said multi-element diffraction grating including:

a Dickson grating whose volume phase medium has refractive index modulations of a first spatial frequency, said Dickson grating having a first surface and a second surface;

a volume phase grating whose volume phase medium has refractive index modulations of a second spatial frequency, said volume phase grating having a first surface and a second surface; and

5 adhesive between the Dickson grating and the volume phase grating, said adhesive coupling the Dickson grating's second surface to the volume phase grating's second surface, wherein the second spatial frequency is significantly lower than the first spatial frequency.

10 16. The multi-element diffraction grating of claim 15, wherein the volume phase grating is a non-Dickson grating.

15 17. The multi-element diffraction grating of claim 16, wherein the Dickson grating has a first polarization dependent loss, the incident radiation has both S-polarized components and P-polarized components having a range of wavelengths, and the second spatial frequency is sufficiently lower than the first spatial frequency so that the multi-element diffraction grating has a polarization dependent loss that does not differ significantly from the first polarization dependent loss and has at least substantially uniform diffraction efficiency across the range of wavelengths for the S-polarized components and the P-polarized components of the incident radiation.

20 18. The multi-element diffraction grating of claim 16, wherein the incident radiation includes components whose wavelengths are in a range including the wavelength 1546 nm and having bandwidth at least substantially equal to 37 nm, the non-Dickson grating has a spatial frequency at least substantially equal to 448 lines per mm, the Dickson grating has a spatial frequency at least substantially equal to 902 lines per mm, and the multi-element
25 diffraction grating also includes:

a first prism; and

a second prism, wherein the Dickson grating is positioned between the first prism and the second prism, and the non-Dickson grating is positioned between the first prism and the
30 Dickson grating.

19. The multi-element diffraction grating of claim 15, wherein the first spatial frequency is greater by at least a factor of two than the second spatial frequency.

20. The multi-element diffraction grating of claim 15, wherein each of the Dickson grating and the volume phase grating is a non-symmetric grating.

21. The multi-element diffraction grating of claim 15, also including:
5 a prism coupled to the first surface of the Dickson grating.

22. The multi-element diffraction grating of claim 21, also including:
a second prism coupled to the first surface of the volume phase grating.

10 23. The multi-element diffraction grating of claim 15, wherein said multi-element diffraction grating is a transmissive grating.

24. The multi-element diffraction grating of claim 15, wherein said multi-element diffraction grating is a reflective grating.

15 25. The multi-element diffraction grating of claim 15, wherein each of the Dickson grating and the volume phase grating includes volume phase material consisting essentially of dichromated gelatin.

20 26. The multi-element diffraction grating of claim 15, wherein the Dickson grating comprises: a volume phase medium having a thickness, T , a surface, and a bulk refractive index, wherein the bulk refractive index is periodically modulated in a direction parallel to the surface of the volume phase medium, with a peak value of refractive index equal to $n + \Delta n$, where Δn is the peak modulation of said bulk refractive index and n is a refractive
25 index, a periodic sequence of peak values of said bulk refractive index throughout the thickness of the volume phase medium provides a periodic structure of Bragg surfaces within said volume phase medium with a period, d , where the period, d , satisfies

$$d = \frac{\lambda}{n(\sin \alpha + \sin \beta)},$$

30 where λ is the nominal free-space wavelength for which said Dickson grating is designed,

$$\Delta n = \frac{\lambda}{T} \left(\frac{2s-1}{2} \right) \sqrt{(\cos \alpha) \left(\cos \alpha - \frac{\lambda}{nd} \tan \left(\frac{\beta - \alpha}{2} \right) \right)},$$

where s is a positive integer satisfying $s > p$, p is another positive integer,

θ_i is an arbitrary external angle of incidence, and

5 β is an internal angle of diffraction that satisfies

$$\beta = a \cos \left(\frac{2p-1}{2s-1} \right) - \alpha,$$

where $\alpha = a \sin \left(\frac{\sin \theta_i}{n} \right).$

10

27. The multi-element diffraction grating of claim 15, wherein the Dickson grating comprises:

a volume phase medium having a thickness, T , a surface, and a bulk refractive index, wherein the bulk refractive index is periodically modulated in a direction parallel to the surface of the volume phase medium, with a peak value of refractive index equal to $n + \Delta n$, where Δn is the peak modulation of said bulk refractive index and n is a refractive index, a periodic sequence of peak values of said bulk refractive index throughout the thickness of the volume phase medium provides a periodic structure of Bragg surfaces within said volume phase medium with a period, d , where the period, d , satisfies

20

$$d = \frac{\lambda}{n(\sin \alpha + \sin \beta)},$$

where λ is the nominal free-space wavelength for which said Dickson grating is designed,

25
$$\Delta n = \frac{\lambda}{T} \left(\frac{2s-1}{2} \right) \sqrt{(\cos \alpha) \left(\cos \alpha - \frac{\lambda}{nd} \tan \left(\frac{\beta - \alpha}{2} \right) \right)},$$

where s is a positive integer satisfying $s > p$, p is another positive integer,

θ_i is an arbitrary external angle of incidence, and

β is an internal angle of diffraction that satisfies

$$\beta = 180 - a \cos\left(\frac{2p-1}{2s-1}\right) - \alpha,$$

5 where $\alpha = a \sin\left(\frac{\sin\theta_i}{n}\right).$

28. A multi-element diffraction grating configured to diffract incident radiation with high dispersion using at least two holographic optical elements, said multi-element diffraction grating including:

10 a Dickson grating, wherein the Dickson grating is one of the holographic optical elements; and

at least one additional volume phase grating, wherein each said additional volume phase grating is another one of the holographic optical elements, each of the Dickson grating and each said additional volume phase grating is a non-symmetric grating, the Dickson
15 grating and each said additional volume phase grating are positioned relative to each other such that the radiation propagates through and is diffracted by said Dickson grating and each said additional volume phase grating, one of the Dickson grating and each said additional volume phase grating is a first grating at which the radiation is incident before it is incident at any other one of the Dickson grating and each said additional volume phase grating, another
20 one of the Dickson grating and each said additional volume phase grating is a last grating from which the radiation exits after exiting from each other one of the Dickson grating and each said additional volume phase grating, and Bragg planes of the first grating and the last grating are oriented such that the first grating has an entrance beam angle that matches the last grating's exit beam angle and such that the first grating has an exit beam angle that
25 matches the last grating's entrance beam angle.

29. The multi-element diffraction grating of claim 28, wherein the multi-element diffraction grating includes only one said additional volume phase grating, and said additional volume phase grating is a non-Dickson grating.

30

30. The multi-element diffraction grating of claim 29, wherein the Dickson grating is bonded directly to the non-Dickson grating.

31. The multi-element diffraction grating of claim 28, wherein the multi-element diffraction grating includes only one said additional volume phase grating, and said additional volume phase grating is a second Dickson grating.

5 32. The multi-element diffraction grating of claim 31, wherein the Dickson grating is bonded directly to the second Dickson grating.

Sheet 1/20

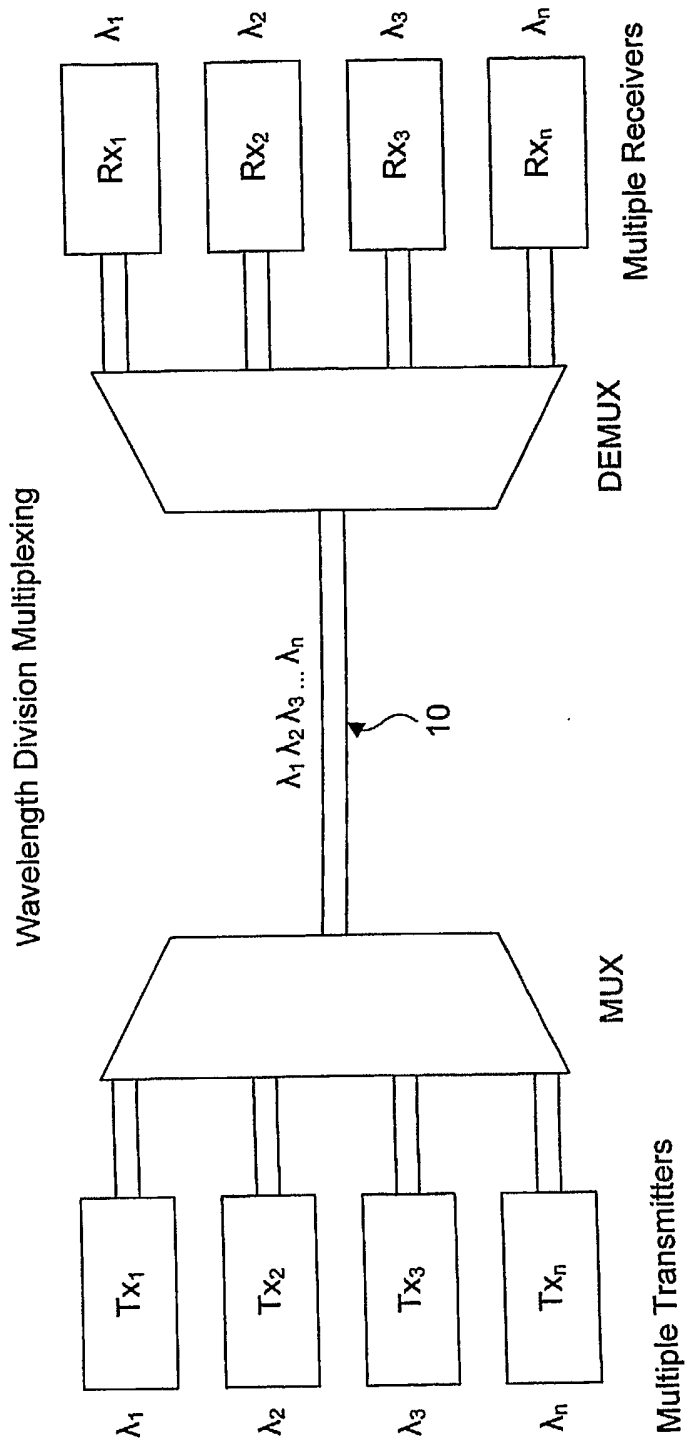

FIG. 1

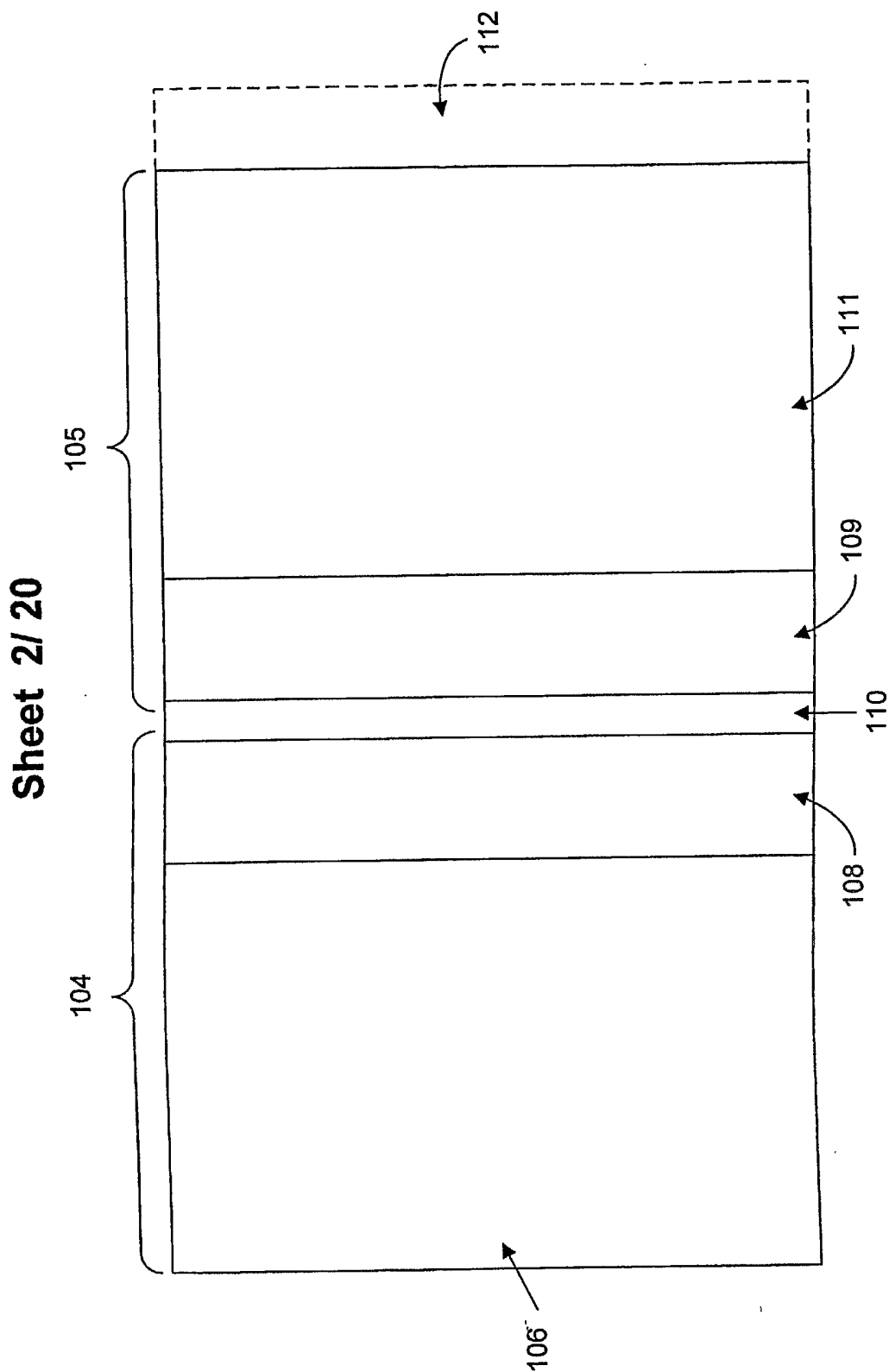

FIG. 2

Sheet 3/20

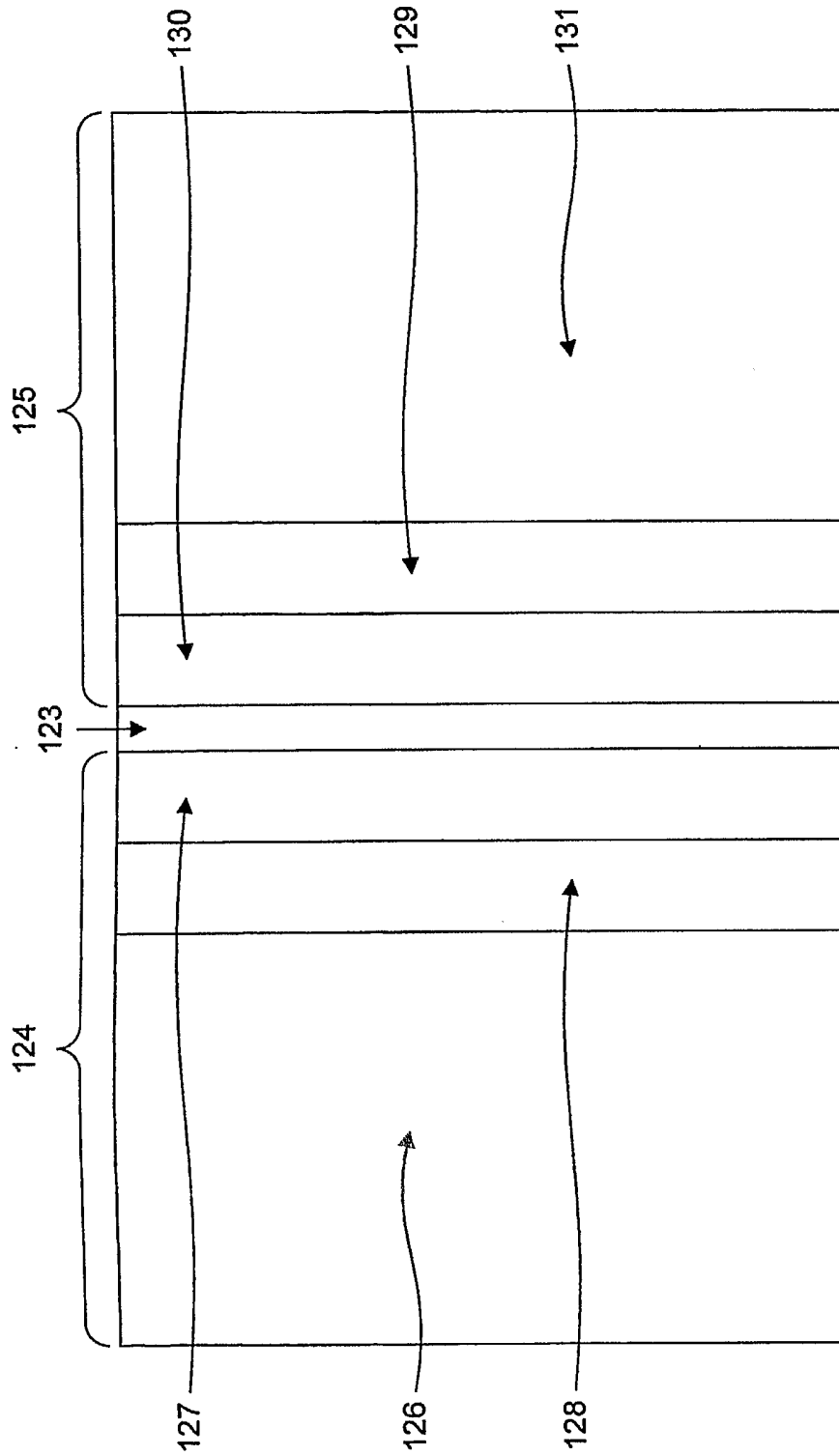

FIG. 3

Sheet 4/ 20

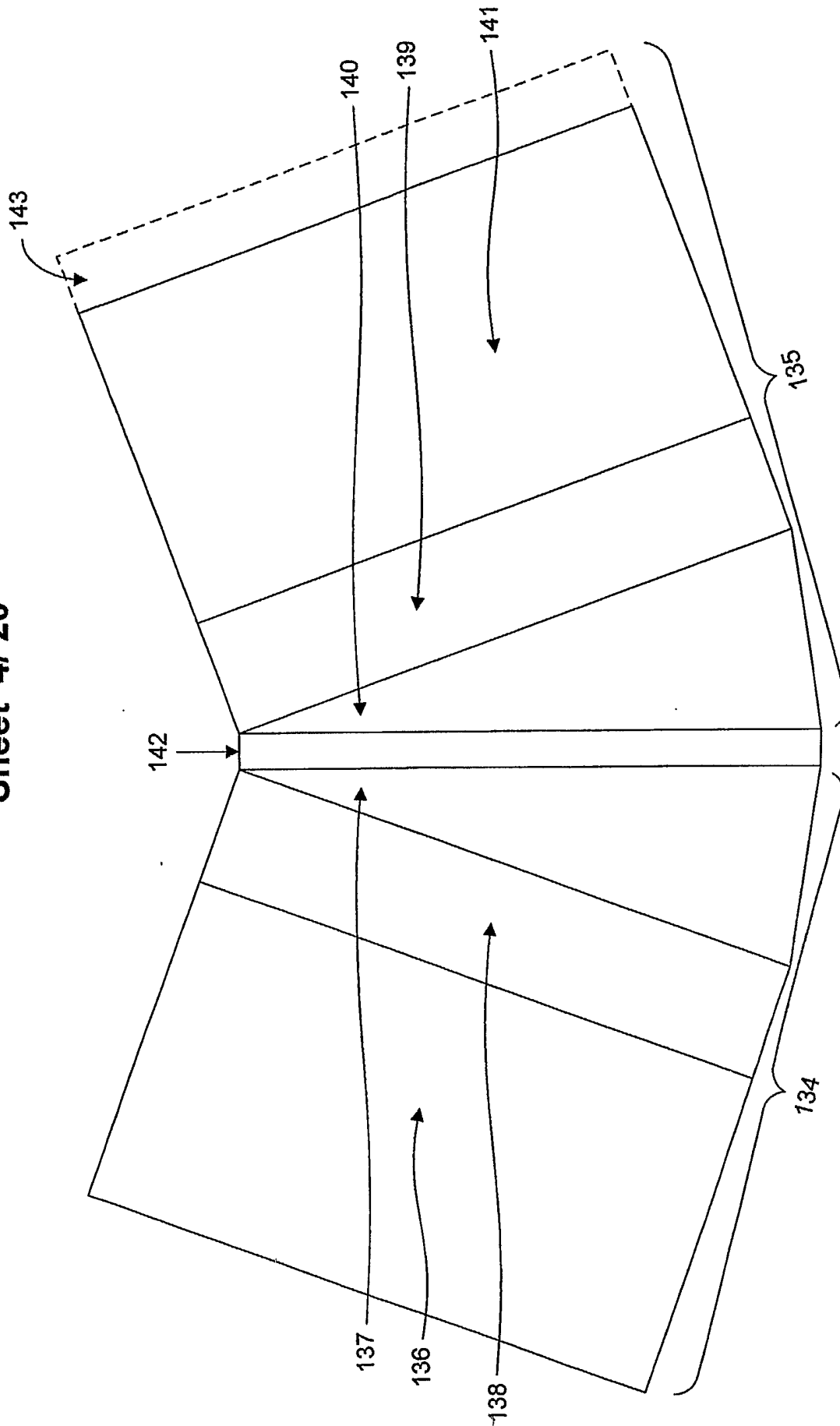

FIG. 4

SUBSTITUTE SHEET (RULE 26)

Sheet 5/20

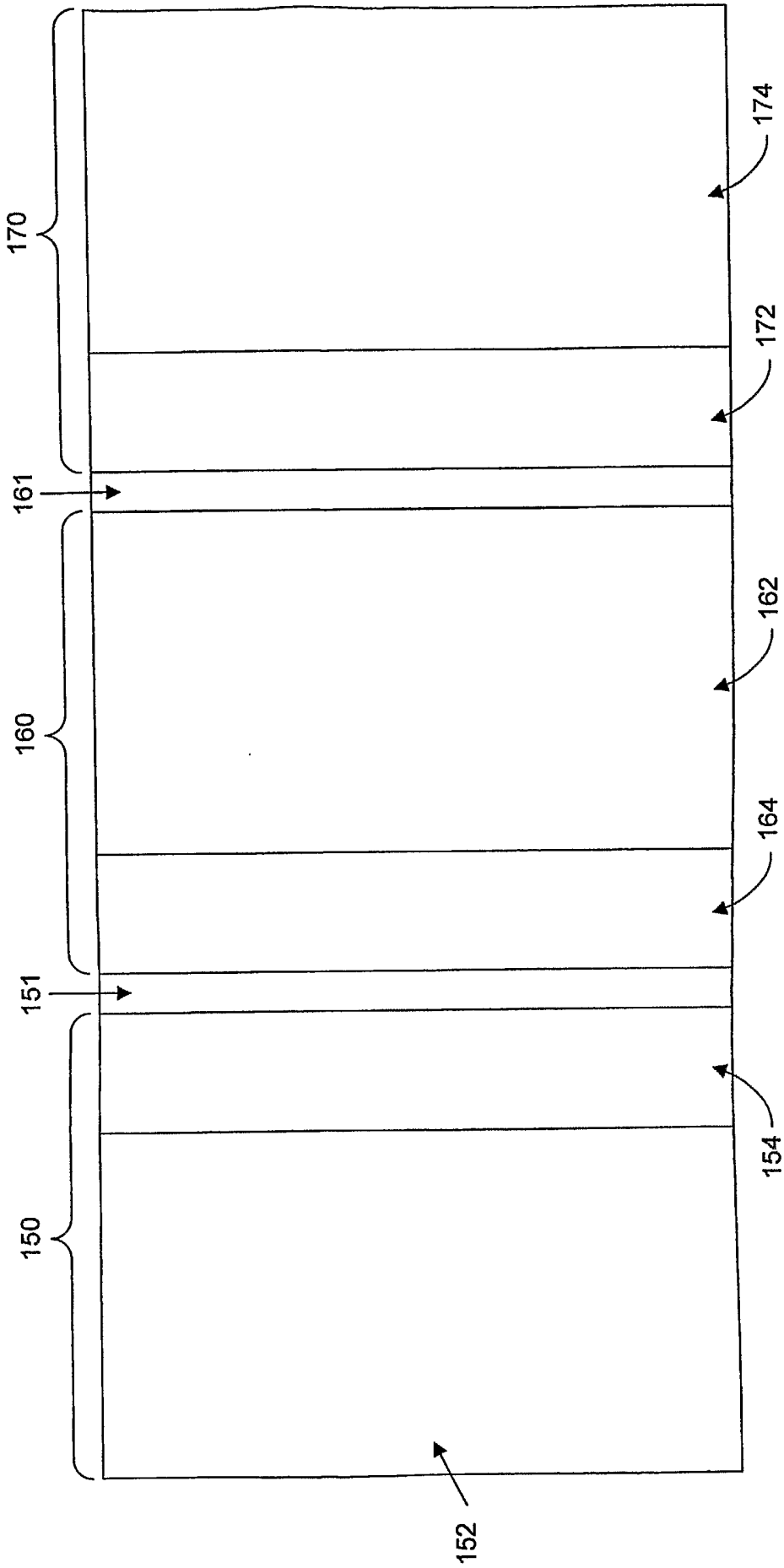

FIG. 5

SUBSTITUTE SHEET (RULE 26)

Sheet 6/20

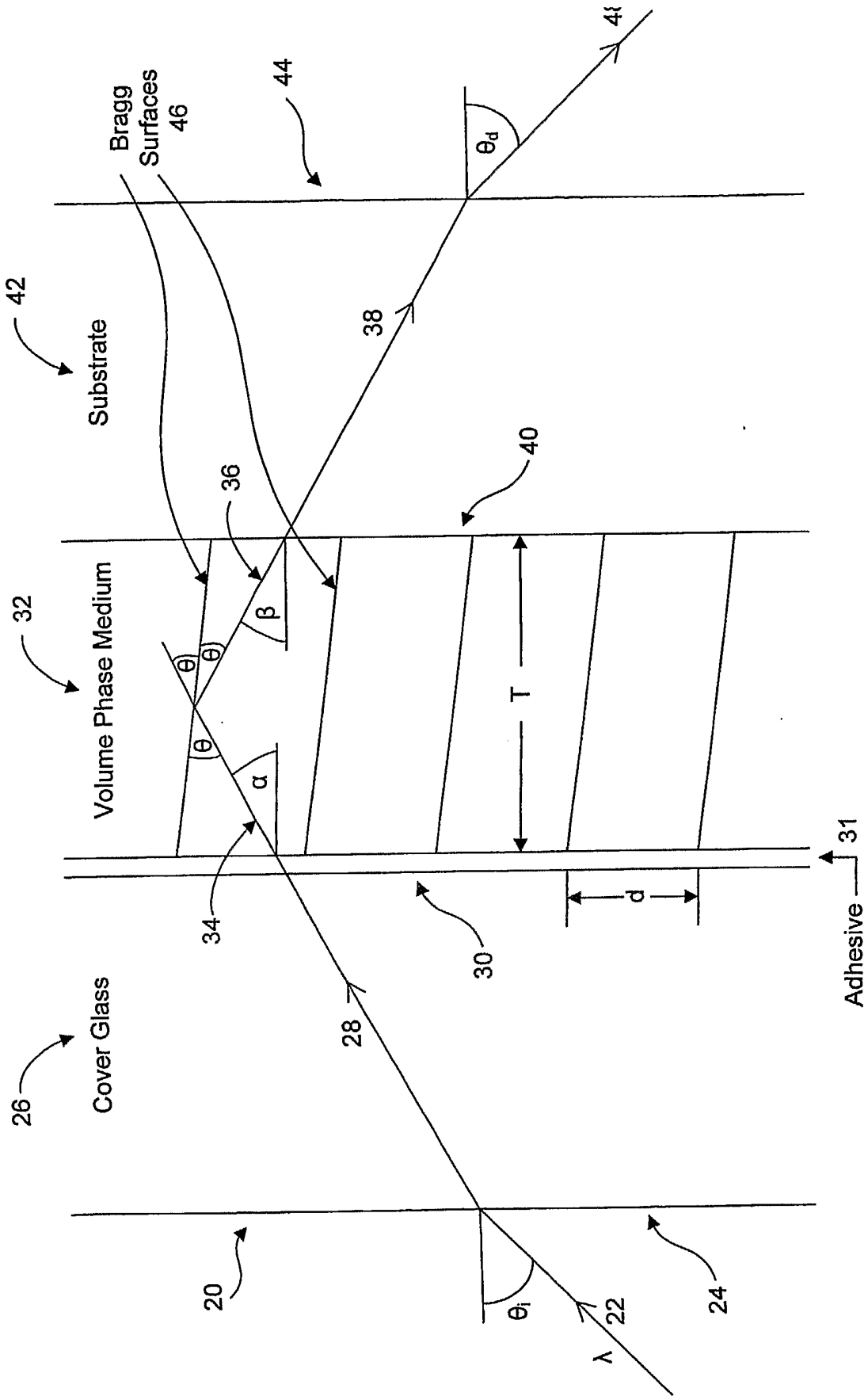

FIG. 6

Sheet 7/20

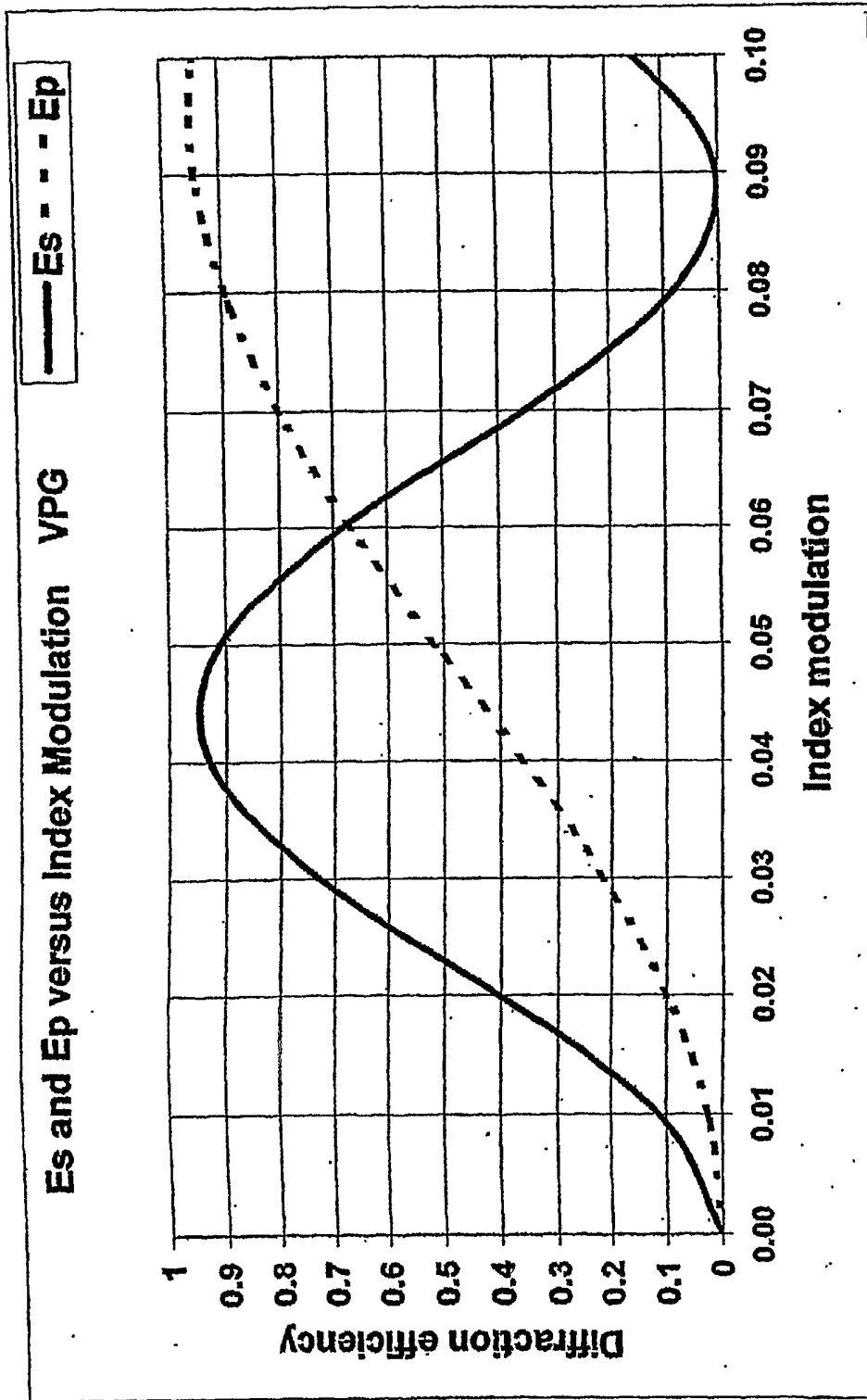

FIG. 7

Sheet 8/20

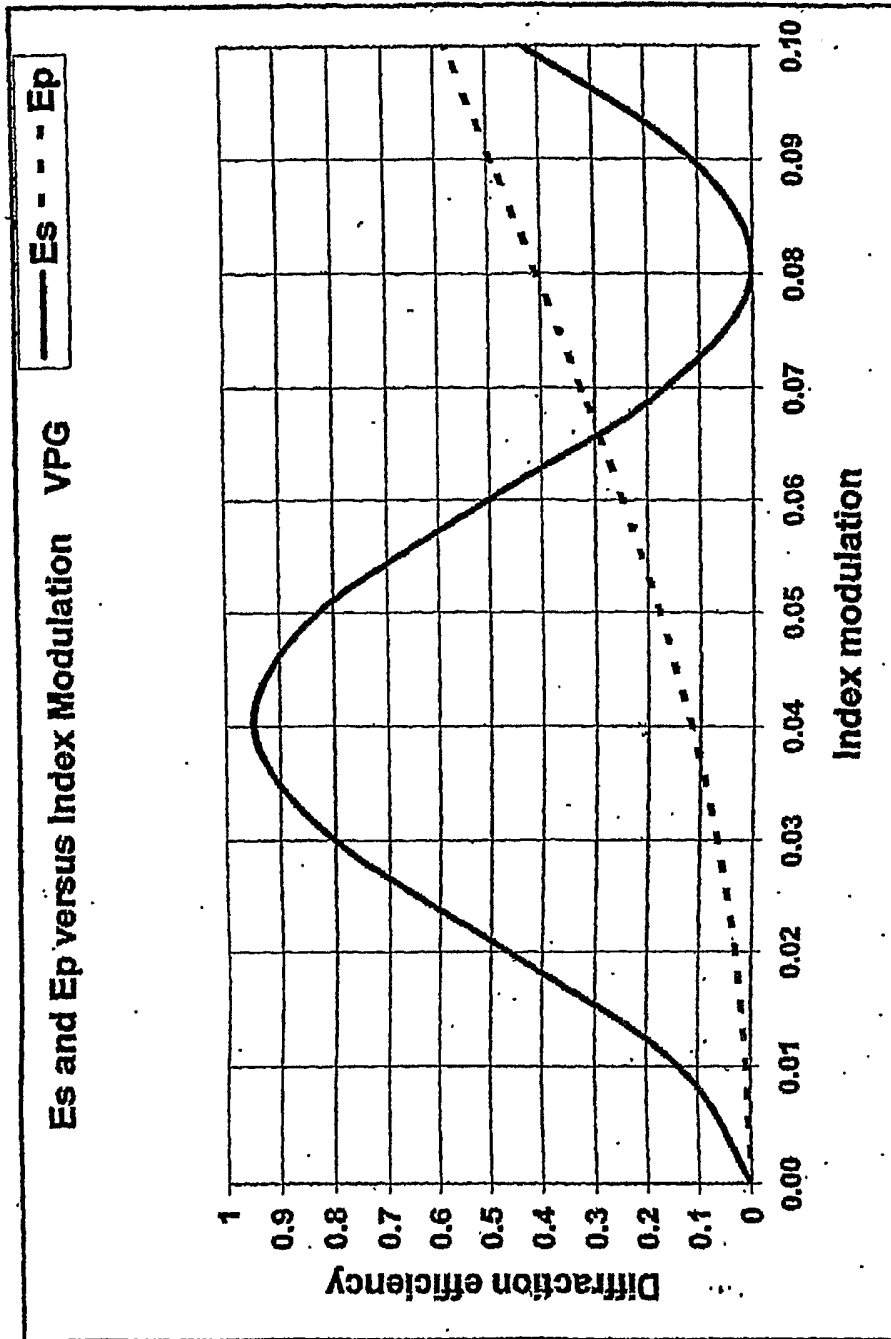

FIG. 8

Sheet 9/20

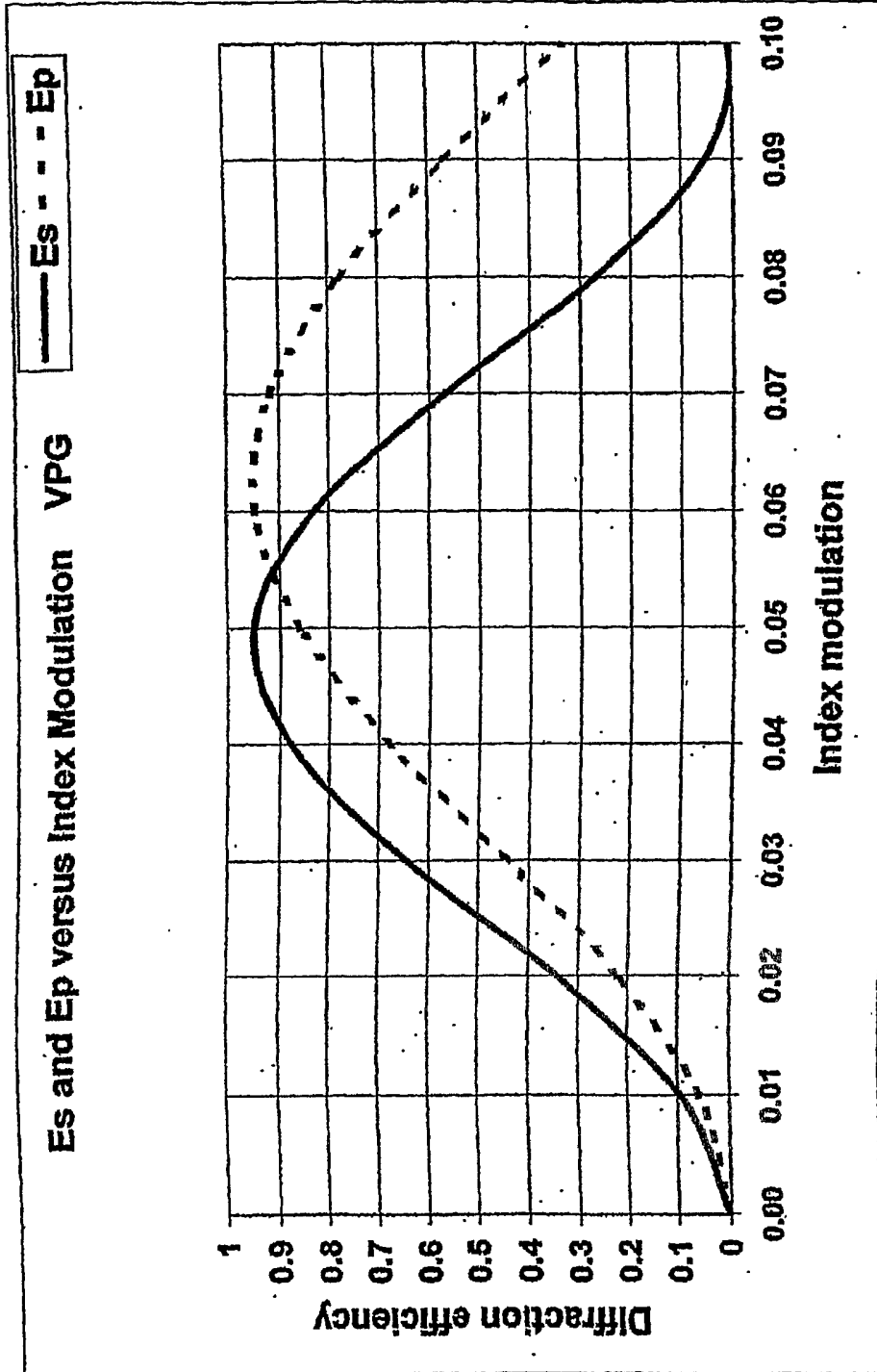

FIG. 9

Sheet 10/20

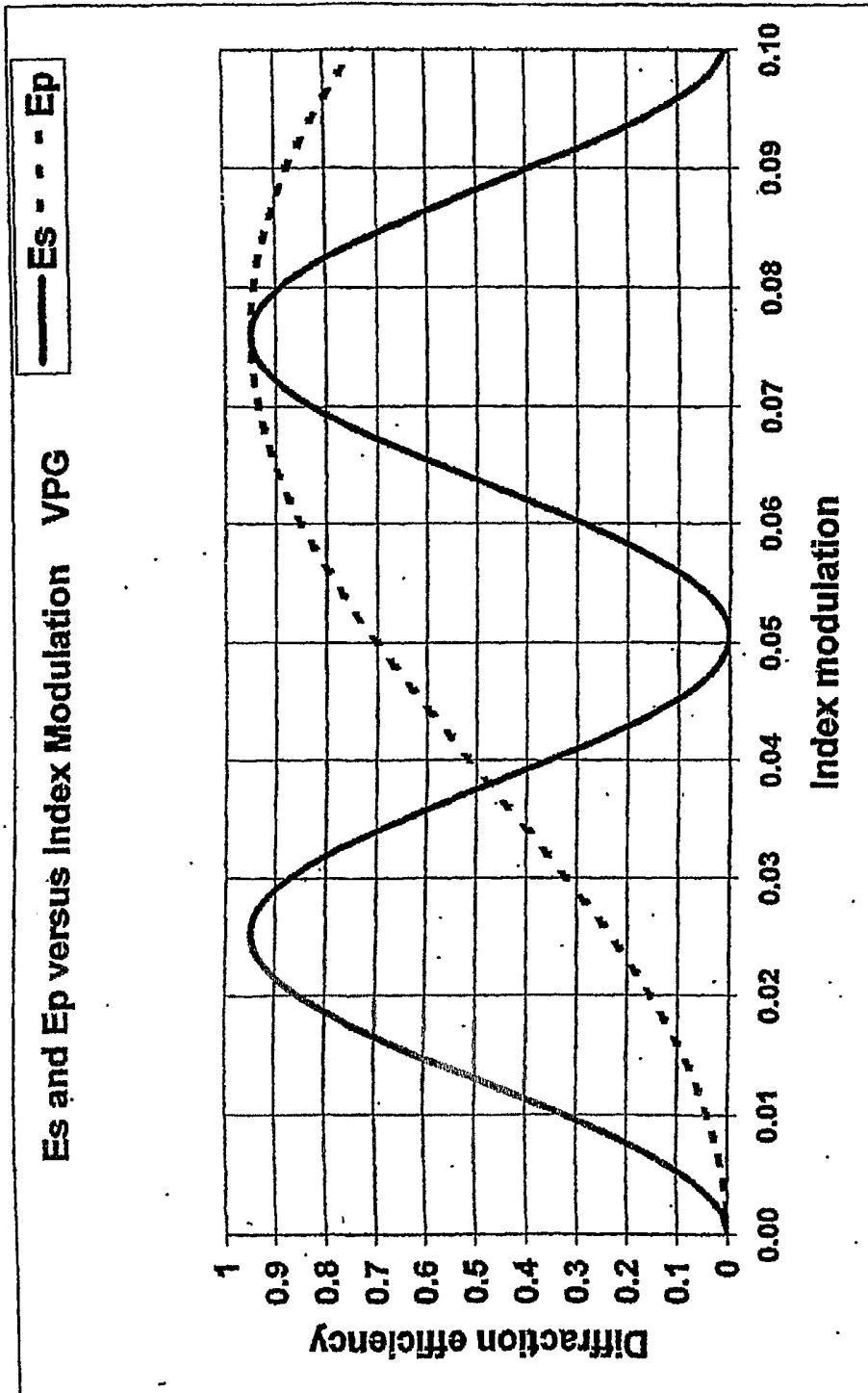

FIG. 10

Sheet 11/20

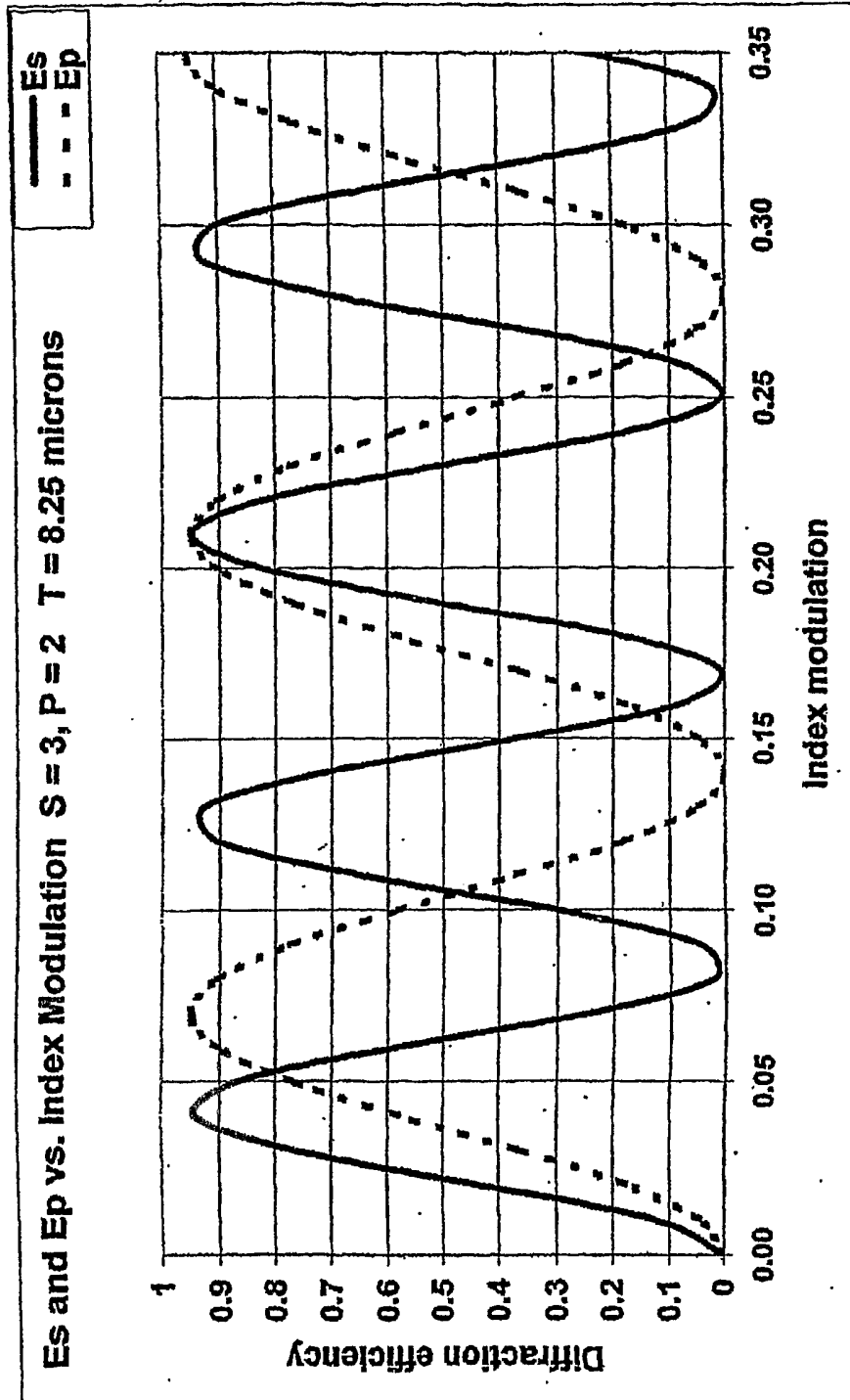

FIG. 11

Sheet 12/ 20

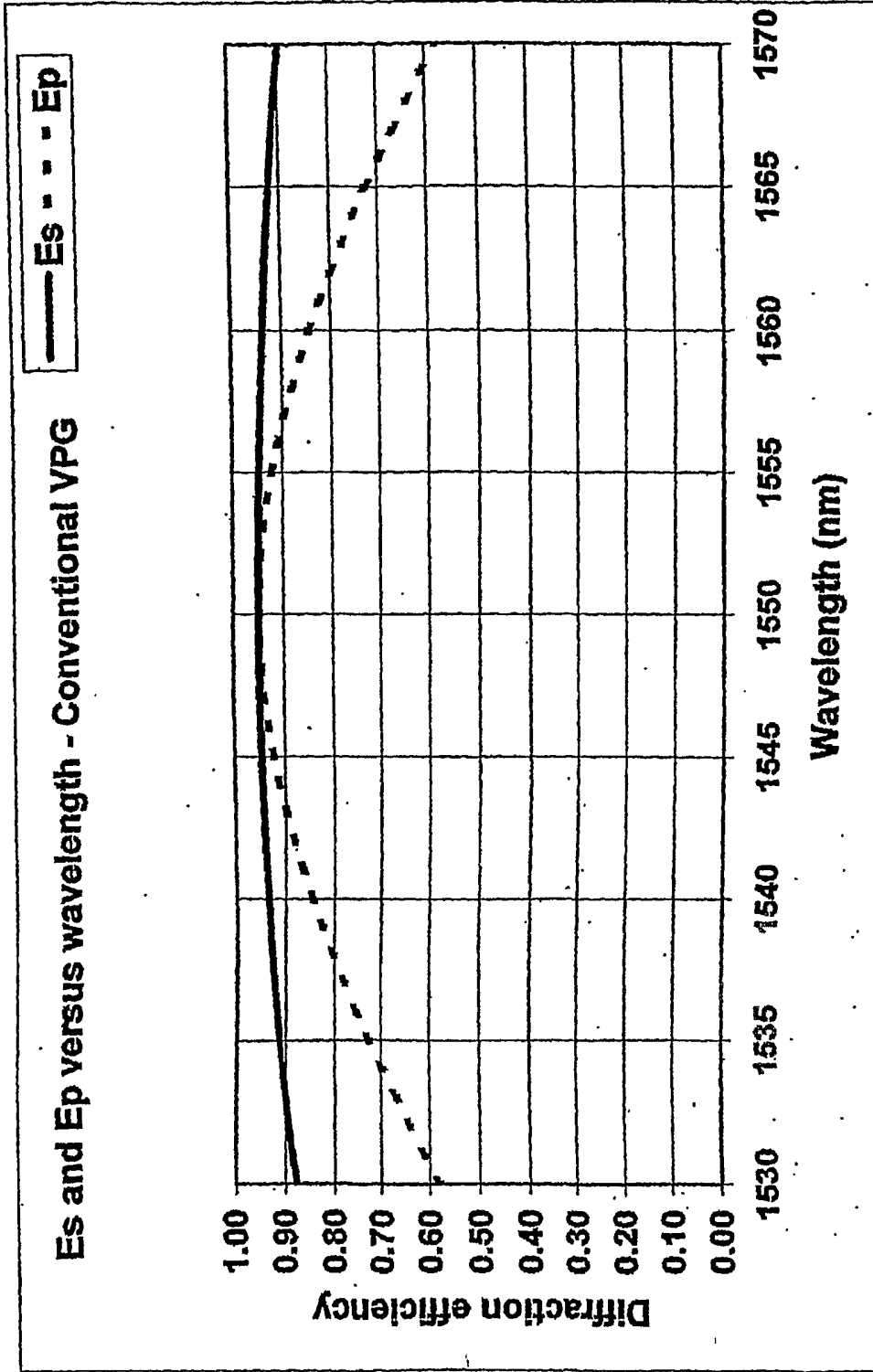

FIG. 12

Sheet 13/20

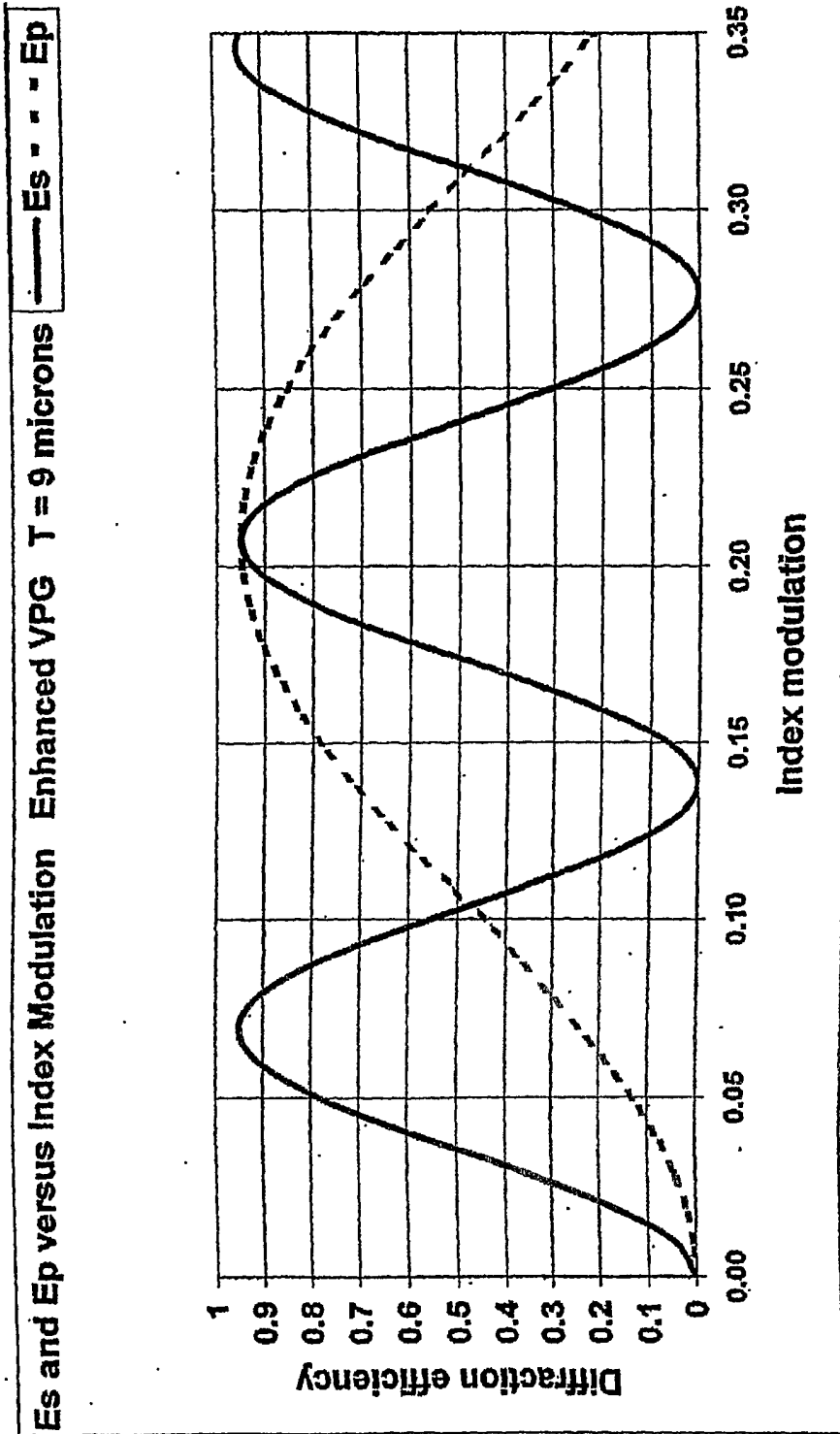

FIG. 13

Sheet 14/ 20

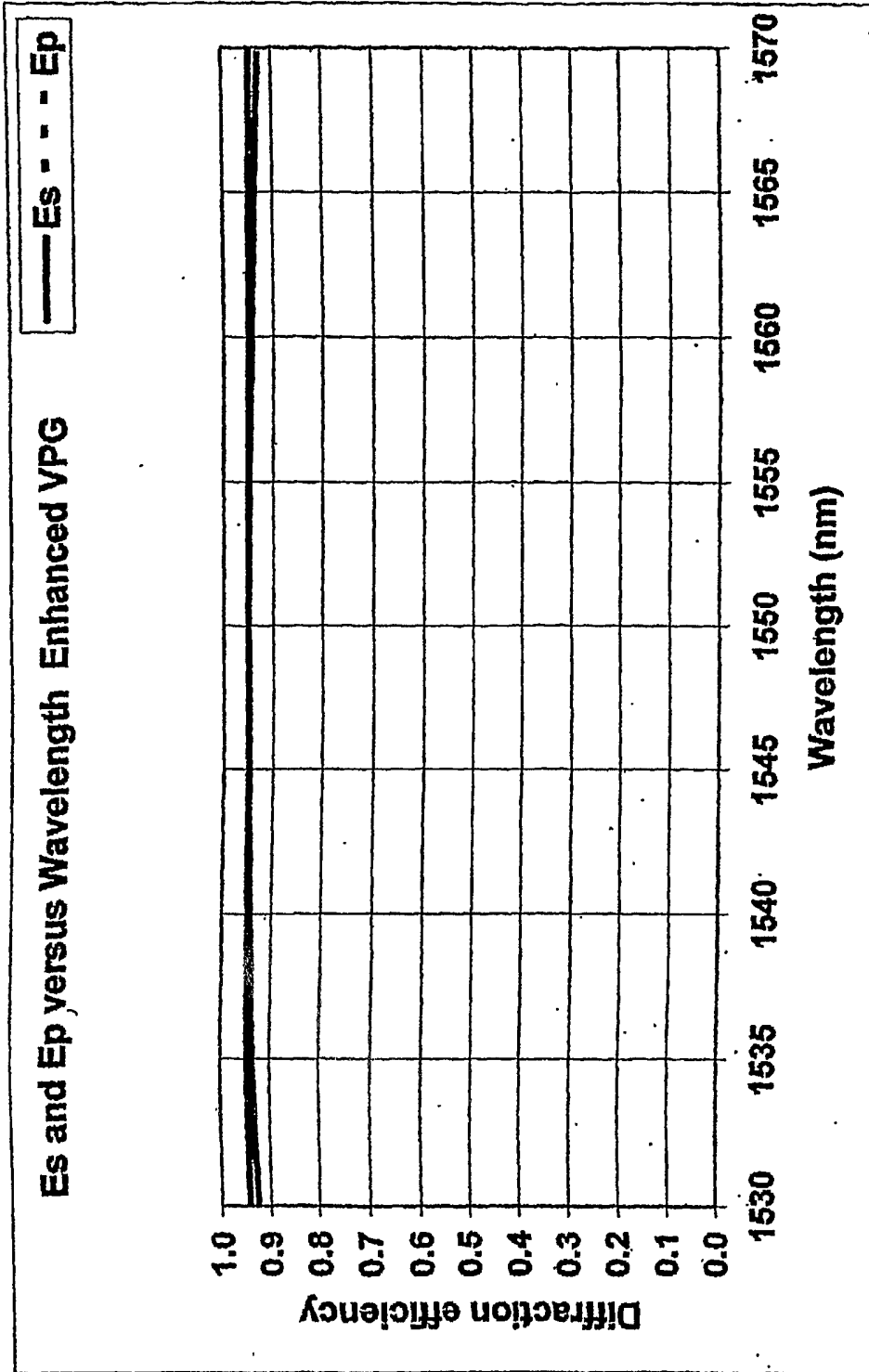

FIG. 14

Sheet 15/20

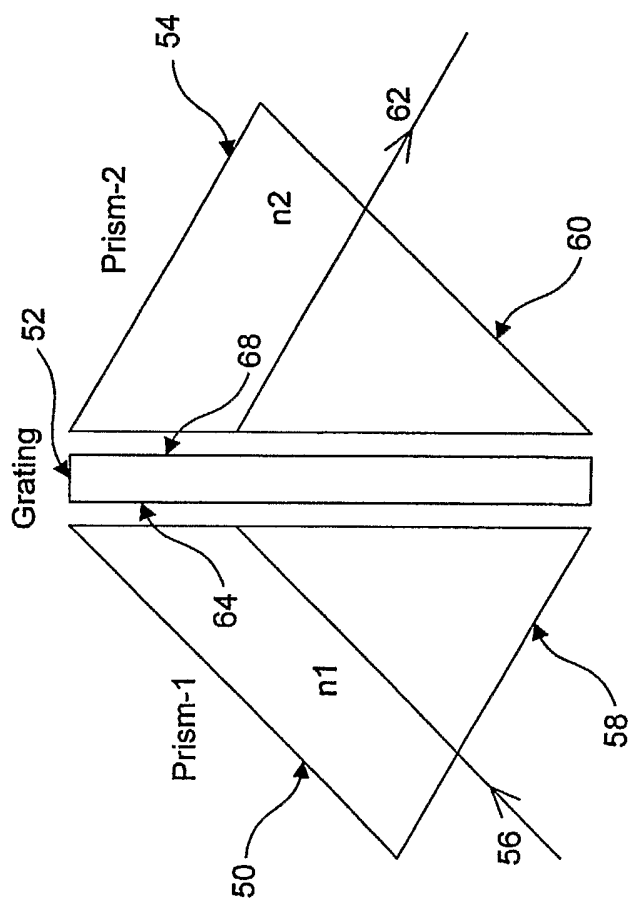

FIG. 15

Sheet 16/20

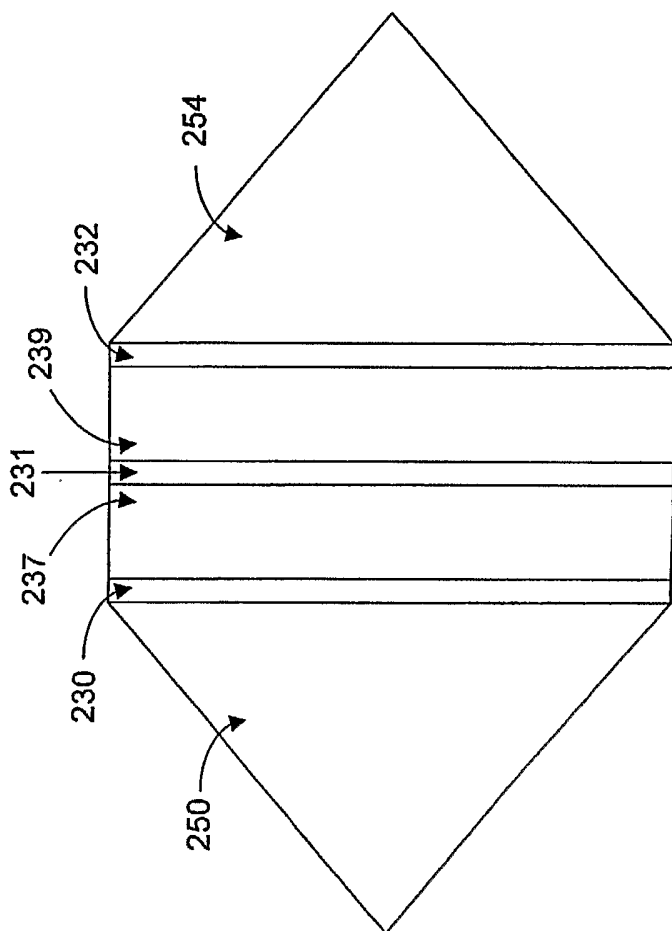

FIG. 15A

Sheet 18/20

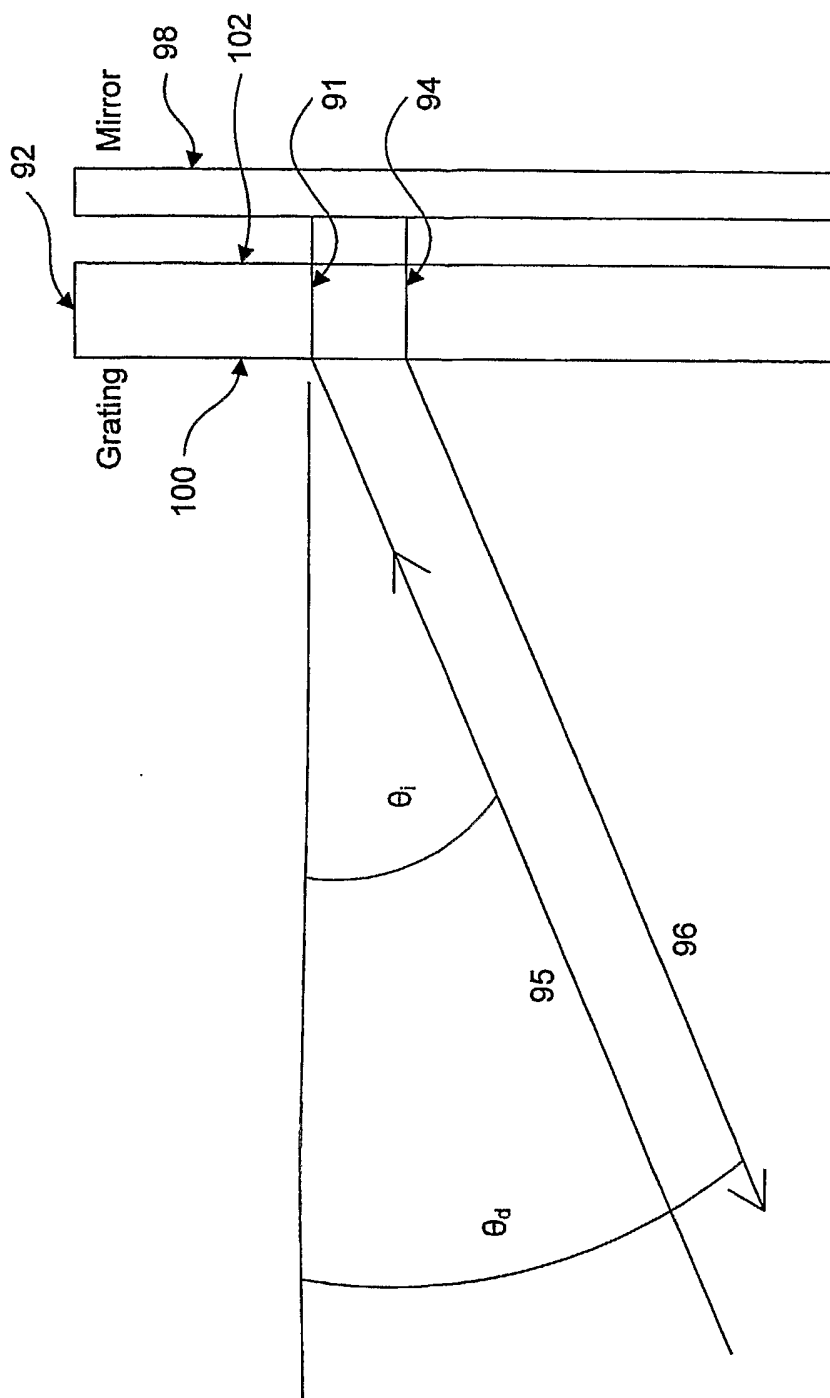

FIG. 17

Sheet 19/20

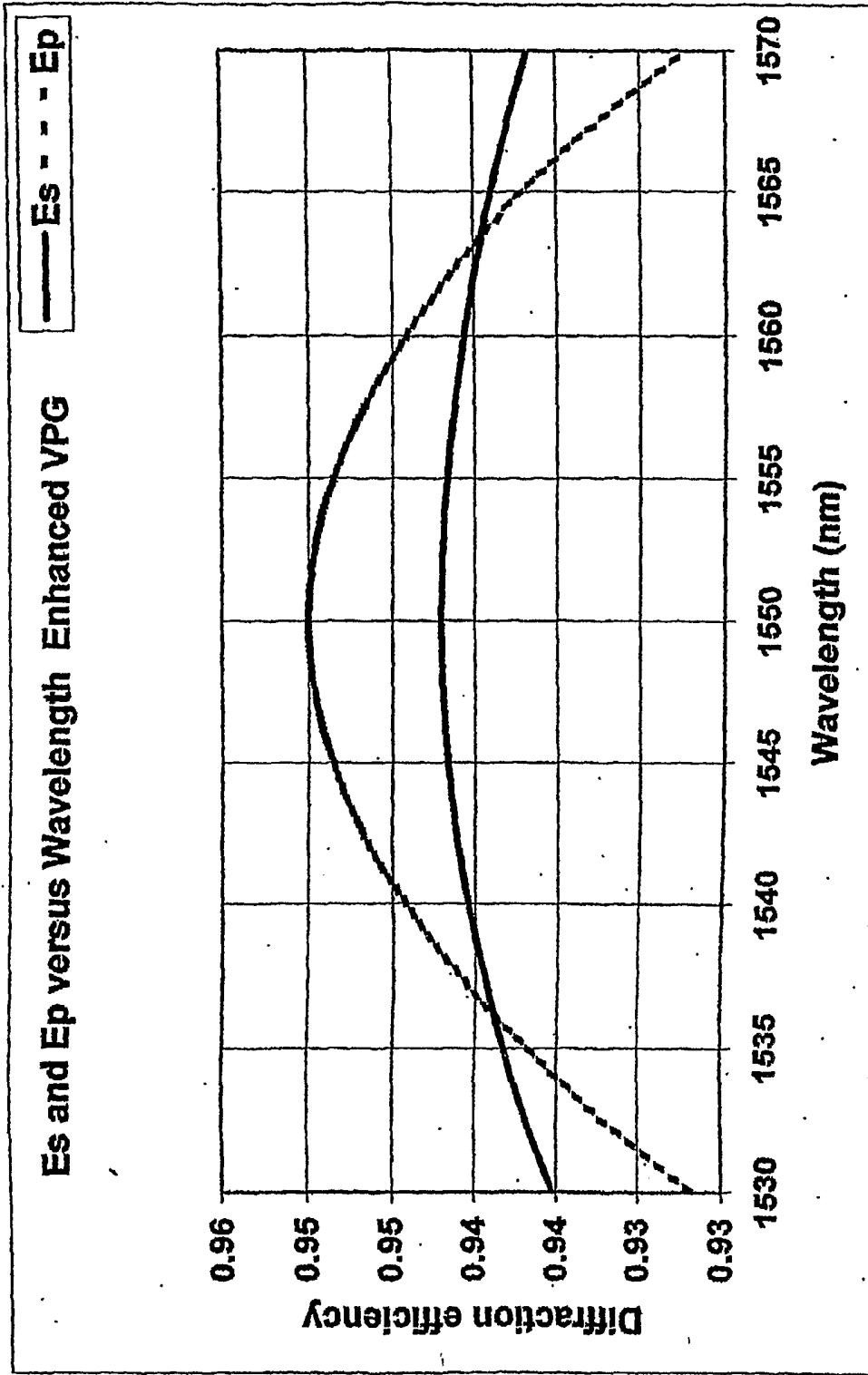

FIG. 18

Sheet 20/20

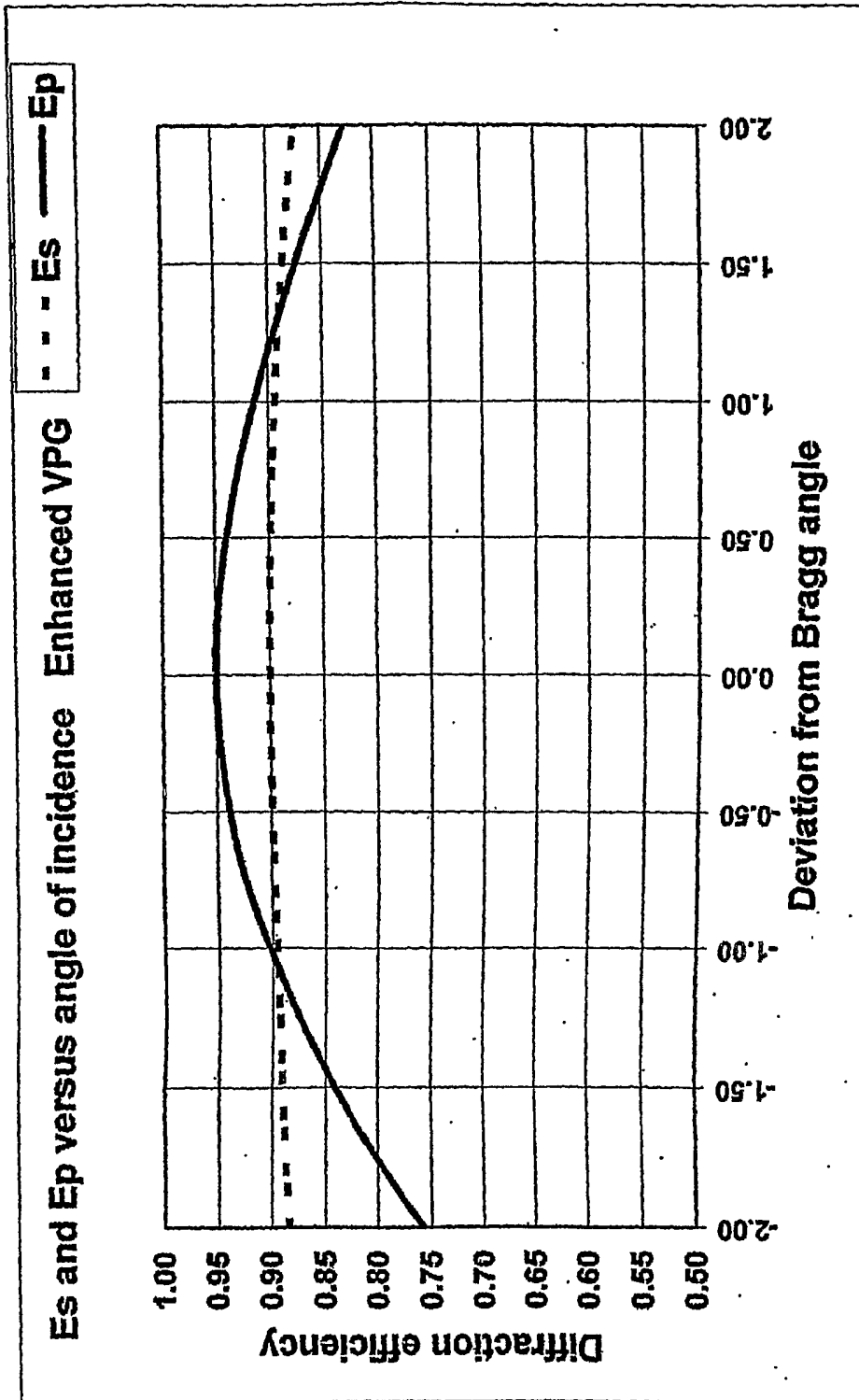

FIG. 19