

(19)
(12)

(KR)
(A)

(51) 。 Int. Cl.7
G08G 1/14

(11)
(43)

10-2004-0021745
2004 03 11

(21) 10-2002-0053063
(22) 2002 09 04

(71) 107-901

(72) 107-901

(74)
:

(54)

가

RFID Tag

3

1 2000-0031655 ;

2 2000-0067195 ;

3 ;

4 ;

5 RFID Tag X, Z

;

6

;

7

;

8

;

9

;

10

RFID Tag

;

11

.

*

*

10: 20:

30: 34:

36: 38:

50: 52:

54: 302:

60: 62: RFID Tag

72: 80:

,

.

가

가

가

2000-0031655

2000-0067195

1

'31655

(500)

(510)

가

(
(Over-Lay)

)

가

가

가

2

'67195
가

가

IC 7-

(가)

가

가

가 가

2

가 7-

7-

()

가

RFID Tag

;

RFID Tag

;

;

;

1

;

;

;

1

;

;

1

2

Z X

1 4

, ; , ; ; 가 ;

1 4

, ;

; ;

; ;

7

가

Tag

7

가

Tag

RFID Tag가

PU 가 Tag Tag RFID Tag C

가

가

가

가

ID

가

RFID Tag (, UHF band, 2.4GHz, 5.8GHz)

(backscattering)

RFID Tag (gantry)

ID ID 가 ;

()

가 (LED Displayer,)

가 (LED displayer)

가

()

(

LED Displayer)

가

) speaker

, Tag가

Tag가

가

Displayer)

(LED

가

ID

tag

가

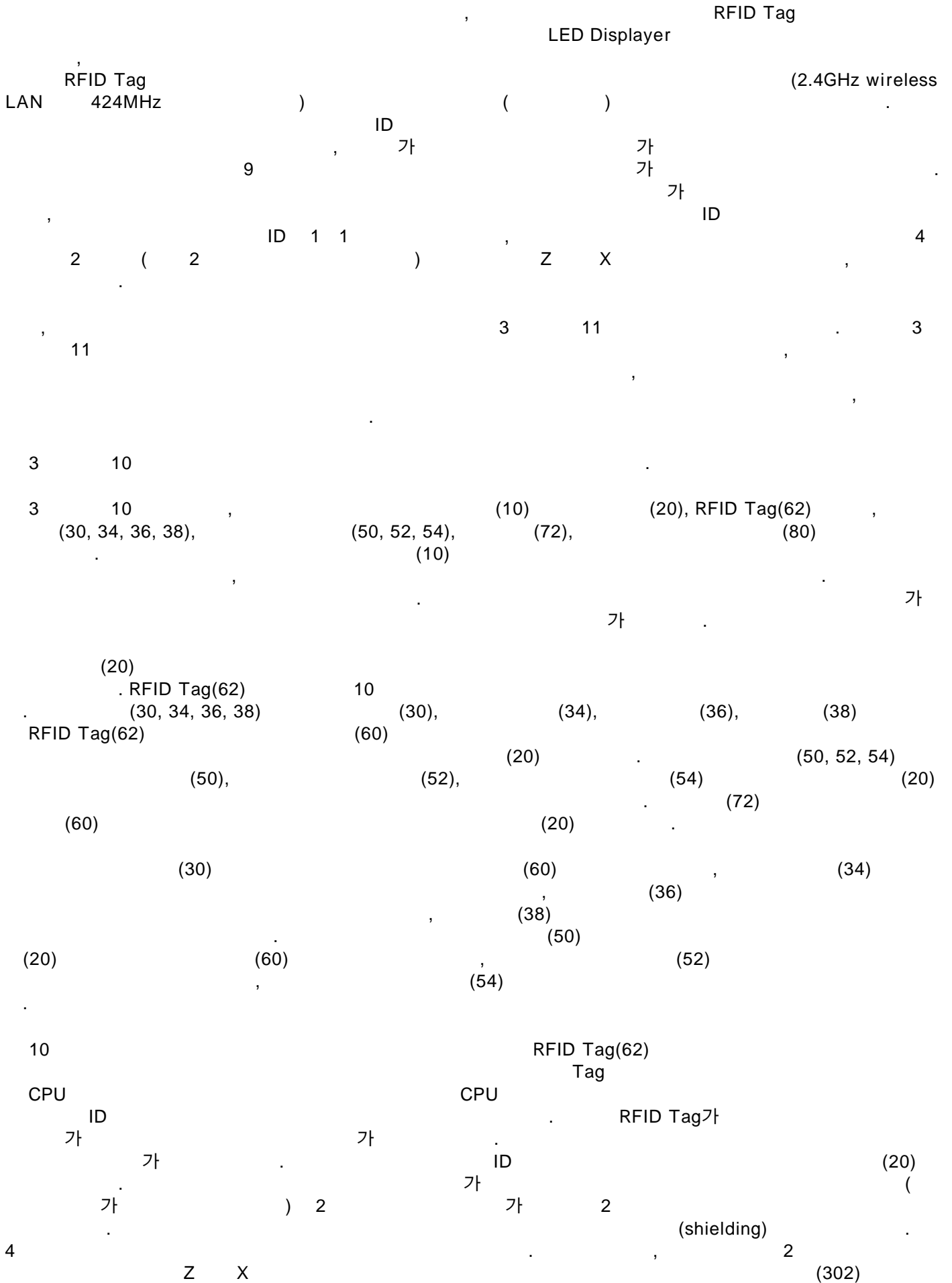

3 RFID Tag(62) Tag가
 RFID Tag(62) LOS(Line Of Sight)가 RFID Tag
 (30) 가 가 RFID Tag(62) IC chip ID
 IC Chip(u-controller) (Backscattering) 가 4
 가 .2 X, Z 2 (2)
 X RFID Tag X,Z 5 (scanning)
 10 RFID Tag Tag TDD()
 Tag가 (downlink) ASK() (polling) Tag (Coding) (uplink) BPSK(2)
 CPU RF MPU, u-controller
 34, 36 2 () (38) (polling) (36) ()
 ID () (52) ()
 가) (36) , 8 (54)
 (20) (72) , (72) 8 (60)
 (64) (70) (72) 가
 (20) 가 (20) ID 가 (80) (80) (20)
 9 (82), (84), (86), (80)
 (90, 92), 가 (88) (80)
) (20) 가 , (80)

(80)

11

11 ,

가 (S140) RFID Tag Tag (gantry) IC chip (S100~S120) Tag

) 7- (S210~S330) ID , , 가 ID (

(,) Tag가 (lane) (S300) (S330). 가

ID가

가 RFID Tag

가 가

11 , (S100). (S110). z 2

(S120). x 가 (S130). 가 .

(S140). ID 가 (3 가 40), ID

(S150) ID 가 (S180, S190). ID (S170)

ID (S200) (S210). (S220). 가

(S230). 가

가 (S240). 가 (S250).

(S280).

(wheel stopper) (S310).

(S320). 가 가 Tag

Z , X (gantry)

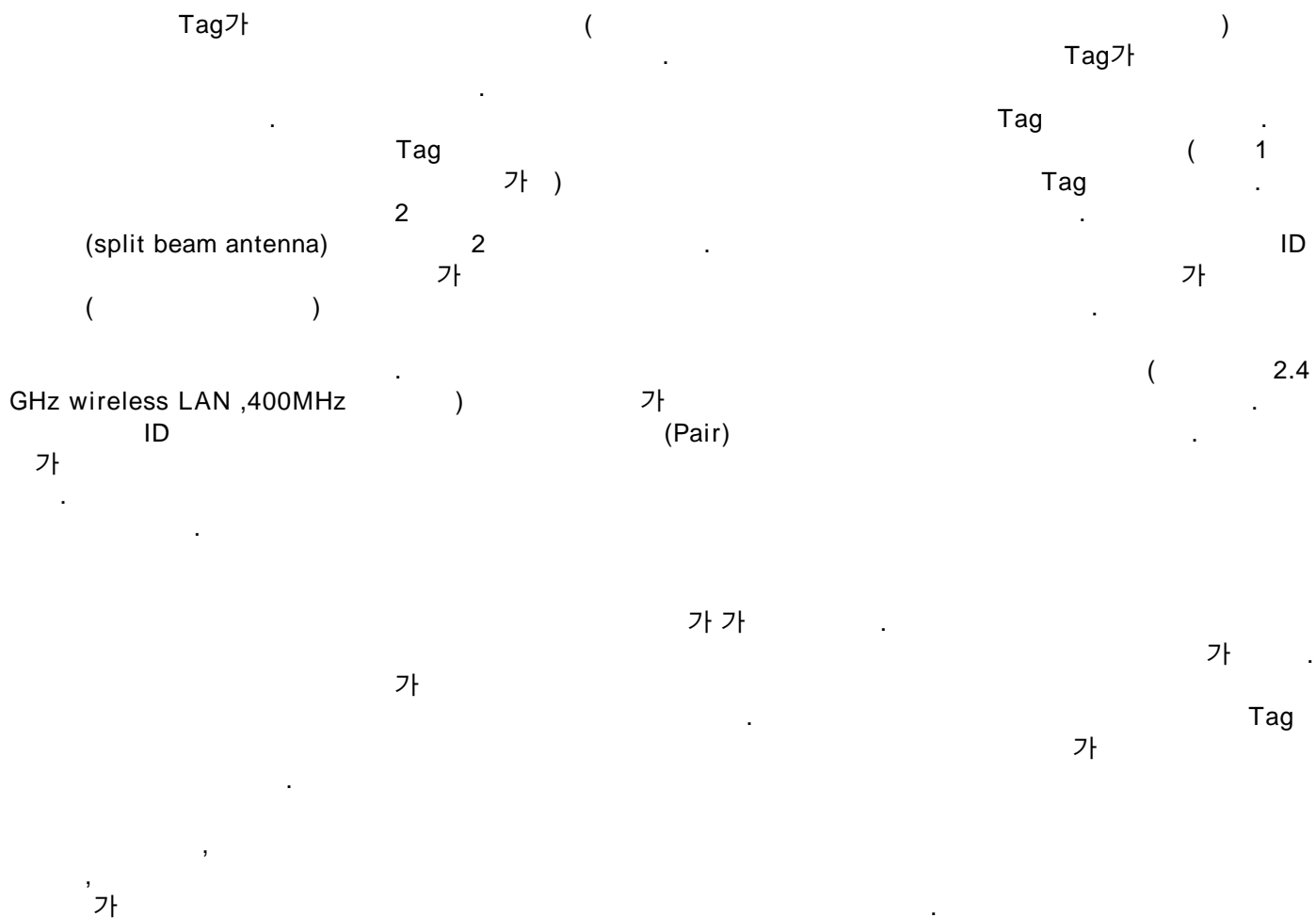

(57)

1.

가 () , ;

RFID Tag ;

RFID Tag ;

1 2.

,

;

;

;

1 3.

,

;

;

2 4.

,

2

Z X

1 5.

4

,

,

;

;

;

,

;

가

1 6.

4

,

7.

,

7 8.

가 가

7 9.

가 Tag RFID Tag가

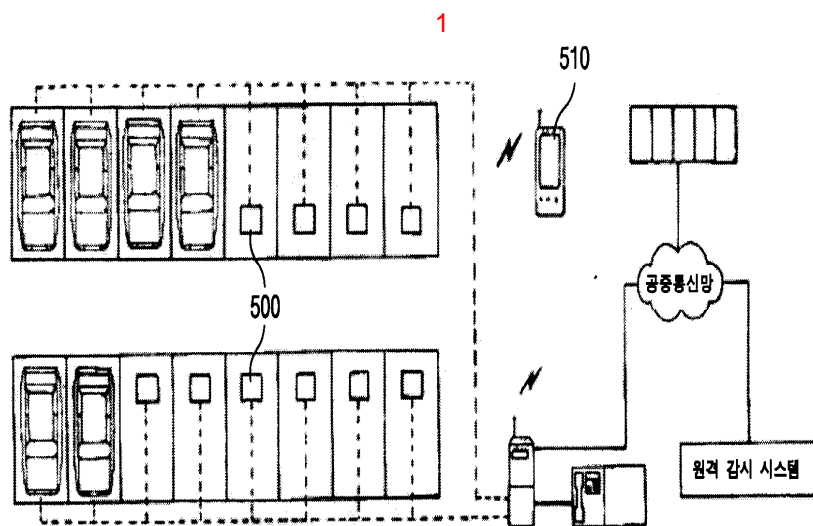

2

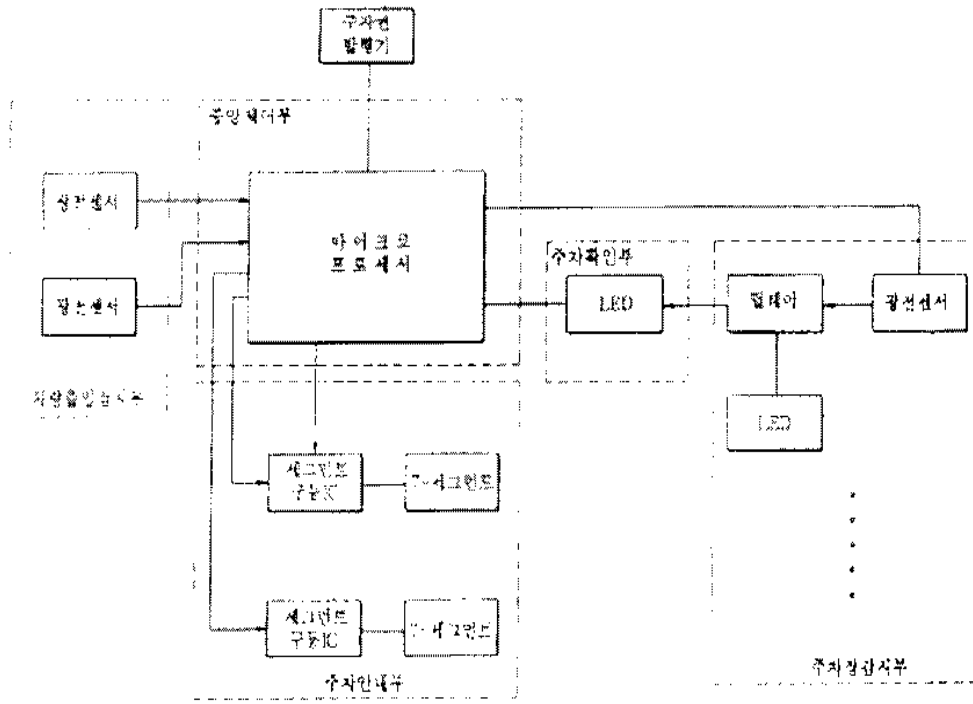

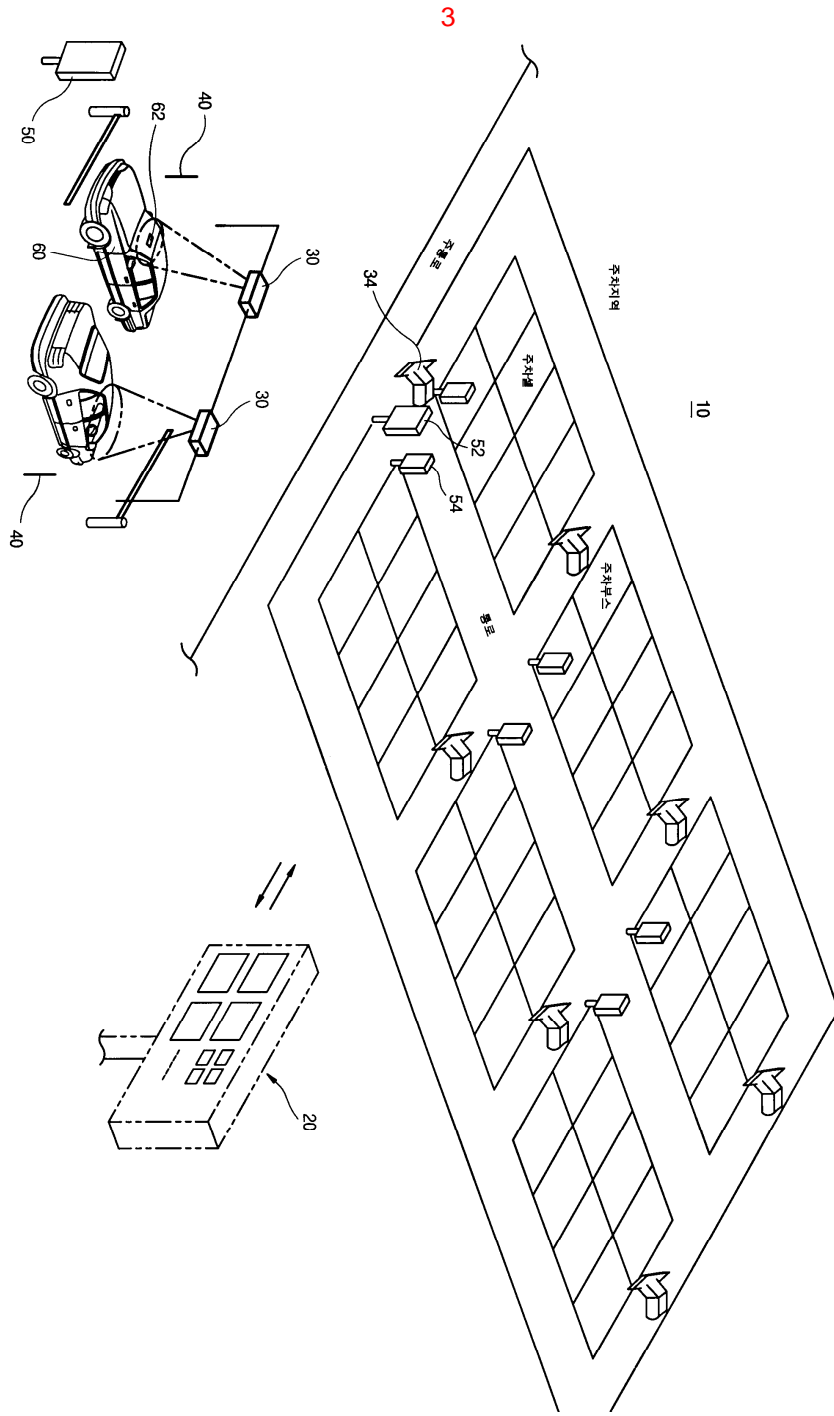

34,36,38

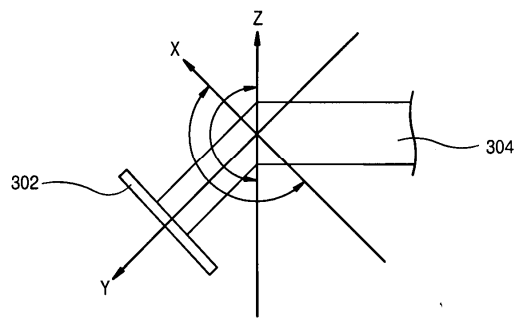

5

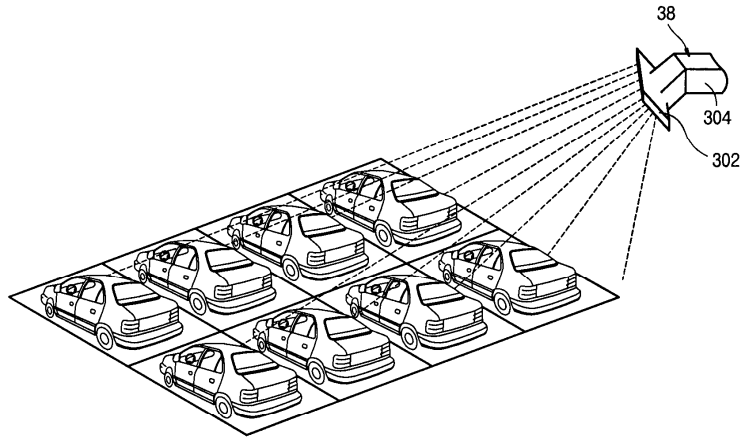

6

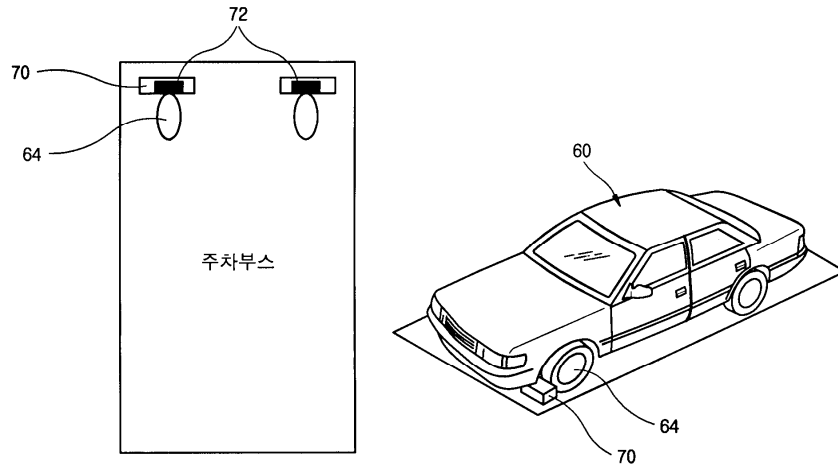

7

52

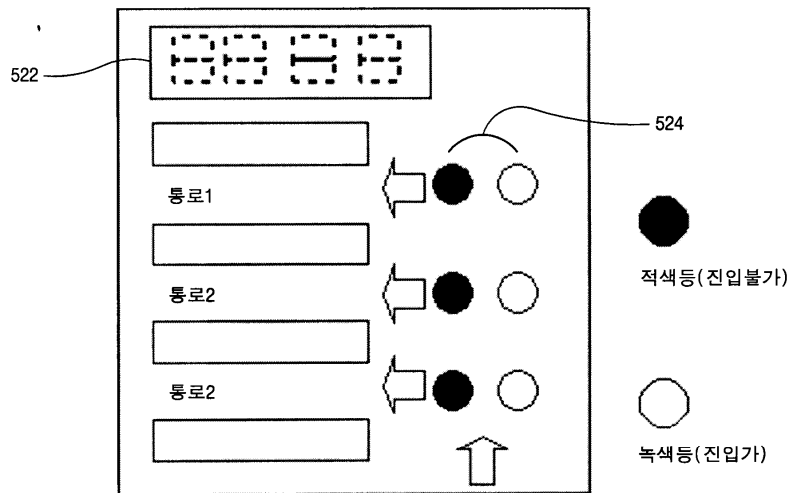

8

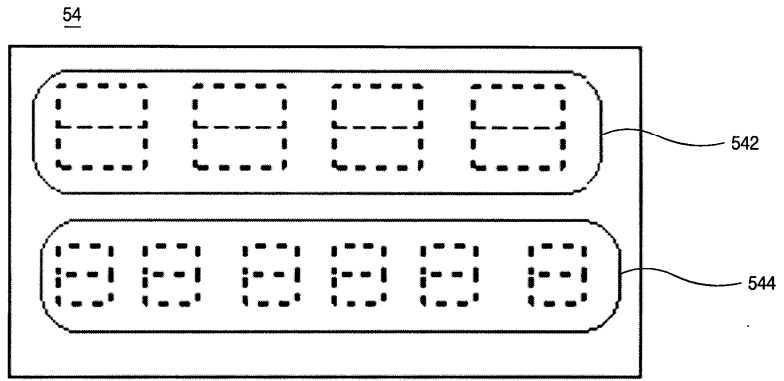

9

