

Feb. 7, 1928.

1,658,095

H. F. PASCHEN

FEEDING DEVICE FOR BELT CONVEYERS

Filed Dec. 14, 1925

3 Sheets-Sheet 1

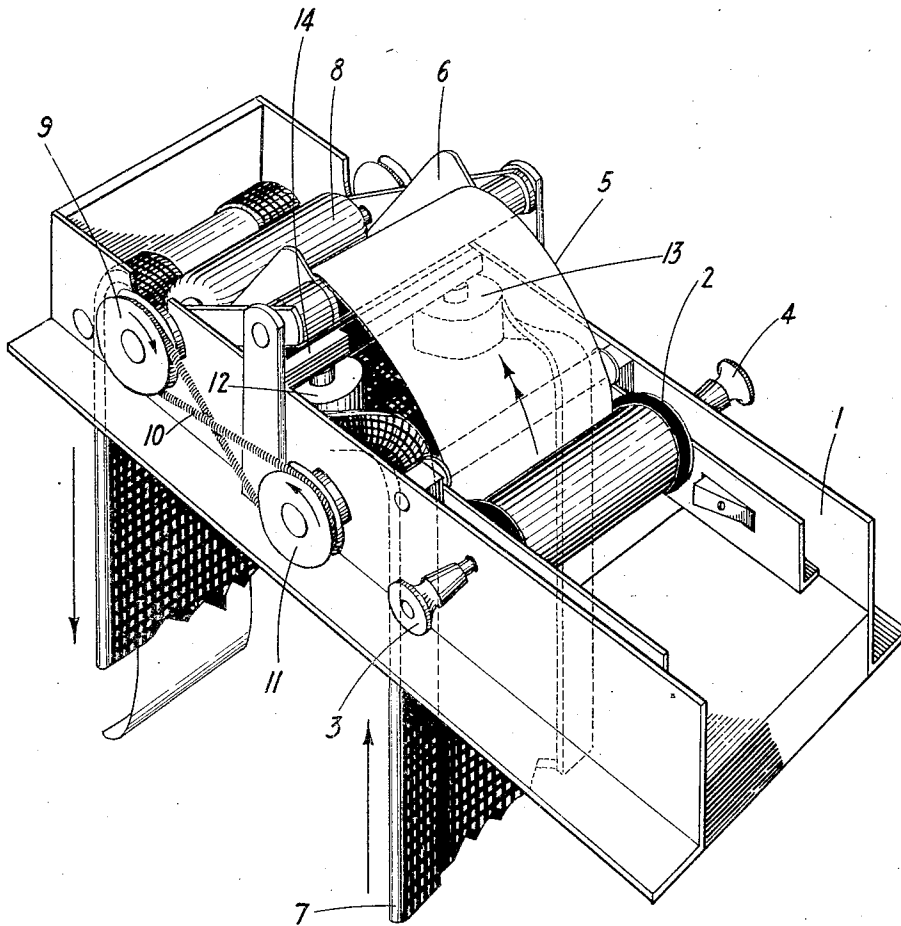

Fig. 1

INVENTOR
H. F. PASCHEN

BY

Geo. F. ...
ATTORNEY

Feb. 7, 1928.

1,658,095

H. F. PASCHEN

FEEDING DEVICE FOR BELT CONVEYERS

Filed Dec. 14, 1925

3 Sheets-Sheet 2

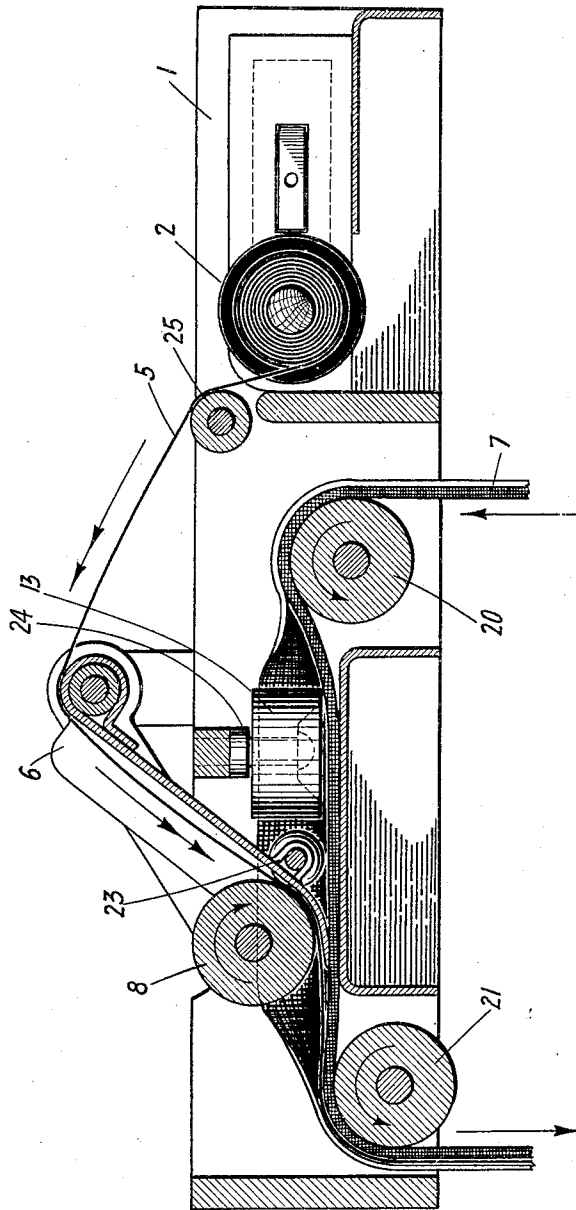

Fig.-2

INVENTOR
H.F.PASCHEN

BY

g. H. H. H.
ATTORNEY

Feb. 7, 1928.

1,658,095

H. F. PASCHEN

FEEDING DEVICE FOR BELT CONVEYERS

Filed Dec. 14, 1925

3 Sheets-Sheet 3

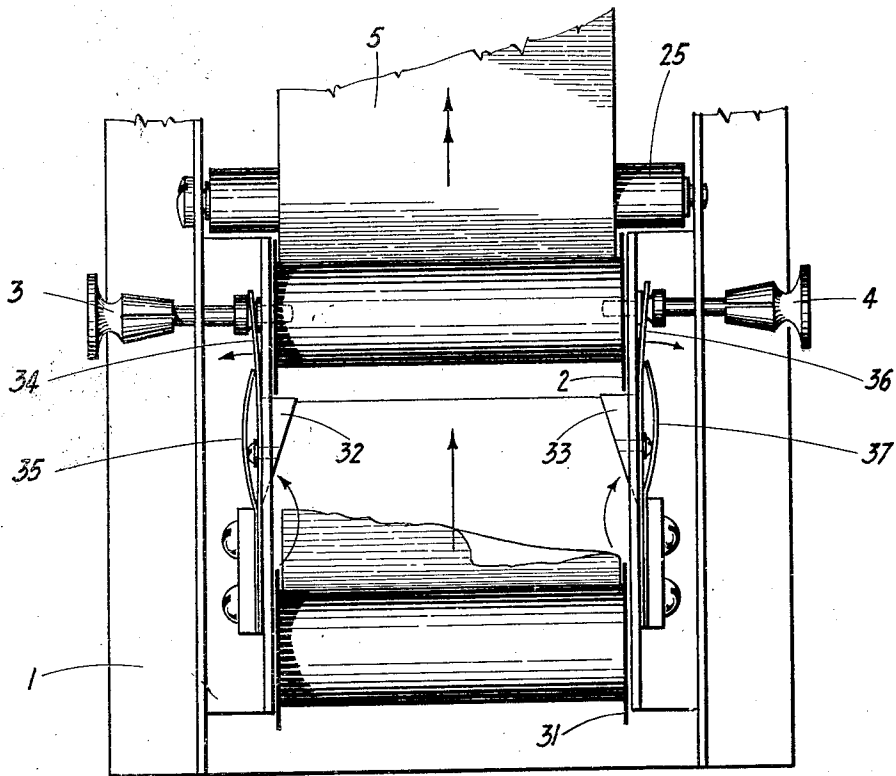

Fig.-3

INVENTOR
H. F. PASCHEN

BY

g. y. m.
ATTORNEY

UNITED STATES PATENT OFFICE.

HAROLD F. PASCHEN, OF NEW YORK, N. Y., ASSIGNOR TO AMERICAN TELEPHONE AND TELEGRAPH COMPANY, A CORPORATION OF NEW YORK.

FEEDING DEVICE FOR BELT CONVEYERS.

Application filed December 14, 1925. Serial No. 75,401.

This invention relates to feeding devices for belt conveyers, and more particularly to arrangements in such devices for feeding paper or other flexible material to a flapped belt, the flaps being employed for gripping the paper or other flexible material to the belt.

A long strip of paper, when conveyed through chemical solutions, becomes wet, and consequently, tends to increase in length. Because of the low tensile strength of the paper it will tear when pulled through such solutions. It is in view of these difficulties that it has been found desirable to provide a flapped belt in a conveying system for conveying paper through chemical solutions, the flaps of the belt being employed for gripping the paper to the belt.

One of the objects of this invention is to provide a suitable device for feeding a long strip of paper to a flapped belt, which device has means associated therewith for spreading the flaps of the belt so that the paper may become flush with the surface of the belt before it is gripped by the flaps of the belt. It is also an object of the invention to provide arrangements for releasing the flaps of the belt after the paper has become flush with the surface of the belt.

While the nature of the invention will be pointed out with particularity in the appended claims, the invention itself, both as to its objects and features, will be better understood from the detailed description hereinafter following when read in connection with the accompanying drawing, in which Figure 1 shows a perspective of one possible feeding device suitable for a flapped belt conveyer; Fig. 2 is a longitudinal cross-section of the device shown in Fig. 1; and Fig. 3 shows one arrangement for supplying a new reel of paper to the feeding device after the old one has been completely unwound. Similar parts will be designated by similar reference characters wherever they appear throughout the drawing.

One type of feeding device for a flapped belt conveyer is shown at Fig. 1. The base of this feeding device is designated by the reference character 1. A rotatable reel 2, which has a long strip of paper or other flexible material wound thereon, is held between the end-bearing holders 3 and 4. The strip of paper 5 is unwound from the rotat-

able reel 2 in the direction indicated by the double pointed arrow. This strip of paper 5 passes over a horizontal rotatable roller (not shown), and then moves down a slide 6, which has end projections to guide the paper 5 unwound by the rotatable reel to the movable flapped belt 7. The movable flapped belt moves in the direction indicated by the single pointed straight line arrows, and after the paper has come in contact with the movable belt, the flaps of the belt are released for gripping the paper thereto as will appear more fully in the description hereinafter following. The movable belt with the paper held thereon is shown at the left-hand side of the drawing.

A horizontal rotatable roller 8 is employed for aiding in pulling the paper 5 unwound by the rotatable reel 2 to the movable belt. A pulley 9 is on the same shaft as the horizontal rotatable roller 8 and has a belt 10 thereon. The belt 10 connects the pulley 9 with another pulley 11, which may be similar in all respects to pulley 9. Pulley 11 is on the same shaft as a horizontal rotatable roller over which the movable belt 7 moves. The belt 10 is crossed so that pulleys 9 and 11 and, consequently, the horizontal rotatable rollers on the same shafts as these pulleys, respectively, revolve in opposite directions as indicated by the arrows on these pulleys.

In this device there is shown one arrangement for spreading the flaps of the movable belt 7 so that the paper 5, unwound from the rotatable reel 2, may come in contact with the movable belt 7 before the flaps release to grip the paper. For accomplishing this there are two vertical rotatable rollers, 12 and 13, which are suspended by vertical bearings in a bearing-holder 14, the details of which will be shown and described in connection with Fig. 2. The lower surfaces of the vertical rotatable rollers 12 and 13 are very close to the surface of the belt, and they revolve in such a manner that the flaps of the movable belt 7 are spread apart. It is due to these vertical rotatable rollers 12 and 13 that the flaps are sufficiently spread apart so that the paper 5, unwound from the rotatable reel 2, may come in contact with the surface of the movable belt 7. However, after the paper has come in contact with the movable belt 7 the flaps are re-

leased so as to grip the paper firmly to the movable belt. It will be understood that while two vertical rotatable rollers have been shown for spreading the flaps of the belt, that they may be replaced by a single vertical rotatable roller of suitable diameter for accomplishing the same end.

Fig. 2 shows a longitudinal cross-section of the particular feeding device shown in Fig. 1. The rotatable reel 2 is unwound so that the paper 5 may move over a slide 6, which is guided by the end projections thereof to the movable belt 7. The double-pointed straight-line arrows indicate the direction in which the paper 5 moves. The belt moves over the horizontal rotatable rollers 20 and 21 in the direction indicated by the arrows on these rollers. The paper 5 moves between two horizontal rotatable rollers 8 and 23, to the movable belt 7. The peripheral speeds of the horizontal rollers 8 and 20 must of course be equal.

One of the vertical rotatable rollers 13 with its associated vertical suspension bearing 24 is shown in this figure. One flap of the belt is moved up against the surface of the vertical rotatable roller 13 a sufficient distance so as to allow the paper 5 to come in contact with the movable belt 7. After the paper 5 has come in contact with the movable belt there may be means associated with the device for releasing the flaps of the belt so as to allow the flaps to firmly grip the paper; but by the use of flaps which are elastic and which tend to return to their initial positions, such additional means may not be deemed necessary. After the paper 5 has been unwound from the rotatable reel 2, the reel drops of its own weight through a hole in the base 1, as will be shown more fully hereinafter.

Fig. 3 shows arrangements for replacing a reel after the paper thereon has been completely unwound. In this figure the rotatable reel 2 is held in place between end bearings which are fastened in bearing-holders 3 and 4, respectively. The paper 5 moves over the horizontal rotatable roller 25 to the slide in the direction indicated by the double-pointed arrow. After the paper 5 has been completely unwound from the rotatable reel 2, a new reel 31, must then be moved into place. This new reel 31 is moved against two projections 32 and 33, which move outwardly when the new rotatable reel 31 is about to be put in place between the bearings in the bearing-holders 3 and 4. Four springs, 34, 35, 36 and 37, are associated with the projections 32 and 33, two of these, 34 and 35, being associated with the projection 32, and the other two, 36 and 37, being associated with the projection 33. As the projections 32 and 33 move outwardly the springs 34 and 35, 36 and 37, move outwardly and, because of the con-

nection of the springs 34 and 36 with the bearing-holders 3 and 4, respectively, these bearing-holders 3 and 4 and the end bearings held thereby, are also moved outwardly. The projections 32 and 33 are so proportioned that the new reel 31, when almost in position, causes the end bearings to be moved outwardly a sufficient distance so that the rotatable reel 2 may drop through a hole in the base 1. After the reel 2 has dropped, the new reel 31, having the paper wound thereon, moves into place, and the projections 32 and 33 move inwardly to their initial positions so that the end bearings, held in the bearing-holders 3 and 4, project into a hole in the center of the rotatable reel 31. The springs 34 to 37 may be made of phosphor bronze or other springy material.

It will be understood that while only one type of a feeding device for a belt conveyer has been shown and described herein in connection with this invention, the invention is not limited to the particular type of device shown and described, but the invention may be embodied in other and widely varied organizations without departing from the spirit of the invention and the scope of the appended claims.

What is claimed is:

1. In a device for feeding paper to a movable flapped belt, in combination, a rotatable reel adapted to hold a roll of paper, a stationary holder for said rotatable reel, a movable belt flapped at the edges, a pair of rotatable rollers for spreading the flaps of the movable belt to allow the paper unrolled from the reel to engage the movable belt, and means for returning the flaps of the movable belt to their overlapped condition after the paper has engaged the movable belt.

2. In a device for feeding paper to a movable flapped belt, in combination, a movable flapped belt, a rotatable reel adapted to hold a roll of paper, means for spreading the flaps of the movable belt to allow the surface of the paper unwound from the rotatable reel to come in contact with the surface of the movable belt, and means for returning the flaps of the movable belt to their overlapped condition after the surface of the paper unwound from the rotatable reel has come in contact with the surface of the movable belt.

3. In a device for feeding paper to a movable belt, in combination, a movable flapped belt, a rotatable reel adapted to hold a roll of paper, means for spreading the flaps of the movable belt to allow the surface of the paper unwound by the rotatable reel to come in contact with the surface of the movable belt, means for guiding the paper unwound by the rotatable reel to the movable belt, and means for returning the flaps of

the movable belt to their overlapped condition after the surface of the paper has come in contact with the movable belt.

4. In a device for feeding material such as paper to a movable flapped belt, in combination, a movable flapped belt, a rotatable reel adapted to have wound thereon the material to be fed to the movable belt, and a vertical rotatable roller having its axis of rotation perpendicular to the path of the movable belt for spreading the flaps of the movable belt to allow the surface of the material unwound by the rotatable reel to be fed to the movable belt to come in contact with the surface of said movable belt, the flaps of the movable belt being elastic and releasing to grip the material unwound by the rotatable reel after the surface of the unwound material has come in contact with the surface of the movable belt.

5. In a device for feeding flexible material to a movable flapped belt, in combination, a movable flapped belt, a rotatable reel adapted to hold a roll of flexible material to be fed to the movable belt, a pair of vertical rotatable rollers each having its axis of rotation perpendicular to the path of the movable belt, the vertical rotatable rollers being employed for spreading the flaps of the movable belt to allow the surface of the flexible material unwound by the rotatable reel to come directly in contact with the surface of the movable belt, and means for returning the flaps of the movable belt to their overlapped condition to grip the material unwound by the rotatable reel after the surface of the material has come in contact with the surface of the movable belt.

6. In a device for feeding flexible material such as paper to a movable belt, in combination, a movable belt having its edges bent over to form flaps, a rotatable reel adapted to have wound thereon a roll of flexible material such as paper to be fed to the movable belt as it is unwound by the rotatable reel, and a pair of vertical rotatable

rollers each having its axis of rotation perpendicular to the path of the movable belt, the vertical rotatable rollers being employed for spreading the flaps of the movable belt to allow the flexible material unwound by the reel to come flush with the surface of the movable belt, the flaps thereafter being released to firmly grip the flexible material to the movable belt.

7. In a feeding device for a belt conveyer, in combination, a movable belt having flapped edges, a rotatable reel adapted to have wound thereon a roll of paper, a pair of vertical rotatable rollers each having its axis of rotation perpendicular to the path of the movable belt, each of said vertical rotatable rollers being moved against a flap of the movable belt for spreading the flap, means for guiding the paper unwound by the rotatable reel to that part of the belt at which the flaps are spread, and means for returning the flaps of the movable belt to their overlapped condition so as to grip the paper unwound by the rotatable reel.

8. In a feeding device for a belt conveyer, a movable flapped belt, a rotatable reel adapted to have a long strip of paper wound thereon to be fed to the movable flapped belt, a horizontal rotatable roller having its axis of rotation parallel to the movable flapped belt and rotated thereby, the strip of paper unwound by the rotatable reel being moved between said horizontal rotatable roller and the movable belt, and two vertical rotatable rollers each having its axis of rotation perpendicular to the movable belt, each of said latter rollers functioning to spread the flaps of the movable belt to allow the paper unwound by the rotatable reel to come in contact with the surface of the movable belt.

In testimony whereof, I have signed my name to this specification this 12th day of December 1925.

HAROLD F. PASCHEN.