

June 13, 1967

P. E. HANSER

3,324,582

EARTH SCRAPER

Filed July 2, 1964

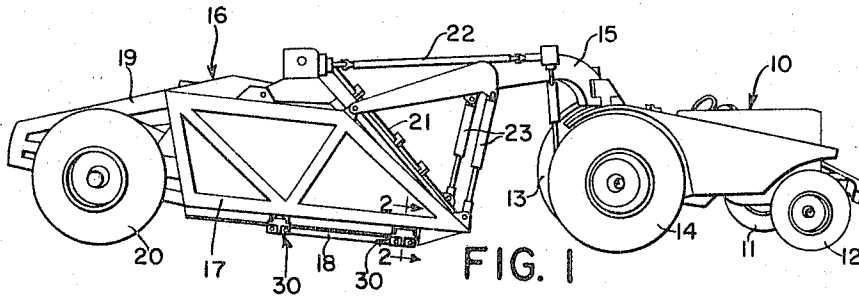

FIG. 1

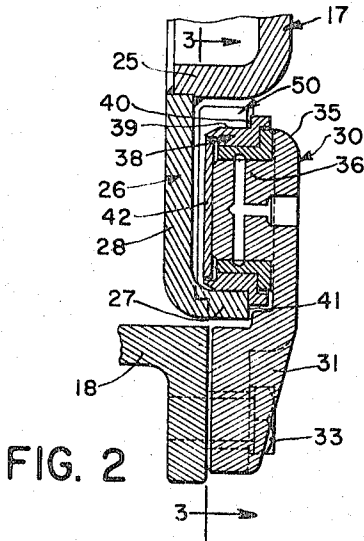

FIG. 2

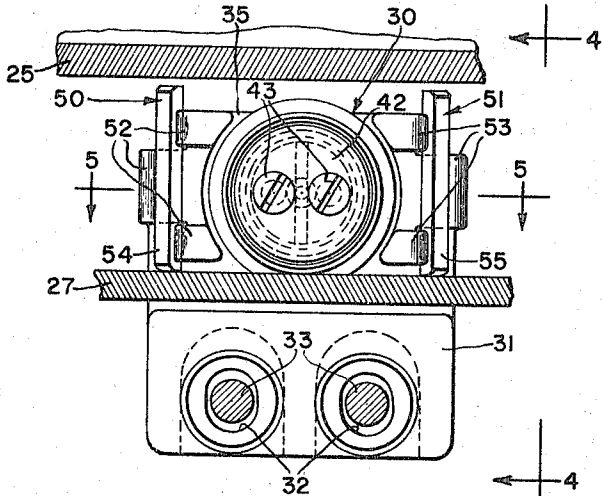

FIG. 3

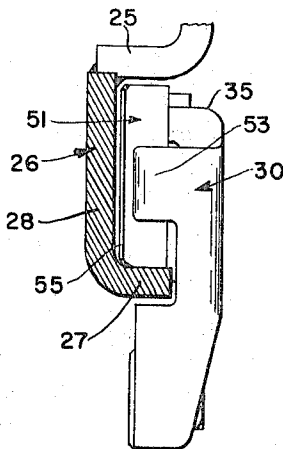

FIG. 4

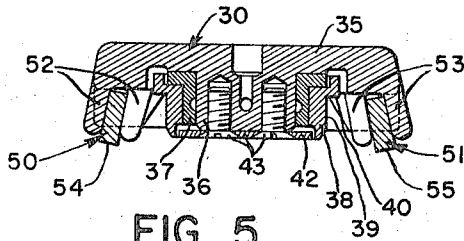

FIG. 5

INVENTOR  
P. E. HANSER

BY *William A. Murray*  
ATTORNEY

1

3,324,582

**EARTH SCRAPER**

Paul E. Hanser, Rock Island, Ill., assignor to Deere & Company, Moline, Ill., a corporation of Delaware  
 Filed July 2, 1964, Ser. No. 379,870  
 8 Claims. (Cl. 37-129)

This invention relates to an earth scraper and more particularly to the type of earth scraper having a material carrying bowl composed of a pair of upright side walls interconnected at their lower edges by a floor structure, part of which is retractable for purposes of unloading material from the bowl. Still more particularly this invention relates to the supporting structure between the sides of the bowl and the retractable floor part.

The retractable floor part has normally been supported by hanger members engaging tracks on the bowl sides so that the retractable floor part may slide longitudinally in respect to the lower edges of the sides. The hanger members are normally supported on the tracks by a series of rollers that roll along the tracks. Conventionally such tracks and rollers are closely adjacent the ground. One of the primary problems created with the simple roller and track arrangement for moving the floor longitudinally occurs due to dirt and other material normally gathering in the track. The rollers will tend to harden and compress this material by the simple process of rolling over it. Consequently in many instances there will be a large buildup of material formed in hard crusts on the track. Eventually this crust may buildup to such an extent that dirt is forced into the bearings supporting the rollers and eventually the entire supporting hanger mechanism will fail.

With the above in mind, it is the primary object of the present invention to provide a new and novel type of supporting roller and hanger arrangement for carrying the floor along the underside of the scraper bowl. The arrangement includes outwardly opening U-shaped tracks with upper and lower horizontal flanges and a roller riding on the lower of the flanges and having a radial shoulder bearing against the edge of a lower flange so as to resist axial thrust on the roller. The roller is normally smaller than the spacing between the upper and lower flanges. It is proposed to provide a pair of scraper blades in advance of and behind respectively the roller operating to clean the material from the tracks as the floor is moved. The scraper blades are supported on the hanger structure for free vertical movement. The blades have a greater height than the diameter of the roller but are smaller in height than the spacing between the upper and lower flanges. The scraper blades are angled so that as the roller advances over the track, the lower edge of the scraper blade will contact material and drive it both outwardly and in a trailing direction in respect to the direction of movement of the roller.

Other advantages of the present invention will become apparent to those skilled in the art as the nature of the invention is better understood from the following description and as shown on the accompanying drawings.

FIG. 1 is a side perspective view of a tractor and scraper implement utilizing the features of the present invention.

FIG. 2 is a sectional view taken substantially along the lines 2-2 of FIG. 1.

FIG. 3 is a sectional view taken substantially along the line 3-3 of FIG. 2.

FIG. 4 is a sectional view taken substantially along the line 4-4 of FIG. 3.

FIG. 5 is a sectional view taken substantially along the line 5-5 of FIG. 3.

2

The assembly is composed of a tractor 10 having front steerable wheels 11, 12 and rear traction wheels 13, 14. A yoke structure 15 extends rearwardly from the tractor 10 and is connected to a bowl 16 having opposed and transversely opposite upright sides 17 interconnected at their lower edges by floor structure, a part 18 of which may be moved longitudinally in respect to the lower edges of the walls 17. The bowl 16 is further supported on rear carrying wheels 20, a suitable framework 19 extending between the wheels 20 and the bowl 16. Disposed in the forward open side of the bowl 16 is an elevator 21 driven by a drive 22 suitably connected to a power take-off shaft on the tractor. The forward end of the bowl 16 may be raised and lowered by suitable adjustment of hydraulic cylinders 23. Other than the details herein to be described, the scraper and its tractor 10 is described generally and only sufficiently for purposes of clearly understanding the present invention. Details of the scraper, drive 22, and elevator 21 are shown and described in U.S. Patents 3,028,694; 3,038,266; and 3,048,933. If further details are desired, such may be had by referring to those patents.

The floor part 18 is supported by front and rear supporting assemblies on opposite sides of the floor part 18. The supporting assemblies are identical and consequently detailed description of only the supporting assembly at the front right-hand side is given in the particular instance. The side walls 17, have at their lower edges a horizontal fore-and-aft extending beam with a lower horizontal flange 25 that turns inwardly from the wall 17. Welded to the inner end of the flange 25 is an L-shaped track member 26 having a lower outwardly extending horizontal flange 27 and an upright web or flange 28. The entire track structure is therefore defined at its lower side by the flange 27, at its upper side by the flange 25, and at its inner side by the upright web 28. As may be seen clearly from viewing FIGS. 1 and 2, the track structure on the right-hand side of the implement opens outwardly. A similar outwardly opening track structure is provided on the left side of the implement.

A hanger member 30 is disposed outwardly of the track 26 and has a lower portion 31 opposite the outer edge of the floor 18. The lower portion 31 is provided with suitable openings 32 for receiving bolts connecting the lower portion 31 rigidly with the edge of the movable floor part 18. An upper portion 35 of the hanger 30 is disposed opposite the open side of the track structure and has an inwardly projecting boss 36 receiving a bushing 37. The boss 36 is disposed within the spacing defined by the upper flange 25 and the lower flange 27. Carried on the bushing 37 is a roller 38 having its main peripheral portion 39 adapted to ride on the upper surface of the lower flange 27. The roller is further provided with a radially extending annular shoulder 40 bearing against the outer edge 41 of the flange 27 and operating as a thrust resisting portion that maintains the floor 18 in longitudinal alinement with the tracks 26 on the respective sides 17. The roller 38 is retained on the bushing 37 by means of a plate cap 42 bolted at 43 to the boss 36. The inner surface of the cap 42 generally defines the inner upright side of the roller assembly. It should be understood that an important feature of the present invention is to provide rollers 38 that are considerably smaller than the spacing between the upper and lower flanges 25, 27 and for the inner surface, as defined by the cap 42, to be spacedly offset from the surface of the web 28.

A pair of upright scraper blades or rods 50, 51 is disposed within the spacing between the flanges 25, 27 and is supported on the hanger 30 by a series of vertically spaced and inwardly projecting lugs or fingers 52, 53 permitting relative free vertical movement of the respec-

tive blades 50, 51. The blades 50, 51 are longer than the diameter of the roller 38, but are smaller than the spacing between the flanges 25, 27. Also, inner edges 54, 55 lie relatively closely adjacent, but spacedly from the outer surface of the web 28. The edges 54, 55 are also inwardly in respect to the plate 42. The lugs 52, 53 support the scraper blades 50, 51 in an angular relation in respect to the direction of travel so that as they advance over the surface of the lower flange 27 they will guide material both outwardly and in a trailing direction. Also, the lugs 52, 53 are offset vertically on opposite sides of the respective blades 50, 51 so that material may be passed from the inner side of the blades outwardly. As may be clearly evident, the blades 50, 51 are retained in an area defined on the upper side by the flange 25, on the lower side by the flange 27, on the inner side by the web 28, and on the outer side by the upper portion 35 of the hanger member 30.

In operation the entire supporting assembly operates in the following manner. The roller 38 normally rolls on the surface of the lower flange 27. However, there will always be a tendency for dirt or other material to build up on the flange 27 and unless restricted to raise the roller 38. This, of course, will cause the roller 38 to pack the material on the flange 27. Should the material become sufficiently large in regard to the thickness of its buildup, it will, of course, raise the scraper blades 50, 51. However, the blades 50, 51 being longer than the diameter of the rollers 38 will contact the lower surface of the upper flange 25 prior to the time the buildup of material becomes large enough to interfere with operation of the roller 38. At this point the lower edges of the blades 50, 51 will tend to scrape off the upper layer of the material and consequently the rollers 38 will always be free to rotate and material cannot be wedged between them and either of the respective flanges 25, 27. Similarly should a buildup of material begin to accumulate on the web 28, the buildup can be only of such an extent to contact one or both of the inner edges 54, 55 of the scraper blades 50, 51. Consequently material cannot build up sufficiently to contact the surface of the cap 42 and to force the entire hanger structure to become distorted or for the roller 38 to move off of the lower flange 27.

While only one form of the invention has been shown, it should be recognized that other forms and variations will occur to those skilled in the art. Therefore while the preferred form has been shown in concise and detailed manner for the purpose of clearly, and concisely illustrating the principles of the invention, it is not the intention to limit or narrow the invention beyond the broad concepts set forth in the appended claims.

What is claimed is:

1. In a material scraper bowl having a pair of spaced apart and opposed upright sides, and floor structure extending between the lower edges of the sides and having at least a part thereof adapted to move longitudinally along the edges, the combination therewith of the means supporting the movable floor part for longitudinal movement comprising: a longitudinal guide track rigid with each of the sides adjacent their respective lower edges and including a vertical web interconnecting an upper outwardly extending horizontal flange and a lower outwardly extending horizontal flange, the latter having an outer longitudinal edge spaced from the vertical web; a plurality of vertical hanger members disposed outwardly of the tracks having upper portions opposite the tracks and depending lower portions; means supporting the movable floor part on the depending lower portions; roller members rotatably supported on the upper portions and extending inwardly between the upper and lower flanges, the roller members having diameters substantially less than the spacing between the upper and lower flanges and having inner upright faces spacedly offset from the web

and radial annular shoulders engageable with the edges of the lower flanges; vertical scraper blades in advance of and behind the rollers disposed within the spacing between the flanges and having upper and lower edges and inner upright edges adjacent the flanges and webs respectively, the height of the scraper blades being greater than the diameter of the rollers but less than the distance between the flanges, and the inner edges being offset inwardly in respect to the inner faces of the rollers; and inwardly projecting lug means on the upper portion of the hanger member supporting the blades for free vertical and lateral movement within the confines of a spacing defined on the inner side by the web, on the outer side by the upper portion, and on the upper and lower sides by the upper and lower flanges, the lug means further supporting the scraper blades angularly so that as the floor is moved the scraper blades in advance of the rollers will cause material to be scraped both outwardly and in a trailing direction in respect to the direction of the movement.

2. In a material scraper bowl having a pair of spaced apart and opposed upright sides, and floor structure extending between the lower edges of the sides and having at least a part thereof adapted to move longitudinally along the edges, the combination therewith of the means supporting the movable floor part for longitudinal movement comprising: a longitudinal guide track rigid with each of the sides adjacent their respective lower edges and including a vertical web interconnecting an upper outwardly extending horizontal flange and a lower outwardly extending horizontal flange, the latter having an outer longitudinal edge spaced from the vertical web; a plurality of vertical hanger members disposed outwardly of the tracks having upper portions opposite the tracks and depending lower portions; means supporting the movable floor part on the depending lower portions; roller members rotatably supported on the upper portions and extending inwardly between the upper and lower flanges, the roller members having diameters substantially less than the spacing between the upper and lower flanges and having inner upright faces spacedly offset from the web and radial annular shoulders engageable with the edges of the lower flanges; vertical scraper blades disposed within the spacing between the flanges and having upper and lower edges and inner upright edges adjacent the flanges and webs respectively, the height of the scraper blades being greater than the diameter of the rollers but less than the distance between the flanges and the inner edges being offset inwardly in respect to the inner faces of the rollers; and support means on the upper portion of the hanger member for retaining the scraper blades vertically and permitting free vertical and lateral movement within the confines of a spacing defined on the inner side by the web, on the outer side by the upper portion, and on the upper and lower sides by the upper and lower flanges, the support means further supporting the scraper blades angularly so that as the floor is moved the scraper blades will cause material to be scraped outwardly and longitudinally.

3. In a material scraper bowl having a pair of spaced apart and opposed upright sides, and floor structure extending between the lower edges of the sides and having at least a part thereof adapted to move longitudinally along the edges, the combination therewith of the means supporting the movable floor part for longitudinal movement comprising: a longitudinal guide track rigid with each of the sides adjacent their respective lower edges and including a vertical web interconnecting an upper outwardly extending horizontal flange and a lower outwardly extending horizontal flange, the latter having an outer longitudinal edge spaced from the vertical web; a plurality of vertical hanger members disposed outwardly of the tracks having upper portions opposite the tracks and depending lower portions; means supporting the mov-

5

6

able floor part on the depending lower portions; roller members rotatably supported on the upper portions and extending inwardly between the upper and lower flanges, the roller members having diameters substantially less than the spacing between the upper and lower flanges and having inner upright faces spacedly offset from the web and radial annular shoulders engageable with the edges of the lower flanges; vertical scraper blades disposed within the spacing between the flanges and having upper and lower edges and inner upright edges adjacent the flanges and webs respectively, the height of the scraper blades being greater than the diameter of the rollers but less than the distance between the flanges; and support means on the upper portion of the hanger member for retaining the scraper blades vertically and permitting free movement within the confines of a spacing defined on the inner side by the web, on the outer side by the upper portion, and on the upper and lower sides by the upper and lower flanges, the support means further supporting the scraper blades angularly so that as the floor is moved the scraper blades will cause material to be scraped outwardly and longitudinally.

4. In a material scraper bowl having a pair of spaced apart and opposed upright sides, and floor structure extending between the lower edges of the sides and having at least a part thereof adapted to move longitudinally along the edges, the combination therewith of the means supporting the movable floor part for longitudinal movement comprising: a longitudinal guide track opening to one side and rigid with each of the sides adjacent their respective lower edges and including a vertical web interconnecting upper and lower horizontal flanges the lower flange having a longitudinal edge spaced from the vertical web; a plurality of vertical hanger members offset to the open sides of the tracks having upper portions opposite the tracks and depending lower portions; means supporting the movable floor part on the depending lower portions; roller members rotatably supported on the upper portions and extending in the track between the upper and lower flanges, the roller members having diameters substantially less than the spacing between the upper and lower flanges and having inner upright faces spacedly offset from the web and radial annular shoulders engageable with the edges of the lower flanges; vertical scraper blades longitudinally offset in respect to the rollers disposed within the spacing between the flanges and having upper and lower edges and inner upright edges adjacent the flanges and webs respectively, the height of the scraper blades being greater than the diameter of the rollers, but less than the distance between the flanges and the inner edges being offset inwardly toward the web in respect to the inner faces of the rollers; and means on the upper portion of the hanger member for supporting the blades in free vertical movement within the confines of a spacing defined on the inner side by the web, on the outer side by the upper portion and the upper and lower sides by the upper and lower flanges, the means further supporting the scraper blades angularly in respect to the direction of travel so that as the floor is moved the scraper blades will cause material to be scraped outwardly through the open sides of the tracks.

5. In a material scraper bowl having a pair of spaced apart and opposed upright sides, and floor structure extending between the lower edges of the sides and having at least a part thereof adapted to move longitudinally along the edges, the combination therewith of the means supporting the movable floor part for longitudinal movement comprising: a longitudinal guide track opening to one side and rigid with each of the sides and including vertical interconnected upper and lower horizontal flanges, the lower flange having a longitudinal edge; a plurality of vertical hanger members offset to the open sides of the tracks having upper portions opposite the tracks and

depending lower portions; means supporting the movable floor part on the depending lower portions; roller members rotatably supported on the upper portions and extending in the track between the upper and lower flanges, the roller members having diameters substantially less than the spacing between the upper and lower flanges and radial annular shoulders engageable with the edges of the lower flanges; vertical scraper blades longitudinally offset in respect to the rollers disposed within the spacing between the flanges and having upper and lower edges adjacent the flanges, the height of the scraper blades being greater than the diameter of the rollers, but less than the distance between the flanges; and means on the upper portion of the hanger member for supporting the blades in free vertical movement within the confines of a spacing defined by the upper and lower flanges, the means further supporting the scraper blades angularly in respect to the direction of travel so that as the floor is moved the scraper blades will cause material to be scraped outwardly through the open sides of the tracks.

6. In a material scraper bowl having a pair of spaced apart and opposed upright sides, and floor structure extending between the lower edges of the sides and having at least a part thereof adapted to move longitudinally along the edges, the combination therewith of the means supporting the movable floor part for longitudinal movement comprising: a longitudinal guide track opening to one side and rigid with each of the sides and including vertical interconnected upper and lower horizontal flanges, the lower flange having a longitudinal edge; a plurality of vertical hanger members offset to the open sides of the tracks having upper portions opposite the tracks and depending lower portions; means supporting the movable floor part on the depending lower portions; roller members rotatably supported on the upper portions and extending in the track between the upper and lower flanges, the roller members having diameters substantially less than the spacing between the upper and lower flanges and radial annular shoulders engageable with the edges of the lower flanges; vertical scraper blades longitudinally offset in respect to the rollers disposed within the spacing between the flanges and having upper and lower edges adjacent the flanges, the height of the scraper blades being greater than the diameter of the rollers, but less than the distance between the flanges; and means on the upper portion of the hanger member for supporting the blades in free vertical movement within the confines of a spacing defined by the upper and lower flanges so that as the floor is moved the scraper blades will cause material to be scraped outwardly through the open sides of the tracks.

7. The invention defined in claim 6 in which each roller is positioned between a pair of scraper blades whereby as the floor is extended and retracted the blades will clear the track in advance of the roller.

8. The invention defined in claim 6 in which the means supporting the blades include a series of vertically spaced fingers extending from the upper portions of the hanger members into the open sides of the tracks and adapted to embrace the respective blades on opposite longitudinal sides thereof.

References Cited

UNITED STATES PATENTS

288,918	11/1883	Botsford	16—97
821,630	5/1906	Elliott	16—97
1,185,189	5/1916	Ferris	16—41
2,988,832	6/1961	Hancock et al.	37—129
3,048,933	8/1962	Rasmussen et al.	37—129

ABRAHAM G. STONE, Primary Examiner.

A. E. KOPECKI, Assistant Examiner.