

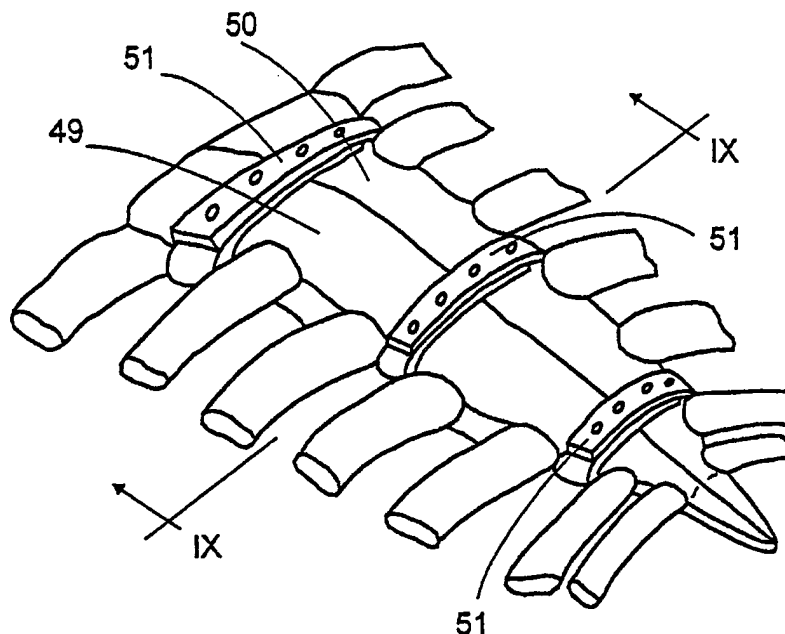

INTERNATIONAL APPLICATION PUBLISHED UNDER THE PATENT COOPERATION TREATY (PCT)

<p>(51) International Patent Classification ⁶ : A61B 17/08</p>	<p>A1</p>	<p>(11) International Publication Number: WO 98/44850</p> <p>(43) International Publication Date: 15 October 1998 (15.10.98)</p>
<p>(21) International Application Number: PCT/IL98/00158</p> <p>(22) International Filing Date: 1 April 1998 (01.04.98)</p> <p>(30) Priority Data: 120636 10 April 1997 (10.04.97) IL</p> <p>(71) Applicant (for all designated States except US): TECHNION RESEARCH AND DEVELOPMENT FOUNDATION LTD. [IL/IL]; Senate House, Technion City, Park Gootwirt, 32000 Haifa (IL).</p> <p>(72) Inventors; and (75) Inventors/Applicants (for US only): AMMAR, Roni [IL/IL]; Tel Manneh 38A, 34366 Haifa (IL). HAR-SHAI, Yaron [IL/IL]; Aharonson Street 7, 34785 Haifa (IL). TORMALA, Pertti [FI/FI]; Tampere University of Technology, Institute of Biomaterials, P.O. Box 589, FIN-33101 Tampere (FI).</p> <p>(74) Agent: REINHOLD COHN AND PARTNERS; P.O. Box 4060, 61040 Tel Aviv (IL).</p>		<p>(81) Designated States: AL, AM, AT, AU, AZ, BA, BB, BG, BR, BY, CA, CH, CN, CU, CZ, DE, DK, EE, ES, FI, GB, GE, GH, GM, GW, HU, ID, IL, IS, JP, KE, KG, KP, KR, KZ, LC, LK, LR, LS, LT, LU, LV, MD, MG, MK, MN, MW, MX, NO, NZ, PL, PT, RO, RU, SD, SE, SG, SI, SK, SL, TJ, TM, TR, TT, UA, UG, US, UZ, VN, YU, ZW, ARIPO patent (GH, GM, KE, LS, MW, SD, SZ, UG, ZW), Eurasian patent (AM, AZ, BY, KG, KZ, MD, RU, TJ, TM), European patent (AT, BE, CH, CY, DE, DK, ES, FI, FR, GB, GR, IE, IT, LU, MC, NL, PT, SE), OAPI patent (BF, BJ, CF, CG, CI, CM, GA, GN, ML, MR, NE, SN, TD, TG).</p> <p>Published <i>With international search report. Before the expiration of the time limit for amending the claims and to be republished in the event of the receipt of amendments.</i></p>

(54) Title: KIT FOR STERNUM FIXATION IN CHEST SURGERY



(57) Abstract

A tool kit for use in the inducement of the reconstitution and healing of the sternum after operation on a patient in the chest region in which during the operation the sternum is cut into two hemisterna. The kit serves for the post-operational approximation and fixation of the hemisterna in a position which enables their spontaneous growing together. The kit includes an approximation tool (1, 24, 35) for the application of a selected force to the hemisterna to bring them into reconstituted configuration, and a set of clamping apparatus (8, 9, 12, 16, 51) for firmly locking the hemisterna in the reconstituted configuration. The clamping apparatus is made of a non-immunogenic polymeric material that is readily degraded in the patient's body to yield degradation products readily absorbed by the patient's body.

FOR THE PURPOSES OF INFORMATION ONLY

Codes used to identify States party to the PCT on the front pages of pamphlets publishing international applications under the PCT.

AL	Albania	ES	Spain	LS	Lesotho	SI	Slovenia
AM	Armenia	FI	Finland	LT	Lithuania	SK	Slovakia
AT	Austria	FR	France	LU	Luxembourg	SN	Senegal
AU	Australia	GA	Gabon	LV	Latvia	SZ	Swaziland
AZ	Azerbaijan	GB	United Kingdom	MC	Monaco	TD	Chad
BA	Bosnia and Herzegovina	GE	Georgia	MD	Republic of Moldova	TG	Togo
BB	Barbados	GH	Ghana	MG	Madagascar	TJ	Tajikistan
BE	Belgium	GN	Guinea	MK	The former Yugoslav Republic of Macedonia	TM	Turkmenistan
BF	Burkina Faso	GR	Greece	ML	Mali	TR	Turkey
BG	Bulgaria	HU	Hungary	MN	Mongolia	TT	Trinidad and Tobago
BJ	Benin	IE	Ireland	MR	Mauritania	UA	Ukraine
BR	Brazil	IL	Israel	MW	Malawi	UG	Uganda
BY	Belarus	IS	Iceland	MX	Mexico	US	United States of America
CA	Canada	IT	Italy	NE	Niger	UZ	Uzbekistan
CF	Central African Republic	JP	Japan	NL	Netherlands	VN	Viet Nam
CG	Congo	KE	Kenya	NO	Norway	YU	Yugoslavia
CH	Switzerland	KG	Kyrgyzstan	NZ	New Zealand	ZW	Zimbabwe
CI	Côte d'Ivoire	KP	Democratic People's Republic of Korea	PL	Poland		
CM	Cameroon	KR	Republic of Korea	PT	Portugal		
CN	China	KZ	Kazakstan	RO	Romania		
CU	Cuba	LC	Saint Lucia	RU	Russian Federation		
CZ	Czech Republic	LI	Liechtenstein	SD	Sudan		
DE	Germany	LK	Sri Lanka	SE	Sweden		
DK	Denmark	LR	Liberia	SG	Singapore		
EE	Estonia						

KIT FOR STERNUM FIXATION IN CHEST SURGERY

FIELD OF THE INVENTION

The present invention concerns surgical means for approximating bone fragments of the sternum and fixing them in a biologically safe manner ultimately facilitating good functional reconstitution
5 of the original structure.

BACKGROUND OF THE INVENTION AND PRIOR ART

Chest surgery such as, for example, open heart surgery requires opening of the chest and rib cage in order to facilitate access to the organ to be
10 operated. The front central part of the rib cage constitutes a longitudinal bone, the sternum, which overlies the heart and secures the ribs. A specific action performed in such surgery is longitudinal sectioning of the sternum into two halves ("*median sternotomy*"). After performing the heart surgery, the chest is closed as a part of a reconstitution operation, in which among other activities
15 the sternum bone halves are brought to union and secured together by mechanical means.

Post operative complications in the healing of the sternum are not uncommon, resulting from several reasons. Especially troublesome is the constant movement associated with the breathing cycle, to which the bone is
20 subjected, which keeps the sternum in a cyclic strain regime often accompanied by unpredicted mechanical stresses. Such strains may eventually cause nonunion or breakage of the bone. Nowadays as recuperating procedures for cardiac therapy have become more common, sternal complications have been increasing likewise. Healing disorders can be
25 expected to occur more commonly in patients suffering from bone disorders such as excessive porosity.

None of the common traditional methods as well as the newer ones pertaining to this specific type of surgery have so far proved to insure adequate degree of sternum healing in such type of operations. A discussion of methods for sternal closure techniques is elaborated by Cheng W. et al. (Biomechanical Study of Sternal Closure Techniques. *Ann Thorac Surg.* 55:737-40, 1993). Although the authors maintain that wire approximation and tensioning is the method of choice, present medical observations indicate this method to be risky with many complications which arise from inadequate fixation of the bones and interference of the artificial insertions in the physiological make up of the body. Hendrickson S.C. *et al.* (Sternal Plating for The Treatment of Sternal Nonunion. *Ann. Thorac Surg.* 62:512-8, 1996), provide evidence for the superior effectivity of tension bands or plates in securing sternal fragments postoperatively. According to such technique, the bands or plates are made out of stainless steel and as such may require special care or even specific surgery for removal. The use of steel bands instead of wire for closure of sternum halves (called also hemisterna) has been shown to provide better results than wire closures also with respect to pain and duration of hospitalization (Soroff H.S. *et al.* Improved Sternal Closure Using Steel Bands: Early Experience With Three-Year Follow-up. *Ann. Thorac Surg.* 61:1172-6, 1996). Green D.T. *et al.* (U.S. 5,339,870) disclose a mechanical device for providing mechanized method and apparatus which utilizes flexible strap for retaining and securing hemisterna. The same authors disclose in a different publication (U.S. 5,355,913) a mechanical system for retaining and securing split tissue for surgical reconstruction. In this patent an additional feature is disclosed according to which a disengaging mechanism in the mechanical driving gear provides a means for applying an upper limit to the force applied.

Generally, the shortcomings of the present practices are a combination of all or a part of the following: infections caused by metal or

plastic parts intentionally left in the bone or surrounding it, cutting effect exerted by tension stitches left intentionally in the body, pain and aesthetic aspects. The consequences of insufficient or superfluous force applied for the approximation and securing together the two hemisterna, may also be
5 detrimental to the healing process.

Plastic materials made out of biologically benign α - hydroxy acids (Pohjonen T. and Tormala, P. In Vitro Hydrolysis of Self-Reinforced Polylactide Composites. 1996. Medical & Biological Engineering & Computing 34 Supplement 1, Part 1.) have been used in the bone fixation in
10 the form of implants (Bostman O.M., Current Concepts Review: Absorbable Implants for the Fixation of Fractures. *J. Bone Joint Surg.* 73- A (1)148- 152, 1991) or degradable sutures (Cutright D.E. *et al.* Fracture Reduction using a Biodegradable Material, Polylactic acid. *J. Oral Surg.* 29: 393-397, 1971), have revealed good potential for tissue repair and specifically bone fixation.
15 The immune response in the body to such material is negligible, although mild, non specific reactions to the plastic do occur (Santavarita S. *et al.* Immune response to polyglycolic Acid Implants. *J. Bone Joint Surg.* [Br] 72- B:597- 600, 1990).

Polydioxanone, which degrades in the body first to glycolic
20 acid is used as a building block for production of bioabsorbable plastic (Bostman O.M., Current Concepts Review: Absorbable Implants for the Fixation of Fractures. 1991. *J. Bone Joint Surg.* 73- A (1)148- 152.). Perkins D.J. *et al.* (Secondary Sternal Repair Following Median Sternotomy using Interosseous absorbable Sutures and Pectoralis Major Myocutaneous
25 Advancement Flaps. *British Journal of Plastic Surgery* 49:214- 219, 1996), used polydioxanone sutures to achieve sternal repair with excellent therapeutic and aesthetic results.

The use of bioabsorbable plastic straps in surgery for joining split tissue was disclosed (Green D.T. *et al.* U.S. 5,355,913) as a possible

alternative building material in the manufacturing of tissue repair devices. The same authors in U.S 5,339, 870 disclosed a device for applying a buckle assembly that secures a strap in a loop around a split tissue such as a split sternum.

5

SUMMARY OF THE INVENTION

It is the object of the present invention to provide for the purpose of inducement of the reconstitution and healing of the sternum after an operation in the chest region in which the sternum is cut longitudinally
10 along a cutting line into two hemisterna having each a cut edge, improved means for the approximation of the hemisterna so as to bring them into a reconstituted configuration at which their cut edges bear on each other, and for the fixation of the hemisterna in such position so as to enable their growing together.

15 The present invention provides for use in the inducement of the reconstitution and healing of the sternum after operation of a patient in the chest region in which operation the sternum is cut into two hemisterna, a tool kit for the approximation and fixation of the hemisterna in a position which enables their spontaneous growing together, which tool kit comprises:

- 20 (i) an approximator tool for the application of a selected force to the hemisterna to bring them into a reconstituted configuration;
and
(ii) a set of clamping means designed for firmly locking the hemisterna in said reconstituted configuration, which clamping
25 means are made of a non-immunogenic polymeric material that is readily degraded in the patient's body to yield degradation products readily absorbed by the patient's body.

A typical type of operation in the chest region in which the tool kit according to the invention is used is open heart surgery.

Preferably, the said approximator tool is fitted with gauge means for measuring the applied force which is selected in accordance with certain characteristics of the patient such as size, weight, age and sex.

In accordance with one embodiment the approximator tool is designed to hold and tighten the clamping means whereby the operations of approximation and clamping are combined.

In accordance with another embodiment of the invention the approximator tool is designed only for bringing together the hemisterna into a reconstituted configuration and the clamping means are applied separately.

In either embodiment, once the clamping means have been applied and tightened, the approximator tool is withdrawn.

The clamping means in a tool kit according to the invention may be flexible, e.g. in form of a band, belt or strap, or rigid with a measure of resilience, e.g. in form of clamps made of a single body or of interlocking parts. The size of the clamping means is so selected that their full decomposition is completed only when the healing process has progressed to an extent that the sternum is no longer spontaneously split along the cutting line.

BRIEF DESCRIPTION OF THE DRAWINGS

For better understanding of the invention, some specific embodiments will now be described with reference to the annexed drawings in which:

Fig. 1 shows one embodiment of an approximator tool according to the invention in the spread state;

Fig. 2 shows the tool of Fig. 1 in the gripping state;

Fig. 3 shows a clamping and fixing device according to the invention in form of a flexible, corrugated strap;

Fig. 4 is a fragmentary elevation of the strap in the tool of Fig. 3, drawn to a larger scale;

Fig. 5 shows in cross section two hemisterna held together by a strap according to Fig. 3;

5 **Fig. 6** shows an approximator tool according to the invention also serving for the application and tightening of a strap of the kind shown in Fig. 3;

Fig. 7 shows another embodiment of an approximator tool according to the invention.

10 **Fig. 8** is a perspective view of hemisterna in a reconstituted sternum configuration held together by three clamps according to the invention;

Fig. 9 is a section along line IX-IX of Fig. 8; and

Fig. 10 is a perspective view of a clamping device according to the invention.

15

DESCRIPTION OF SPECIFIC EMBODIMENTS

Typically, the clamping and fixation means according to the invention are made of polymerized α -hydroxy carboxylic acids such as, for example, polylactic acid, which hydrolyze gradually in the body down to the benign monomer building block, the size of the clamping means being so
20 selected that they are on the one hand not fully degraded before the healing process of the sternum has progressed sufficiently to avoid any spontaneous fissure along the cutting line, and on the other hand they do not stay undissolved in the body for too long a time in order not to elicit a reaction
25 against foreign bodies (Bostman, O., *et al.*, Foreign Body Reactions to Fraction Fixation Implants of Biodegradable Synthetic Polymers, *J. Bone Joint Surg.*, 72B:59206, 1990). Such selection, similar as the selection of the applicable force for bringing together the hemisterna, is a function of various parameters such as the patient's size, weight, age and sex.

Also preferably, there are provided in accordance with the invention empirical data to guide the user to the selection of the applicable force and to the appropriate size of the clamping means in accordance with the said parameters.

5 Turning now to Figs. 1 and 2, there is shown a forceps-type approximator tool 1 with arms 2 and 3 pivoted together at 4 and whose spread is adjustable by means of a screw threaded bolt 5 integral with arm 2 and screwingly engaging a gauge 7 integral with arm 3. Bolt 5 is fitted with an integral knob 6 by which the bolt is turned whereby the spread of arms 2 and
10 3 is increased or decreased, as the case may be.

Near their gripping ends, arms 2 and 3 carry complementary hemi-clamps 8 and 9. The hemi-clamp 8 has two screw-threaded bores 10 and the hemi-clamp 9 has two screw-threaded bores 11. In the gripping state shown in Fig. 2, bores 10 and 11 are in alignment and one aligned pair of
15 bores is engaged by a screw 12. Different combinations between bores 10 and 11 are possible in dependence on the applied gripping force. It is noted, moreover, that the upper flanges of the hemi-clamps 8,9 may each comprise a larger number of screw-threaded bores which can be brought into alignment in various combinations whereby provision is made for the selection of a
20 larger number of degrees of gripping force.

In operation, the approximator device 1 is brought from the spread state of Fig. 1 into the gripping state of Fig. 2, whereby the hemi-clamps 8 and 9 are brought into inter-engagement while embracing the two hemisterna 13 and 14. Once the desired force has been applied and at
25 least one screw-threaded bore 10 of the flange of the hemi-clamp 8 is brought into alignment with at least one of the two screw-threaded bores 11 in the flange of the hemi-clamp 9, a screw 12 is screwed into at least one pair of aligned bores 9,10, following which the approximator device is brought back

into the spread state, free, however, of the hemi-clamps 8 and 9 which remain on the sternum.

The clamping assembly 8,9,12 is made of a degradable material such as a polymerized α -hydroxy carboxylic acid and as the healing process progresses, the clamping assembly is degraded by hydrolysis and eventually disappears altogether.

Turning now to Figs. 3 to 5, there is shown a clamping device 16 according to the invention in the form of a flexible, corrugated strap 17 having a pointed head portion 18 and at the rear a buckle 19. As shown in Fig. 4, the corrugation is ratchet-like and it is easily understood that a suitable tooth in buckle 19 (not shown) is capable of firmly engaging the corrugated strap. The method in which strap 17 holds together two hemisterna 20 and 21 is shown in Fig. 5 and it is seen there that buckle 19 engages the wound and tightened strap with the tip portion 18 and any excess length of the strap 17 having been cut off.

Attention is now directed to Fig. 6 which shows an approximator tool 24 designed for the application of the corrugated strap of Fig. 3. Tool 24 has grips 25 and 26 pivotally connected to each other at 27 and biased into the spread state by a helical spring 28. As shown, grip 25 has an integral head portion 29 having a through going groove 30 accommodating excessive length of strap 17. A double bent, U-shaped leaf spring 31 anchored at one end in grip 26 has a butt end 32 bearing on strap 17 in groove 30 and having means capable of gliding on the ratchet-type corrugations of strap 17 when tool 24 is compressed thereby releasing strap 17, and engaging the strip when grip 25 is released thereby pulling strap 17 upward (with reference to Fig. 6) and tightening it around hemisterna 20,21. Butt end 32 is fitted with a pointer 33 associated with a gauge 34, indicating the cumulative tightening force by which the hemisterna 20,21 are pressed together.

In operation, a loose loop of strap 17 is formed manually by winding strap around the hemisterna 20 and 21 and threading the tip 18 (Fig. 3) through buckle 19 which is then followed by threading the strap into groove 30 of the approximator 24. The strap is now tightened by a succession
5 of compressions of approximator 24 whereby, as explained, strap 17 is pulled and tightened around the hemisterna 20,21, and when the desired force has been applied as shown by the indication appearing opposite pointer 33, the tightening operation is interrupted, the excessive strap 17 is cut off and the approximator 24 is removed, all of which leads to the configuration of Fig. 5.

10 Attention is now directed to Fig. 7 which shows another, scissor-type approximator device according to the invention. As shown, the approximator 35 comprises arms 36 and 37 pivoted at their center regions (the pivot is not seen in Fig. 7). Arm 36 has a foot 38 fitted with a tooth 39 engaging ratchet bar 40 in the manner shown. Arm 37 comprises a bracket 41
15 holding a sleeve 42 forming part of a gauge 43 and comprising a pin 44 cooperating with a smooth end portion 45 of ratchet bar 40. A sensor spring 46 mounted on arm 37 engages end portion 45 of ratchet bar 40.

In operation, the pointed gripping ends 47,48 of the approximator 35 are inserted into the intercostal spaces (i.e. between adjacent
20 ribs) so as to grip the two hemisterna 49 and 50 shown in Fig. 8, which are then brought together by pressing together the arms 36 and 37. During the compression tooth 39 glides on the ratchet of bar 40 and the cumulative force is read on gauge 43. When the desired force is reached compression is interrupted and the approximator is arrested by tooth 39 engaging the ratchet.
25 At this stage a clamp 51 is applied and fixed and the approximator tool 35 is then removed.

The final reconstitution configuration is shown in Figs. 8 and 9, the latter being a section along line IX-IX of the former. As shown, in this particular case, the hemisterna are held together by three clamps 51.

Attention is now directed to Fig. 10 which shows in perspective an embodiment of a solid clamp according to the invention which is made of one single, resilient piece. As shown, the clamp **53** is in form of a double bent solid resilient strap-shaped sheet **54** having upper and medium arms **55** and **56**, the former having four holes such as hole **57** and the latter having two pins **58** fitting tightly into the holes of arm **55**.

Clamps of Fig. 10 can be used in conjunction with a device according to Fig. 7. Once the two hemisterna **49,50** are brought together, clamps **53** are slid into intercostal spaces other than the one gripped by the tool **35**, and arms **55** and **56** are pressed together whereby the pair of pins **58** engage in tight fit any desired pair of adjacent holes in arm **55**.

CLAIMS:

1. For use in the inducement of the reconstitution and healing of the sternum after operation of a patient in the chest region in which operation
5 the sternum is cut into two hemisterna, a tool kit for the approximation and fixation of the hemisterna in a position which enables their spontaneous growing together, which tool kit comprises:
 - (i) an approximator tool for the application of a selected force to the hemisterna to bring them into a reconstituted configuration; and
 - 10 (ii) a set of clamping means designed for firmly locking the hemisterna in said reconstituted configuration, which clamping means are made of a non-immunogenic polymeric material that is readily degraded in the patient's body to yield degradation products readily absorbed by the patient's body.
- 15 2. A tool kit according to Claim 1, wherein said approximator tool is fitted with gauge means for measuring the force applied for approximating the hemisterna into a reconstituted configuration.
3. A tool kit according to Claim 1 or 2, wherein the approximator tool is designed to hold and tighten the clamping means whereby the
20 operations of approximation and clamping are combined.
4. A tool kit according to Claim 1 or 2, wherein the approximator tool is designed only for bringing together the hemisterna into a reconstituted configuration and the clamping means are applied separately.
5. A tool kit according to any one of Claims 1 to 4, wherein said
25 clamping means is a flexible member selected from the group of flexible bands, belts and straps.
6. A tool kit according to Claim 5, wherein said clamping means is corrugated and comprises a buckle for threading across a portion of said

flexible member, which buckle is capable of gripping a part of said flexible member accommodated therein.

7. A tool kit according to Claim 1, comprising an approximator tool having in combination:

5 an assembly of two handles pivoted to each other and biased into a spread state;

groove means for accommodating a length of a flexible corrugated clamping means as defined in Claim 6; and

10 butt means capable of engaging said flexible corrugated clamping means within said groove.

8. A tool kit according to any one of Claims 1 to 4, wherein said clamping means is rigid with a measure of resilience.

9. A tool kit according to Claim 1, comprising a scissors-like approximator with gripping ends.

15 10. A tool kit according to Claim 1, comprising a forceps-like approximator having arms with end portions capable each to hold a solid hemi-clamp.

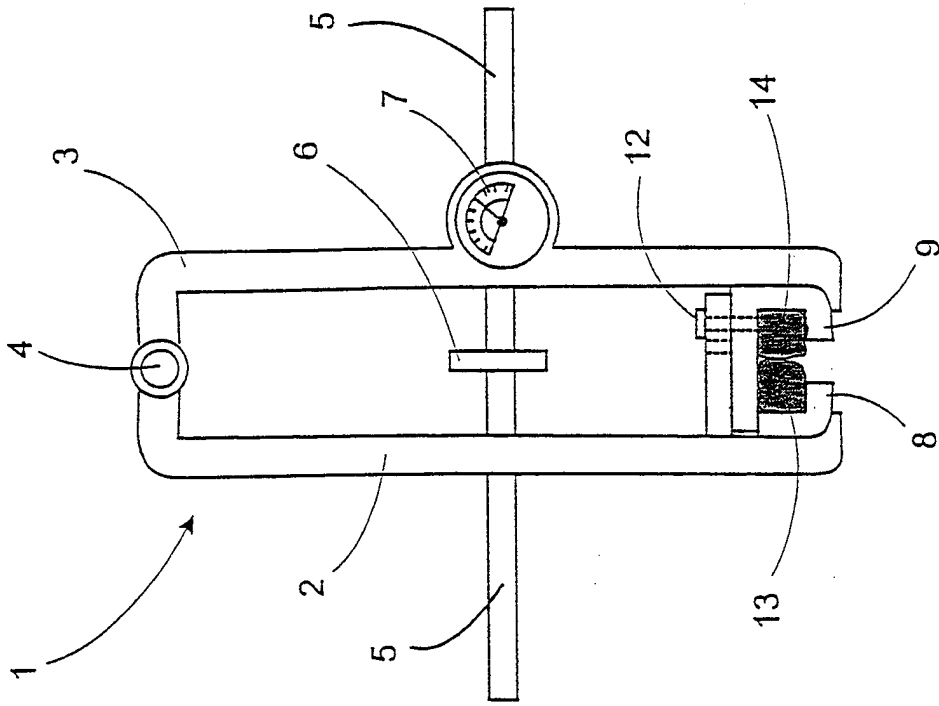

Fig. 2

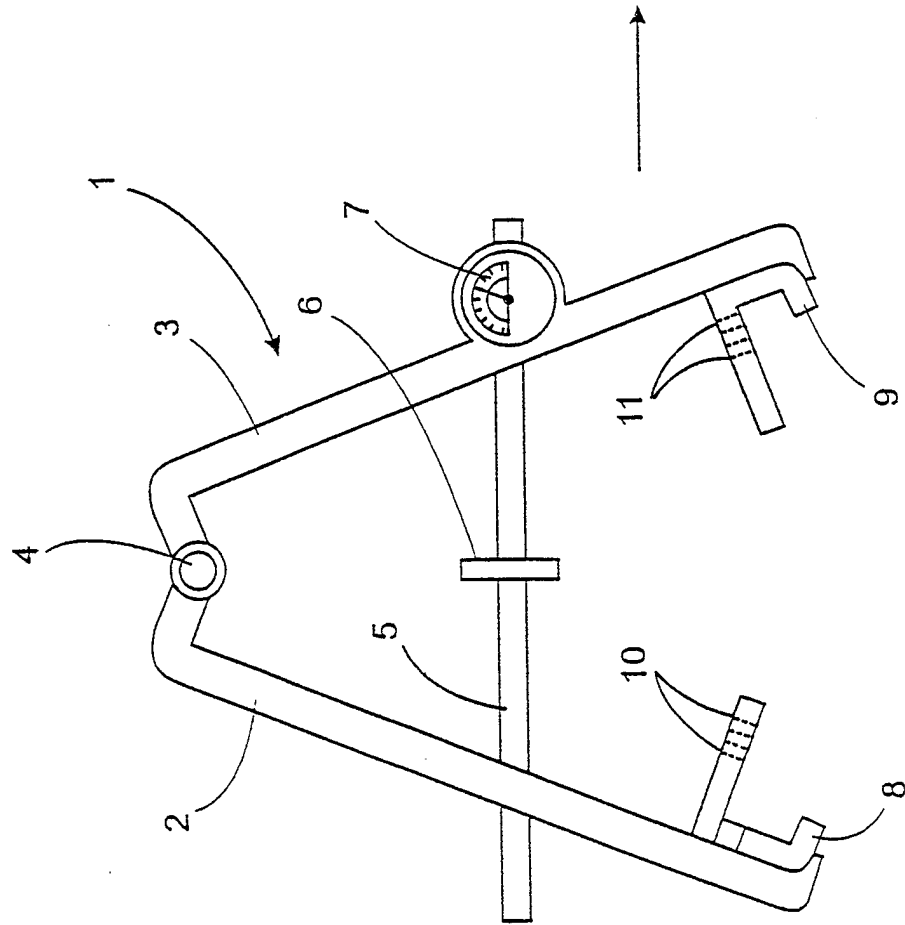

Fig. 1

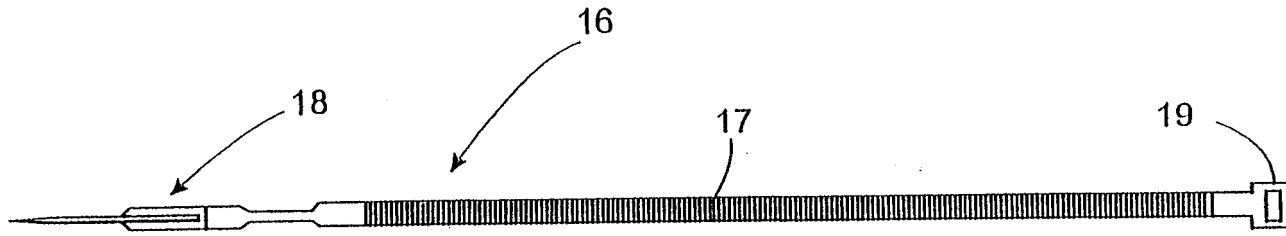

Fig. 3

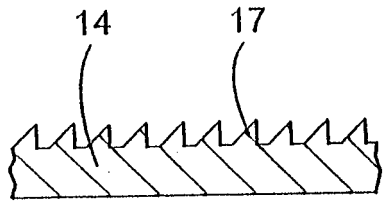

Fig. 4

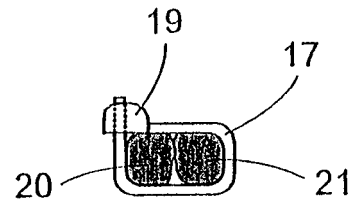

Fig. 5

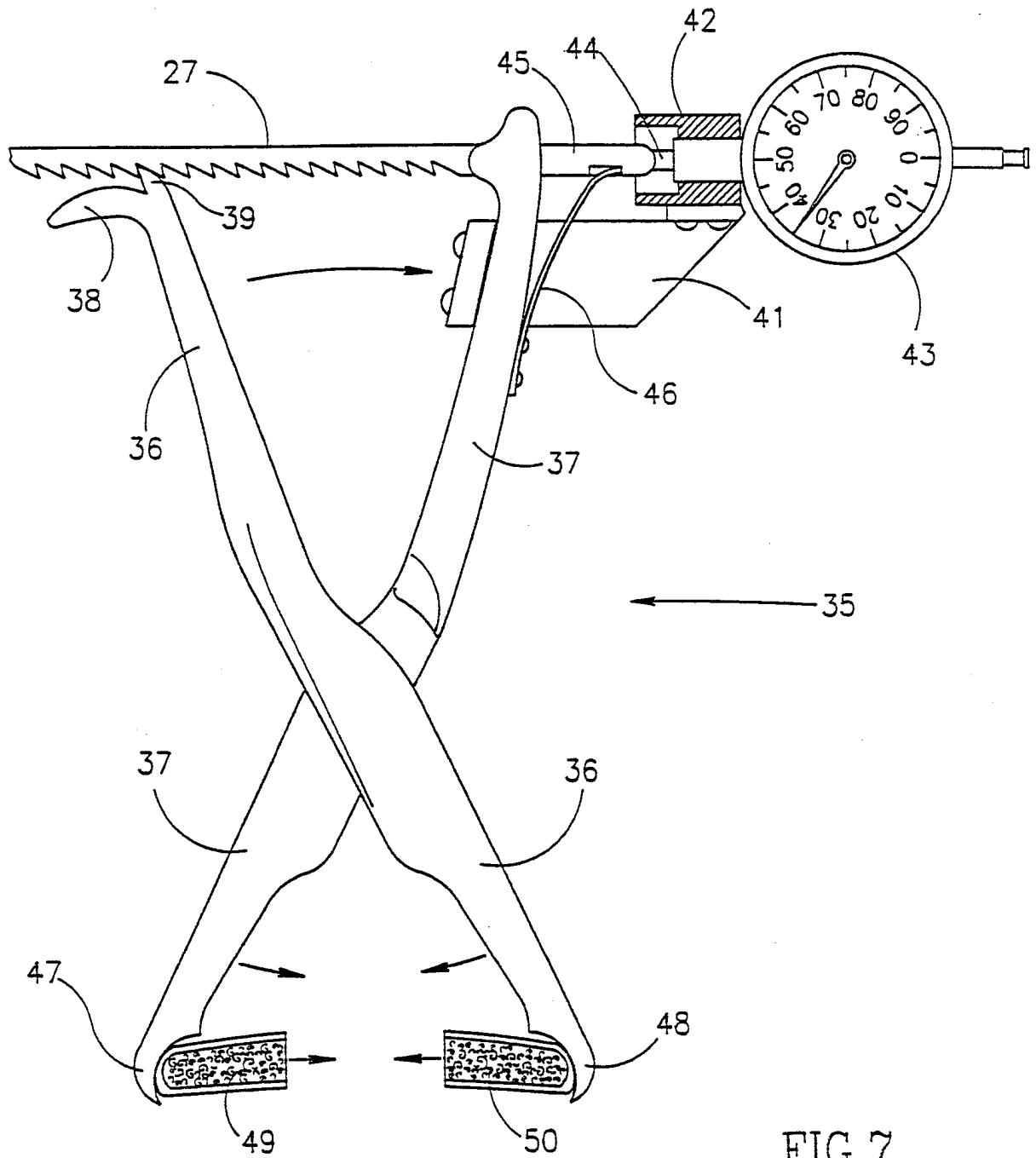

FIG. 7

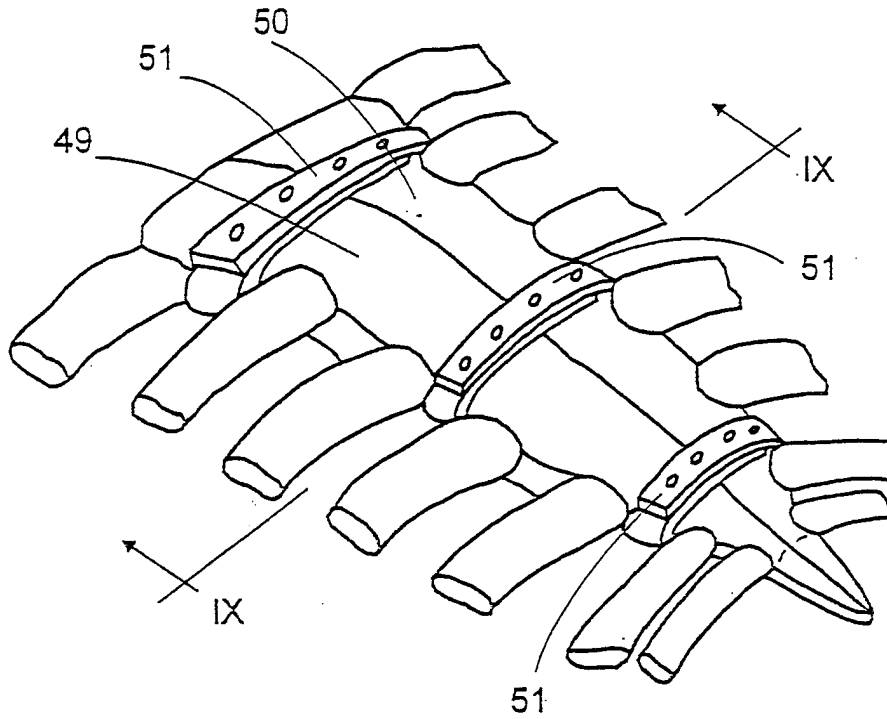

Fig. 8

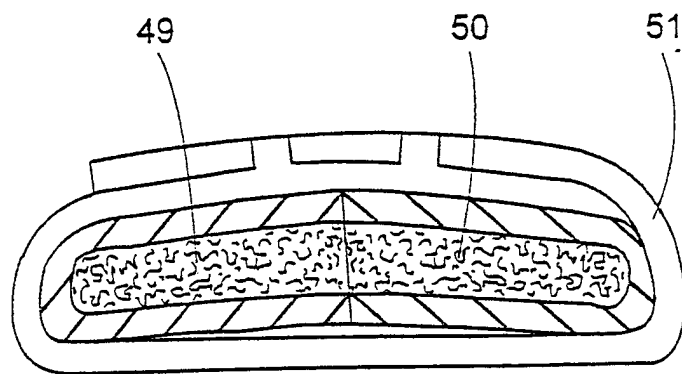

Fig. 9

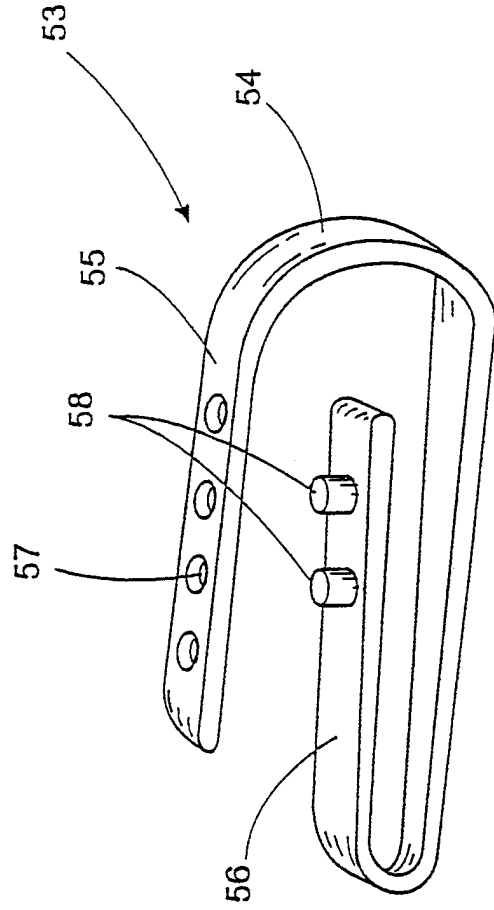

Fig. 10

INTERNATIONAL SEARCH REPORT

International application No.
PCT/IL98/00158

A. CLASSIFICATION OF SUBJECT MATTER
IPC(6) :A61B 17/08
US CL :606/216
According to International Patent Classification (IPC) or to both national classification and IPC

B. FIELDS SEARCHED
Minimum documentation searched (classification system followed by classification symbols)
U.S. : 140/123.5, 123.6; 606/74, 77, 102, 103, 105, 139, 142, 157, 213, 215, 216, 218

Documentation searched other than minimum documentation to the extent that such documents are included in the fields searched

Electronic data base consulted during the international search (name of data base and, where practicable, search terms used)

C. DOCUMENTS CONSIDERED TO BE RELEVANT

Category*	Citation of document, with indication, where appropriate, of the relevant passages	Relevant to claim No.
X	US 5,355,913 A (GREEN et al) 18 October 1994, entire document.	1, 3, 5-8
A	US 5,395,374 A (MILLER et al) 07 March 1995, entire document.	1-10
Y	US 2,291,413 A (SIEBRANDT) 28 July 1942, Figs. 1-4.	1-6, 8-10

Further documents are listed in the continuation of Box C. See patent family annex.

* Special categories of cited documents:	"T" later document published after the international filing date or priority date and not in conflict with the application but cited to understand the principle or theory underlying the invention
"A" document defining the general state of the art which is not considered to be of particular relevance	"X" document of particular relevance; the claimed invention cannot be considered novel or cannot be considered to involve an inventive step when the document is taken alone
"E" earlier document published on or after the international filing date	"Y" document of particular relevance; the claimed invention cannot be considered to involve an inventive step when the document is combined with one or more other such documents, such combination being obvious to a person skilled in the art
"L" document which may throw doubts on priority claim(s) or which is cited to establish the publication date of another citation or other special reason (as specified)	"&" document member of the same patent family
"O" document referring to an oral disclosure, use, exhibition or other means	
"P" document published prior to the international filing date but later than the priority date claimed	

Date of the actual completion of the international search 05 AUGUST 1998	Date of mailing of the international search report 14 SEP 1998
Name and mailing address of the ISA/US Commissioner of Patents and Trademarks Box PCT Washington, D.C. 20231 Facsimile No. (703) 305-3230	Authorized officer <i>David O. Reip</i> for DAVID O. REIP Telephone No. (703) 308-3383